



(12) **United States Design Patent**  
**Holt et al.**

(10) **Patent No.:** **US D911,064 S**  
(45) **Date of Patent:** **\*\* Feb. 23, 2021**

(54) **RAIL WITH END CAP FOR AN ARCHITECTURAL COVERING**

E06B 9/307; E06B 9/322; E06B 9/323;  
E06B 9/324; E06B 9/386; E06B 9/388;  
E06B 9/40; E06B 9/42; E06B 9/521;  
E06B 9/56; E06B 9/60; E06B 9/78

(71) Applicant: **Hunter Douglas Inc.**, Pearl River, NY (US)

See application file for complete search history.

(72) Inventors: **Ronald Holt**, Westminster, CO (US);  
**Stephen Wisecup**, Niwot, CO (US);  
**Arnold Decarlo**, Frederick, CO (US);  
**Fred Bould**, Menlo Park, CA (US);  
**Kwan Hon Anson Cheung**, San Francisco, CA (US)

(56) **References Cited**

U.S. PATENT DOCUMENTS

320,245 A *	6/1885	Hamm	.....	E06B 9/40 160/238
671,755 A *	4/1901	Campbell	.....	A47H 23/01 160/393
738,691 A	9/1903	Michael		
1,436,209 A	11/1922	Stegemeyer		
1,446,837 A	2/1923	Cutright		

(Continued)

(73) Assignee: **Hunter Douglas Inc.**, Pearl River, NY (US)

*Primary Examiner* — Kevin K Rudzinski  
*Assistant Examiner* — Clare Ann Gannon  
(74) *Attorney, Agent, or Firm* — Leason Ellis LLP

(\*\*) Term: **15 Years**

(21) Appl. No.: **29/699,162**

(22) Filed: **Jul. 23, 2019**

**Related U.S. Application Data**

(62) Division of application No. 29/581,048, filed on Oct. 14, 2016, now Pat. No. Des. 858,139.

(51) **LOC (13) Cl.** ..... **06-10**

(52) **U.S. Cl.**

USPC ..... **D6/580**

(58) **Field of Classification Search**

USPC ..... D6/575-581; D8/358; D13/155;  
D25/119, 121, 123, 125; D26/138  
CPC . A47H 1/02; A47H 1/04; A47H 1/144; A47H  
11/06; A47H 2001/042; A47H 2023/003;  
A47H 2023/025; A47H 23/00; A47H  
23/01; A47H 23/02; A47H 3/02; A47H  
3/06; A47H 3/08; A47H 3/10; A47H  
5/00; A47H 5/03; A47H 5/032; A47H  
5/06; A47H 5/08; E06B 9/17; E06B  
2009/2622; E06B 2009/285; E06B 7/28;  
E06B 9/24; E06B 9/26; E06B 9/262;  
E06B 9/30; E06B 9/302; E06B 9/306;

(57) **CLAIM**

We claim the ornamental design for a rail with end cap for an architectural covering, as shown and described.

**DESCRIPTION**

FIG. 1 is an isometric view of a rail with end cap for an architectural covering in accordance with the present design. FIG. 2 is a front elevational view thereof. FIG. 3 is a rear elevational view thereof. FIG. 4 is a right side elevational view thereof. FIG. 5 is a left side elevational view thereof. FIG. 6 is a top plan view thereof; and, FIG. 7 is a bottom plan view thereof. The break lines symbolize breaks in the length of the article in which the claimed design is embodied. The appearance of any portion of the article between the break lines forms no part of the claimed design.

**1 Claim, 5 Drawing Sheets**

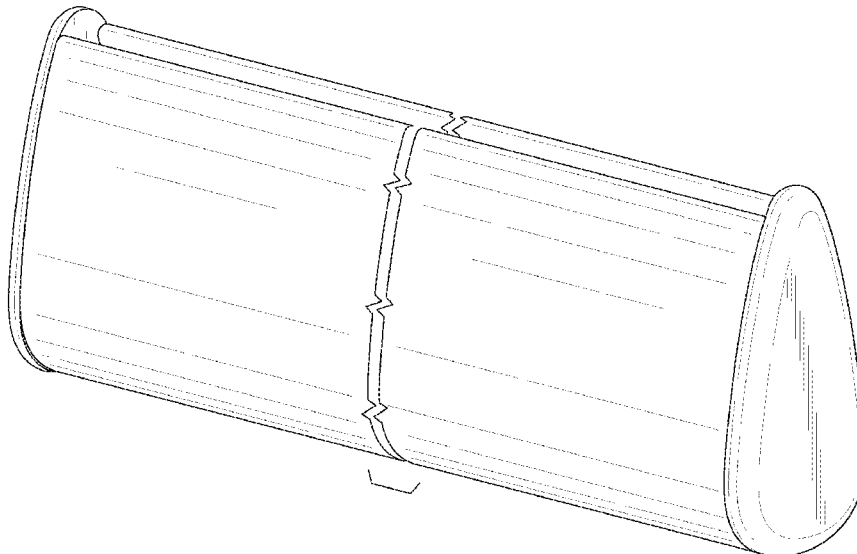

# US D911,064 S

(56)

## References Cited

### U.S. PATENT DOCUMENTS

			D843,131 S *	3/2019	Chou	D6/580
			D858,139 S *	9/2019	Holt	A47H 23/01 D6/580
			2006/0137830 A1	6/2006	Lin	
1,757,017 A	5/1930	Matovitz	2006/0219373 A1	10/2006	McKinney	
1,782,905 A	11/1930	Mohun	2006/0219374 A1	10/2006	McKinney	
2,138,441 A *	11/1938	Bombard	2008/0035281 A1	2/2008	Kirby	
		..... A47H 23/01 160/290.1	2009/0283226 A1 *	11/2009	Cheng	E06B 9/60 160/313
D244,695 S	6/1977	Lindblad	2011/0049071 A1	3/2011	Hart et al.	
4,687,041 A	8/1987	Anderson	2011/0126993 A1 *	6/2011	Allsopp	E04F 10/0633 160/323.1
D306,771 S	3/1990	Gecchelin	2012/0048262 A1	3/2012	Chang	
D328,187 S	7/1992	Saurette	2012/0085503 A1	4/2012	Kotin	
D335,438 S	5/1993	Riegelman	2012/0097346 A1 *	4/2012	Ng	E06B 9/388 160/264
5,647,421 A	7/1997	Hoffmann et al.	2012/0291964 A1	11/2012	Marocco	
D412,635 S	8/1999	Eiling	2012/0291965 A1	11/2012	Marocco	
D442,272 S	5/2001	Gabriele	2014/0311686 A1	10/2014	Yu	
D449,192 S	10/2001	Sheward	2015/0047792 A1	2/2015	Lukosiunas	
D452,403 S	12/2001	Sudano	2015/0292261 A1	10/2015	Chou	
D469,330 S	1/2003	Novoa	2015/0322715 A1 *	11/2015	Chou	E06B 9/24 160/321
6,876,493 B1	4/2005	Lin	2016/0183707 A1 *	6/2016	Fenster	A47H 23/01 160/350
6,978,821 B2	12/2005	Welfonder	2016/0237743 A1 *	8/2016	Holt	E06B 9/262
D522,787 S *	6/2006	Dekker	2016/0273261 A1	9/2016	Pardue	
D530,131 S	10/2006	Chatham	2017/0009519 A1 *	1/2017	Marocco	E06B 9/44
D582,571 S *	12/2008	Bergmann	2017/0081913 A1	3/2017	Chou	
7,458,175 B2	12/2008	Meyer	2017/0175819 A1	6/2017	Ng	
7,510,111 B2	3/2009	Mikkelsen et al.	2017/0292320 A1	10/2017	Chou	
D600,401 S	9/2009	Varrin	2018/0106101 A1	4/2018	Holt	
8,291,962 B2	10/2012	Allsopp et al.	2018/0128045 A1	5/2018	Hunsinger	
D670,946 S	11/2012	Ng	2019/0264499 A1 *	8/2019	McNeill	A47H 23/01
D686,434 S *	7/2013	Marocco	2019/0352963 A1 *	11/2019	Jang	E06B 9/80
D692,685 S *	11/2013	Chou				
9,004,142 B2	4/2015	Marocco				
9,062,493 B2	6/2015	Marocco				
D742,138 S *	11/2015	Chou				D6/580
D770,643 S	11/2016	Shargani				
9,598,896 B1	3/2017	Pichik				
D793,765 S *	8/2017	Chou				D6/580

\* cited by examiner

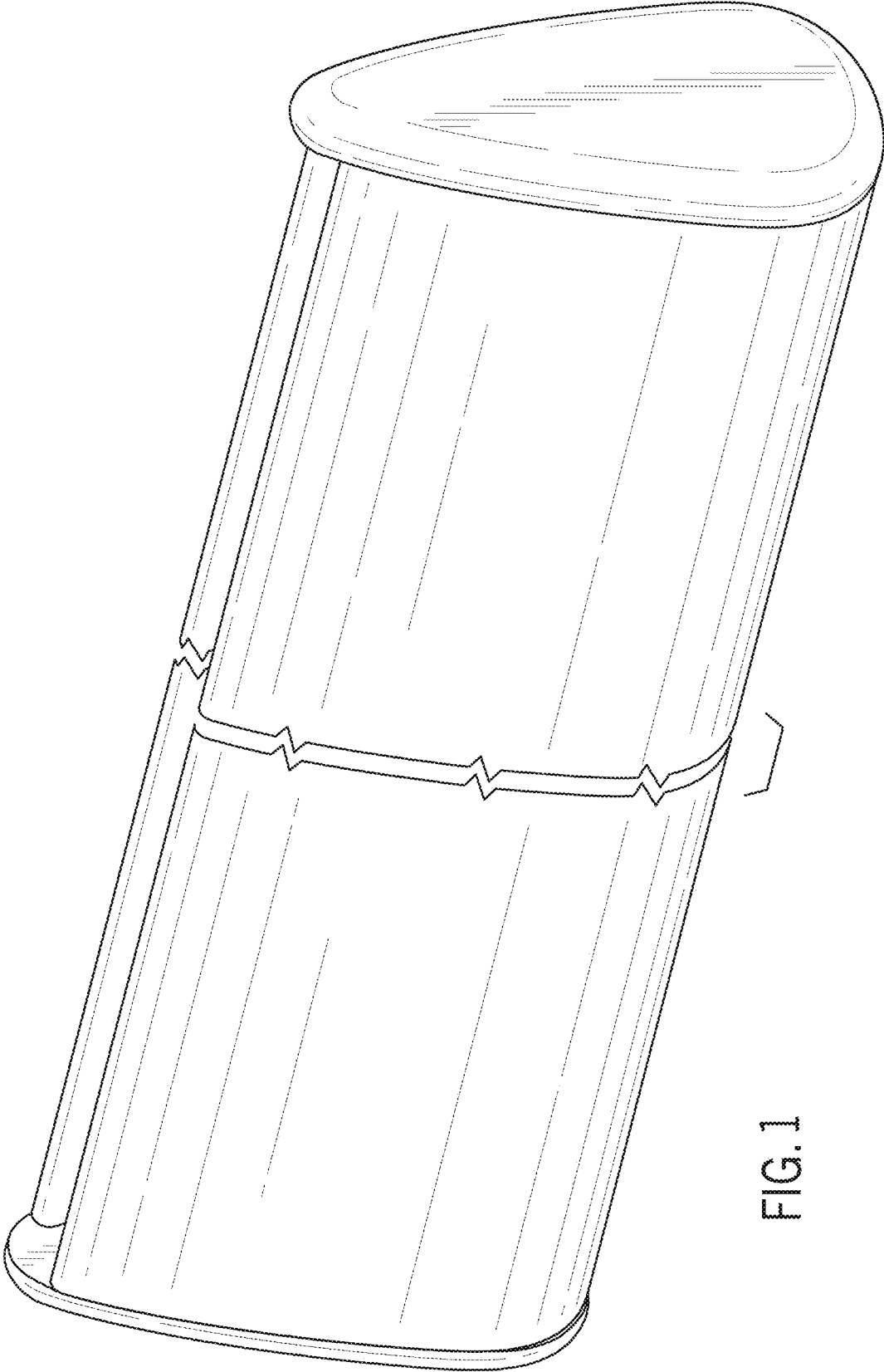

FIG.1

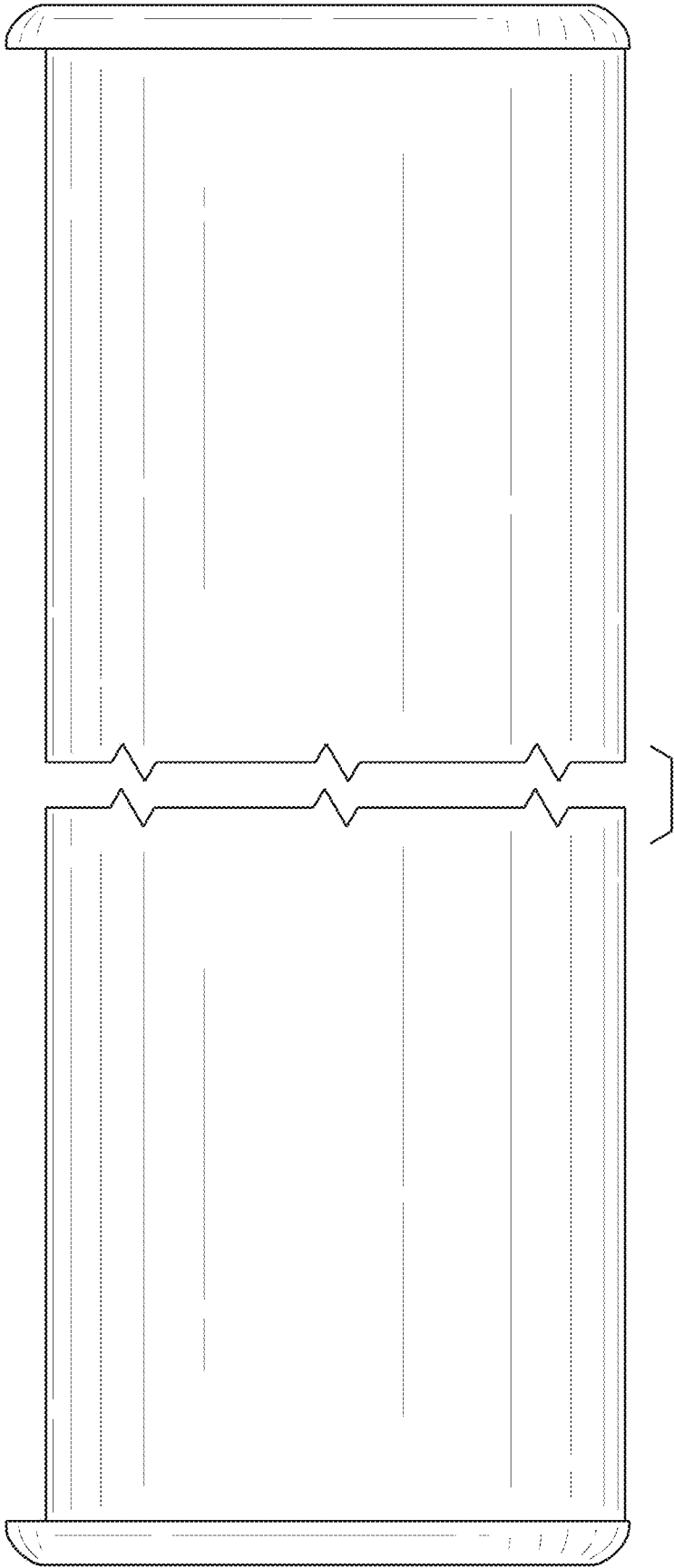

FIG.2

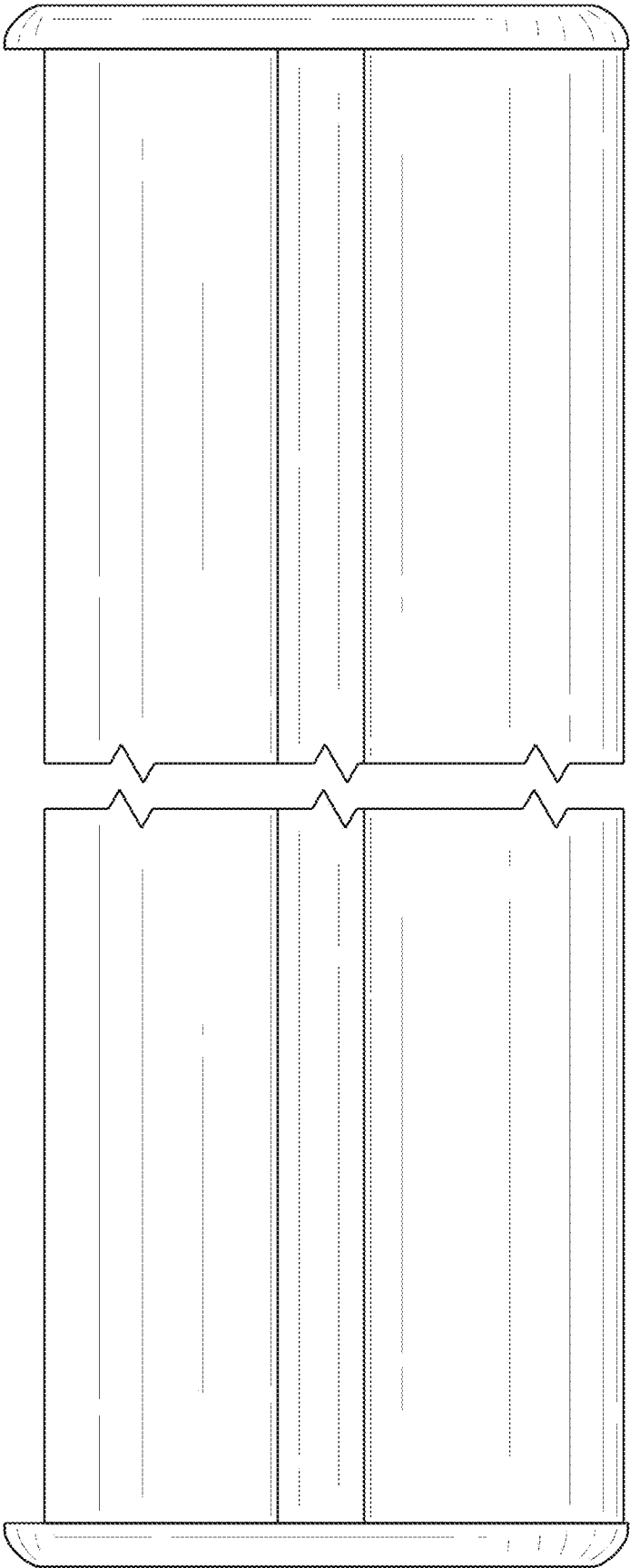

FIG. 3

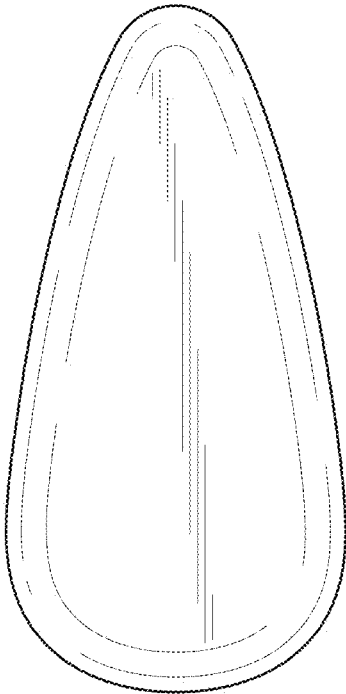

FIG. 4

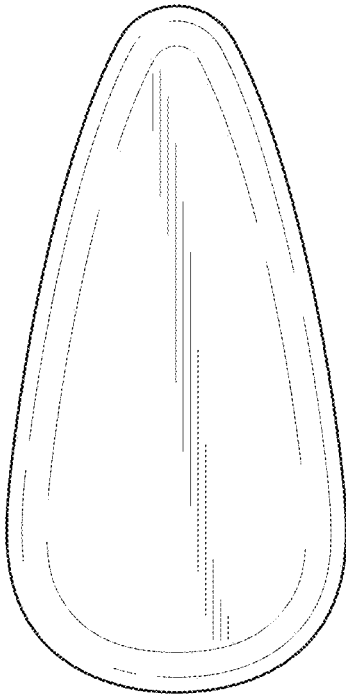

FIG. 5

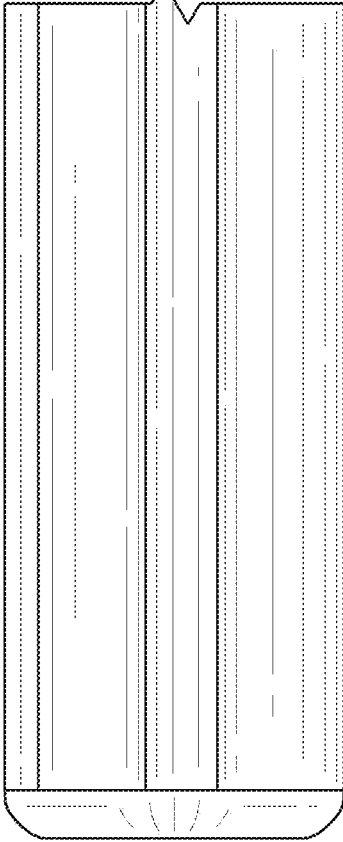
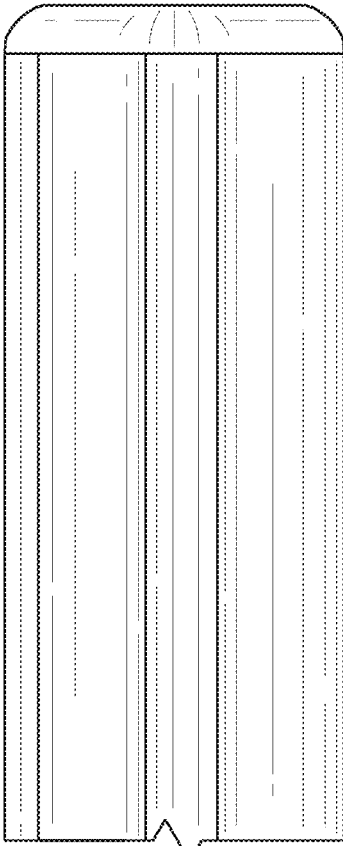

FIG. 6

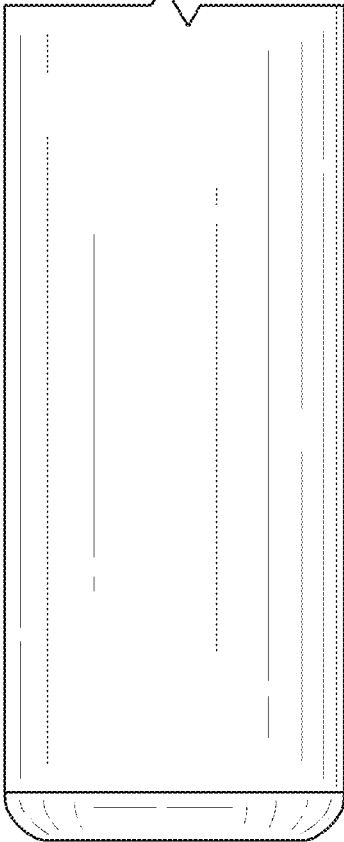
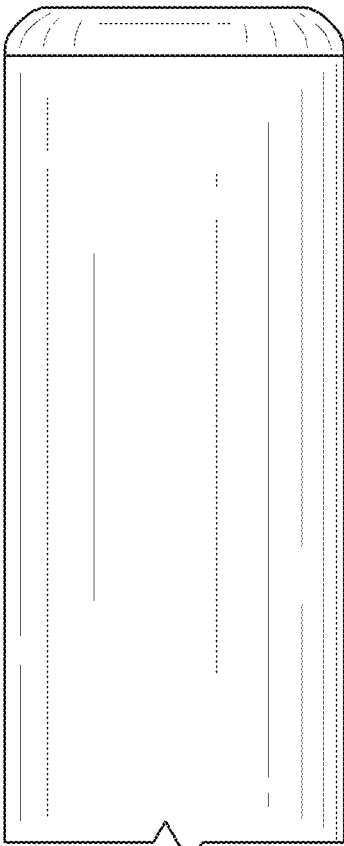

FIG. 7