



US 20040226569A1

(19) **United States**

(12) **Patent Application Publication** (10) **Pub. No.: US 2004/0226569 A1**

Yang et al. (43) **Pub. Date: Nov. 18, 2004**

(54) **FLAVORED CARBON USEFUL AS
FILTERING MATERIAL OF SMOKING
ARTICLE**

(75) Inventors: **Zuyin Yang**, Midlothian, VA (US); **Jose
G. Nepomuceno**, Beaverdam, VA (US);
Barbara G. Taylor, Midlothian, VA
(US)

Correspondence Address:

**BURNS DOANE SWECKER & MATHIS L L P
POST OFFICE BOX 1404
ALEXANDRIA, VA 22313-1404 (US)**

(73) Assignee: **PHILIP MORRIS INCORPORATED**

(21) Appl. No.: **10/868,032**

(22) Filed: **Jun. 16, 2004**

Related U.S. Application Data

(63) Continuation of application No. 10/079,813, filed on
Feb. 22, 2002, now abandoned.

Publication Classification

(51) **Int. Cl.⁷** **A24D 1/04**

(52) **U.S. Cl.** **131/207; 131/202; 131/360**

(57) **ABSTRACT**

Flavored carbon useful as a filtering material of a smoking
article such as a cigarette is made by applying liquid
flavorant to activated carbon particles in a fluidized bed. The
flavored carbon can be used to impart desired taste to
mainstream smoke while removing one or more components
from mainstream smoke.

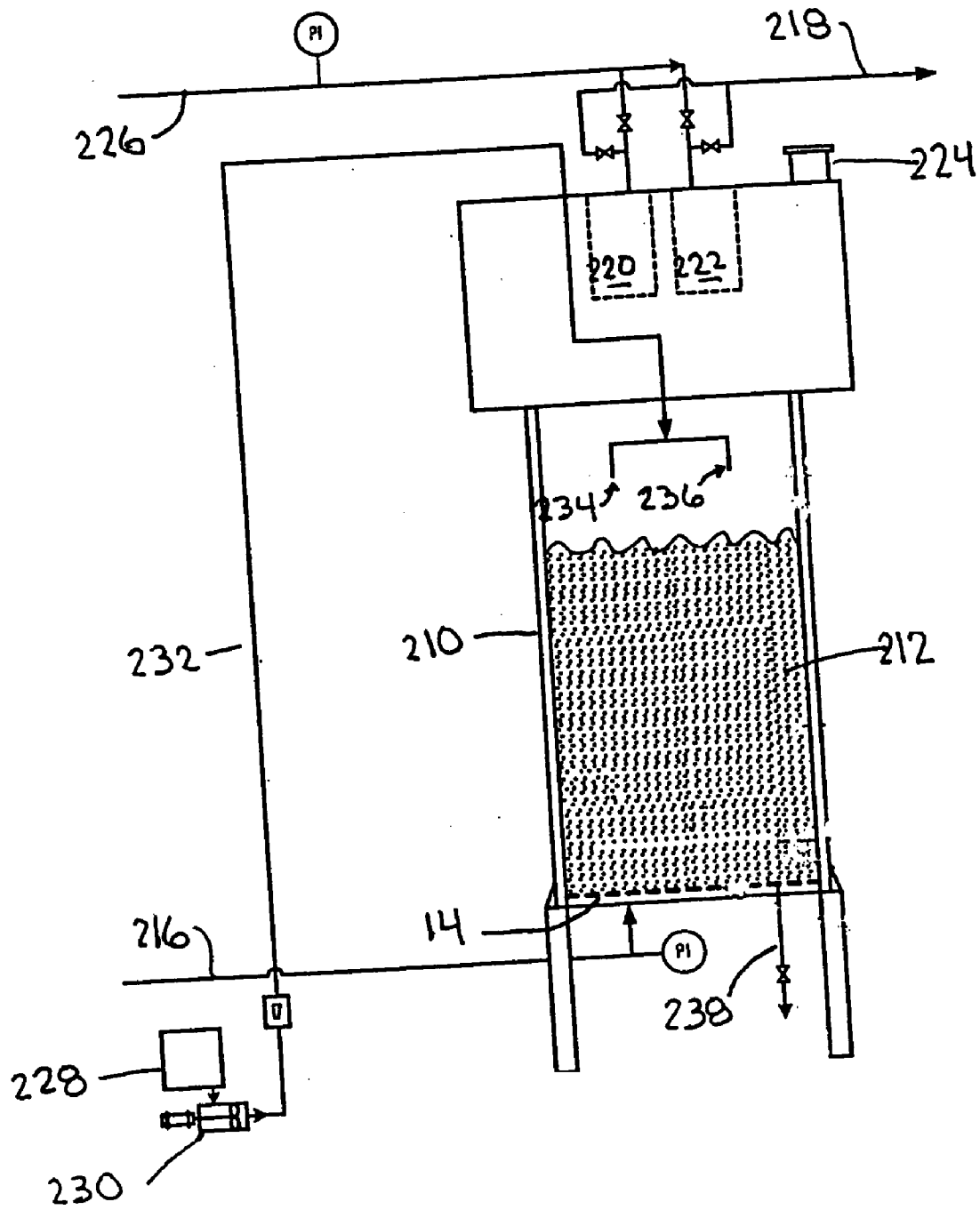

Figure 1

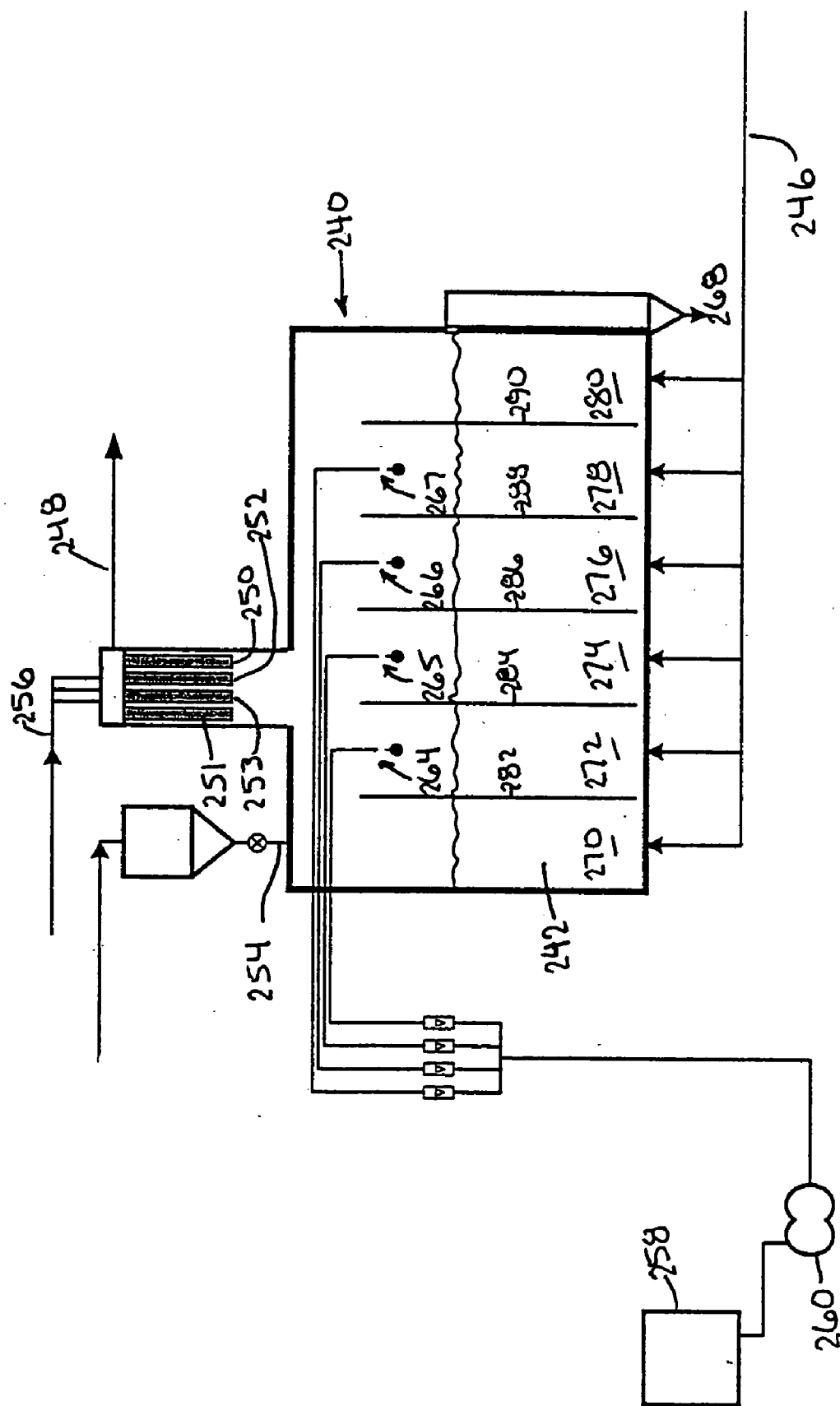

Figure 2

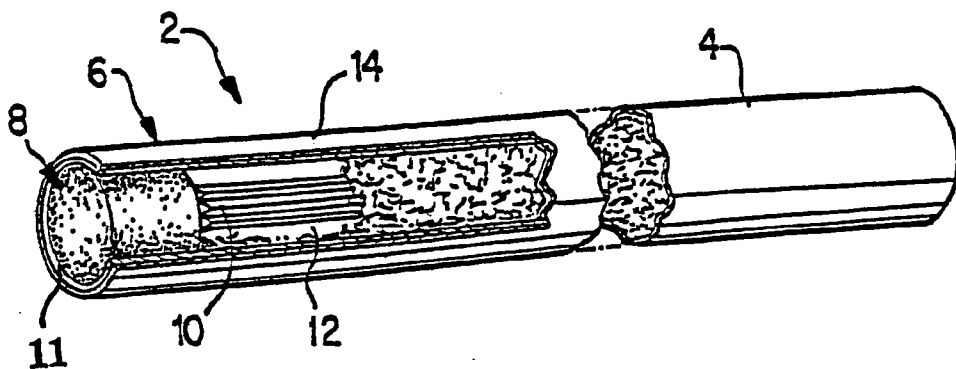

Figure 3

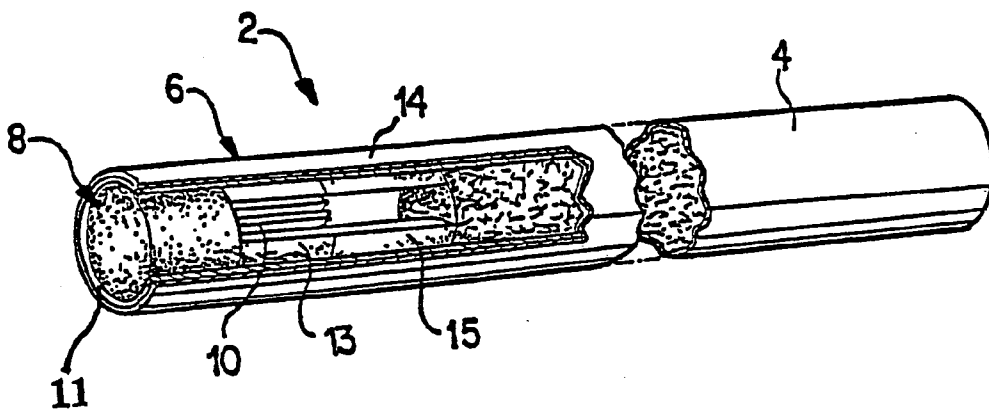

Figure 4

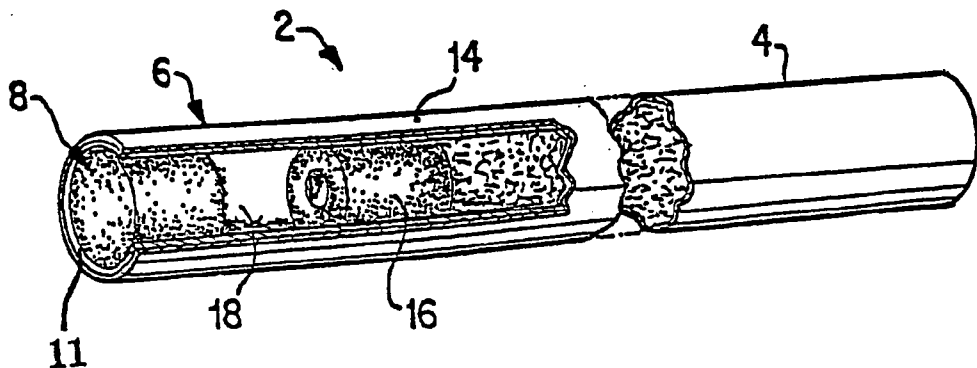

Figure 5

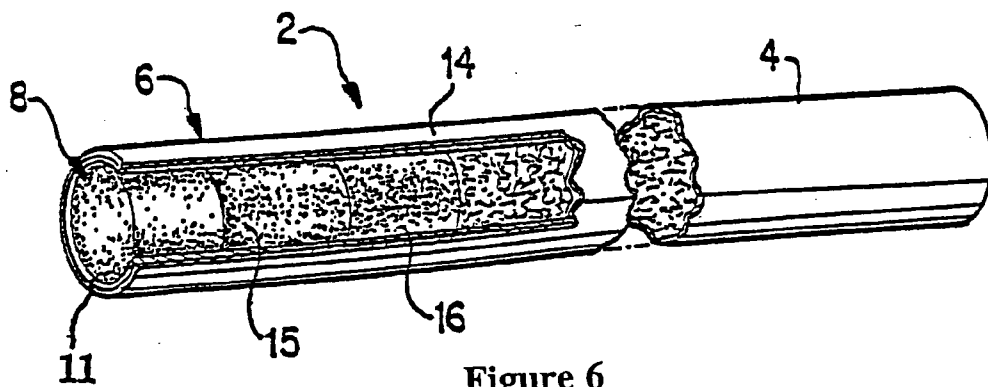

Figure 6

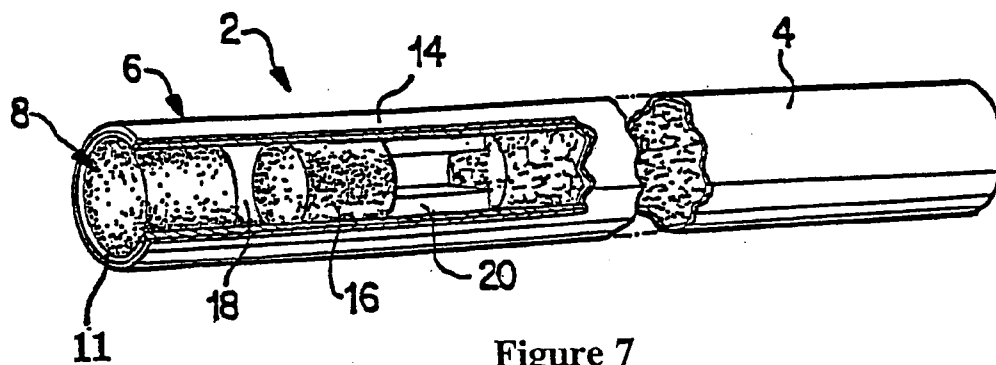

Figure 7

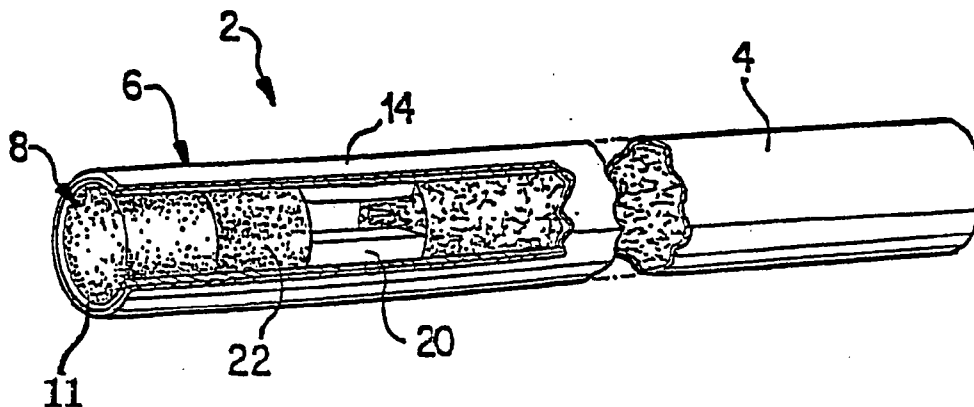

Figure 8

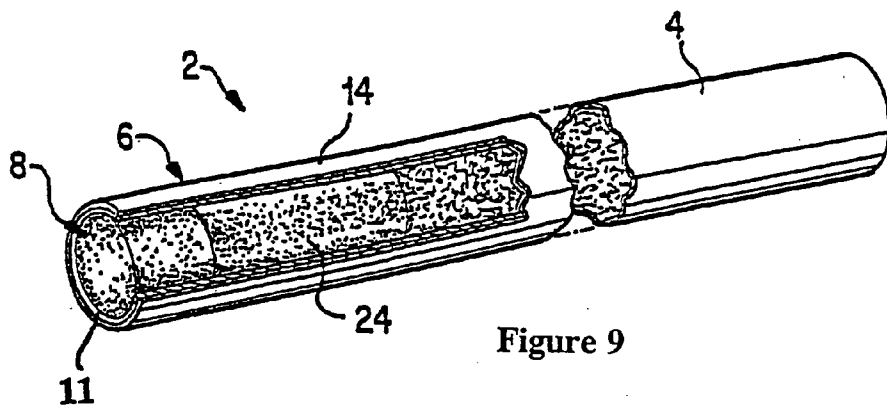

Figure 9

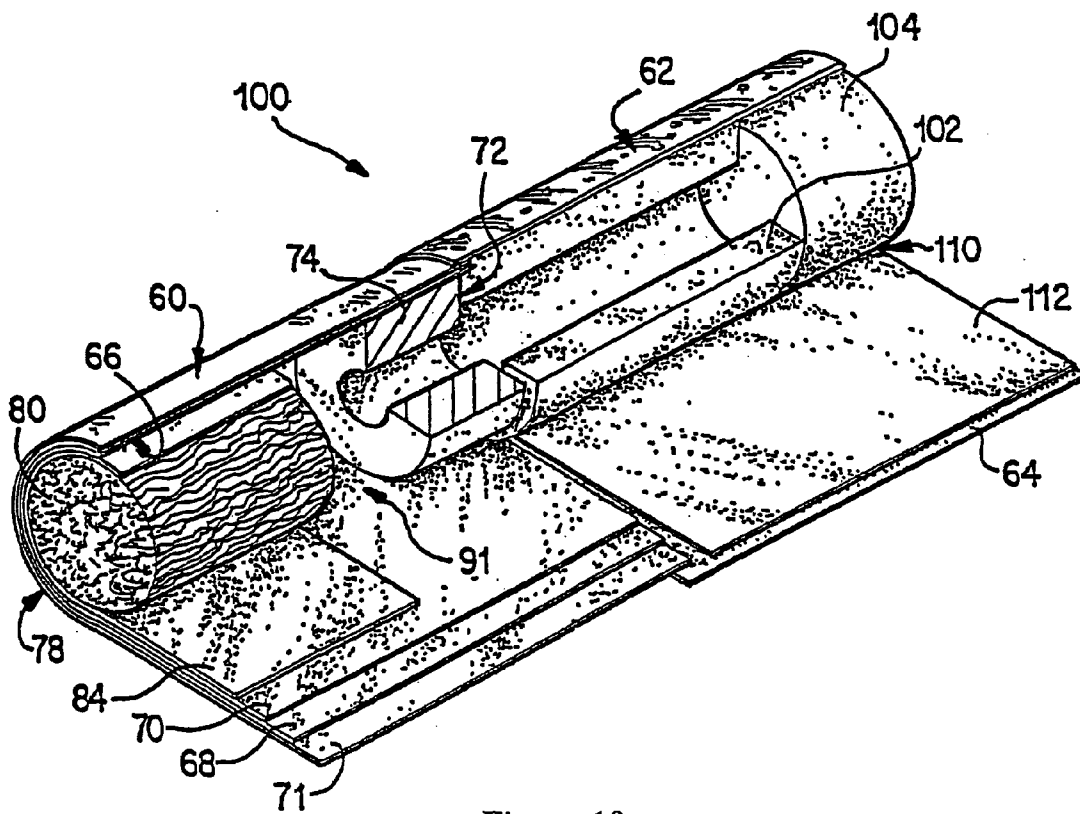

Figure 10

FLAVORED CARBON USEFUL AS FILTERING MATERIAL OF SMOKING ARTICLE

CROSS-REFERENCE TO RELATED APPLICATIONS

[0001] This application is a continuation of U.S. application Ser. No. 10/079,813, filed on Feb. 22, 2002, the entire contents of which are hereby incorporated by reference.

FIELD OF INVENTION

[0002] The invention relates generally to treatment of carbon particles with a flavorant and use of flavored carbon as filtering material in smoking article.

BACKGROUND

[0003] Cigarette filters, incorporating various materials that mechanically, chemically and/or physically remove components of mainstream cigarette smoke have the disadvantage of non-selectively filtering components from mainstream smoke, even those components that contribute to flavor. The result may be a cigarette with an unsatisfactory taste. Efforts to improve taste of cigarettes by incorporating a flavorant in the cigarette have been disclosed in U.S. Pat. Nos. 3,236,244; 3,972,335; 4,281,671; 4,549,875; 4,567,850; 4,662,384; 4,715,390; 4,768,526; 5,012,829; 5,016,654; 5,144,967; 5,356,704; 5,588,446; and 5,598,868.

[0004] U.S. Pat. No. 3,236,244 discloses a cigarette filter in which activated carbon is used to release a flavoring agent during smoking of a cigarette. The '244 patent states that there is no significant release of the adsorbed flavoring agent by volatilization or otherwise during storage and that a filter element containing adsorbed menthol does not evidence the characteristic odor of the flavoring agent. In the sole example in the '244 patent, activated carbon was added to a menthol-ethyl alcohol and water solution, the mixture was agitated at room temperature for two hours, the carbon was separated by filtration and washed three times with water containing 20% alcohol, and the washed carbon was dried for 20 minutes in an oven at 220° F. The carbon product was dispersed in a cellulosic carrier base and formed into paper sheet weighing about 16 grams per square meter.

[0005] U.S. Pat. No. 3,972,335 discloses a cigarette filter containing menthol or other smoke flavoring agent wherein granular activated carbon is impregnated with a pore-modifying agent such as sucrose capable of blocking the most retentive portions of the activated carbon and the less retentive portions of the activated carbon are available for adsorption of the flavoring agent. According to the '335 patent, the activated carbon includes 0.2 to 20, preferably 2 to 10% by weight of the menthol or other smoke flavoring agent. The pore modifying agent is added in amounts of 1 to 40, preferably 5 to 30% by weight of the original weight of the activated carbon, such amounts being less than the maximum amount which could be impregnated in the carbon. The '335 patent states that the pore modifying agent will occupy at least 50% of the pore volume and at least 60% of the surface area. The pore modifying agent materials are preferably organic compositions which are not solvents for menthol or other smoke-flavoring agent. Likewise, the pore modifying agent should not be soluble in the solvent system used to incorporate the menthol or other smoke-flavoring agent when it is later added to the activated carbon. The pore

modifying agent can be sprayed onto the activated carbon or the activated carbon can be immersed in the solution after which the treated carbon is dried at 80 to 110° C. The menthol can be liquefied by heating and sprayed on the carbon, a concentrated solution of menthol in a solvent such as ethanol can be sprayed on the activated carbon.

[0006] U.S. Pat. Nos. 4,163,452 and 4,363,333 disclose the use of porous activated carbon particles as filter material in cigarette filters. The '452 patent discloses that the porous activated carbon is treated with 0.5 to 25% nitroxide and is used in a center section of a triple filter. The '333 patent discloses that the porous activated carbon is treated with 2 to 15% of a C-nitroso compound and the treated carbon is used in the center cavity of a triple filter having 5 mm long filter plugs of cellulose acetate at each end.

[0007] Several modified forms of activated carbon are disclosed in U.S. Pat. Nos. 3,091,550; 3,217,715; 3,652,461; 4,062,368; 5,344,626; 5,496,785; 5,538,929; 5,614,459; 5,705,269; 5,880,061; and 6,117,810. The production of such modified activated carbon typically requires additional process steps, such as coating the activated carbon with solutions, filtration, drying and/or crystallization. U.S. Pat. No. 5,792,720 discloses a method of manufacturing TEDA-impregnated activated carbon in a fluidized bed absorbing tower wherein heated air and TEDA vapor are supplied into a lower portion of the tower.

[0008] U.S. Pat. No. 4,068,389 discloses a distributor plate of a fluidized bed apparatus. Fluidized beds used for drying, granulation, spray coating, agglomeration and the like are disclosed in "Controlling particle size and release properties" by David M. Jones (see Chapter 17 of *Flavor Encapsulation*, ACS Symposium Series 370, 1988, pages 158-176). Despite various developments in adsorbent and filtration materials, an economical technique for production of flavor impregnated carbon would be desirable.

SUMMARY OF THE INVENTION

[0009] In one embodiment, the invention relates to a process for making a flavored carbon which can be used as a flavor release component of a cigarette. The process comprises (i) introducing activated carbon particles into a vessel; (ii) introducing a fluidizing gas into the vessel so as to fluidize the activated carbon particles; and (iii) introducing a liquid flavorant into the vessel while the activated carbon particles are in a fluidized state, the liquid flavorant being applied to the carbon particles via adsorption and/or absorption. Another embodiment of the invention relates to flavored carbon particles produced by this process.

[0010] In another embodiment, the invention relates to a smoking article comprising the flavored carbon particles described above. A preferred smoking article is a cigarette. The flavored carbon particles are dispersed in smoking material and/or located in a filter. Preferably, the smoking article comprises from about 10 mg to about 200 mg of the flavored carbon particles.

[0011] In another embodiment, the invention relates to a cigarette filter comprising the flavored carbon particles described above. Preferably, the cigarette filter comprises from about 10 mg to about 200 mg of the flavored carbon particles. In yet another embodiment, the invention relates to a cut filler composition comprising the flavored carbon particles.

[0012] Preferably, the activated carbon comprises at least about 80% micropores, has an average particle size from about 10 mesh to about 70 mesh, and/or has an average particle size from about 0.2 mm to about 1 mm. The micropore volume of the activated carbon is preferably at least 0.2 cc/g, more preferably 0.2 to 0.4 cc/g.

[0013] An embodiment of the invention also relates to a method of making a cigarette filter, said method comprising: (i) providing flavored carbon particles as described above, and (ii) incorporating the flavored carbon particles into a cigarette filter.

[0014] Another embodiment of the invention relates to a method of making a cigarette, said method comprising: (i) providing a cut filler to a cigarette making machine to form a tobacco rod; (ii) placing a paper wrapper around the tobacco rod; (iii) providing a cigarette filter comprising flavored carbon particles as described above; and (iv) attaching the cigarette filter to the tobacco rod to form the cigarette. In yet another embodiment, the invention relates to a method of making a cigarette, said method comprising: (i) adding flavored carbon particles as described above to a cut filler; (ii) providing the cut filler comprising the surface-modified adsorbent to a cigarette making machine to form a tobacco rod; and (iii) placing a paper wrapper around the tobacco rod to form the cigarette.

BRIEF DESCRIPTION OF THE DRAWINGS

[0015] Various features and advantages of the invention will become apparent from the following detailed description of the preferred embodiments thereof in connection with the accompanying drawings, in which:

[0016] FIG. 1 is a diagram of a batch type fluidizing bed apparatus which can be used to treat carbon particles with a flavoring additive.

[0017] FIG. 2 is a diagram of a continuous type fluidizing bed apparatus which can be used to treat carbon particles with a flavoring additive.

[0018] FIG. 3 is a partially exploded perspective view of a cigarette incorporating one embodiment of the present invention wherein folded paper containing the surface-modified adsorbent is inserted into a hollow portion of a tubular filter element of the cigarette.

[0019] FIG. 4 is partially exploded perspective view of another embodiment of the present invention wherein the surface-modified adsorbent is incorporated in folded paper and inserted into a hollow portion of a first free-flow sleeve of a tubular filter element next to a second free-flow sleeve.

[0020] FIG. 5 is a partially exploded perspective view of another embodiment of the present invention wherein the surface-modified adsorbent is incorporated in a plug-space-plug filter element.

[0021] FIG. 6 is a partially exploded perspective view of another embodiment of the present invention wherein the surface-modified adsorbent is incorporated in a three-piece filter element having three plugs.

[0022] FIG. 7 is a partially exploded perspective view of another embodiment of the present invention wherein the surface-modified adsorbent is incorporated in a four-piece filter element having a plug-space-plug arrangement and a hollow sleeve.

[0023] FIG. 8 is a partially exploded perspective view of another embodiment of the present invention wherein the surface-modified adsorbent is incorporated in a three-part filter element having two plugs and a hollow sleeve.

[0024] FIG. 9 is a partially exploded perspective view of another embodiment of the present invention wherein the surface-modified adsorbent is incorporated in a two-part filter element having two plugs.

[0025] FIG. 10 is a partially exploded perspective view of another embodiment of the present invention wherein the surface-modified adsorbent is incorporated in a filter element which may be used in a smoking article.

DETAILED DESCRIPTION

[0026] The invention provides a process for making flavored carbon particles, wherein a flavorant comprising one or more flavor ingredients is applied to activated carbon particles in a fluidized state. The invention also relates to the flavored carbon particles produced by this process, as well as smoking articles, cigarette filters, and methods which incorporate the flavored carbon particles.

[0027] The flavored carbon particles can be used as a flavor release medium and a filtration agent. In particular, the flavored carbon particles of the invention could be used to release flavor while filtering one or more selected components from mainstream smoke. The term "mainstream" smoke includes the mixture of gases passing down the tobacco rod and issuing through the filter end, i.e. the amount of smoke issuing or drawn from the mouth end of a smoking article during smoking of the smoking article. The mainstream smoke contains smoke that is drawn in through both the lit region of the smoking article, as well as through the paper wrapper.

[0028] Activated carbon is available in various particle form such as granules, beads, powder, or the like and can be made from various sources including bituminous coal, lignite, coconut shells, wood, olive pits, peat, synthetic polymers, petroleum pitch, petroleum coke, and coal tar pitch. Carbon can be activated by steam treatment or chemically, e.g., thermally treating sawdust with phosphoric acid as a catalyst. The activation treatment develops the carbon porosity and activated carbon can be provided with a wide range of pore sizes or the pore sizes can be controlled to provide a desired pore size distribution. For example, U.S. Pat. No. 5,880,061 describes a process to provide coal based carbon with a pore size distribution of at least 0.25 ml/g of pore sizes below 15 angstroms representing at least 40% of the total pore volume of pores up to 300 angstroms and at least 10% of the total pore volume up to 300 angstroms having pore sizes of 100 to 300 angstroms. In general, it is desirable for activated carbon to have a pore volume of at least 0.2 cc/g and a BET specific surface area of at least 100 m²/g, preferably at least 250 m²/g and more preferably at least 500 m²/g, e.g., 1000 to 2000 m²/g. Activated carbon is available in various particle sizes such as 12×20 mesh or 16×35 mesh and U.S. Pat. Nos. 4,163,452 and 4,363,333 describe use of 100 g of activated carbon particles in the cavity of a triple filter for purposes of reducing the level of NO in mainstream smoke. According to the present invention, the flavorant can be applied to commercially available activated carbon or specially prepared activated carbon.

[0029] The flavored carbon particles can be made by the following process, where a fluidizing bed is used to apply a flavorant onto the activated carbon particles. In the process, activated carbon particles are introduced into a vessel. In order to fluidize the particles, a gas such as nitrogen is introduced into the bottom of the vessel. A flavorant such as a conventional or proprietary flavor solution containing one or more flavor ingredients is introduced into the vessel while the particles are in a fluidized state. Preferably, the liquid flavorant is sprayed or dripped onto the fluidized particles while maintaining the particles at ambient temperature, i.e., the process is carried out without heating the particles. Although liquid flavorant is applied to the upper surface of the fluidized bed, the agitation of the carbon particles distributes the flavorant throughout the bed of carbon particles.

[0030] A particularly preferred activated carbon is commercially available from PICA USA, Inc., Truth or Consequences, N. Mex. The activated carbon could also be manufactured by any suitable method known in the art. Such methods include the carbonization of coconut husk, coal, wood, pitch, cellulose fibers, or polymer fibers, for example. Carbonization is usually carried out at high temperatures, i.e. 200-800° C. in an inert atmosphere, followed by activation under reduced conditions. The activated carbon particles produced could be in the form of beads, granules, fragments, powder or fibers.

[0031] In a preferred embodiment, the activated carbon comprises granulated carbon having particles ranging in size from 0.1 mm to about 5 mm. For example, the carbon particles can be carbon pellets having sizes of 0.5 to 5 mm. In a most preferred embodiment, the activated carbon particles range in size from about 0.2 mm to about 1 mm. In terms of Tyler screen mesh size, the carbon particles are preferably from about 6 mesh to about 70 mesh, preferably 10 mesh to about 70 mesh, and more preferably from about 14 to 35 mesh.

[0032] The carbon particles can have any desired pore size distribution such as micropores, mesopores and macropores. The term "microporous" generally refers to such materials having pore sizes of about 20 Å or less while the term "mesoporous" generally refers to such materials with pore sizes of about 20-500 Å. In a preferred embodiment, the proportion of micropores to mesopores will be about 20 to 80% micropores to 80 to 20% mesopores. In a most preferred embodiment, the pores of the activated carbon comprise at least 80% micropores. The relative ratio of micropores, mesopores and macropores can be provided such that selected gaseous components can be removed from the tobacco smoke stream. Thus, the pore sizes and pore distribution can be adjusted accordingly as needed for a certain application.

[0033] The activated carbon can be selected to have a sufficient surface area to preferentially adsorb selected components from cigarette smoke. While surface area is inversely proportional to particle size, when used as cigarette filter material, activated carbon particles of small particle size may pack together too densely to permit mainstream smoke to flow through the filter during smoking. If particle size is too large, there may be insufficient surface area to accomplish the desired degree of filtration. Therefore, such factors can be taken into account in selecting an activated carbon having a particular particle size.

[0034] The flavorant used in making the flavored carbon particles may be adsorbed and/or absorbed by the activated carbon, e.g., the flavorant can be located on the exterior and/or interior surfaces of the activated carbon. However, it is desirable to apply the flavorant in a manner which does not block all of the pores to thereby allow targeted removal of one or more gas components of the tobacco smoke. For example, the flavorant can be applied in a manner which allows the flavored carbon to reduce the content of one or more gaseous components such as 1,3-butadiene, acrolein, isoprene, propionaldehyde, acrylonitrile, benzene, toluene, styrene, acetaldehyde and hydrogen cyanide. For example, the activated carbon particles can be provided with a loading of 0.1 to 20% by weight of the flavorant. A preferred loading is 1 to 5% of the flavorant. Due to volatility of the flavorant, it is preferred to apply the flavorant without heating during the fluidized bed treatment or subsequent thereto.

[0035] In the fluidizing treatment, an inert gas such as nitrogen is used to fluidize the carbon particles. The flow rate of the fluidizing gas will depend on the size of the fluidized bed. In a preferred embodiment, the flow rate is at least 5 ft³/minute, more preferably 10 to 20 ft³/minute. The flow rate of the flavorant onto the carbon particles will depend on the amount of carbon being treated and/or the duration of the fluidized bed treatment. In a preferred embodiment, the flavorant is applied as a liquid at a flow rate of at least 10 g/minute, e.g., 15 to 25 g/minute for a batch of 25 pounds of activated carbon. The flavorant can be dissolved or suspended in a carrier such as propylene glycol, ethyl alcohol, ethanol, water, glycerin or the like, e.g., an aqueous solution containing flavorant and ethanol. After the flavorant is applied to the carbon in the fluidized bed, the fluidizing action can be continued to promote thorough distribution of the flavorant in the fluidized bed. As an example, the flavorant can be applied to the carbon particles for a period of 15 minutes and the fluidizing action can be continued for an additional 5 minutes thereafter. While not wishing to be bound by theory, it is believed that the fluidizing gas is effective in causing the flavorant to be distributed throughout the carbon particles via mass transfer and/or particle collisions.

[0036] According to a preferred embodiment, the flavored carbon according to the invention is prepared in a fluidizing bed apparatus. Any suitable vessel that is capable of maintaining the activated carbon particles in a fluidized state may be used. Such vessels can be designed as batch or continuous processing apparatus. An exemplary batch type fluidized bed arrangement is shown in FIG. 1 and an exemplary continuous type fluidized bed arrangement is shown in FIG. 2. A highly advantageous feature of the fluidized bed technique of applying the flavorant to the carbon is that the carbon can deliver flavor while performing an added function of reducing the content of at least one gaseous component in the tobacco smoke, the at least one gaseous component including 1,3-butadiene, acrolein, isoprene, propionaldehyde, acrylonitrile, benzene, toluene, styrene, acetaldehyde and hydrogen cyanide.

[0037] In the FIG. 1 arrangement, a vessel 200 is loaded with activated carbon 212 and a fluidizing gas flows upwardly through openings in a distribution plate 214. The gas preferably comprises an inert gas such as nitrogen supplied through supply line 216. After passing through the bed of carbon particles, the fluidizing gas is removed from

the vessel through exhaust line 218 after passing through filters 220, 222. The carbon particles can be supplied into the vessel 210 through feed port 224. To clean off accumulated material such as fine carbon particles, a clearing gas such as nitrogen can be blown back through the filters 220, 222 via supply line 226. A series of valves can be used to isolate the exhaust line 218 from the supply line 226 whereby nitrogen is prevented from flowing into supply line 226 when gasses are withdrawn through exhaust line 218. Likewise, the valves can isolate the exhaust line 218 from the blow back gas supplied by supply line 226 during cleaning of the filters 220, 222. The filter cleaning can be conducted during treatment of the carbon, e.g., nitrogen blow back can be carried out periodically while the carbon is in a fluidized state. As an example, if the carbon is treated for 15 minutes, the nitrogen blow back can be carried out in 2 second pulses every 60 seconds during the carbon treatment. Liquid flavorant in tank 228 can be removed by a pump 230 which sends the liquid flavorant through supply line 232 and into the vessel after passing through nozzles 234, 236. The treated carbon can be removed from the vessel through a discharge line 238.

[0038] In the FIG. 2 arrangement, a compartmented vessel 240 is loaded with activated carbon 242 and a fluidizing gas flows upwardly through openings in a distribution plate (not shown). The gas preferably comprises nitrogen supplied through supply line 246. After passing through the bed of carbon particles, the fluidizing gas is removed from the vessel through exhaust line 248 after passing through filters 250, 251, 252, 253. The carbon particles can be supplied into the vessel 240 through feed line 254.

[0039] To clean off accumulated material such as fine carbon particles, a clearing gas such as nitrogen can be blown back through the filters 250, 252 via supply line 256. A series of valves can be used to isolate the exhaust line 248 from the supply line 256 whereby nitrogen is prevented from flowing into supply line 256 when gasses are withdrawn through exhaust line 248. Likewise, the valves can isolate the exhaust line 248 from the blow back gas supplied by supply line 256 during cleaning of the filters 250-253. The filter cleaning can be conducted during treatment of the carbon, e.g., nitrogen blow back can be carried out periodically while the carbon is in a fluidized state. As an example, if the carbon is treated for 15 minutes, the nitrogen blow back can be carried out in 2 second pulses every 60 seconds during the carbon treatment.

[0040] Liquid flavorant in tank 258 can be removed by a pump 260 which sends the liquid flavorant through supply line 262 and into the vessel after passing through nozzles 264, 265, 266, 267. The treated carbon can be removed from the vessel through a discharge line 268. The vessel 240 can have any desired number of compartments, e.g. in the embodiment shown the vessel includes 6 compartments 270, 272, 274, 276, 278, 280 separated by partitions 282, 284, 286, 288, 290. The liquid flavorant can be supplied only to the middle compartments 272, 274, 276, 278 whereby the first compartment 270 can be used as a loading compartment and the last compartment 280 can be used as a discharge compartment.

[0041] Passage of carbon particles from one compartment to the next is achieved by providing one or more openings in the partitions 282, 284, 286, 288, 290. For example, a

single opening can be provided at the bottom of each partition, e.g., a rectangular opening of 1-2 inches by 2-4 inches. To prevent the carbon particles from flowing directly from one compartment to the next, it is advantageous to offset the openings, e.g., the first partition 282 can have an opening near one side of the vessel and the next partition 284 can have an opening near the opposite side of the vessel and so on to provide a tortuous path of travel of the carbon through the vessel.

[0042] The fluidized bed of carbon particles behaves like a liquid with a portion of the fluidized particles being driven upwardly by the fluidizing gas with some of the particles being transferred from the first compartment 270 into the second compartment 272 by flowing through an opening (e.g., 1 by 2 inch opening) between the compartments 270, 272 at the bottom of the partition 282. In like manner, the particles move from compartment to compartment until they reach the discharge compartment. Thus, the particles move from compartment to compartment while in a fluidized state and ultimately are removed from the vessel after a predetermined residence time. The residence time can vary depending on the size of the vessel and number of compartments. In a preferred embodiment, the residence time can range from 5 to 60 minutes, more preferably 10 to 20 minutes.

[0043] The sizes of the compartments of the vessel are preferably the same and the liquid flavorant can be distributed in the middle compartments by 2 or more outlets in each compartment. The liquid flavorant is preferably supplied to each compartment at a flow rate which achieves uniform distribution of the flavorant on the carbon particles. For example, the flavorant can be supplied at a flow rate which results in a liquid drops, spray of liquid, or continuous flow of liquid onto the bed of fluidized particles. If sprayed, it is desirable that the flavorant not be atomized to such an extent that volatile flavoring agent(s) is carried out of the vessel rather than be applied to the carbon particles. While not wishing to be bound by theory, it is believed that uniform distribution of the flavorant is assisted by the fluidizing gas which aids mass transfer of flavorant from particle to particle as the particles travel in vertical and/or horizontal directions in the fluidized bed. A preferred outlet arrangement provides one outlet for distributing flavorant over an area of 20 to 60 in², e.g., about 30 to 40 in² at the upper surface of the fluidized bed.

[0044] The flavorant can be applied to the fluidized particles at any desired temperature. In a preferred embodiment, the bed is not heated and the particles can be at a temperature in the range of 40 to 70° F., preferably 45 to 65° F. Heating of the carbon particles during the treatment is not required because adequate impregnation of the particles with the flavorant can be achieved without heating. In fact, depending on the flavorant composition, heating of the fluidized particles could result in loss of flavorant through evaporation of the flavorant. In a preferred embodiment, substantially all of the flavorant introduced into the vessel is impregnated in the carbon particles. In terms of added weight, the carbon particles can be treated to include 0.1 to 20% of the flavorant, preferably 1 to 5% flavorant. The flavorant preferably masks the taste of the carbon particles and introduces acceptable flavor and taste characteristics when used in a cigarette filter. Further, it is desirable that the treated carbon particles do not have an objectionable odor, i.e., the treated

carbon particles are essentially odorless. However, when incorporated in a cigarette filter, the treated carbon particles preferably release some of the flavorant (through displacement of the molecules) while removing gaseous components of the tobacco smoke stream passing through the filter.

[0045] The flavored carbon particles may be used in a variety of applications, including smoking articles, cut filler compositions and cigarette filters. Thus, in one embodiment, the invention relates to a smoking article comprising flavored carbon particles. The smoking article may be any article containing smokeable material, such as a cigarette, a pipe, a cigar and a non-traditional cigarette. Non-traditional cigarettes include, for example, cigarettes for electrical smoking systems as described in commonly-assigned U.S. Pat. Nos. 6,026,820; 5,988,176; 5,915,387; 5,692,526; 5,692,525; 5,666,976; and 5,499,636. The flavored carbon particles may be located in a filter and/or dispersed in the smoking material itself. Typical smoking articles will include from about 10 mg to about 200 mg of the flavored carbon particles, although the amount needed can also be determined easily by routine experimentation and/or adjusted accordingly.

[0046] The invention further relates to cigarette filters comprising the flavored carbon particles. Any conventional or modified filter may incorporate the flavored carbon particles. In one embodiment, the flavored carbon particles are incorporated into or onto a support such as paper (e.g., tipping paper) that is located along a filter portion of a cigarette. As will be recognized by persons skilled in the art, such paper can be used, for example, as a wrapper or a liner in the filter portion of the cigarette. The flavored carbon particles can also be loaded onto a support such as lightly or tightly folded paper inserted into a hollow portion of the cigarette filter. The support is preferably in the form of a sheet material such as crepe paper, filter paper, or tipping paper. However, other suitable support materials such as organic or inorganic cigarette compatible materials can also be used.

[0047] FIG. 3 illustrates a cigarette 2 having a tobacco rod 4, a filter portion 6, and a mouthpiece filter plug 8. As shown, flavored carbon particles can be loaded onto folded paper 10 inserted into a hollow cavity such as the interior of a free-flow sleeve 12 forming part of the filter portion 6.

[0048] FIG. 4 shows a cigarette 2 having a tobacco rod 4 and a filter portion 6, wherein the folded paper 10 is located in the hollow cavity of a first free-flow sleeve 13 located between the mouthpiece filter 8 and a second free-flow sleeve 15. The paper 10 can be used in forms other than as a folded sheet. For instance, the paper 10 can be deployed as one or more individual strips, a wound roll, etc. In whichever form, a desired amount of flavored carbon particles can be provided in the cigarette filter portion by adjusting the amount of flavored carbon particles coated per unit area of the paper and/or the total area of coated paper employed in the filter (e.g., higher amounts of surface-modified adsorbent can be provided simply by using larger pieces of coated paper). In the cigarettes shown in FIGS. 1 and 2, the tobacco rod 4 and the filter portion 6 are joined together with tipping paper 14. In both cigarettes, the filter portion 6 may be held together by filter overwrap 11.

[0049] The flavored carbon particles can be incorporated into the filter paper in a number of ways. For example, the

flavored carbon particles can be mixed with water to form a slurry. The slurry can then be coated onto pre-formed filter paper and allowed to dry. The filter paper can then be incorporated into the filter portion of a cigarette in the manner shown in FIGS. 3 and 4. Alternatively, the dried paper can be wrapped into a plug shape and inserted into a filter portion of the cigarette. For example, the paper can be wrapped into a plug shape and inserted as a plug into the interior of a free-flow filter element such as a polypropylene or cellulose acetate sleeve. In another arrangement, the paper can comprise an inner liner of such a free-flow filter element.

[0050] Alternatively, the flavored carbon particles are added to the filter paper during the paper-making process. For example, the flavored carbon particles can be mixed with bulk cellulose to form a cellulose pulp mixture. The mixture can be then formed into filter paper according to methods known in the art.

[0051] In another embodiment of the present invention, the flavored carbon particles are incorporated into the fibrous material of the cigarette filter portion itself. Such filter materials include, but are not limited to, fibrous filter materials including paper, cellulose acetate fibers, and polypropylene fibers. This embodiment is illustrated in FIG. 5, which shows a cigarette 2 comprised of a tobacco rod 4 and a filter portion 6 in the form of a plug-space-plug filter having a mouthpiece filter 8, a plug 16, and a space 18. The plug 16 can comprise a tube or solid piece of material such as polypropylene or cellulose acetate fibers. The tobacco rod 4 and the filter portion 6 are joined together with tipping paper 14. The filter portion 6 may include a filter overwrap 11. The filter overwrap 11 containing traditional fibrous filter material and flavored carbon particles can be incorporated in or on the filter overwrap 11 such as by being coated thereon. Alternatively, the flavored carbon particles can be incorporated in the mouthpiece filter 8, in the plug 16, and/or in the space 18. Moreover, the flavored carbon particles can be incorporated in any element of the filter portion of a cigarette. For example, the filter portion may consist only of the mouthpiece filter 8 and the flavored carbon particles can be incorporated in the mouthpiece filter 8 and/or in the tipping paper 14.

[0052] FIG. 6 shows a cigarette 2 comprised of a tobacco rod 4 and filter portion 6. This arrangement is similar to that of FIG. 3 except the space 18 is filled with flavored carbon particles or a plug 15 made of material such as fibrous polypropylene or cellulose acetate containing the flavored carbon particles. As in the previous embodiment, the plug 16 can be hollow or solid and the tobacco rod 4 and filter portion 6 are joined together with tipping paper 14. There is also a filter overwrap 11.

[0053] FIG. 7 shows a cigarette 2 comprised of a tobacco rod 4 and a filter portion 6 wherein the filter portion 6 includes a mouthpiece filter 8, a filter overwrap 11, tipping paper 14 to join the tobacco rod 4 and filter portion 6, a space 18, a plug 16, and a hollow sleeve 20. The flavored carbon particles can be incorporated into one or more elements of the filter portion 6. For instance, the surface-modified adsorbent can be incorporated into the sleeve 20 or the flavored carbon particles can be filled into the space within the sleeve 20. If desired, the plug 16 and sleeve 20 can be made of material such as fibrous polypropylene or cellulose acetate

containing flavored carbon particles. As in the previous embodiment, the plug **16** can be hollow or solid.

[0054] **FIGS. 8 and 9** show further modifications of the filter portion **6**. In **FIG. 6**, cigarette **2** is comprised of a tobacco rod **4** and filter portion **6**. The filter portion **6** includes a mouthpiece filter **8**, a filter overwrap **11**, a plug **22**, and a sleeve **20**, and the flavored carbon particles can be incorporated in one or more of these filter elements. In **FIG. 9**, the filter portion **6** includes a mouthpiece filter **8** and a plug **24**, and the flavored carbon particles can be incorporated in one or more of these filter elements. Like the plug **16**, the plugs **22** and **24** can be solid or hollow. In the cigarettes shown in **FIGS. 6 and 7**, the tobacco rod **4** and filter portion **6** are joined together by tipping paper **14**.

[0055] Various techniques can be used to apply the flavored carbon particles to filter fibers or other substrate supports. For example, the flavored carbon particles can be added to the filter fibers before they are formed into a filter cartridge, e.g., a tip for a cigarette. The flavored carbon particles can be added to the filter fibers, for example, in the form of a dry powder or a slurry by methods known in the art. If the flavored carbon particles are applied in the form of a slurry, the fibers are allowed to dry before they are formed into a filter cartridge.

[0056] In another preferred embodiment, the flavored carbon particles are employed in a hollow portion of a cigarette filter. For example, some cigarette filters have a plug/space/plug configuration in which the plugs comprise a fibrous filter material and the space is simply a void between the two filter plugs. That void can be filled with the flavored carbon particles of the present invention. An example of this embodiment is shown in **FIG. 5**. The flavored carbon particles can be used in granular form or loaded onto a suitable support such as a fiber or thread.

[0057] In another embodiment of the present invention, the flavored carbon particles are employed in a filter portion of a cigarette for use with a smoking device as described in U.S. Pat. No. 5,692,525, the entire content of which is hereby incorporated by reference. **FIG. 10** illustrates one type of construction of a cigarette **100** which can be used with an electrical smoking device. As shown, the cigarette **100** includes a tobacco rod **60** and a filter portion **62** joined by tipping paper **64**. The filter portion **62** preferably contains a tubular free-flow filter element **102** and a mouthpiece filter plug **104**. The free-flow filter element **102** and mouthpiece filter plug **104** may be joined together as a combined plug **110** with plug wrap **112**. The tobacco rod **60** can have various forms incorporating one or more of the following items: an overwrap **71**, another tubular free-flow filter element **74**, a cylindrical tobacco plug **80** preferably wrapped in a plug wrap **84**, a tobacco web **66** comprising a base web **68** and tobacco flavor material **70**, and a void space **91**. The free-flow filter element **74** provides structural definition and support at the tipped end **72** of the tobacco rod **60**. At the free end **78** of the tobacco rod **60**, the tobacco web **66** together with overwrap **71** are wrapped about cylindrical tobacco plug **80**. Various modifications can be made to a filter arrangement for such a cigarette incorporating the flavored carbon particles of the invention.

[0058] In such a cigarette, the flavored carbon particles can be incorporated in various ways such as by being loaded onto paper or other substrate material which is fitted into the

passageway of the tubular free-flow filter element **102** therein. The flavored carbon particles may also be deployed as a liner or a plug in the interior of the tubular free-flow filter element **102**. Alternatively, the flavored carbon particles can be incorporated into the fibrous wall portions of the tubular free-flow filter element **102** itself. For instance, the tubular free-flow filter element or sleeve **102** can be made of suitable materials such as polypropylene or cellulose acetate fibers and the flavored carbon particles can be mixed with such fibers prior to or as part of the sleeve forming process.

[0059] In another embodiment, the flavored carbon particles can be incorporated into the mouthpiece filter plug **104** instead of in the element **102**. However, as in the previously described embodiments, according to the invention, flavored carbon particles may be incorporated into more than one component of a filter portion such as by being incorporated into the mouthpiece filter plug **104** and into the tubular free-flow filter element **102**.

[0060] The filter portion **62** of **FIG. 10** can also be modified to create a void space into which the flavored carbon particles can be inserted.

[0061] As explained above, the flavored carbon particles can be incorporated in various support materials. When the flavored carbon particles are used in filter paper, the particles may have an average particle diameter of 10 to 100 μm , preferably 30 to 80 μm . When the surface-modified adsorbent is used in filter fibers or other mechanical supports, larger particles may be used. Such particles preferably have a mesh size from 10 to 70, and more preferably from 20 to 50 mesh.

[0062] The amount of flavored carbon particles employed in the cigarette filter by way of incorporation on a suitable support such as filter paper and/or filter fibers depends on the amount of constituents in the tobacco smoke and the amount of constituents desired to be removed. As an example, the filter paper and the filter fibers may contain from 10% to 50% by weight of the flavored carbon particles.

[0063] An embodiment of the invention relates to a method of making a cigarette filter, said method comprising: (i) providing flavored carbon particles as described above, and (ii) incorporating the flavored carbon particles into a cigarette filter. Any conventional or modified methods for making a filter may be used to incorporate the flavored carbon particles.

[0064] Another embodiment of the invention relates to a method of making a cigarette, said method comprising: (i) providing a cut filler to a cigarette making machine to form a tobacco rod; (ii) placing a paper wrapper around the tobacco rod; (iii) providing a cigarette filter comprising flavored carbon particles as described above; and (iv) attaching the cigarette filter to the tobacco rod to form the cigarette. In yet another embodiment, the invention relates to a method of making a cigarette, said method comprising: (i) adding flavored carbon particles as described above to a cut filler; (ii) providing the cut filler comprising the flavored carbon particles to a cigarette making machine to form a tobacco rod; and (iii) placing a paper wrapper around the tobacco rod to form the cigarette.

[0065] Examples of suitable types of tobacco materials which may be used include flue-cured, Burley, Maryland or

Oriental tobaccos, the rare or specialty tobaccos, and blends thereof. The tobacco material can be provided in the form of tobacco lamina; processed tobacco materials such as volume expanded or puffed tobacco, processed tobacco stems such as cut-rolled or cut-puffed stems, reconstituted tobacco materials; or blends thereof. The invention may also be practiced with tobacco substitutes.

[0066] In cigarette manufacture, the tobacco is normally employed in the form of cut filler, i.e. in the form of shreds or strands cut into widths ranging from about $\frac{1}{40}$ inch to about $\frac{1}{20}$ inch or even $\frac{1}{40}$ inch. The lengths of the strands range from between about 0.25 inches to about 3.0 inches. The cigarettes may further comprise one or more flavorants or other additives (e.g. burn additives, combustion modifying agents, coloring agents, binders, etc.) known in the art.

[0067] Techniques for cigarette manufacture are known in the art, and may be used to incorporate the surface-modified adsorbent. The resulting cigarettes can be manufactured to any desired specification using standard or modified cigarette making techniques and equipment. The cigarettes of the invention may range from about 50 mm to about 120 mm in length. Generally, a regular cigarette is about 70 mm long, a "King Size" is about 85 mm long, a "Super King Size" is about 100 mm long, and a "Long" is usually about 120 mm in length. The circumference is from about 15 mm to about 30 mm in circumference, and preferably around 25 mm. The packing density is typically between the range of about 100 mg/cm³ to about 300 mg/cm³, and preferably 150 mg/cm³ to about 275 mg/cm³.

[0068] While the invention has been described with reference to preferred embodiments, it is to be understood that variations and modifications may be resorted to as will be apparent to those skilled in the art. Such variations and modifications are to be considered within the purview and scope of the invention as defined by the claims appended hereto.

[0069] All of the above-mentioned references are herein incorporated by reference in their entirety to the same extent as if each individual reference was specifically and individually indicated to be incorporated herein by reference in its entirety.

1. A process for making flavored carbon particles, the process comprising:

- (i) introducing activated carbon particles into a vessel;
- (ii) introducing a fluidizing gas into the vessel so as to fluidize the activated carbon particles; and
- (iii) introducing a liquid flavorant into the vessel while the activated carbon particles are in a fluidized state, the liquid flavorant being absorbed and optionally adsorbed onto the activated carbon particles such that pores of the flavored carbon particles can preferentially remove at least one selected gaseous component from mainstream tobacco smoke.

2. The process of claim 1, wherein the process is carried out in a batch or continuous manner to provide 0.1 to 20% by weight of flavorant on the activated carbon particles.

3. The process of claim 2, wherein the process is carried out in a batch manner without heating the activated carbon particles while in the fluidized state.

4. A process for making flavored carbon particles, the process comprising:

- (i) introducing activated carbon particles into a vessel containing a plurality of compartments;
- (ii) introducing a fluidizing gas into the vessel so as to fluidize the activated carbon particles such that the activated carbon particles pass sequentially through the compartments while in the fluidized state; and
- (iii) introducing a liquid flavorant into the vessel while the activated carbon particles are in a fluidized state and at ambient temperature, the liquid flavorant being dripped onto an upper surface of the fluidized bed of the activated carbon particles in at least two of the compartments such that the liquid flavorant is absorbed and optionally adsorbed onto the activated carbon particles.

5. The process of claim 1, wherein the activated carbon has an average particle size from about 10 mesh to about 70 mesh.

6. The process of claim 1, wherein the activated carbon has an average particle size from about 0.2 mm to about 1 mm.

7. The process of claim 1, wherein the fluidizing gas is nitrogen.

8. The process of claim 1, wherein the vessel includes a gas exhaust conduit separated from the interior of the vessel by a filter, the process including periodic blowback of gas through the filter to clean activated carbon particles from the filter.

9. The process of claim 1, wherein the process is carried out for 10 to 60 minutes.

10. The process of claim 1, further comprising placing the flavored activated carbon particles in a cigarette filter.

11. The process of claim 1, further comprising placing the flavored activated carbon particles in smoking material of a cigarette.

12. The process of claim 10, wherein the activated carbon comprises at least about 80% micropores.

13. The process of claim 10, wherein the flavored carbon has an average particle size from about 10 mesh to about 20 mesh.

14. The process of claim 10, wherein the flavored carbon has an average particle size from about 0.2 mm to about 1 mm.

15. The process of claim 10, wherein the cigarette filter comprises from about 10 mg to about 200 mg of the flavored carbon.

16. A method of making a cigarette filter, the method comprising:

- (i) providing flavored carbon particles produced according to the process of claim 1, and
- (ii) incorporating the flavored carbon particles into a cigarette filter.

17. A method of making a cigarette, said method comprising:

- (i) providing a cut filler to a cigarette making machine to form a tobacco rod;
- (ii) placing a paper wrapper around the tobacco rod;
- (iii) providing a cigarette filter made by the process according to claim 16; and

- (iv) attaching the cigarette filter to the tobacco rod to form the cigarette.
- 18.** The method of claim 17, wherein the cigarette is for an electrical smoking system.
- 19.** The process of claim 1, wherein the activated carbon particles are at a temperature of 40° F. to 70° F. while in the fluidized state such that the liquid flavorant is impregnated into pores of the activated carbon particles without evaporation of the liquid flavorant.
- 20.** The process of claim 19, wherein substantially all of the liquid flavorant introduced into the vessel is impregnated in the carbon particles.
- 21.** The process of claim 4, wherein the activated carbon particles are at a temperature of 40° F. to 70° F. while in the fluidized state such that the liquid flavorant is impregnated into pores of the activated carbon particles without evaporation of the liquid flavorant.
- 22.** The process of claim 21, wherein substantially all of the liquid flavorant introduced into the vessel is impregnated in the carbon particles.
- 23.** The process of claim 1, wherein the at least one selected gaseous component is selected from the group consisting of 1,3-butadiene, acrolein, isoprene, propionaldehyde, acrylonitrile, benzene, toluene, styrene, acetaldehyde and hydrogen cyanide.
- 24.** The process of claim 16, wherein the flavored carbon particles can preferentially remove at least one selected mainstream tobacco smoke gaseous component selected from the group consisting of 1,3-butadiene, acrolein, isoprene, propionaldehyde, acrylonitrile, benzene, toluene, styrene, acetaldehyde and hydrogen cyanide from mainstream tobacco smoke.
- 25.** The process of claim 17, wherein the flavored carbon particles can preferentially remove at least one selected mainstream tobacco smoke gaseous component selected from the group consisting of 1,3-butadiene, acrolein, isoprene, propionaldehyde, acrylonitrile, benzene, toluene, styrene, acetaldehyde and hydrogen cyanide from mainstream tobacco smoke.
- 26.** The process of claim 4, wherein the flavored carbon particles have a loading of 0.1 to 20% by weight of the flavorant.
- 27.** The process of claim 26, wherein the flavored carbon particles have a loading of 1 to 5% by weight of the flavorant.
- 28.** The process of claim 1, wherein the flavored carbon particles have a loading of 1 to 5% by weight of the flavorant.
- 29.** The process of claim 1, wherein the liquid flavorant is applied onto the activated carbon particles at a flow rate of at least 10 g/min.
- 30.** The process of claim 1, wherein the liquid flavorant is applied onto the activated carbon particles at a flow rate of 15 to 25 g/min.
- 31.** The process of claim 1, wherein the liquid flavorant is dissolved in a carrier selected from the group consisting of propylene glycol, ethyl alcohol, water and glycerin.
- 32.** The process of claim 4, wherein the liquid flavorant is dissolved in a carrier selected from the group consisting of propylene glycol, ethyl alcohol, water and glycerin.
- 33.** The process of claim 1, wherein the fluidizing of the activated carbon particles by the fluidizing gas is continued after the liquid flavorant has been applied to the activated carbon particles to promote distribution of the flavorant in the fluidized bed.
- 34.** The process of claim 4, wherein the fluidizing of the activated carbon particles by the fluidizing gas is continued after the liquid flavorant has been applied to the activated carbon particles to promote distribution of the flavorant in the fluidized bed.
- 35.** The process of claim 4, wherein the compartments are separated by partitions which include at least one opening, the openings in adjacent partitions being offset from each other to prevent the activated carbon particles from flowing directly from one compartment to the next compartment.
- 36.** The process of claim 4, wherein the residence time of the activated carbon particles in the compartments is 5 to 60 minutes.

* * * * *