

[54] APPARATUS FOR INSTALLING PULL LINES IN CONDUITS

[72] Inventors: Howard G. Ruddick; Kenneth H. Long, both of Charlotte, N.C.

[73] Assignee: Jet Line Products, Inc., Matthews, N.C.

[22] Filed: Jan. 14, 1971

[21] Appl. No.: 106,486

[52] U.S. Cl.....254/134.4

[51] Int. Cl.....E21c 29/16

[58] Field of Search.....254/134.4

[56] References Cited

UNITED STATES PATENTS

3,301,531	1/1967	Corsiglia.....	254/134.4
3,091,433	5/1963	Riley	254/134.4
3,549,127	12/1970	Niemann.....	254/134.3 FT

Primary Examiner—Robert C. Riordon
Assistant Examiner—David R. Melton
Attorney—Parrott, Bell, Seltzer, Park & Gibson

[57] ABSTRACT

An apparatus for selectively passing either a cordage pull line or ribbon-like tape pull line secured to a carrier plug through a conduit in response to a fluid pressure differential therein. The apparatus comprises a tubular conduit adapter having a wall defining a passageway for transmitting a fluid pressure therethrough, with one end of the adapter being positionable at the entrance end of the conduit and the other end of the adapter being attachable to a source of fluid pressure. A pull line entrance extends through the wall of the adapter for selective introduction into the passageway of either the cordage or tape pull line without undue loss of fluid therethrough, and comprises a first opening closely conforming to the cross-sectional configuration of the cordage pull line, and a second opening closely conforming to the cross-sectional configuration of the tape pull line. In one disclosed embodiment, the two openings are spaced, and provision is made for selectively covering either one or both of the openings. In a second embodiment, the two openings have portions thereof coinciding such that the total area of the two openings is less than the sum of their individual areas. The second embodiment also includes a cover hingedly mounted adjacent the two openings to selectively close the same.

12 Claims, 18 Drawing Figures

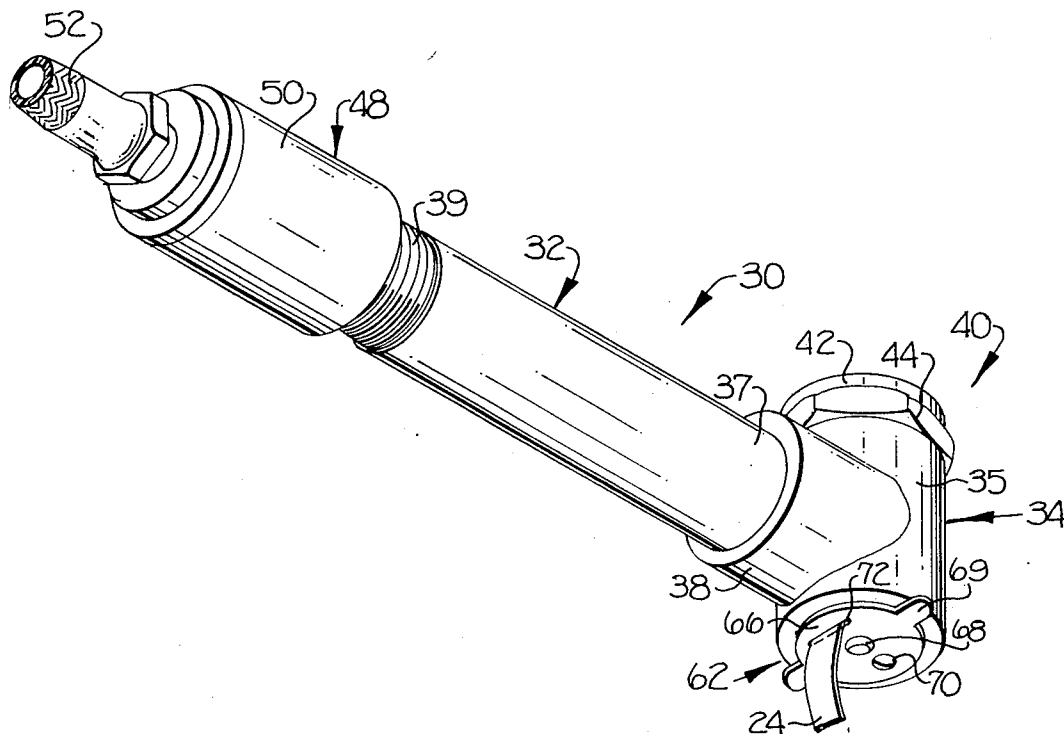

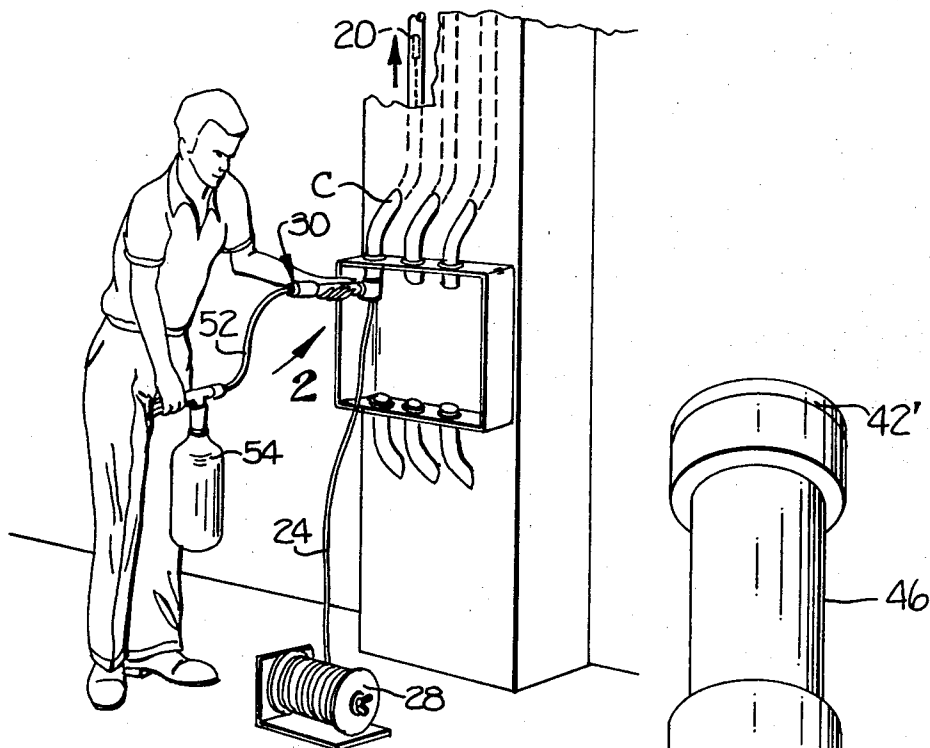

FIG-1

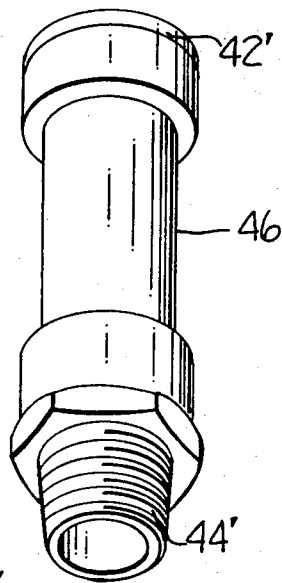

FIG-3

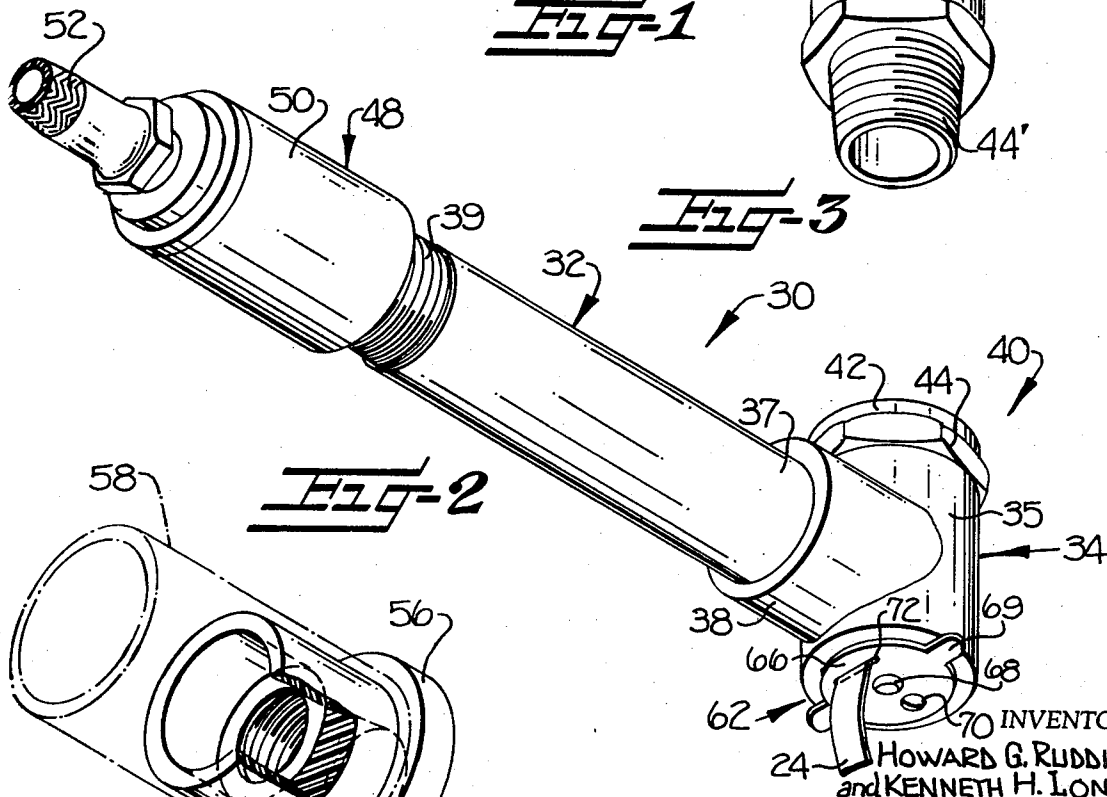

FIG-2

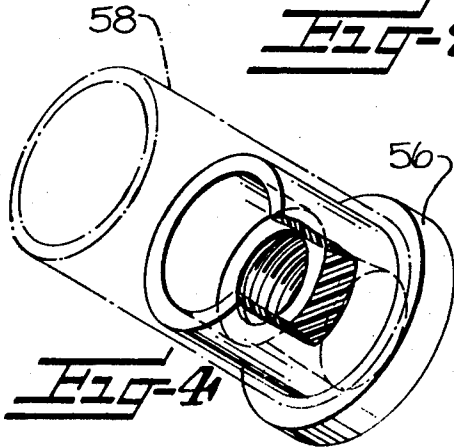
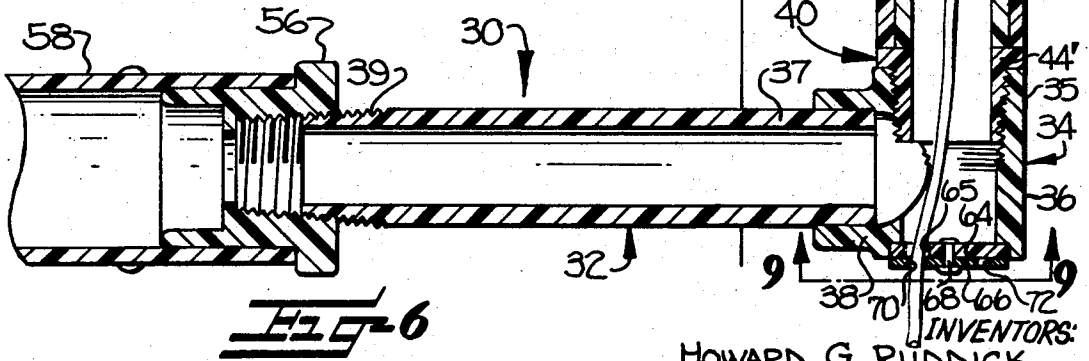
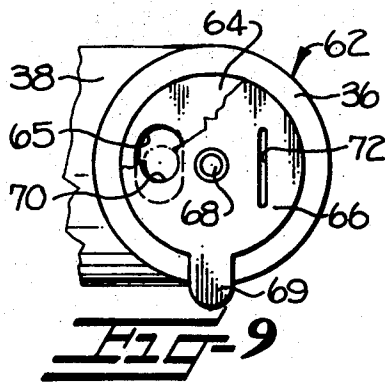
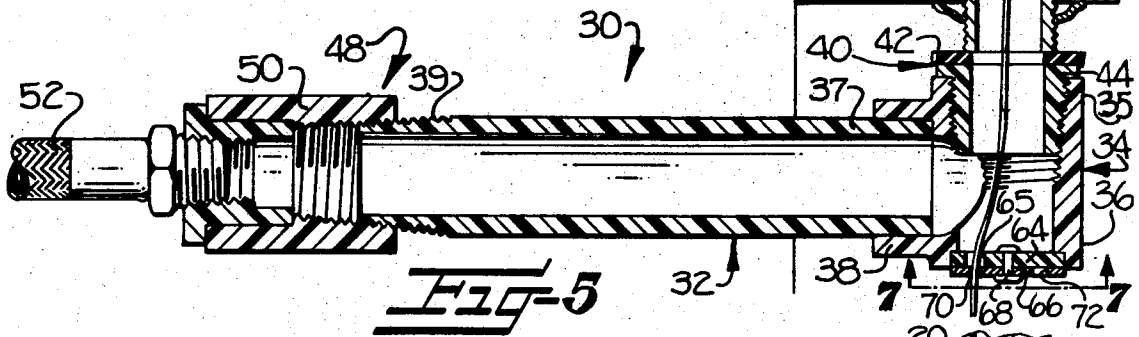
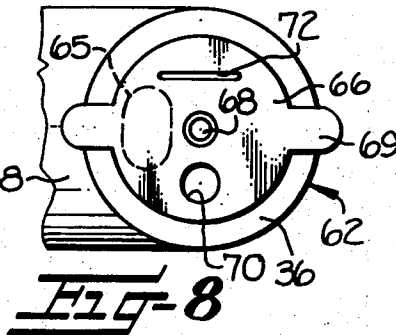
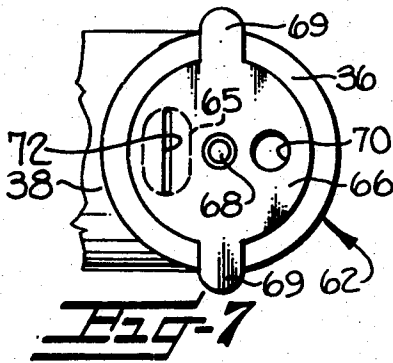

FIG-4

INVENTORS:
 HOWARD G. RUDDICK
 and KENNETH H. LONG

BY *Barrett, Bell, Seltje, Cook & Libson*
 ATTORNEYS



HOWARD G. RUDDICK
and KENNETH H. LONG

BY *Barrett, Bell, Seligson, Park & Johnson*, ATTORNEYS

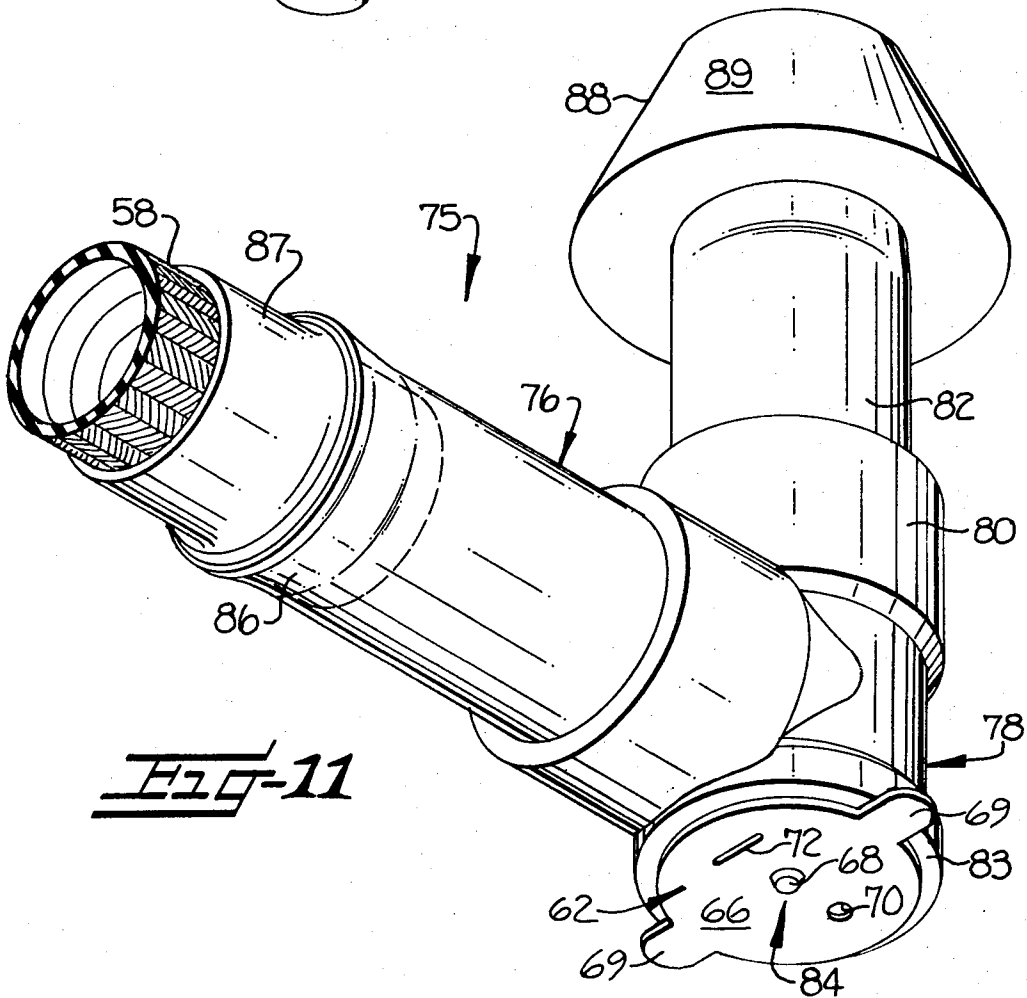
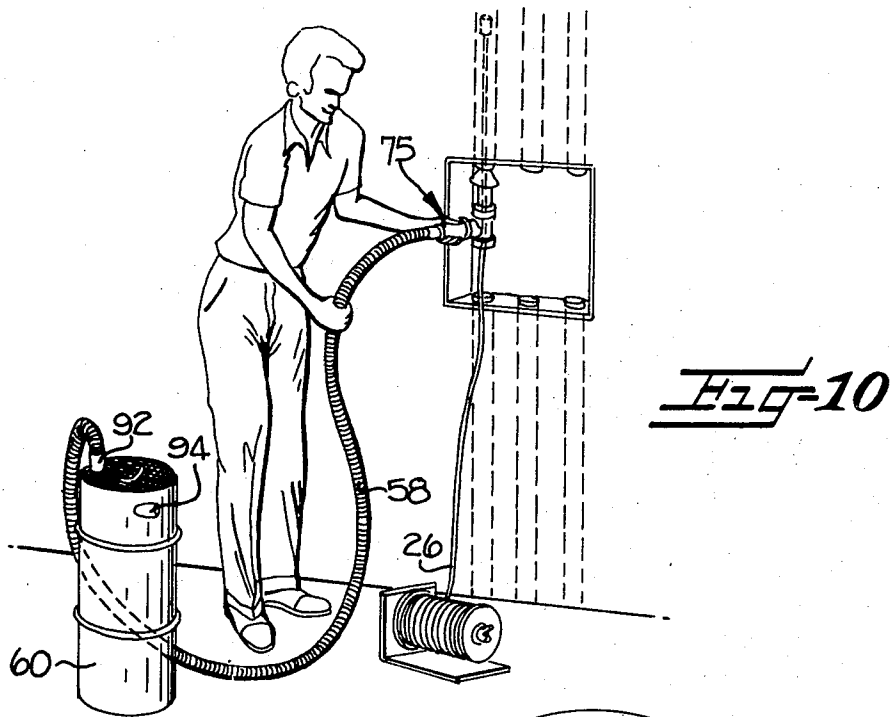

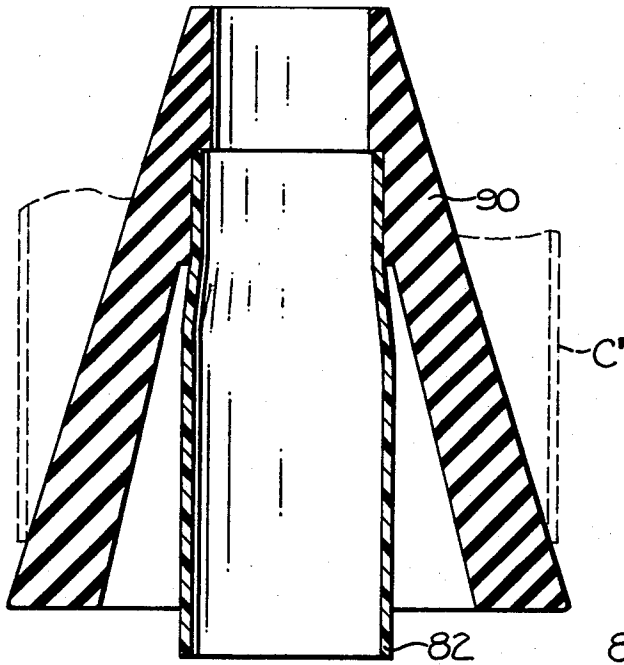

Fig-13

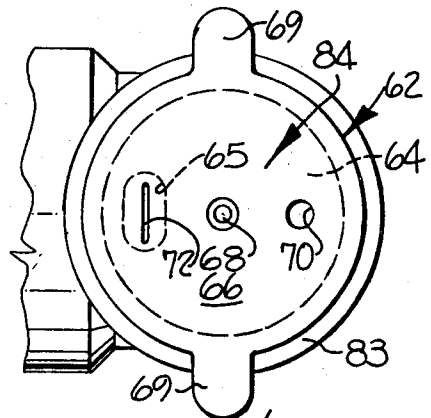

Fig-14

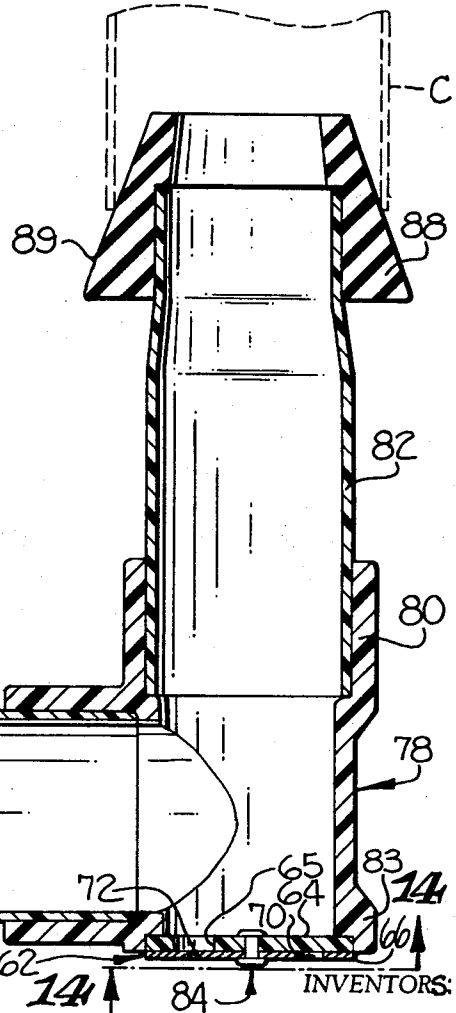

Fig-12

INVENTORS:
 HOWARD G. RUDDICK
 and KENNETH H. LONG

BY *Barnett, Bell, Seligson, Park & Gibson*
 ATTORNEYS

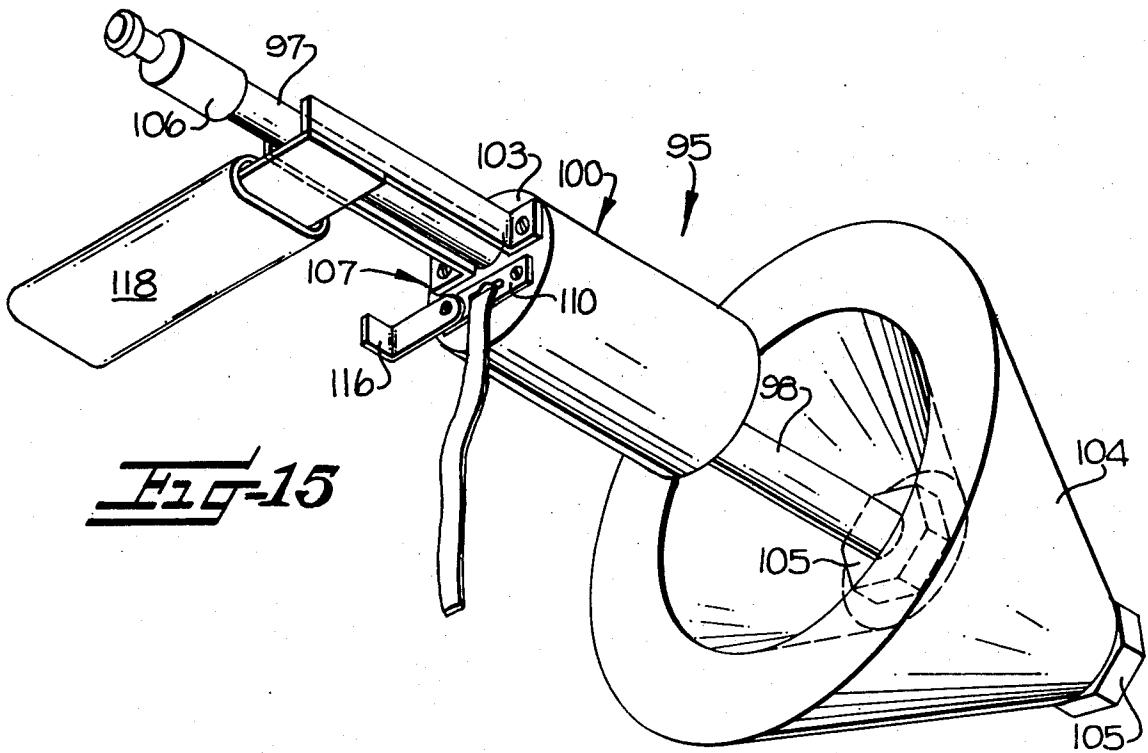

Fig-15

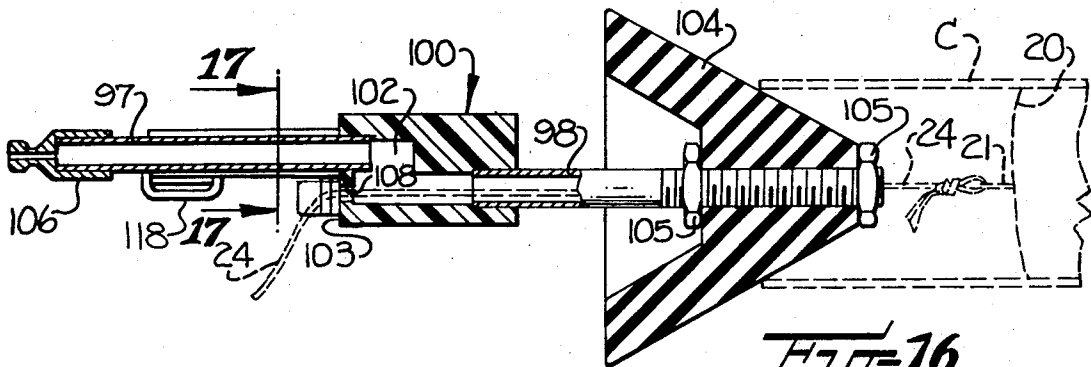

Fig-16

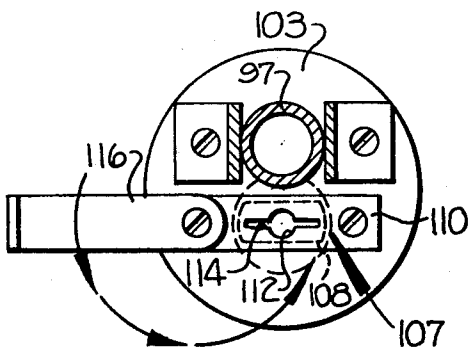

Fig-17

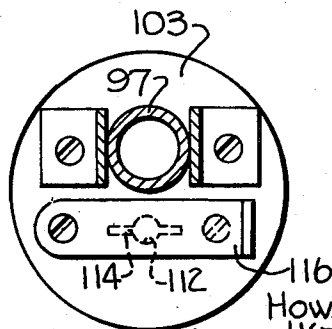

Fig-18

INVENTORS:
HOWARD G. RUDDICK
and KENNETH H. LONG

BY *Ransom, Bell, Seligson, Rank & Gibson*

ATTORNEYS

APPARATUS FOR INSTALLING PULL LINES IN CONDUITS

The present invention relates to an apparatus for installing wiring in an electrical conduit, and more particularly to an adapter designed to efficiently pass either a cordage pull line or a ribbon-like tape pull line through a conduit in response to a fluid pressure differential in the conduit.

In the U.S. Pat. to Corsiglia, No. 3,301,531, which is commonly owned with the present application, there is illustrated a system for placing wires in previously installed electrical conduit by pneumatically threading a cord through the conduit, and subsequently pulling the specified electrical wires through the conduit by means of the cord. The apparatus includes a right angled adapter designed to connect the conduit to an air pressure source, with a generally circular hole extending through the adapter wall for admitting the cord.

While the above apparatus is suitable for use in many applications, it has been found that when a relatively heavy and expensive electrical conductor is to be placed in the conduit, it is preferable to employ a different procedure utilizing a thin plastic tape pull line having measuring indicia thereon, rather than a conventional cord. Under this procedure, the tape is first threaded through the conduit by the differential fluid pressure in the conventional manner, and the length thereof is noted. A heavy pull line of greater strength than the tape is attached to the remote end of the tape and then drawn through the conduit by the tape. The electrical conductor may then be precut to its proper length as determined by the length of the tape, and the precut length is attached to the heavy pull line and drawn into the conduit. This procedure reduces waste of the expensive electrical conductor and is further described in the commonly assigned copending application of James C. Hamrick, Ser. No. 59,224, filed July 29, 1970.

When the above process is employed, an adapter as shown in the Corsiglia patent is unsatisfactory since there will be excessive leakage of the fluid between the tape and the relatively large entry aperture extending through the wall of the adapter. Thus a great deal of the potential fluid pressure is lost, and the remaining pressure may be insufficient to propel the tape pull line the required distance.

Accordingly, it is an object of the present invention to provide an adapter for use in selectively passing either a cordage pull line, or ribbon-like tape pull line, through a conduit in an efficient and economical manner.

It is an additional object of this invention to provide an adapter for use with either type pull line as described above and which is adapted to facilitate the passing of a line carrier and trailing pull line through a substantial length of a conduit by precluding undue fluid leakage through the opening in the adapter wall admitting the pull line.

It is another object of the present invention to provide a selective closure for the opening in the adapter such that the adapter may be used to draw a vacuum in the conduit for pulling a carrier and line therethrough.

It is a further object of the present invention to provide an adapter of the described type which is adapted to be selectively attached either to a source of fluid pressure or to a vacuum source.

It is another object of the present invention to provide an adapter of the described type which is adapted to be used with conduits of varying size or diameter.

These and other objects and advantages of the present invention are achieved in the embodiments of the invention illustrated herein by the provision of a tubular conduit adapter having a wall defining a passageway for transmitting a fluid pressure therethrough, with one end of the adapter being positionable at the entrance end of the conduit and the other end of the adapter being attachable to a source of fluid pressure. A pull line entrance extends through the wall of the adapter for selective introduction into the passageway of either a cordage or tape pull line without undue loss of fluid therethrough, and comprises a first opening closely conforming to the cross-sectional configuration of the cordage pull line, and a second opening closely conforming to the cross-sectional configuration of the tape pull line.

Some of the objects and advantages of the invention have been stated, others will appear as the description proceeds, when taken in connection with the accompanying drawings, in which

FIG. 1 is a fragmentary perspective view of the inside of a building structure and illustrating the manner for using one embodiment of the present invention;

FIG. 2 is an enlarged perspective view of the conduit adapter shown in FIG. 1;

FIG. 3 is a perspective view of an extension member which is adapted to be coupled to one end of the adapter shown in FIG. 2;

FIG. 4 is a perspective view of a hose coupling adapted to be substituted for the coupling shown at the opposite end of the adapter of FIG. 2;

FIG. 5 is a fragmentary sectional top view of the adapter shown in FIG. 2 positioned at the entrance of a conduit and illustrating the manner in which a carrier plug and trailing tape pull line is passed through the conduit;

FIG. 6 is a view similar to FIG. 5 but illustrating the extension member of FIG. 3 secured to one end of the adapter and the hose coupling of FIG. 4 secured to the opposite end of the adapter, and further illustrating a cordage pull line secured to the carrier plug;

FIG. 7 is a fragmentary side elevational view taken substantially along the line 7-7 of FIG. 5 and illustrating the adapter in position to receive the tape pull line;

FIG. 8 is a view similar to FIG. 7 and showing the pull line entrance of the adapter in a closed position;

FIG. 9 is a fragmentary side elevational view, partly broken away, taken substantially along the line 9-9 of FIG. 6 and illustrating the pull line entrance in position to receive the cordage pull line;

FIG. 10 is a view similar to FIG. 1 and illustrating a second embodiment of the present invention;

FIG. 11 is an enlarged perspective view of the conduit adapter shown in FIG. 10;

FIG. 12 is a sectional view of the adapter shown in FIGS. 10 and 11;

FIG. 13 is a sectional view of a second embodiment of the sealing ring for use with the adapter shown in FIGS. 10-12;

FIG. 14 is a fragmentary side elevational view taken substantially along the line 14-14 of FIG. 12 and illustrating the pull line entrance of the adapter shown in FIGS. 10-12 in position to receive the tape pull line;

FIG. 15 is a perspective view of another embodiment of a conduit adapter embodying the features of the present invention;

FIG. 16 is a sectional top view of the adapter shown in FIG. 15;

FIG. 17 is a sectional end view taken substantially along the line 17—17 of FIG. 16 and illustrating the pull line entrance of the adapter in the open position; and

FIG. 18 is a view similar to FIG. 17 and illustrating the pull line entrance in the closed position.

Referring more specifically to the drawings, one embodiment of the present invention is shown in FIGS. 1-9. In FIG. 1, the apparatus is shown threading a pull line through a conduit C which extends through a building structure. The apparatus includes an elongated cylindrical plug or line carrier 20 which is adapted to be blown or vacuumed through the length of the conduit C by the application of fluid pressure differential to one end thereof. The line carrier 20 is of a construction well known in the art, and preferably comprises a flexible and resilient elastomeric foam material. A pin 21 is embedded along the axis of the carrier for securing an end of the trailing pull line thereto. As seen in FIGS. 1 and 5, the pull line comprises a ribbon-like plastic tape 24 of generally thin rectangular cross-section and which preferably includes measuring indicia (not shown) printed or otherwise carried on the surface thereof. A tape of this type is further described in the above noted copending application, Ser. No. 59,244. As shown in FIG. 6, the pull line comprises a conventional cord 26 of generally circular cross-section.

It will be observed in FIG. 1 that a supply of the tape pull line 24 is wound on supply reel 28 disposed on the floor adjacent the opening to the conduit C, and that the pull line 24 extends from the reel 28 through a tubular conduit adapter 30 and into the conduit C where it is tied to the line carrier 20. The adapter 30 includes communicating tubular wall portions 32 and 34 disposed at substantially right angles to each other and which define a passageway adapted to transmit a fluid therethrough. The wall portions may be made from a variety of conventional materials, such as molded polyvinyl chloride, and are permanently interconnected as seen in FIG. 5 by a press fit or the like. The portion 34 is generally T-shaped and includes an internally threaded forward end 35 and a rear end 36 closed by a structure hereinafter further described. The portion 32 in turn includes a forward end 37 connected to the base 38 of portion 34 as described above, and a rear end 39.

The adapter 30 further includes means 40 carried at the forward end 35 of the wall portion 34 for selectively positioning the same in substantially sealed fluid communication with the entrance end of the conduit C. In the embodiment shown in FIGS. 1-9, means 40 includes a resilient flat annular rubber-like ring 42 having a front exposed surface adapted to sealingly engage the conduit at the entrance end thereof. The rear surface of the ring 38 is adhesively secured to a tubular threaded extension member 44, which in turn is threadedly secured in the forward end 35 of the tubular portion 34 to form a continuation of the adapter passageway.

FIG. 3 illustrates an elongated extension member 46 which is adapted to be substituted for the ring 42 and

extension member 44, compare FIGS. 5 and 6. Extension member 46 carries a similar sealing ring 42' at the forward end thereof and a similar threaded member 44' at the rear end thereof, and is useful in certain applications where the entrance end of the conduit C is not readily accessible.

The adapter 30 further includes means 48 at the rear end 39 of the wall portion 32 for selectively attaching the adapter either to a source of fluid pressure or to a vacuum. In particular, means 48 includes external threads at the rear end 39 with the threads adapted to releasably secure an internally threaded coupling member 50, which in turn is secured in the conventional manner to a hose 52 and bottle 54 containing a compressed gas, such as carbon dioxide. As will be apparent from FIGS. 2 and 4, an internally threaded hose coupling 56 may replace the coupling 50, with the hose coupling 56 adapted to connect the adapter 30 to a large diameter flexible hose 58 and blower 60 as shown in FIG. 10.

Again viewing FIGS. 1 and 2, the pull line 24 will be seen to extend through means 62 defining an entrance in the wall of the adapter adjacent the right angled connection or bend, and more particularly at the rear end 36 of wall portion 34. The entrance means 62 at best shown in FIGS. 5 and 9 includes a circular wall member 64 fixedly mounted to close the end 36 and having a generally oval opening 65 extending therethrough. A rotatable wall member 66 is mounted in juxtaposition with the wall member 64 and is rotatably secured thereto by means of the central rivet 68. The wall member 66 includes a pair of tabs 69 along the periphery thereof to assist in rotating the same, and further includes a first circular opening 70 and a second generally thin rectangular opening 72 extending therethrough. It will be observed that the circular opening 70 closely conforms to the cross-sectional configuration of the cordage pull line 26 and the opening 72 similarly conforms to the cross-sectional configuration of the tape pull line 24. By design, the openings 70 and 72 are positioned so that they may be selectively brought into individual communication with the opening 65 in the wall member 64 (compare FIGS. 7 and 9), or they may be positioned such that there is no communication between the openings (as shown in FIG. 8).

In utilizing the described apparatus, the wall member 66 is initially rotated to align the appropriate opening therein with the opening 65 in member 64 according to the particular type of pull line to be employed. When the tape pull line 24 is being utilized, the opening 72 is positioned as shown in FIG. 7 and the line 24 threaded therethrough and attached to the carrier 20. The carrier 20 and attached line are then manually inserted into the conduit C and the forward end 35 of the adapter is forcibly pressed against the entrance end of the conduit to effect a substantially sealed fluid communication therebetween, note FIG. 5. The compressed gas from the bottle 54 is then directed through the adapter 30 by utilizing a conventional manual valve arrangement, to pneumatically force the line carrier and trailing pull line through the conduit. When the carrier reaches the opposite end of the conduit, the operator attaches either the appropriate electrical conductor or a separate heavy duty line, which may then be pulled back through the conduit in accordance with the procedure described above.

A somewhat modified form of the invention is disclosed in FIGS. 10-14 and includes a conduit adapter 75 which is larger in diameter but otherwise generally similar in construction to the adapter 30. The adapter 75 includes communicating wall portions 76 and 78 defining a right angled passageway, with the forward end 80 of portion 78 defining a sleeve for releasably securing a tubular extension 82. The rear end 83 of wall portion 78 mounts means 84 defining a pull line entrance which is similar in construction and operation to the above described means 62 of adapter 30, and the rear end 86 of wall portion 76 is adapted to releasably receive the connector 87 of hose 58.

As seen in FIGS. 11 and 12, the extension member 82 mounts a sealing ring 88 for positioning the forward end of the adapter in substantially sealed fluid communication with the entrance end of the conduit C. The ring 88 is of a resilient rubber-like construction, and defines an external surface 89 of truncated conical shape which is adapted to partially enter and sealingly engage the wall of the conduit. A modified form of the sealing ring is shown at 90 in FIG. 13 for use with a larger diameter conduit C'. As will be apparent, the axial length of the sealing ring 90 has been extended to increase its maximum outer diameter for use with large conduits.

When the adapter 75 is connected to the exhaust port 92 of the blower 60, it is utilized in the same manner as described above with regard to the adapter 30 to push the carrier 20 and pull line through the conduit. Alternatively however, the hose 58 may be connected to the entrance or vacuum port 94 of the blower 60 to vacuum or draw a carrier and pull line through the conduit. More particularly, the carrier and pull line would be inserted into the remote end (not shown) of the conduit, and the entrance means 84 on the adapter would be positioned such that the two openings therein are closed. By drawing a vacuum through the hose 58, the carrier and pull line will be drawn through the conduit toward the adapter 75. It will be apparent that the adapter 30 may also be utilized in this manner by connecting the hose 58 to the vacuum port of the blower 60.

Still another embodiment of the present invention is disclosed in FIGS. 15-18, and includes an adapter 95 comprising interconnected tubular wall portions 97 and 98. The two wall portions are parallel but laterally off-set in the manner shown in FIG. 16, and are joined by the centrally located connector 100. The connector 100 includes a central bore 102 for effecting communication between the two wall portions, and defines a rear end wall 103.

The forward end of the wall portion 98 mounts a sealing ring 104 by a structure which includes external threads on the wall portion and a pair of mating nuts 105 as seen in FIG. 16. The rear end of the wall portion 97 carries a coupling 106 for releasably connecting the same to a source of fluid pressure in the conventional manner.

Means 107 defining a pull line entrance extends through wall 103 for selective introduction of either the cordage pull line 26 or tape pull line 24 without undue loss of fluid therethrough, and includes an aperture 108 in the wall 103 and a plate 110 secured to the wall and overlying the aperture 108. As best seen in FIG. 17, the plate 110 includes a first generally circular opening 112

which closely conforms to the cross-sectional configuration of the cordage pull line, and a second opening 114 of a thin rectangular cross-section which generally conforms to the cross-sectional configuration of the tape pull line. The first and second openings have portions thereof coinciding such that the total area thereof is less than the sum of the individual areas of the two openings. Also, the two openings 112 and 114 will be seen to overlie the aperture 108 to provide an entrance into the bore 102. By this arrangement, either the cordage pull line or the tape pull line may be selectively introduced through the entrance means such that there is a relatively small clearance permitting leakage of fluid outwardly past the entering pull line.

A cover 116 is hingedly mounted to the plate 110 adjacent the entrance means 107 to selectively close the same (as shown in FIG. 18) when it is desired to employ the adapter 95 to vacuum a carrier and pull line through the conduit in the manner described above. In addition, a transversely extending handle 118 may be secured to the wall 103 of the adapter in the manner shown in FIG. 15 to facilitate retention of the same by a user.

In the drawings and specification, there has been set forth a preferred embodiment of the invention, and although specific terms are employed, they are used in a generic and descriptive sense only and not for purposes of limitation.

What is claimed is:

1. An apparatus for selectively passing a cordage pull line of generally circular cross section, or a tape pull line of generally thin, rectangular cross section, and secured to a carrier plug, into and through a conduit in response to a fluid pressure differential therein, said apparatus comprising

a conduit adapter having a wall defining a passageway for transmitting a fluid therethrough, means at one end of said adapter for positioning the same in fluid communication with the entrance end of the conduit, and means at the other end of the adapter for selectively attaching the same to a source of fluid pressure or a vacuum, and

means defining an entrance extending through said wall intermediate the ends of the adapter for selective introduction into the fluid passageway of the cordage pull line or tape pull line without undue loss of fluid therethrough, said entrance means comprising a first opening closely conforming to the cross-sectional configuration of the cordage pull line and a second opening extending parallel to said first opening and closely conforming to the cross-sectional configuration of the tape pull line.

2. The apparatus as defined in claim 1 wherein said first and second openings are spaced, and said apparatus further including means for selectively covering either one of said openings.

3. The apparatus as defined in claim 1 wherein said first and second openings are spaced, and said apparatus further including means for selectively covering either one or both of said openings.

4. The apparatus as defined in claim 1 wherein said first and second openings have portions thereof coinciding such that the total area of said first and second openings is less than the sum of the individual areas of the same.

5. The apparatus as defined in claim 4 further including means for selectively covering both of said openings.

6. The apparatus as defined in claim 4 further comprising a cover hingedly mounted adjacent said entrance means to selectively close the same.

7. The apparatus as defined in claim 4 wherein a transversely extending handle is secured to said adapter to facilitate retention of the same by the user.

8. An apparatus for selectively passing either a cordage pull line of generally circular cross-section, or a tape pull line of generally thin, rectangular cross-section, and secured to a carrier plug, into and through a conduit in response to a fluid pressure differential therein, said apparatus comprising

a tubular conduit adapter including a wall defining a passageway for transmitting a fluid therethrough, and having a generally right angled bend intermediate the ends thereof, means at one end of said adapter for selectively positioning the same in substantially sealed fluid communication with the entrance end of a conduit, and means at the other end of the adapter for selectively attaching the same to either a source of fluid pressure or a vacuum, and

means defining an entrance extending through said wall adjacent said bend for selective introduction into the fluid passageway of the cordage pull line or tape pull line without excessive loss of fluid therethrough, said entrance means comprising a first wall having first and second spaced openings extending therethrough, said first opening closely conforming to the cross-sectional configuration of

the cordage pull line and said second opening closely conforming to the cross-sectional configuration of the tape pull line, and means for selectively either covering one of said openings while permitting passage of the appropriate pull line through the other of said openings or covering both of said openings.

9. The apparatus as defined in claim 8 wherein said means for selectively covering said openings comprises a second wall member, said first and second wall members being mounted in juxtaposition and being movable relative to each other.

10. The apparatus as defined in claim 9 wherein said second wall member includes an aperture therein adapted to selectively communicate with either of said first and second openings while closing the other opening, or to be positioned intermediate said openings and close both said openings.

11. The apparatus as defined in claim 8 wherein said means for positioning the adapter in communication with the entrance end of the conduit comprises a resilient sealing ring defining an external surface of truncated conical shape adapted to partially enter and sealingly engage the wall of the conduit at the entrance end thereof.

12. The apparatus as defined in claim 8 wherein said means for positioning the adapter in communication with the entrance end of the conduit comprises a resilient flat annular ring defining a front surface adapted to sealingly engage the entrance end of the conduit.

* * * * *

35

40

45

50

55

60

65