



(19) **United States**

(12) **Patent Application Publication**  
**Biondi et al.**

(10) **Pub. No.: US 2002/0026941 A1**

(43) **Pub. Date: Mar. 7, 2002**

(54) **VENTILATOR CONTROL SYSTEM AND METHOD**

ation No. 08/569,919, filed on Dec. 8, 1995, now Pat. No. 5,931,160.

**Publication Classification**

(76) Inventors: **James W. Biondi**, North Haven, CT (US); **Douglas M. Johnston**, Winchester, MA (US); **Gerhardt P. Schroeder**, Londonderry, NH (US); **Donald D. Gilmore**, Kiehi, HI (US); **Robert Reynolds**, New Haven, CT (US)

(51) **Int. Cl.<sup>7</sup>** ..... **A62B 7/00**; A61M 16/00; F16K 31/02  
(52) **U.S. Cl.** ..... **128/204.21**; 128/204.18

(57) **ABSTRACT**

The invention features an exhalation assist device for adjusting the airway resistance in an exhalation circuit of a medical ventilator. The device includes a set of pressure, airflow and airway sensors, a controlling processor, a user interface, and a ventilatory unit in communication with a medical ventilator. Data relating to pressure within the ventilatory unit and data relating to exhalation airflow, exhalation circuit pressure and exhalation circuit resistance are provided to the controlling processor by the sensors. The controlling processor compares measured and calculated values for airway pressure, airflow, airway resistance and applied negative pressure with desired values that have been entered by a clinician. Based on these calculations, the controlling processor transmits a signal that will change the applied negative pressure applied to the exhalation circuit by the ventilatory unit. The amount of negative pressure applied during the breathing cycle is varied by the controlling processor so that the amount of exhalation assist increases proportionately with the amount of exhalation flow and so that the amount of pressure within the patient airway remains constant at a level greater than zero and less than PEEP.

Correspondence Address:

**TESTA, HURWITZ & THIBEAULT, LLP**  
**HIGH STREET TOWER**  
**125 HIGH STREET**  
**BOSTON, MA 02110 (US)**

(21) Appl. No.: **09/931,572**

(22) Filed: **Aug. 14, 2001**

**Related U.S. Application Data**

(63) Continuation of application No. 09/660,820, filed on Sep. 13, 2000, which is a continuation of application No. 09/045,461, filed on Mar. 20, 1998, now Pat. No. 6,158,432, which is a continuation-in-part of appli-

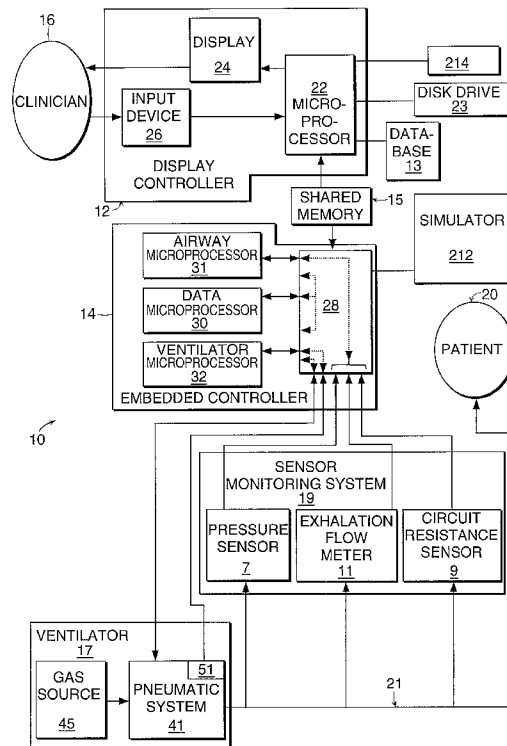

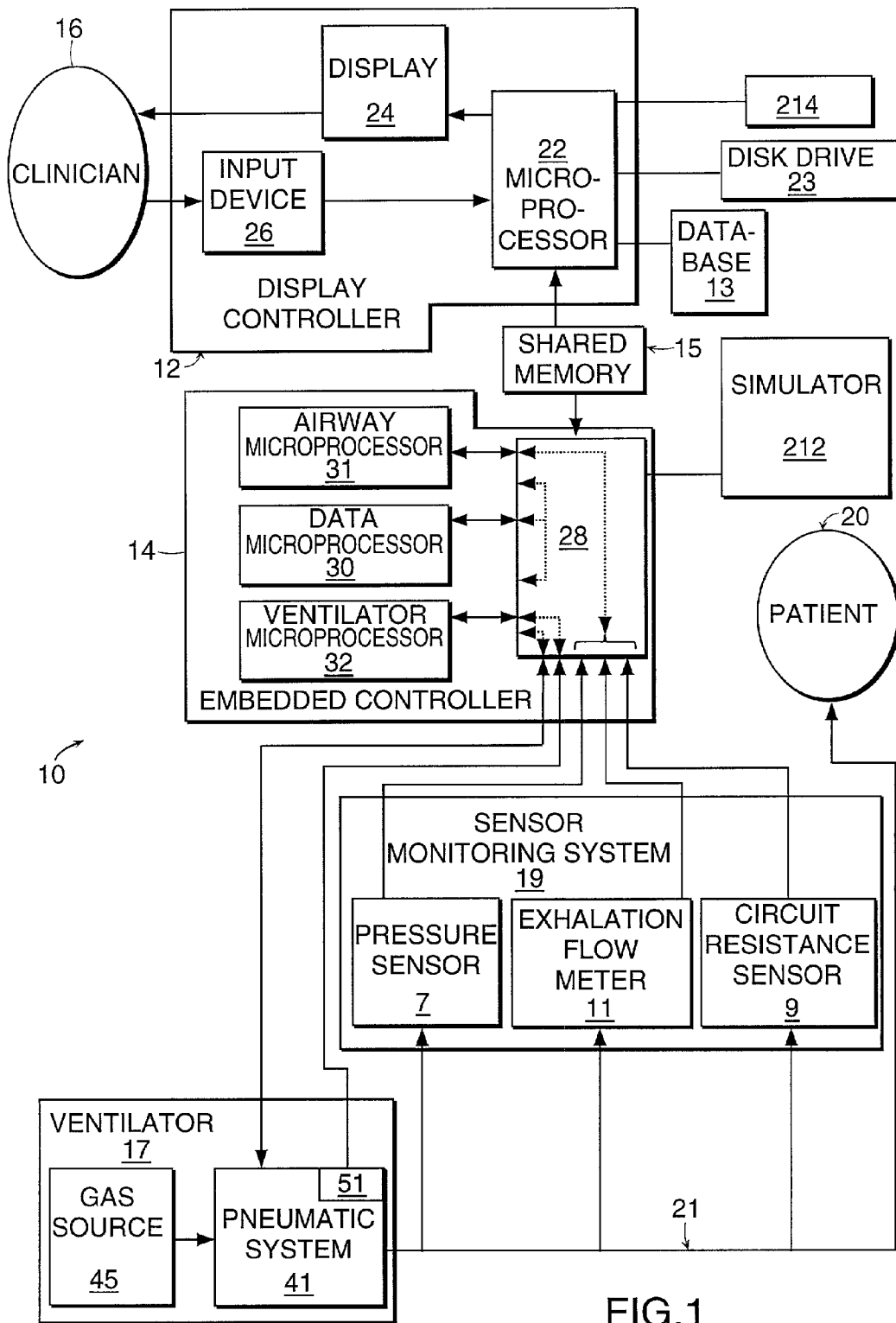

FIG.1

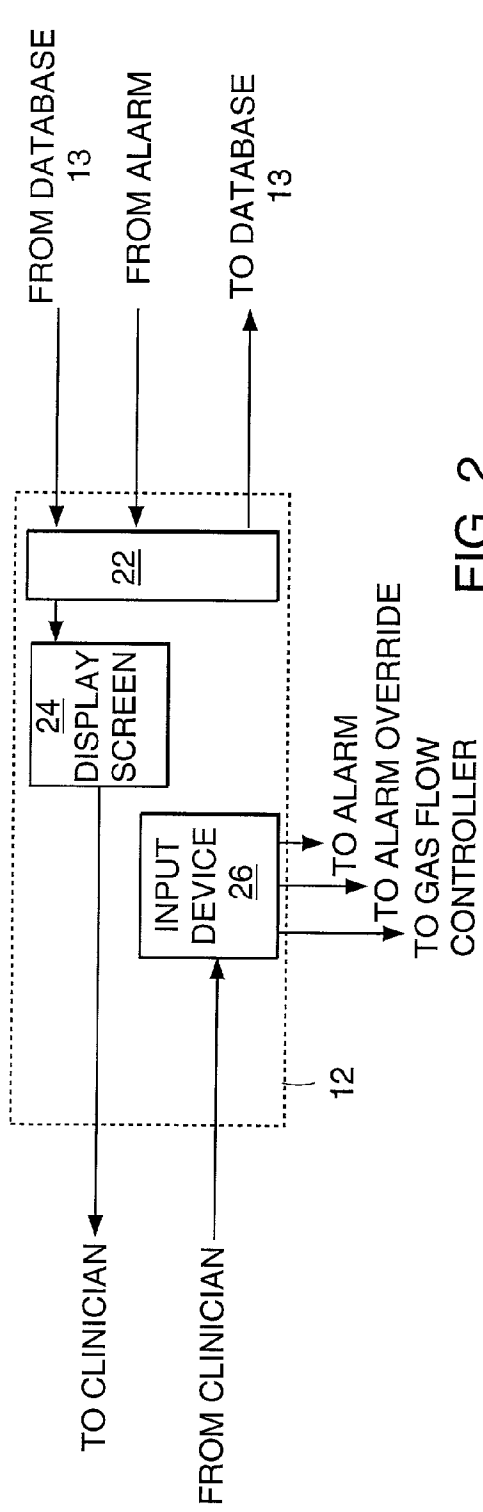

FIG. 2

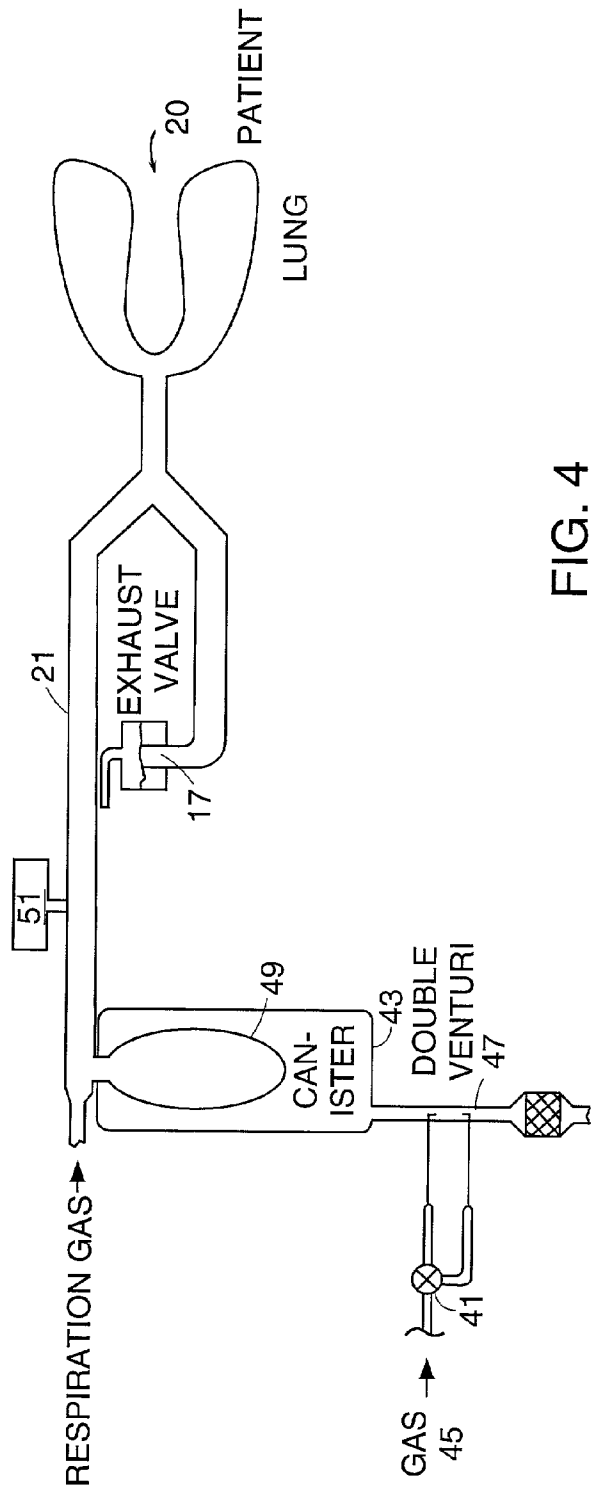

FIG. 4

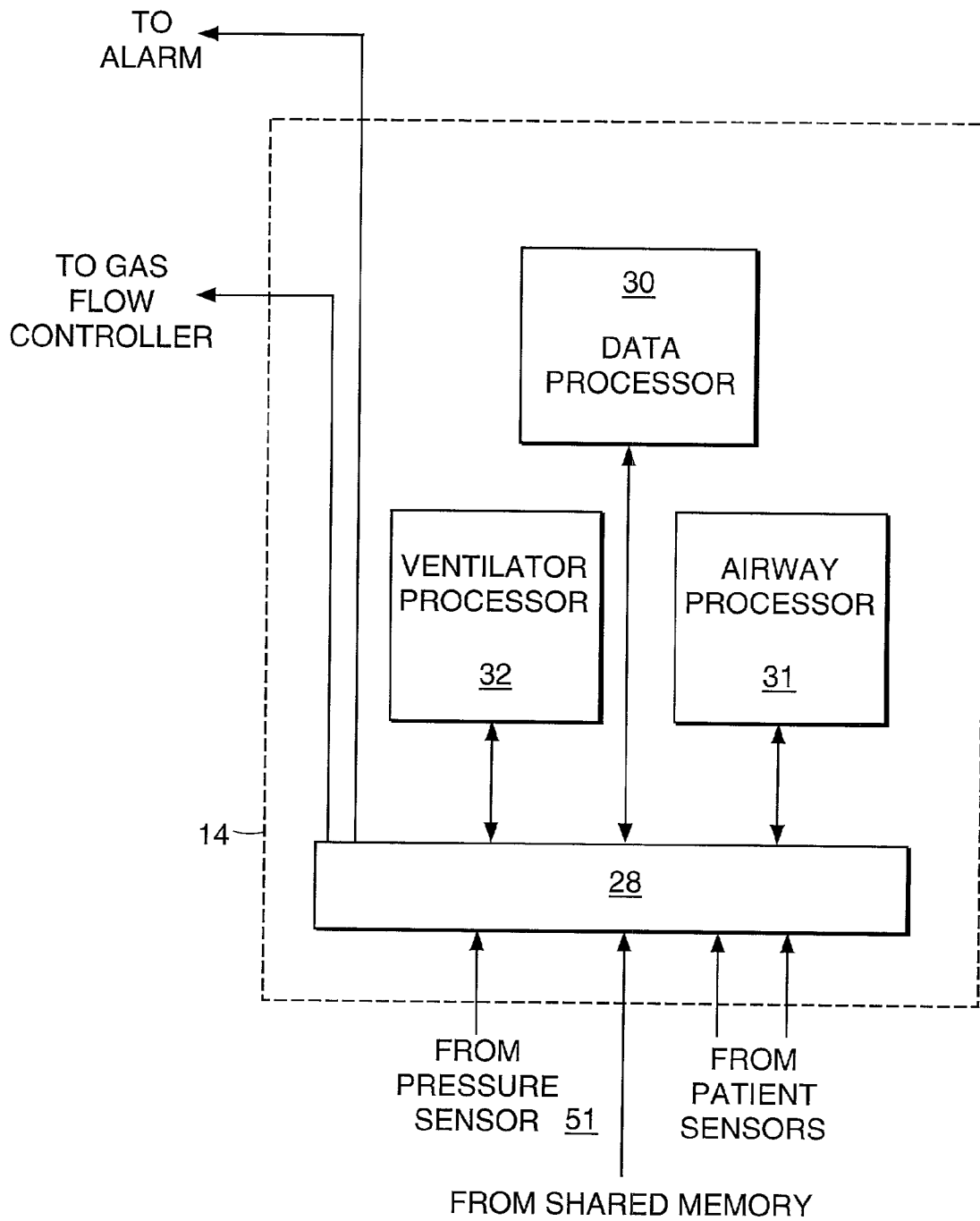

FIG. 3

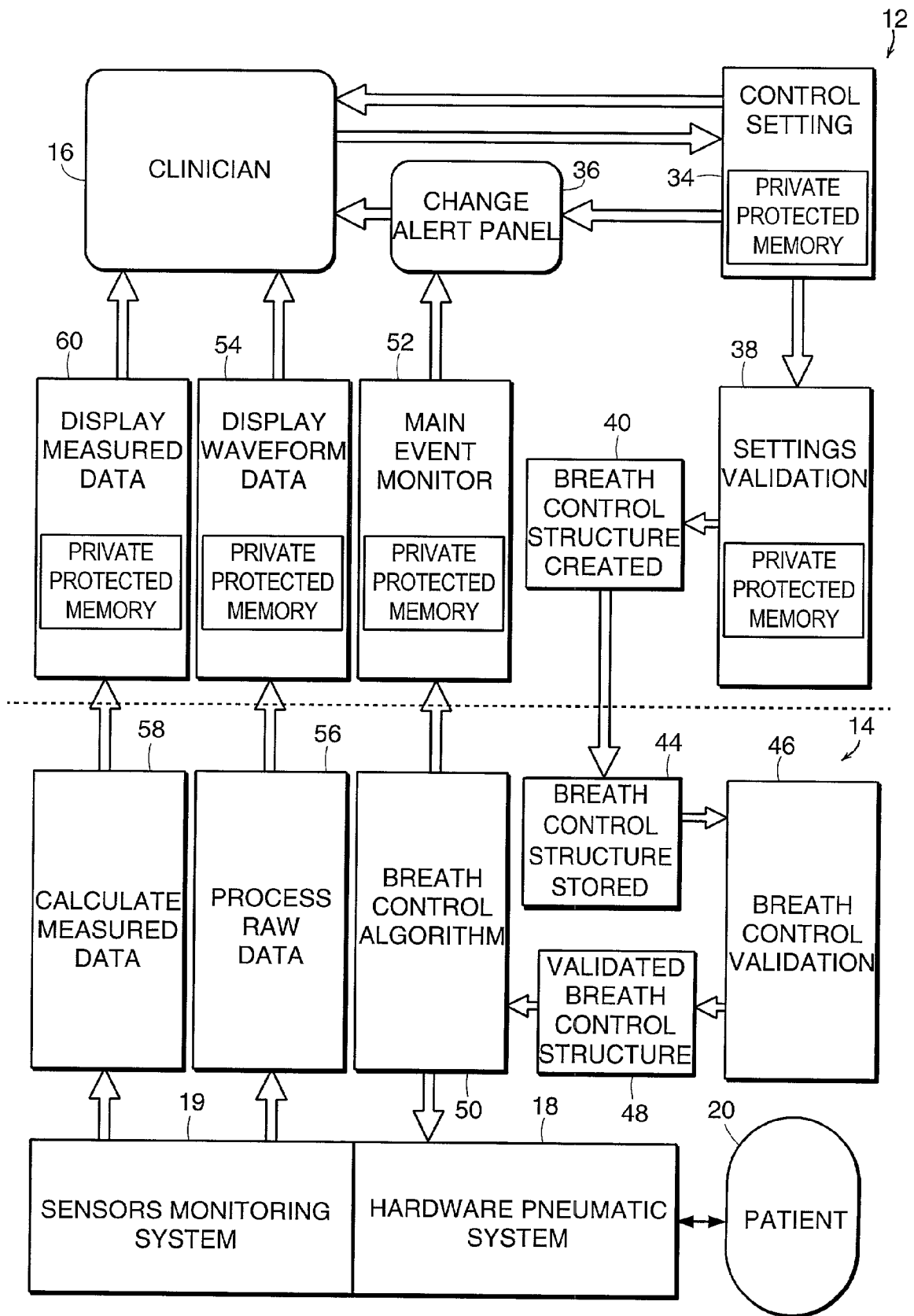

FIG. 5

IF ((FLOW SLOPE INCREASING) (STEP 300)  
AND (PRESSURE SLOPE DECREASING)  
THEN (ADD INHALED VOLUME TO  
TO EVENT VOLUME = (VOLUME - BASELINE))  
ELSE (ADD (0) TO EVENT  
VOLUME = (VOLUME-BASELINE))

IF (EVENT VOLUME > TRIGGER VOLUME) (STEP 310)  
THEN (TRIGGER FLAG = YES)

IF (TRIGGER FLAG = YES) (STEP 320)  
THEN ((IF TIME > 200mSEC) THEN (TRIGGER FLAG = NO)  
ELSE (ADD TO VOLUME = (VOLUME - BASELINE)))

IF (VOLUME > TRIGGER VOLUME) (STEP 330)  
THEN (INITIATE BREATH))  
ELSE (DO NOT INITIATE BREATH)

FIG. 6

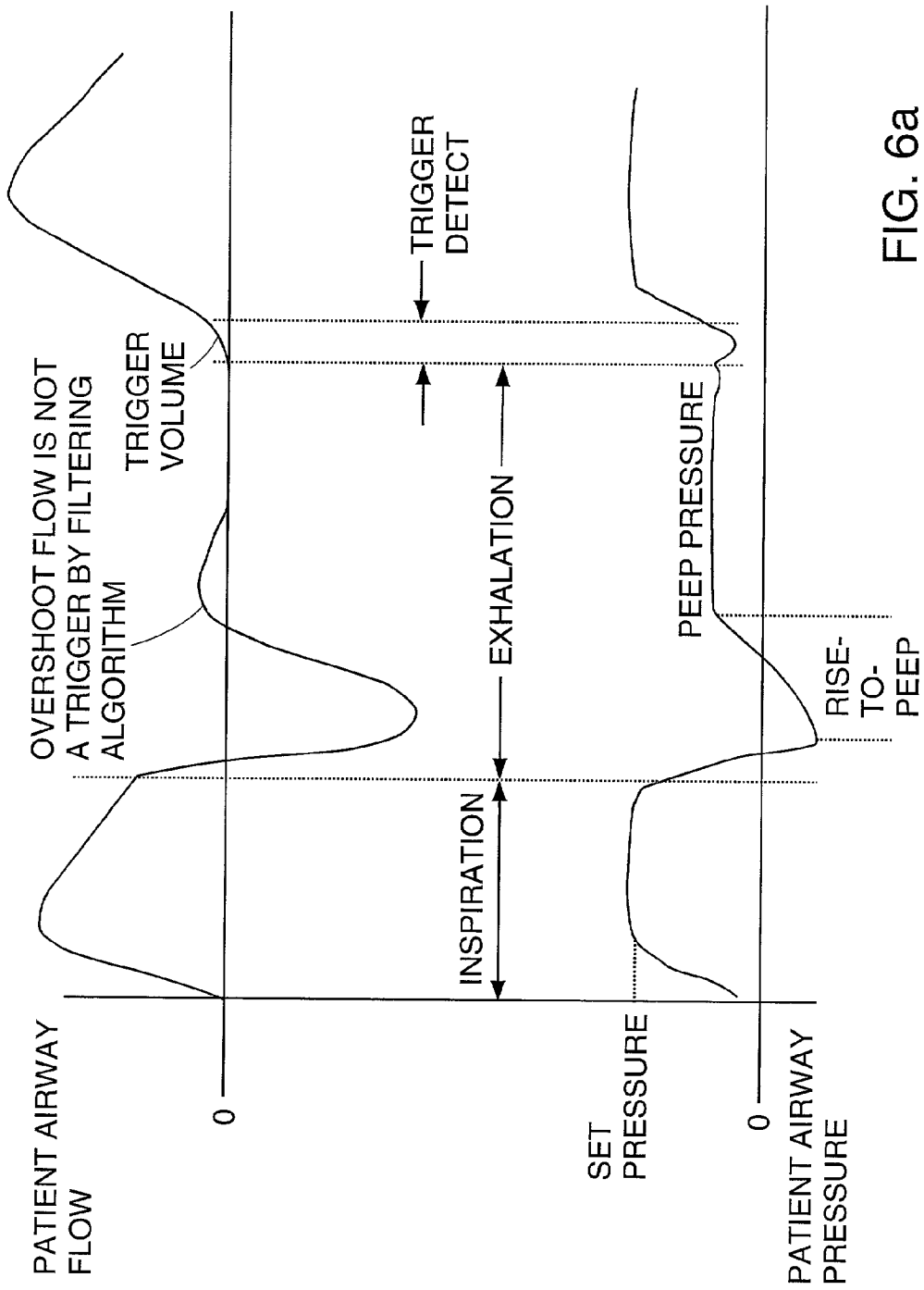

FIG. 6a

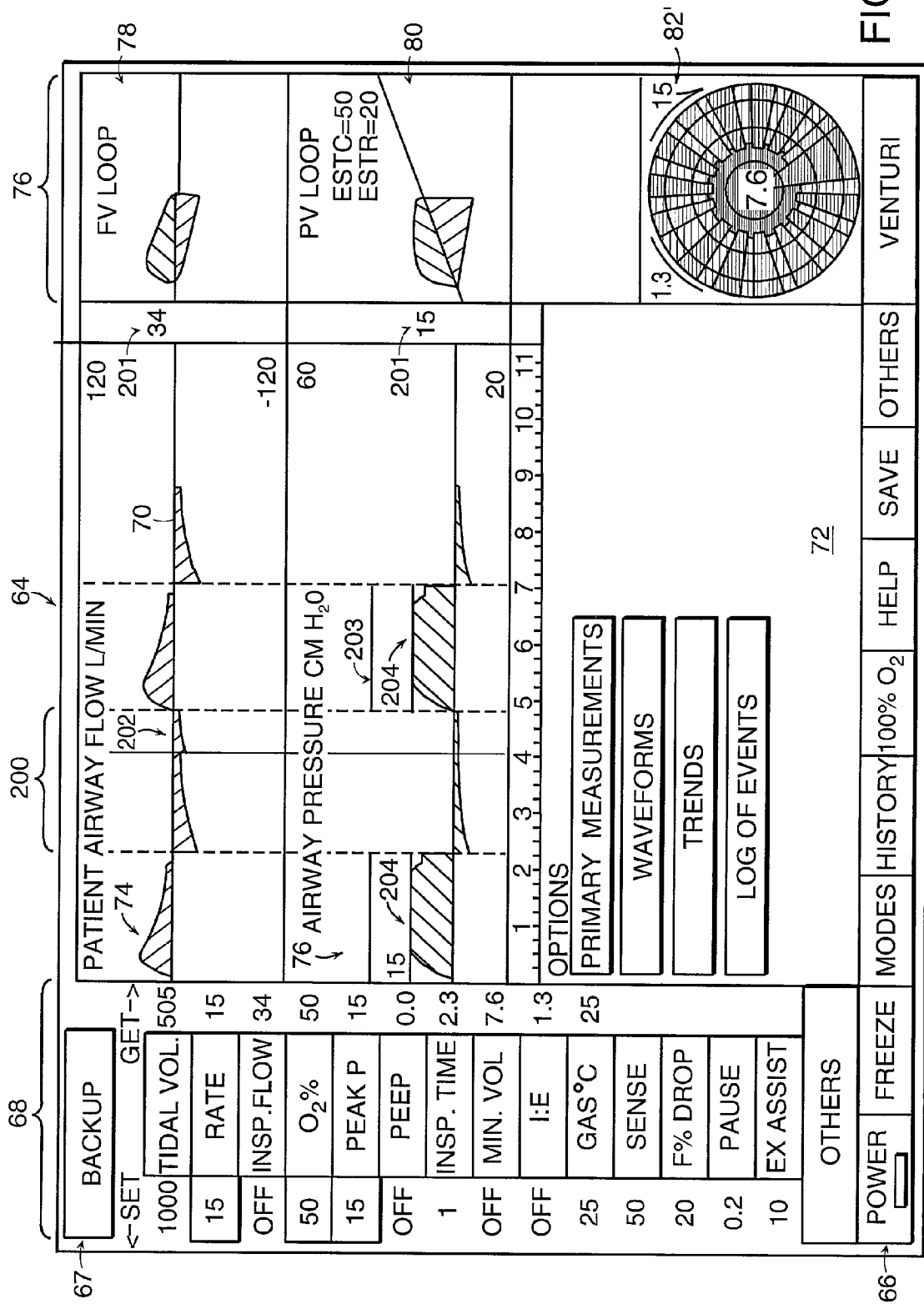

FIG. 7



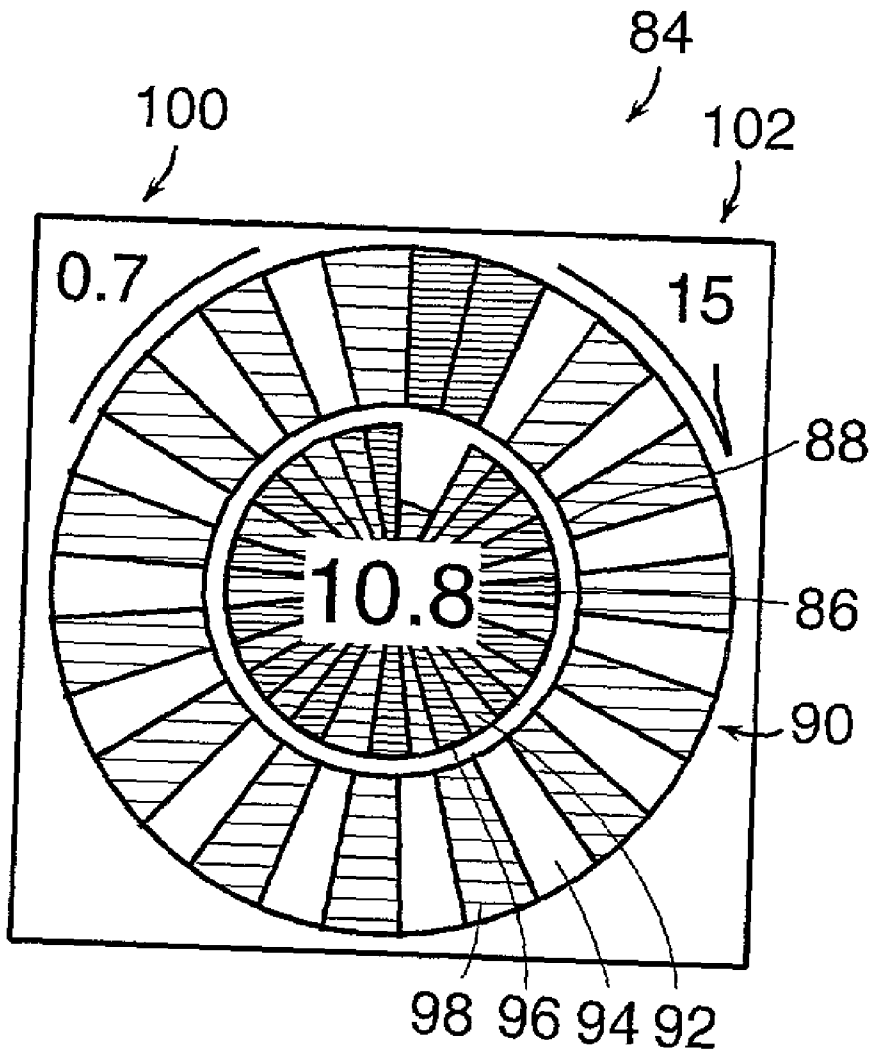

FIG. 8

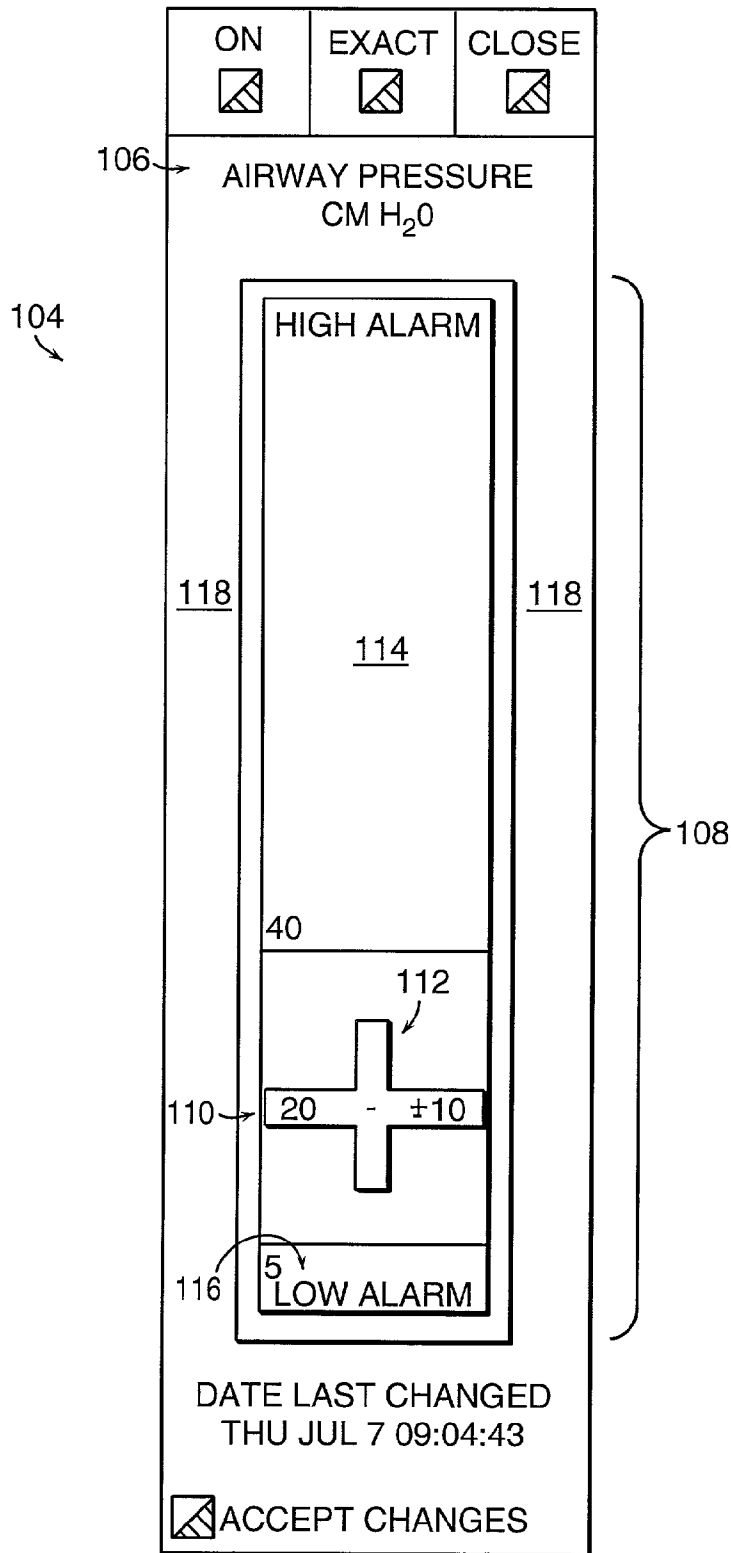

FIG. 9

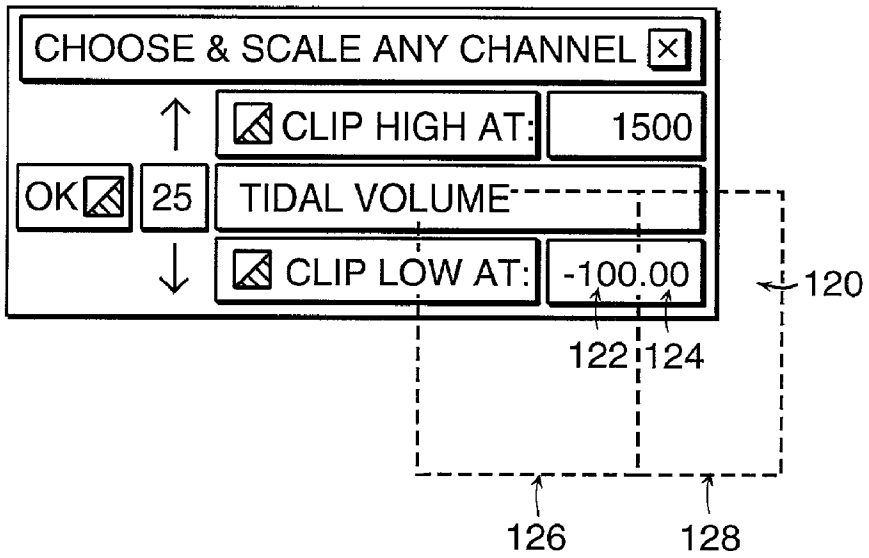

FIG. 10

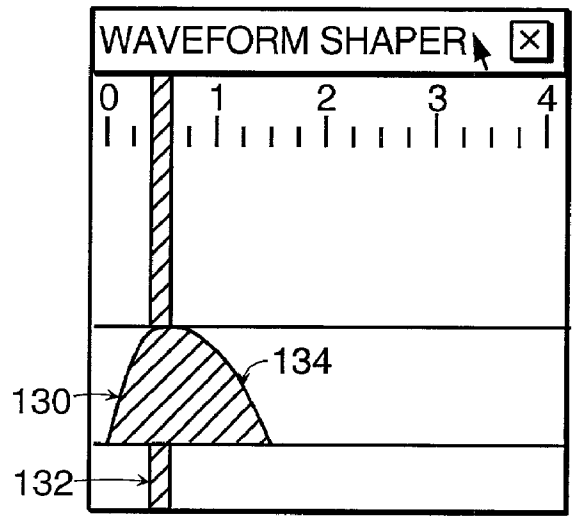

FIG. 15

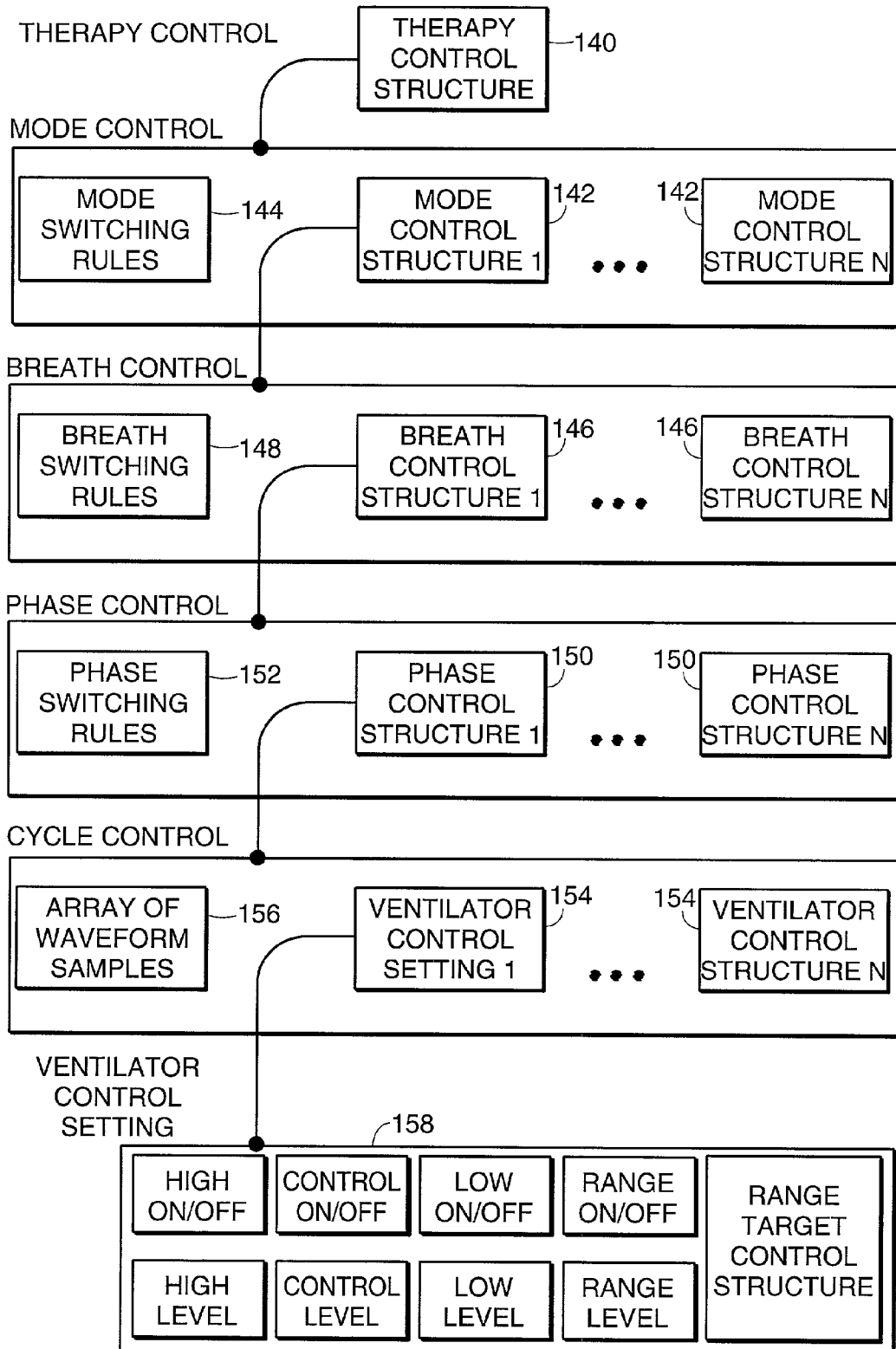

FIG. 11

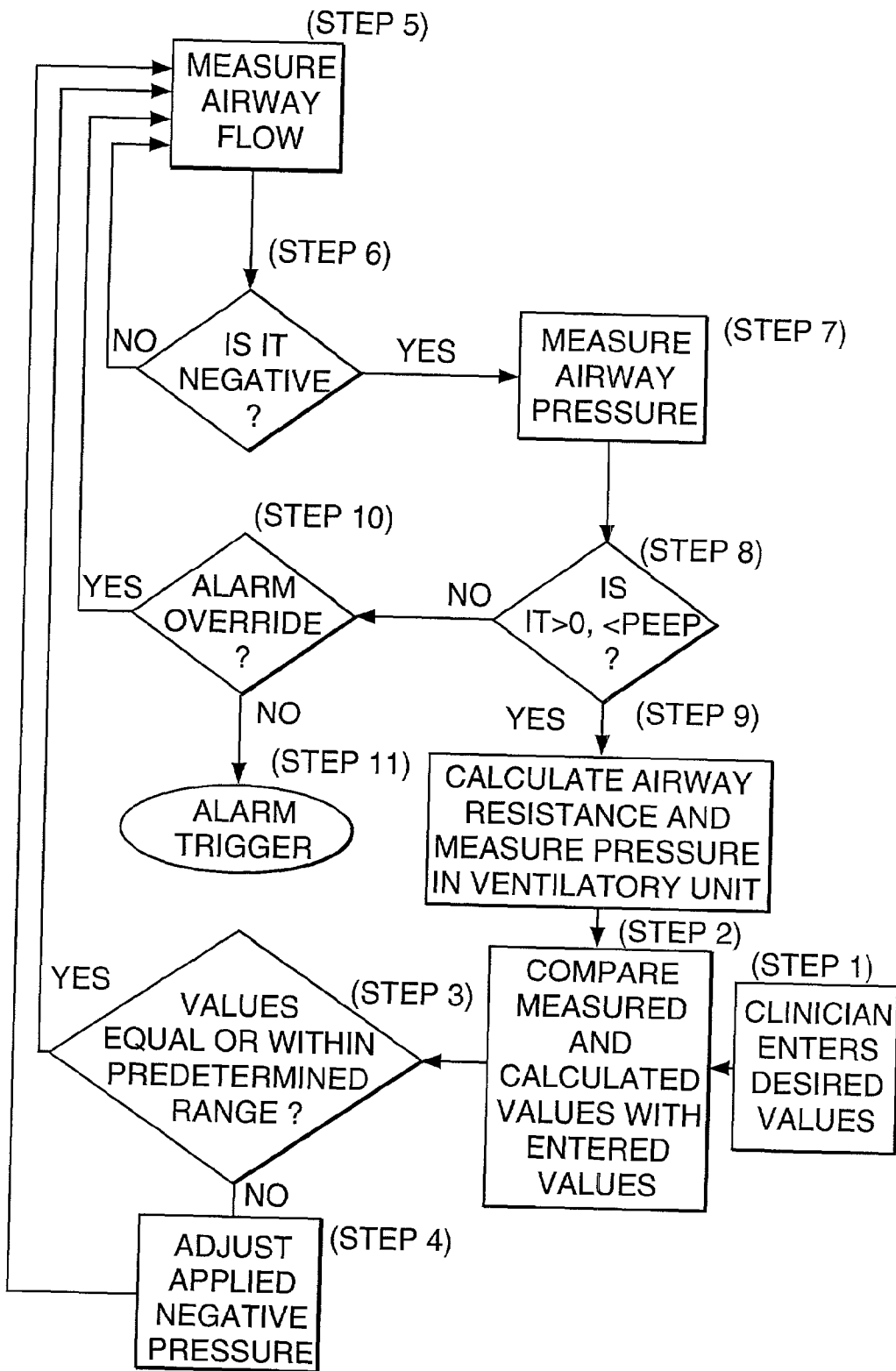

FIG. 12



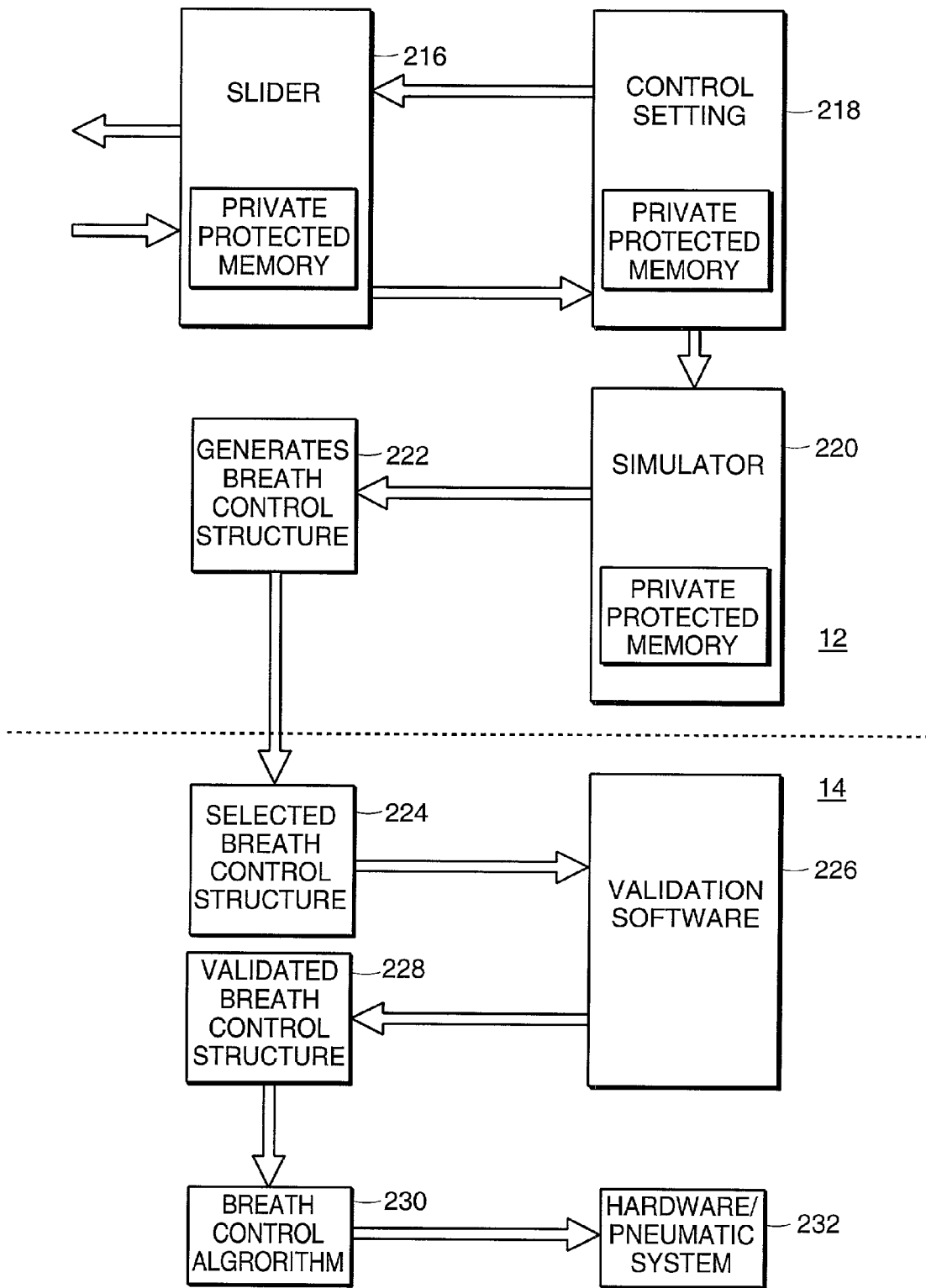

FIG. 14

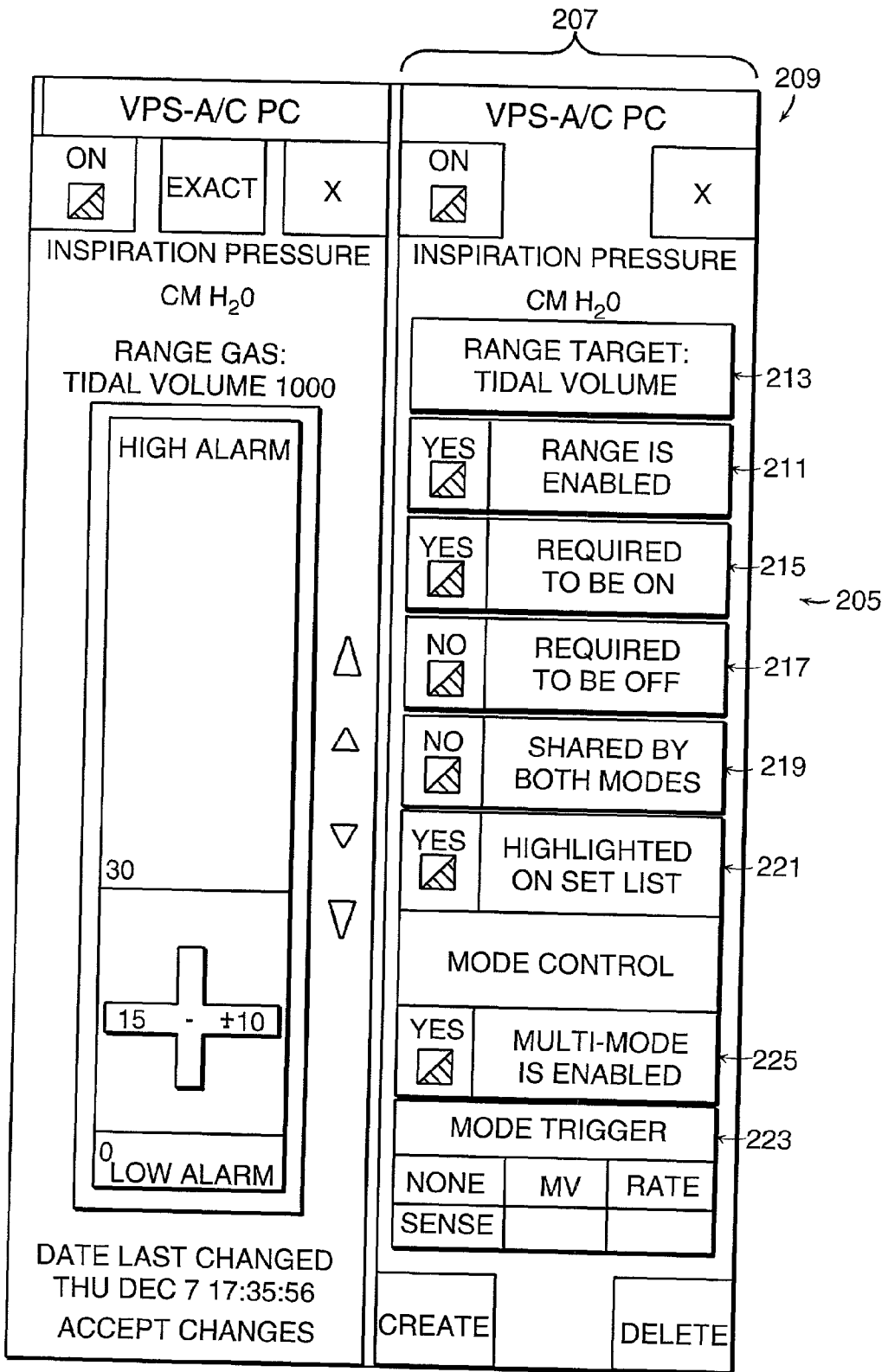

FIG. 16



## VENTILATOR CONTROL SYSTEM AND METHOD

### FIELD OF THE INVENTION

[0001] The invention relates generally to the field of respiratory assist devices such as ventilators. In particular, the invention relates to a ventilator control system and method for controlling a ventilator pneumatic system.

### BACKGROUND OF THE INVENTION

[0002] A medical ventilator delivers gas to a patient's respiratory tract and is often required when the patient is unable to maintain adequate ventilation. Mechanical ventilation is the single most important therapeutic modality in the care of critically ill patients. Known ventilators typically include a pneumatic system that delivers and extracts gas pressure, flow and volume characteristics to the patient and a control system (typically consisting of knobs, dials and switches) that provides the interface to the treating clinician. Optimal support of the patient's breathing requires adjustment by the clinician of the pressure, flow, and volume of the delivered gas as the condition of the patient changes. Such adjustments, although highly desirable, are difficult to implement with known ventilators because the control system demands continuous attention and interaction from the clinician.

[0003] Further, patients requiring ventilatory assistance must overcome airway resistance in the breathing circuit during exhalation. This resistance, combined with the stiffness of the lungs and the thoracic cage under certain pathological conditions, imposes a significant workload upon a patient whose reserves may already be compromised by underlying disease processes. The present invention reduces patient work of breathing without compromising patient ventilation requirements.

### SUMMARY OF THE INVENTION

[0004] The invention relates to a ventilatory assist device that decreases the resistance to exhalation in the exhalation circuit of a medical ventilator. The device adjusts the resistance within the exhalation circuit by generating a negative pressure around a gas exchange reservoir. The negative pressure is then transmitted to the exhalation circuit. In order to keep the resistance constant with varying amounts of exhalation flow, the device varies the amount of applied negative pressure proportionately with increases in exhalation flow.

[0005] In one embodiment of the invention, the clinician enters a desired set of values relating to airway pressure, airway resistance or applied negative pressure through a control panel. A microprocessor within the data processing unit of the device compares these values with data for airway pressure, airway resistance and applied negative pressure that have been measured or calculated by sensors within the device. The microprocessor then adjusts the amount of negative pressure to be created within the gas exchange reservoir that communicates with the patient airway. In one embodiment of the device, negative pressure around the gas exchange reservoir is produced within a rigid canister by varying the airflow through a Venturi valve. In this embodiment, a gas flow controller regulates the flow through the Venturi valve in response to signals it receives from the microprocessor within the data processing unit that calcu-

lates the amount by which the applied negative pressure is to be changed. A pressure sensor in communication with the ventilatory unit measures the negative pressure applied to the gas exchange reservoir and transmits these data to the data processing unit.

[0006] A method of exhalation assist compensates for resistance to gas flow encountered by a patient requiring assisted or controlled ventilation. The method accomplishes this by first determining the instantaneous flow of exhaled gas, the instantaneous pressure within the exhalation circuit and the instantaneous resistance to air outflow so that these data can be compared with desired values entered by a clinician. Negative pressure is applied to the exhalation circuit so as to alter the measured values to reach the desired values.

[0007] The term "ventilator control setting structure" is defined as a collection of information sufficient to control one parameter of ventilation including one or more of: high alarm level, high alarm active, control level, control level active, low alarm level, low alarm active, range level, range level active, and a range target control structure. The range target control structure defines how and why the parameter is to be adjusted automatically within the specified range. The term "cycle control structure" is defined as a collection of waveform samples and a ventilator control setting Structure for each parameter. The term "phase control structure" is defined as a collection of phase switching rules that defines how the ventilator control settings are to be utilized and a ventilator control setting for each controllable parameter that exists in the ventilator. Each phase has one or more triggers that are tested every cycle (4 Msecs per cycle) to decide which ventilator control setting to use.

[0008] The term "breath control structure" is defined as a collection of phase switching rules that defines how and when one ventilatory breath phase is to switch to another ventilatory breath phase and a phase control structure for each phase of breath defined by the specified breath. Breath phases break up a ventilatory breath into as many phases as desired in order to control inspiration, pause, expiration assist and PEEP with any desired level of control for the specified breath. Each breath has one or more triggers that are tested every cycle (4 Msecs per cycle) to decide whether or not to jump to the beginning of a new phase control structure.

[0009] The term "mode control structure" is defined as a collection of breath switching rules that defines how and when one ventilatory breath is to switch to another ventilatory breath and a breath control structure for each type of breath defined by the specified mode of ventilation. Each mode has one or more triggers that are tested every cycle (4 Msecs per cycle) to decide whether or not to jump to the beginning of a new breath control structure.

[0010] The term "therapy control structure" is defined as a collection of mode switching rules that defines how and when one mode of ventilation is to switch to another mode of ventilation and one mode control structure for each ventilation mode defined by the specified therapy. Also, the term "breath parameter" is defined as at least one of a control setting and an alarm setting.

### BRIEF DESCRIPTION OF THE DRAWINGS

[0011] The foregoing and other objects, features and advantages of the invention will become apparent from the

following more particular description of preferred embodiments of the invention, as illustrated in the accompanying drawings.

[0012] FIG. 1 is a block diagram of an embodiment of a ventilator of the invention.

[0013] FIG. 2 is a detailed block diagram of a display controller.

[0014] FIG. 3 is a detailed block diagram of an embedded controller.

[0015] FIG. 4 is a detailed block diagram of a ventilator pneumatic unit.

[0016] FIG. 5 is a diagram illustrating an embodiment of the adjustment of negative pressure applied to a patient as performed by an embodiment of the invention.

[0017] FIG. 6 is pseudocode of an embodiment of a triggering algorithm used by the ventilator of the invention.

[0018] FIG. 6a is a pressure and flow diagram of the patient airway gas flow and patient airway pressure used by the algorithm of FIG. 6 to determine patient ventilation triggering.

[0019] FIG. 7 is an illustration of a display screen when the ventilator control system is in the operational mode.

[0020] FIG. 8 is an illustration of a section of the display screening showing a minute volume wheel.

[0021] FIG. 9 is an illustration of a section of the display screening showing a control slider.

[0022] FIG. 10 is an illustration of a section of the display screening showing a numerical controller.

[0023] FIG. 110 is a flow chart of the data structure hierarchy employed by the ventilator control system.

[0024] FIG. 12 is an embodiment of a flow chart of an exhalation assist algorithm executed by an embodiment of the invention.

[0025] FIG. 13 is an illustration of a simulation mode display screen for the ventilator control system.

[0026] FIG. 14 is a functional block diagram of the simulator portion of the ventilator control system FIG. 15 is an illustration of a section of the display screening showing a waveform shaper.

[0027] FIG. 16 is an illustration of a therapy programming screen for the ventilator control system.

#### DETAILED DESCRIPTION

[0028] 1. Ventilator Control System-The invention features a ventilator control system for controlling a ventilator pneumatic system in a medical ventilator. The ventilator control system provides a clinician with complete control of a patient's airway flow and pressure throughout the respiratory cycle, and thereby enables the clinician to determine the optimal therapy for the patient. In order to decrease the work of exhalation in this situation, negative pressure can be applied to the exhalation circuit of the patient's ventilator to reduce the resistance to airflow.

[0029] Because resistance to airflow is an exponential function of flow, negative pressure must be adjusted to

compensate for resistance as increases and decreases in airflow and airway resistance occur. If too much negative pressure is applied to the conducting airways dynamic collapse of the conducting airways can occur and this may result in alveolar gas trapping. Varying the applied negative pressure according to airflow and airway resistance allows maximum assist to be applied during peak expiration, when resistance and work of breathing is greatest. By decreasing the applied negative pressure at lower airflow rates, airway collapse can be averted.

[0030] If airway pressure rises above the clinically indicated level of positive end-expiratory pressure (PEEP), the lung will be overpressurized thus the effective airway pressure throughout the expiratory cycle is titrated throughout the expiratory phase under precise algorithmic control. The clinical benefit of a certain PEEP level will be diminished. Thus, the effective airway pressure throughout the expiratory cycle must remain greater than zero and less than PEEP.

[0031] FIG. 1 is a block diagram of a ventilator including a ventilator control system 10 incorporating the features of the invention. The ventilator control system 10 includes a display controller 12 and an embedded controller 14. The display controller 12 provides an interface to the clinician 16, and the embedded controller 14 provides an interface with a ventilator 17 providing ventilation to a patient 20. The display controller 12 and the embedded controller 14 each include memory (not shown) and are electrically coupled via a shared memory interface 15. Data from the display controller 12 and the embedded controller 14 are stored in a database 13.

[0032] A sensor monitoring system 19, including an exhalation flowmeter 11 a circuit resistance sensor 9 and a pressure sensor 7 in communication with the airway 21, provide signals to an embedded controller 14 relating to airway pressure, flow and resistance. These measured values are stored in a database 13. These values are also compared with values preselected by a user by way of the embedded controller 14 to calculate the amount of negative pressure to be generated in the ventilator 17 in order to produce an airway pressure greater than zero and less than positive end-expiratory pressure. A pneumatic system 41 regulates the flow of gas delivered from the source of pressurized gas 45 through a Venturi valve within the ventilator 17 to produce this negative pressure. One embodiment of such a pneumatic system 41 is described in U.S. Pat. No. 5,664,563, owned by the assignee of the present invention, incorporated herein by reference. A pressure sensor 51 measures the amount of negative pressure produced within the ventilator 17 and transmits these data to the embedded controller 14. These data are stored in the database 13 and displayed on the display 24 of the display controller 12.

[0033] Initially, the clinician 16 enters target values into the system 10 by way of the input device 26 of the display controller 12. Each of these target values is compared with a corresponding current value of ventilatory unit pressure, airway pressure, airway flow and airway resistance by the embedded controller 14. Upon determining that there is a difference between current pressure, flow and resistance values and those values entered by the clinician 16, the embedded controller 14 generates a signal to the pneumatic system 41 so that the pneumatic system 41 changes the amount of negative pressure produced by the ventilator 17.

The ventilator 17 is in pneumatic communication with a flexible tubing 21 capable of attachment to a patient 20. The clinician 16 can also directly adjust the pneumatic system 41 by manipulating a plurality of controls on the input device 26 of the display controller 12.

[0034] The clinician 16 enters numerical data at the display controller 12 relating to the desired level of airway resistance in the flexible airway tubing 21 or relating to the desired amount of negative pressure in the pneumatic system 41. These entered values signal the pneumatic system 41 to change the amount of negative pressure on a per breath basis within the pneumatic system 41 until the pressure in the pneumatic system 41 or the resistance in the airway tubing 21 equals the value entered by the clinician 16.

[0035] The pneumatic system 41 controls gas flow and pressure in the patient's airway using a patient circuit. An electromechanical fresh gas flow control and measurement system provides a metered blend of oxygen and air via a heated, humidified gas delivery system. A high speed pneumatically driven, electronically controlled proportional valve and dual Venturi system provides bi-directional flow and pressure control as described in U.S. Pat. No. 5,664,563 incorporated herein by reference. Pressure 7 and flow 11 sensors provide feedback control of the desired breathing pattern and verify operation within safe limits. The pneumatic and electronic systems and patient circuit are described in extensive detail in commonly assigned patent application, Ser. No. 08/352,658, incorporated herein by reference.

[0036] The safe performance of the ventilator 10 is enhanced by the redundancy of the two independent display controller 22 and embedded controller 30 processors, which continually check each other's performance via the shared memory interface 15. The embedded controller 14 communicates its status, and that of the patient, to the display controller 12. The embedded controller 14 maintains a non-volatile record of the therapy control structure and continues to operate at the last known good settings if communication becomes lost. The two systems which comprise the ventilator control system 10 give both audible and visual messages when an alarm condition exists, and maintain an alarm history. The systems provide alarms and mandatory patient support upon detection of apnea (i.e., the detected absence of breathing). During operation, both systems perform background tests to detect system faults. The ventilator provides a series of reduced operation modes to provide life support if system capability is compromised.

[0037] In more detail, FIG. 2 is a block diagram of the display controller 12. The display controller 12 includes a processor 22, a display 24 and an input device 26. In one embodiment, the input device 26 is a touchscreen used in conjunction with the display 24. The processor 22 collects input information from the clinician 16, validates the input, creates a therapy control structure from the input information and sends the resulting structure to the embedded controller 14. The therapy control structure is a hierarchical arrangement of similar data structures which includes one or more mode control structures, one or more breath control structures, one or more phase control structures and one or more cycle control structures. Data generated and collected by the processor 22 are stored in the database 13. The display 24 maintains and displays the patient's history in a

graphical format which highlights the patient's status. In one embodiment, the display 24 is a CRT. In another embodiment, the display 24 is a flat panel display. More specifically, the display 24 provides a visual indication of the current breath control parameters, alarm and fault conditions, and the current status of the patient's pulmonary system, including gas pressure, flow and volume. In one embodiment, the touchscreen 26 covers the surface of the CRT display 24 and provides a straightforward, highly flexible means to change control settings.

[0038] The display controller 12 is a powerful graphics workstation with hardware and software components. In one embodiment, the clinician interacts with the display controller 12 via a color CRT monitor 24 and a touchscreen 26. The display 24 is modified to run from an isolated power supply, and the touchscreen power supply and controller are built in to the monitor. In one embodiment, the processor 22 is included in a single board computer which also includes RAM, an integrated high speed graphics driver, and an integrated dual port memory. The display controller 12 also includes a hard disk drive 23.

[0039] While the display controller 12 provides interpretation and decision support information on the display 24, the ventilator 17 does not change any breath control parameters unless directed by the clinician 16. Nevertheless, the display controller 12 provides a flexible user interface with multiple interactive levels, from simple text menus of controls for inexperienced users, to complete visual feedback for clinicians who understand the patient models and can intervene more aggressively and effectively.

[0040] In more detail, and referring also to FIG. 3 a block diagram of the embedded controller 14 is depicted. In one embodiment, the embedded controller 14 includes a system board 28, a real time data processor 30, a ventilator processor 32 and an airway processor 31. The real time processor 30 manages sensor data collection from the sensor monitoring system 19, processes measured data, performs alarm/fault detection and provides control data to the ventilator 17. The embedded controller 14 further receives data input by the clinician 16 and accesses with the database 13.

[0041] A first data processor 31, an airway processor, receives signals from the patient sensor monitoring system 19 relating to airway pressure, flow and resistance. A second data processor 32, a ventilatory unit processor, receives signals from the pressure sensor 51 in communication with the ventilatory pneumatic system 18. Signals from both data processors 31 and 32 are transmitted to a third data processor, a real time data processor 30. This data processor 30 calculates the amount of negative pressure that must be generated by the pneumatic system 41 to change the airway resistance to exhalation. This calculation is made by comparing the data relating to airway pressure, flow and resistance to preselected values and then calculating the change in ventilatory unit negative pressure required to affect the desired change in airway resistance.

[0042] In more detail, and referring also to FIG. 4, a block diagram of the ventilator 17 in communication with the flexible airway 21 that is the conduit for inhalation from the patient 20 is depicted. The pneumatic system 41 regulates the amount of negative pressure produced within a rigid chamber 43 by adjusting the flow of gas from a source of pressurized gas 45 through a Venturi valve 47. Within the

rigid chamber 43 is a flexible canister 49. Negative pressure produced within the rigid chamber 43 is transmitted to the flexible canister 49 and thus to the patient airway 21 which is in pneumatic communication with the flexible canister 49. In this way, negative pressure is applied to the patient airway 21 to assist the patient's exhalation through the canister 49 into the medical ventilator 7. Pressure within the flexible canister 49 is measured by a pressure sensor 51. These data are transmitted to the embedded controller 14.

[0043] Now referring also to FIG. 5 a detailed functional block diagram of the ventilator control system 10 is depicted. As shown, the clinician 16 manipulates a control setting slider 34 to change or set one or more breath parameters. A change alert panel 36 on the display 24 informs the clinician 16 of the process, from input to implementation, to assure him that his input information is being processed properly. As noted previously, a change to one or more breath parameters will lead to changes in one or more data structures of the therapy control structure hierarchy. It is noted that FIG. 5 provides an example of a breath parameter change which results in a change at the level of the breath control structure. The validation process includes the processor 22 validating 38 the clinician's inputs and creating 40 a breath control structure which is stored in memory. The display controller 12 transmits the breath control structure to the embedded controller 14 and informs the clinician 16 of successful transmission via the change alert panel 36. The embedded controller 14 initially stores 44 the breath control structure in local memory. The embedded controller 14 re-validates 46 the settings within the breath control structure. The embedded controller 14 implements 48 the validated breath control structure 48 using a breath control algorithm 50 and provides signals to the pneumatic system 41 for simultaneously changing one or more control settings at the appropriate time. This process enables the user to change or implement a new therapy so that the therapy delivered to the patient is essentially uninterrupted, and the new therapy is synchronized with the next inspiration. If, however, any step in the process is not completed, the clinician is alerted via the panel 36 to the cause of the error and the process is terminated.

[0044] The ventilator control system 10 provides two independent feedback paths to assure the clinician 16 that his setting change has been properly implemented. First, the embedded controller 14 calculates a series of breath monitoring values and sends them to the display controller 12, where the values are displayed 60 contiguous to the desired setting controls. The breath monitoring values can be, for example, set breath rate, measured breath rate, set tidal volume, measured inhaled volume, and measured exhaled volume. The display controller 12 also displays 60 a series of measurements (e.g., peak airway pressure, peak airway flow, and PEEP) from the waveform data both numerically and graphically. Second, the display controller 12 displays 54 the continuous waveforms on the display 24. The waveforms are derived 56 from raw data from the sensors 19, returned from the embedded controller 14 and passed directly to the display 24.

[0045] One feature of the ventilator control system 10 is that it can be configured to provide an assisted phase of a breath to the patient 20. As noted previously, the accumulated volume of gas inhaled by the patient as a result of his spontaneous respiratory muscle activity can be monitored.

To accomplish this, the sensor monitoring system 19 measures the flow of gas inhaled by the patient 20 at the beginning of the inspiration phase of the breath and integrates the flow to provide the measured volume. The embedded controller 14 compares the measured volume to a trigger volume set by the clinician 16, and adjusts the plurality of controls within the pneumatic system 41 when the measured accumulated volume exceeds the trigger volume to provide an assisted phase of a breath. The embedded controller 14 also may adjust the trigger volume dynamically according to measured patient flow and pressure signals indicating the phase of the respiratory cycle. In particular, the embedded controller 14 may increase the trigger volume set by the clinician 16 during periods of the breath where increases in the pressure at the airway of the patient 20 may be induced by changes in the pneumatic system 41, and not by spontaneous efforts of the patient.

[0046] Another feature of the ventilator control system is its ability to distinguish between active inspiratory effort and passive reverse airflow due to the elastic rebound of the chest wall and lungs. The present system is configured such that if the patient's spontaneous inspiratory efforts are being assisted, passive reverse airflow can not erroneously trigger an assisted breath. To accomplish this pressure and flow data provided by the sensor monitoring system 19 are analyzed by the embedded controller 14 to discriminate between passive airflow and active initiation of inspiration. Specifically, referring to FIG. 6 and 6a, the clinician sets the trigger volume needed to initiate a breath. The system 10 then determines the baseline pressure and flow for the patient.

[0047] As the patient exhales, the system 10 monitors both the patient airway flow and the patient airway pressure. Referring to FIG. 6, if the gas flow is seen to flow into the patient, and the pressure slope is positive, the flow into the patient is considered to be a result of overshoot and no inhalation is triggered (FIG. 6a). If the pressure decreases and the gas flow is into the patient (Step 300), then the total amount of gas inhaled by the patient is measured, and compared to the trigger volume (Step 310).

[0048] If the total amount of gas inhaled is greater than the trigger volume and this value has been reached in less than 200 msec, a breath is initiated. If the trigger volume has not been reached and it is taking more than 200 msec, the volume of inhaled gas is continued to be measured until the trigger volume has been reached (Steps 320, 330).

[0049] Another feature of the ventilator control system is its ability to compensate for gas flow resistance into and out of the lungs of the patient 20. Using the input device 26, the clinician 16 can set a resistance parameter of the patient's respiratory system to a selected value. Alternatively, the display controller 12 may calculate a value for the gas flow resistance from gas flow and pressure measurements provided by the sensor monitoring system 19. The gas flow resistance is described by the equation:

[0050] 
$$\text{Gas Flow Resistance} = (\text{Inspiration Peak Pressure} - \text{End Inspiration Plateau Pressure}) / (\text{Inspiration Flow at Peak}).$$

[0051] The selected or calculated resistance value is provided to the embedded controller 14 by the display controller 12. The embedded controller 14 adjusts one or more controls of the pneumatic system 41 to compensate for the

resistance to flow. The compensation for resistance to flow may be selected to occur during any one or more of the inspiration, exhalation or post-breath phases of a breath. Further, the controls may be adjusted to compensate for different selected or calculated resistance during different phases of a breath.

[0052] 2. Display Controller-The display controller **12** is an intelligent assistant for the clinician **16**. The display controller **12** quickly informs the clinician **16** of the effects of intervention, provides fast, graphical feedback, and presents information in a manner that requires minimal training to understand.

[0053] Referring also to **FIG. 7** an illustration of a display screen **64** provided by the display controller **12** is depicted. The display controller **12** uses software-generated waveforms and software-generated icons for control and alarms settings. The bottom row of touch sensitive on/off buttons **66** includes: a Power button that controls the ventilator control system; a Freeze button to pause the display; a Modes button to display various modes; a History button to play back a database of historical patient protocols; a 100% O<sub>2</sub> button to flush the ventilator with oxygen; Help and Save buttons; and an Others button to display other capabilities.

[0054] The left side of the screen includes a list of the publically available ventilator control settings. The top area displays the current mode of ventilation **67** (e.g., Backup). Below the current mode display, each row in the list has three columns. The left column is the current set value. If a row in the left column is inactive, it displays an OFF indication. Important current set values are highlighted. The middle column is a touch sensitive display showing the abbreviated title of the setting. The right column is the actual value of the setting as measured during the previous breath. If the actual value exceeds an alarm limit, the exceeded value turns red and a large alarm message is displayed on the screen. By touching a row, a control slider (not shown) appears on the right side of the screen. The control slider enables the clinician to change various parameters (e.g., alarm levels, control settings) and is described in detail below.

[0055] The middle area of the display screen is divided into top and bottom regions (**70, 72**). The bottom region **72** can include a variety of virtual instruments including: additional user-defined waveforms, trendlines, an events log, measured minute averages and other options. The top region **70** includes real time airway flow and pressure waveforms (**74, 76**), which are displayed over different shades of gray to indicated the breath phase. The airway flow waveform **74** illustrates flow into the patient, or inspiration (positive flow), and flow out of the patient, or exhalation (negative flow). The pressure waveform **76** illustrates that the patient's airway rises above ambient for inspiration and falls during exhalation. The waveforms are tracked by a cursor that can be programmed to follow a peak, average, plateau or manually set position. The waveforms are displayed in fixed axis, moving erase bar format. The time axis resolution is user adjustable and displays time in seconds. Overwriting of the display starts at the beginning of an inspiration, so that the first displayed breath starts at a fixed point on the screen. The vertical axes are scaled to keep the displayed waveforms and settings in clear view.

[0056] The right side **77** of the display screen normally includes a flow-volume loop **78**, a pressure-volume loop **80**

and a minute volume wheel **82**. A control slider and other optional panels can overlay this side when a user so desires. The flow-volume loop **78** is updated each breath to show the timing of delivered airflow. The vertical axis of the loop shares a common range and alignment with the airway flow waveform **74**. The pressure volume loop is updated each breath to show the condition of the lungs. The vertical axis of the loop shares a common range and alignment with the pressure waveform **76**. Calculated resistance and compliance are also displayed.

[0057] The minute volume wheel **82** provides a comprehensive summary of the patient's breathing for the last minute. The minute volume wheel displays a wealth of historical breath information (e.g., minute volume, inspiration phase, exhalation phase, inspiration/exhalation ratio, breathing rate, spontaneous minute volume, inhale tidal volume, exhale tidal volume, leakage) on a single integrated graphic circle so that the clinician can readily evaluate ventilation during the last minute.

[0058] Referring to **FIG. 8**, a minute volume wheel **84** represents one minute of ventilation as a circle with an area corresponding to measured minute volume. The measured minute volume is represented numerically, as the center number, and graphically, as a circle **86** drawn over a background circle **88** that has an area corresponding to the target minute volume. When the measured minute volume is exactly equal to the target minute volume, the two circles are blended in color and appear as one circle. When the measured volume is larger than the target volume, the background circle bleeds through and is visible. When the measured volume is smaller than the target volume, an uncovered portion of the background circle is visible.

[0059] One minute of ventilation is drawn as a circle **90**, one wedge at a time, and is redrawn once a minute. Like the face of a watch, each degree of the circle **90** corresponds to one sixth of a second. Each inspiration is drawn as a wedge **92** with an area corresponding to delivered volume. This wedge is drawn over an inspiration spoke **94** that extends to maximum minute volume. Each exhalation is drawn as a wedge **96** with an area corresponding to exhaled volume. This wedge is drawn over an exhalation spoke **98** that extends to maximum minute volume. The spokes indicate breathing regularity and inhale to exhale (I:E) time ratio, and the wedges indicate tidal volumes. Difference between the radius of inspiration and exhalation wedges indicates the I:E ratios. The I:E ratio and breathing rate are also represented numerically (**100, 102**). The pairs of inspiration and exhalation wedges are coded by color to indicate spontaneous breaths, those triggered and partially controlled by the patient, and mandatory breaths, those triggered and controlled by the ventilator. The ratio of the colored areas indicates the ratio of spontaneous to mandatory breathing during the minute just past.

[0060] Referring, again to **FIG. 7**, the display controller provides a method for clinician control of the displayed waveforms. Each waveform (**74, 76**) is continuously measured and displayed on a background that changes color to indicate the phase of a breath. The rectangular area **200** for any phase of the waveform (**74, 76**) is used as a target for the touchscreen. When the clinician selects a phase of a waveform, the display controller displays the associated ventilator controls for available for adjustment by the clinician.

[0061] The display controller provides cursors 201 which are actually floating windows. More specifically, windows of one or two pixels width float over the waveforms (74, 76), thereby creating cursors 201. Since the cursors are independent of the background waveform graphics, numerous advantages result including drawing optimization, dynamic repositioning based on changing waveform values, positioning based on user interface gestures.

[0062] The background of the waveform (74, 76) includes color shading to indicate breath phase, title, units and scale information. Redrawing these graphics as new waveform samples are displayed generally requires substantial computer time, and the display controller performs this function efficiently notwithstanding the complexity of the background image. To perform this task efficiently, background images are created once. A narrow rectangular region 202 is removed from these images and pasted in front of the moving waveform to clear out the previous waveform and refresh the background prior to the new waveform. The width of the rectangular area 202 is kept sufficiently small so that the refresh is smooth in appearance. The x-axis coordinate of the current waveform position is used to control the x-axis position from which to remove a strip of background image. Multiple color coded background images can be maintained (e.g., three gray shades for the breath phases) and images removed from the desired one depending on the state of the waveform.

[0063] By selecting one of the control buttons on the touch display, the clinician 16 can display the control slider 106 for the control setting in a fixed location at the right of the screen, as shown in FIG. 9. A scroll bar title 108, located near the top of the slider 106, indicates the name of the control setting. The full vertical range 108 indicates the allowed set limits. The center slider indicates the current position 110 and the range 112 of the control setting. The upper and lower sliders (114, 116) indicate the current alarm limit settings. The position 110 of the current setting within the allowable range 112 and within the alarm limits (114, 116) is readily apparent to the clinician. The clinician can move any of the sliders to change the set values in steps of approximately 1% of the allowable range, or with the "Exact" button selected, approximately ten times more precision (i.e., about 0.1% of the allowable range). When the desired value is reached, the clinician depresses the Accept Changes button to change the parameter.

[0064] Alarm settings are matched with control settings in the appropriate control sliders. Some control settings have two associated alarms, others have only one associated alarm or do not have any associated alarms. For example, both high and low inspiratory pressure alarms are provided on the Airway Pressure control slider. If an alarm limit is exceeded during operation, the alarm is displayed in an alarm window, and an audio alarm turns on. Alarms are non-latching, i.e., the alarm indication turns off when the detected level no longer violates the set limit. Available control settings and ranges, alarm settings and ranges, and measured parameters are listed in the following table:

Control Settings

Tidal Volume (Compliance Compensated)	50 to 2000 mL
Breathing Rate	2 to 150 bpm
Peak Inspiratory Flow (BTSP Compensated)	10 to 120 L/min

-continued

Oxygen Percentage	21 to 100%
Peak Inspiratory Pressure	2 to 120 cmH <sub>2</sub> O
Exhalation Assist	0 to 30 cmH <sub>2</sub> O/L/sec
PEEP	0 to 20 cmH <sub>2</sub> O
Inspiratory Time	0.2 to 4 sec
Inspiratory Pause Time	0 to 1 sec
Sensitivity (Patient Effort Trigger)	0 to 250 mL
Flow Drop-Off Percentage (Percent of Peak)	5% to 80%
<u>Humidifier Temperature</u>	<u>30 to 60° C.</u>
Airway Temperature	<u>15 to 40° C.</u>
Waveform Shape (clinician modifiable)	<u>custom, square decelerating, modified fine</u>
<u>Monitored and Displayed Parameters</u>	
Exhaled Tidal Volume (Compliance Compensated)	50 to 2500 mL
Measured Breathing Rate	2 to 150 bpm
Peak Inspiratory Flow (BTSP Compensated)	10 to 120 L/min
Oxygen Percentage	21 to 100%
Peak Inspiratory Pressure	0 to 120 cmH <sub>2</sub> O
PEEP	0 to 20 cmH <sub>2</sub> O
Mean Airway Pressure	0 to 120 cmH <sub>2</sub> O
Inspiratory Time	0.1 to 4 sec
Inspiratory:Expiratory Ratio	0.1 to 10.0
Minute Ventilation - Controlled	0 to 99 L/min
Minute Ventilation - Spontaneous	0 to 99 L/min
Airway Temperature	15 to 40° C.
Lung Compliance	10 to 150 mL/cmH <sub>2</sub> O
Airway Resistance	1 to 60 cmH <sub>2</sub> O/L/s
Leak	0 to 20 L/min
Airway Flow Waveform	-120 to +120 L/min
Airway Pressure Waveform	-20 to +60 cmH <sub>2</sub> O
Flow-Volume Graph, Pressure Volume Graph	see text
Fresh Gas Flow Bar Graph	see text
Minute Volume Wheel	see text
<u>Alarms and Indicators</u>	
High/Low Exhaled Tidal Volume Alarm	50 to 2000 mL
High/Low Respiratory Rate Alarm	2 to 150 bpm
Low Oxygen Fresh Gas Flow	Automatic, % O <sub>2</sub> dependent
Low Air Fresh Gas Flow	Automatic, % O <sub>2</sub> dependent
Low Oxygen Supply Pressure Alarm	25 psig
High/Low Airway Pressure Alarm	2 to 120 cmH <sub>2</sub> O
High/Low Inspiratory Time Alarm	0.2 to 4
High/Low Inspiratory:Expiratory Ratio Alarm	0.1 to 4.0
High/Low Minute Volume Alarm	1 to 40 L/min
Airway Leak Alarm	1 to 20 L/min
Patient Disconnect Alarm	Automatic
Apnea Alarm/Backup Ventilation	30
Internal Battery Notification Alarm	Battery in Use % Remaining
Pneumatic System Fault Alarm	Automatic
Alarms Silence	120
High/Low Oxygen Alarm	18-100% O <sub>2</sub>

[0065] In one embodiment, the display screen 24 is covered by a resistive touchscreen. Known touchscreen interfaces require that the user touch a graphic object on the screen, but this action generally obscures the object. The touchscreen interface of the present invention defines an area whose shape, size and position is dynamically computed based on the characteristics of the associated graphic object. The interface interprets touching by the user as a manipulation of the associated graphic object. More specifically, a dragging motion moves the associated object, or change its value or other attributes.

[0066] Referring again to FIG. 9, the display controller includes software for manipulating the characteristics of the breath parameter Airway Pressure 106 displayed in the control slider 104 on the touch-sensitive display 24. When the clinician 16 selects a control button to display the control slider 106 for Airway Pressure, the display controller 12 dynamically defines a touch zone on the touch-sensitive display. More specifically, touch zones are defined for each slider (i.e., high alarm, low alarm, position and allowable range) within the control slider. Each touch zone is slightly larger than the displayed slider. By way of example only, the touch zone for high alarm may extend into regions 118 to either side of the color coded high alarm region 114. The display controller 12 receives a touch signal when the clinician 16 touches any location within the touch zone and changes the range of the high alarm slider breath parameter in response to the touch signal. In other words, the display controller 12 increases the high alarm limit in response to the clinician 16 touching a location within the region 118 and dragging his finger in an upward path. Because his finger does not obscure the high alarm limit, the clinician can actually see the limit being change as it happens.

[0067] Referring also to FIG. 10, the display controller 12 includes software for providing precise numerical control without the requirement of a keyboard. The display controller 12 displays a window 120 that looks like a numeric text field, but has a background color to distinguish the left region 122 from the right region 124, relative to the decimal point. Once either numeric region 122, 124 has been touched, a larger touch sensitive area 126, 128 respectively is associated with each of the numeric regions. When the clinician 16 touches a touch sensitive area and moves in a vertical path, the interface provides continuous numeric feedback by increasing or decreasing the displayed value.

[0068] 3. Embedded Controller-Referring again to FIG. 1, the embedded controller electronics 14 is based around microprocessors 31, 32. The microprocessor 32 is in electrical communication with the ventilatory unit 17 and the microprocessor 31 is in electrical communication with the sensor monitoring system 19. The embedded controller relies on industry standard bus based modules to perform certain functions and custom printed circuit boards to perform other functions. The modules, the printed circuit boards, the ventilatory unit pressure processors 32 and the airway processor 31 are mounted on or connected to on a main printed circuit board 28. A real time operating system is the foundation of the embedded controller software, which runs the algorithms required for measurement and control. A power system converts line power and provides battery backup for a average of one hour.

[0069] The embedded controller 14 has microprocessor and associated input/output hardware to provide for closed loop control of pneumatic system 41 and the acquisition of patient data. The embedded controller 14 communicates the status of the patient and its own status to the display controller 12. The embedded controller 14 responds to commands and setting changes received from the display controller 12, and maintains a non-volatile record of instrument settings to maintain operation in the absence of both communication from the display controller and line power.

[0070] The embedded controller 14 performs real time data acquisition of twenty three different analog input signals including:

---

1. Flow	Oxygen,
2. Flow	Air,
3. Flow	Third Gas,
4. Flow	Canister,
5. Flow	Exhaust,
6. Pressure	Patient Airway,
7. Pressure	Canister,
8. Flow	Low Exhaust,
9. Temperature	Airway,
10. Temperature	Humidifier,
11. Voltage	Battery,
12. Current	5 Volts,
13. CO <sub>2</sub>	Airway,
14. Voltage	ECG,
15. Voltage	QRS,
16. Temperature	Patient Temperature 2,
17. Pressure	Patient Pressure 1,
18. Pressure	Patient Pressure 2,
19. Signal	PT34,
20. Voltage	Aux 1,
21. Voltage	Aux 2,
22. Voltage	Aux 3,
23. Voltage	Aux 4.

---

The embedded controller 14 also monitors six switches:

1. Pressure	Oxygen,
2. Pressure	Air,
3. Pressure	Third Gas,
4. Pressure	Safety Valve,
5. Voltage	Power Switch,
6. Voltage	No AC Line.

---

[0071]

The embedded controller controls nine digital outputs:

1. Solenoid	Exhaust Flow Zero,
2. Solenoid	Canister Flow Zero,
3. Solenoid	Safety Valve,
4. Solenoid	Direction (I/E),
5. Heater	Canister,
6. Heater	Fresh Gas Tube and Humidifier,
7. Power	CRT Display,
8. Alarm	Beeper,
9. Battery	Backup.

The embedded controller 14 controls four duty cycle modulated digital outputs:

1. Flow valve	Canister,
2. Flow valve	Air,
3. Flow valve	Oxygen,
4. Flow valve	Third Gas.

---

[0072] The embedded controller 14 communicates with the display controller 12. via a shared memory interface 15 at a data transmission rate exceeding 100K bytes per second.

[0073] 4. Data Structures-This section describes the architecture for software utilized in the embedded controller and shared with the display controller. The architecture of the software is built around the concepts of therapy controls, mode controls, breath controls, phase controls and cycle controls. A data structure driven state machine determines the control parameters for each therapy control, mode control, breath control, phase control, cycle control and exhalation assist.

[0074] Referring to FIGS. 1 and 11, the figures illustrate the data structure hierarchy for the ventilator control system. Using an input device 26 such as the touch-sensitive display 24 within the display controller 12, a clinician can change ventilation control settings to create a new therapy comprising a therapy control structure 140. The settings are validated by the display controller 12, placed into a new therapy control structure and sent to the embedded controller 14. The embedded controller 14 validates the settings again and checks the integrity of the new structure before the new therapy control is accepted. Also, the clinician 16 may simulate the behavior of the new therapy control using a simulator and may allow others to utilize the therapy control by adding it to the database 13. In any case, the clinician 16 sends the new therapy control structure to the memory for use by the embedded controller 14 in controlling the pneumatic system 41. A therapy control structure 142 (or a mode control) 140 is defined as a collection of mode control structures 142 and mode switching rules 144. A mode control structure (or a breath control) is defined as a collection of breath control structures 146 and breath switching rules 148. A breath control structure 146 (or a phase control) is defined as a collection of phase control structures 150 and phase switching rules 152. A phase control structure 150 (or a cycle control) is defined as a collection of ventilator control settings 154 and an array of waveform samples 156. Phase definitions and requirements for transitions between phases are tied directly to measurable system performance, and correlate closely to published descriptions of the desired behavior of mechanical ventilators.

[0075] More specifically, the therapy control structure 140 is a nested hierarchy of increasingly complex control structures. A cycle (e.g., a 4 msec time slice) occurs within cycle control, which occurs within phase control, which occurs within breath control, which occurs within mode control, which occurs within therapy control, which is the clinically specified therapy that drives the ventilator pneumatic system 41. Once each cycle, ventilation control moves from one control state to another control state.

[0076] After each cycle, when the hierarchy of rules is tested and the state is set for the next cycle, a new therapy control structure 140 may cause a branch to the first cycle of the first phase of the first breath of the first mode of ventilation within the new therapy control structure, or the new therapy control structure may be delayed a few cycles until better patient synchrony can be achieved. Within a therapy, there is a collection of mode control structures 142 and a collection of rules specifying how and when to switch from one mode of ventilation to another one. Thus, a therapy may define several different modes of ventilation and mode switching rules 144 for the transition from one mode of ventilation to another.

[0077] After each cycle, when the hierarchy of rules is tested and the state is set for the next cycle, the mode switching rules 144 may cause a branch to the first cycle of the first phase of the first breath of another mode of ventilation within the therapy control structure 140. Within a mode, which is within a therapy, there is a collection of breath control structures 146 and a collection of breath switching rules 148 specifying how and when to switch from one breath type to another breath type within the same mode. Thus, a mode of ventilation may have several different types of breaths defined, and rules specified for how to go from one breath type to another.

[0078] After each cycle, when the hierarchy of rules is tested and the state is set for the next cycle, the breath switching rules 148 may cause a branch to the first cycle of the first phase of another type of breath within the mode. Within a breath, within a mode, within a therapy there is a collection of phase control structures 150 and a collection of phase switching rules 152 specifying how and when to switch from one breath phase to another phase within the same breath. Thus, a breath type may have, several different phases defined, and rules specified for how to go from one breath phase to another. For example, breathing generally proceeds from an inspiration phase to a pause phase to an exhalation assist phase to a PEEP phase, but these phases may be further subdivided for a finer granularity of control.

[0079] After each cycle, when the hierarchy of rules is tested and the state is set for the next cycle, the phase switching rules 152 may cause a branch to the first cycle of the next phase within the breath type. Within a phase, within a breath, within a mode, within a therapy, there is a ventilator control setting structure 154. This structure contains an array of samples that comprise a specified waveform shape. During each cycle, the control logic is driven by the waveform sample specific for the cycle, and by a collection of ventilator control settings 154 specific for the phase. The cycle time is in milliseconds, and is currently set to four milliseconds.

[0080] After performing all ventilation control for the cycle, the hierarchy of rules is tested and the state is set for the next cycle, which is by default the next cycle within the current phase, current breath type, current mode of ventilation and current therapy. However, higher level rules may cause a change in breath phase, breath type, mode of ventilation, or an entirely new therapy may be specified by the clinician and take control at the next cycle.

[0081] Each ventilator control setting structure 158 contains necessary and sufficient information to control one parameter of ventilation, including whether there is a high alarm level, whether the high alarm is active, whether there is a control level, whether the control is active, whether there is a low alarm level, whether the low alarm is active, whether there is a range level, whether the range is active, and a range target control structure to define how and why the parameter is to be adjusted automatically within the specified range. Each phase control structure has its own collection of ventilator control settings, although in practice, phases within a breath generally share the same collection.

[0082] The data structure-driven architecture described above enhances safety and reduces the likelihood of hazardous conditions by permitting non-programmers to review and understand the function of the ventilator control system.

[0083] Several breath control structures are predefined in the embedded controller. These breath control structures are used when hazards are detected; such as apnea or patient circuit disconnect. They are also used to support the patient if the communication link between the display controller 12 and embedded controller 14 is lost. Also, the embedded controller 14 checks the integrity of every therapy control structure sent by the display controller 12. If a requested change is invalid, the embedded controller 14 continues operation with the last known valid therapy control structure. If no valid therapy control structure has been received, the embedded controller 14 uses the predefined breath control structures to continue patient support.



[0084] FIG. 12 is a flowchart of an embodiment of an algorithm executed by the exhalation assist device embodied in FIG. 1. The algorithm begins with the clinician 16 entering the desired values relating to airway resistance or negative pressure in the ventilatory unit (Step 1). These values are then compared with data relating to airway resistance or negative pressure in the ventilatory unit that have been measured or calculated by the data processing unit (Step 2). It is then determined whether these sets of data are equal to each other or are within a predetermined range of each other (Step 3). If these values are equal or within a predetermined range, airway flow is then measured (Step 5). If these values are not equal or within a predetermined range, the applied negative pressure is adjusted (Step 4), and then the airway flow is measured (Step 5). After airway flow is measured, it is determined whether the measured airway flow is a positive or a negative number (Step 6). If airway flow is positive, indicating that inspiration is occurring, a new measurement of airway flow is obtained (Step 5). If airway flow is negative, indicating that exhalation is occurring, airway pressure is measured (Step 7). It is then determined whether airway pressure is greater than zero and less than PEEP (Step 8). If airway pressure is greater than zero and less than PEEP, airway resistance is calculated and pressure in the ventilatory unit is measured (Step 9). After these measurements and calculations are made, the cycle recommences (Step 2). If airway pressure is not greater than zero and less than PEEP, it is determined whether the alarm has been overridden (Step 10). If the alarm has been overridden, airway flow is measured on the next breath (Step 5). If the alarm has not been overridden, the alarm is triggered (Step 11). If the alarm is triggered, the cycle must be restarted with the input of desired values (Step 1).

[0085] 5. Simulator-Referring again to FIG. 1, a simulator 212 is provided for predicting the status of the pulmonary system of a patient and a database 13 for storing actual or simulated historical patient protocols. The simulator 212 is electrically connected to the display and embedded controllers 12, 14 respectively. The simulator 212 uses a set of breath parameters provided by the clinician 16 via the input device 26 to predict the status of the patient's pulmonary system. The simulator 212 simulates the adjustment to the ventilator pneumatic system 41 in response to the set of breath parameters and the response of the patient's pulmonary system to the adjusted pneumatic system 41. The predicted status and the set of breath parameters are displayed on the display screen 24 (FIG. 13).

[0086] An advantage of the simulator 212 is that the clinician 16 can experiment with new or old settings, while the actual settings remain unchanged and the patient is unaffected. When the clinician 16 begins changing settings in the simulation mode, the ventilator control system 10 predicts the effects of the change and displays the predicted result on the display 24. The simulator 212 uses a standard two parameter model of a respiratory system and the current calculated values of the patient's resistance and compliance to predict the effect. The model assumes no contribution from the patient's respiratory muscles (i.e., a passive inspiration and exhalation cycle). The model used is:

$$\text{Airway Pressure} = (\text{Delivered Volume}/\text{Lung Compliance}) + (\text{Airway Flow} \times \text{Airway Resistance}).$$

[0087] A change in patient intervention in current ventilators typically requires multiple setting changes. Implementing such setting changes is greatly complicated by the series of indeterminate control states as one setting is changed at a time. Using the simulator 212, the clinician 16 can change multiple settings until the predicted waveforms are satisfactory and then activate all the changes simultaneously. If the clinician 16 is dissatisfied, he can quickly and conveniently return the control settings to their previous values without adversely affecting the patient.

[0088] The clinician 16 can also use the simulator 212 to select a mode of ventilation or sequence by modes, by choosing a programmed comprehensive therapy control structure. Those breath parameters, which are essential to the definition of the mode, are highlighted with a color-coded background. Other controls are listed as active or inactive. The explicit list of active controls clearly delineates the exact function of the mode and alleviates confusion caused by inconsistent or incomplete definitions. Moreover, the simulator 212 can precisely replicate the behavior of modes on preexisting ventilators. The clinician 16 can make adjustments to the list of controls to accurately simulate the ventilator that a hospital's staff has been trained to use. The list of controls together with the simulated behavior can help teach the effects of various modes on patients, rather than the ventilator-specific mode definition.

[0089] As claimed in FIG. 13, while the simulator 212 predicts the shape of the breaths using the two parameter model, and displays the simulation on the display 24, many other physiological models and predictions may be possible. Specifically, the simulator 212 may predict the effect of positive end expiratory pressure on lung volume and functional residual capacity; it may predict the effect of minute volume on blood oxygen and carbon dioxide levels; it may predict the effect of mean airway pressure on pulmonary blood flow; and it may provide other similar models.

[0090] Referring also to FIG. 1, the database 13 assists the clinician 16 in managing the intervention and in tracking patient status. The database 13 makes large amounts of stored patient data available at several levels of detail and encourages comparison of different patient data. The clinician 16 can compare stored historical patient data with current settings to learn whether the current intervention has been effective and whether the patient is progressing.

[0091] The database 13 is electrically coupled to the display controller processor 22 and stores a plurality of patient protocols. Each patient protocol includes at least a set of breath parameters and patient data. The breath parameter may be organized as one or more therapy control structures. The clinician 16 selects a patient protocol by depressing a touch zone on the display 24. The processor 22 copies the selected patient protocol into memory. In the operational mode, the processor 22 instructs the embedded controller 14 to simultaneously adjust the controls of the pneumatic system 18 using the selected patient protocol. In the simulation mode, the simulator 212 simulates the adjustment to the ventilator pneumatic system 41 and the resulting response of the patient's pulmonary system.

[0092] The processor 22 stores patient protocols as epochs, which are complete “snapshots” of a particular time or event. The processor 22 uses real time event and pattern discrimination to determine when to store epochs of interest. In this way, the clinician 16 does not have to decide a priori what may be important, what to “trend”, or how to process the data. Because all the data is stored, it can be post processed to reveal any aspect of the patient’s previous condition. The saved epochs are organized in the database. Access to the epochs can be by time, by event, or by area of interest. The ability to overlay data from previous epochs informs the clinician as to whether the patient is progressing, or whether the intervention is working as expected.

[0093] FIG. 14 is a detailed functional block diagram of the simulator feature of the ventilator control system 210. The clinician manipulates a control setting slider 216 to change or set a ventilator control setting. The clinician’s input are stored in a memory 218. The simulator 220 receives the inputs and creates a phase control structure, a breath control structure, a mode control structure, or a therapy control structure for use in its simulation. If, for example, the clinician 16 decides to use the breath control structure 222 to change the patient’s therapy, the selected breath control structure (which is embedded within a mode control structure within a therapy control structure) is transmitted to the embedded controller (at 224) via the shared memory interface. The embedded controller validates the settings within the breath control structure 226. The processor implements the validated therapy control structure 228, which includes the breath control structure, in a breath control algorithm 230 and provides signals 232 to the pneumatic system for simultaneously changing one or more control settings.

[0094] 7. Waveform Shaper-The waveform shaper shown in FIG. 15 is a graphical tool which enables a clinician to shape one or more phases of a breath. Characteristics such as the rise time and shape 130, the plateau length and shape 132, the fall time and shape 134 can be drawn to any desired characteristics by the clinician. In one embodiment, the phases can be shaped by touching the various active areas dynamically created on the touchscreen display displaying the waveform shaper and drawing the finger in the desired direction. In another embodiment, control buttons may be selected to add characteristics to the waveform, specifically sinusoidal or pulse-like variations about an average level during a phase. The waveform shaper is displayed by the display controller 12, wherein its output is used to fill the array of waveform samples 156 in the cycle control structure of the therapy control structure 140. The pneumatic system 41 in communication with the embedded controller 14 can in this way be directed to follow any arbitrary waveform “drawn” by the clinician for one or more phases of a breath.

[0095] 8. Interface Protocol-The patient data waveforms are driven by a data stream protocol. The data stream can be generated by sensors, which is the usual manner in which the ventilator operates, by the simulator 212 which uses the breath parameters and measured patient parameters to generate simulated sensor data, or by the stored sensor data in epochs to show historical patient behavior. The ability to use the same interface to display real data, simulated data and epoch data is an important feature of the ventilator control system.

[0096] 9. Integrated Control/Data/Alarm Display-Referring again to FIG. 7, patient data waveforms 74,76 presented on display screen 64 of the display controller 12 combine setting control, data and alarm displays in a single region. The association of numbers and graphic icons with the data waveforms provide context to illuminate the meaning of the numbers and icons without unnecessary data or unit labels. A light line 201 is apparent as peak flow or pressure; a heavy bar 204 is apparent as the peak pressure set level; a light bar 203 is apparent as a high pressure alarm setting; an active rectangular region 200 on the pressure waveform is apparent for setting the exhalation pressure level. Differences between desired and actual settings, and alarm margins are readily apparent. The simplicity of these representations can be contrasted to a typical list of controls, calculated data, and alarms, where each item on the list is in LABEL:VALUE:UNITS format and the integration and comparisons must be performed in the head of the clinician.

[0097] 10. Therapy Programming-Referring also to FIG. 16 is an illustration of a therapy programming screen 205 provided by the display controller 12. With this screen, the clinician 16 can create or modify one or many breath parameters to prescribe a new type of therapy for the patient. Changes made are reflected at one or more data structure levels in the therapy control structure created in the display controller 12. After validation, the new therapy control structure can be sent to the embedded controller 14 for immediate implementation, or saved to a list of therapy prescriptions for later use.

[0098] A therapy can thus be built from the simple to the complex. Breath parameters are selected and changed to modify and combine cycles to define a phase; to modify and combine phases to define a breath; to modify and combine breaths to define a mode; and to modify and combine modes to define a therapy program. The selections are reflected in the hierarchy of structures in the therapy control structure, as previously described. The collection of settings are given a title by the clinician, in common use loosely defined as a mode of ventilation. The creation process, with its explicit connection of breath parameters to a mode definition, helps clarify the way the therapy will affect the patient. In contrast, modes preset by the manufacturer often have implicit, obscure and contradictory affects on the patient.

[0099] In one embodiment, the therapy programming screen 205 enables selection and changing of related breath parameters. The therapy prescription to be altered is selected from a list; a new therapy prescription can be created by selecting a similar prescription from the list, giving it a new title, and altering it as needed. A mode within the selected therapy prescription is selected; a breath within the selected mode is selected; a breath parameter control setting within the selected breath is selected; a sequence which identifies a specific, hierarchically nested breath parameter. Features of the breath parameter are toggled on or off, or chosen from lists which are brought forth when there are more than two choices. Every breath parameter, within each breath, within each mode, must be programmed to complete the therapy prescription.

[0100] Referring to FIG. 16, a control definition section 207 is displayed adjacent to the control slider previously described. The control definition section 207 includes a title 209 of the therapy prescription. The title in this example

includes two modes, and the mode (A/C pc) to which the selected breath parameter is tied is highlighted. The control setting for the breath parameter may have a range feature enabled **211**, which, if enabled, will bring forth a panel of selected targets appropriate for the range, and which, if enabled, means that the ventilator control system will seek to accomplish a range target goal **213** by varying the control setting within the range specified in the control slider. The control setting may be required to be on **215**, meaning that it cannot be turned off by the clinician when operating within this breath type within this mode. It may be required to be off **217**, meaning that it cannot be turned on by the clinician when operating within this breath type within this mode.

**[0101]** The therapy programming screen allows the control setting to be shared by one or more other breath types **219** within the mode, or within the paired modes, such that any adjustments to the control setting will affect all such breaths. It allows control settings to be highlighted **221** as having primary importance to clinicians making adjustments to therapy. It allows multiple breath types to be defined, and provides a selection of rules that will be tested to determine which breath type to use within the mode.

**[0102]** The embodiment allows the clinician to select from a number of triggers which determine the transition between modes of ventilation **223**, when a multi-mode feature is enabled **225**. The triggers for transition may be different depending on the direction of the transition. For the example shown, the trigger for the transition from variable pressure support (VPS) to assist control (A/C pc) is minute volume (MV), while the trigger for the transition from assist control to variable pressure support is sensitivity (Sense, i.e. patient effort).

**[0103]** While the particular embodiment permits the programming of two modes, due to conceptual limitations for this new capability on the part of clinicians, another embodiment includes therapy prescriptions which encompass many modes, with multiple triggers for the transitions between modes. Specifically, other prescriptions include sequences of modes which automatically change the treatment of a patient as his condition changes, and allow the clinician to readily control the sequence. Other prescriptions permit time limited modes, which turn on for a period and then revert to the mode, or combinations of modes, in effect prior to their turn on. The therapy programming screen enables the clinician to tune the therapy to the specific and ever changing needs of the patient, with much more power and flexibility than selecting from a set of simple ventilator modes preset by the manufacturer.

**[0104]** Equivalents

**[0105]** While the invention has been particularly shown and described with reference to specific embodiments, it should be understood by those skilled in the art that various changes in form and detail may be made therein without departing from the spirit and scope of the invention as defined by the appended claims.

1. A method of compensating for the gas flow resistance in a ventilatory apparatus, the method comprising the steps of:

- determining the peak exhalation flow rate;
- determining the airway resistance;

calculating the effective airway pressure; and

applying a negative airway pressure to an exhalation circuit such that the effective circuit pressure is greater than zero and less than PEEP.

2. A method of claim 1, further comprising adjusting the amount of negative pressure to generate a predetermined effective circuit pressure with a measured value between zero and PEEP.

3. A method of claim 1 further comprising measuring an exhaled tidal volume and adjusting the amount of applied negative airway pressure such that the effective pressure in the exhalation circuit remains constant.

4. A method of claim 3 wherein the steps of measuring the exhaled tidal volume and adjusting the amount of applied negative pressure comprise the steps of:

determining the effective airway pressure and the air flow in the exhalation circuit;

determining instantaneous changes in pressure and flow;

sensing the initiation of an active breathing cycle by comparing said instantaneous changes with predetermined parameters; and

storing these data in a database.

5. A ventilator assist device comprising:

a reservoir for inhaled and exhaled gas in communication with a breathing apparatus adapted for attachment to a patient;

a source of negative pressure in communication with said reservoir;

a data processing unit in electrical communication with said negative pressure source and also in electrical communication with an exhalation flowmeter and a circuit resistance sensor;

said exhalation flowmeter and said circuit resistance sensor in communication with said breathing apparatus;

and a user interface in electrical communication with said negative pressure source allowing direct setting of a value for desired negative airway pressure by a user.

6. The ventilator assist device of claim 5 further comprising:

a flexible canister attached to gas inflow and outflow circuits of a ventilator in pneumatic communication with the exhalation circuit adapted for connection to the patient being ventilated;

an airtight housing surrounding the canister;

a Venturi valve in pneumatic communication with said housing and in pneumatic communication with an external source of pressurized gas;

a controlling processor in electrical communication with the Venturi valve, said controlling processor controlling the flow of said pressurized gas;

a pressure sensor in electrical communication with said controlling processor and in pneumatic communication with said housing;

a control panel in electrical communication with said controlling processor, said control panel allowing direct input of a value for desired negative pressure by the user;

the exhalation flowmeter in electrical communication with said controlling processor, said exhalation flowmeter in pneumatic communication with the airway tubing capable of attachment to a patient and also in electrical communication with the control panel;

the circuit resistance sensor in electrical communication with said controlling processor and said control panel, said circuit resistance sensor in communication with said airway tubing;

wherein said controlling processor adjusts the flow through the Venturi apparatus in response to the flow and resistance determined by said exhalation flowmeter and said circuit resistance sensor to yield a negative pressure around said canister such that a pressure is generated in said airway tubing that is greater than zero and less than PEEP.

**7.** The controlling processor of claim 6 further comprising:

a first data processor in electrical communication with said exhalation flowmeter and said circuit resistance sensor;

a second data processor in electrical communication with said pressure sensor;

a third data processor that compares input data with predetermined values and calculates the amount of negative pressure to be applied to generate a pressure in said airway tubing greater than zero and less than PEEP;

said third data processor further calculating from the data input from said exhalation flowmeter and said circuit resistance sensor instantaneous values for pressure, flow and resistance in the airway tubing capable of attachment to the patient;

a gas flow controller in electrical communication with said third data processor and in communication with

the Venturi valve, said gas flow controller regulating the flow through said Venturi valve in response to data parameters as processed by said third processor;

the database in electrical communication with said first, second and third data processors, wherein said database is adapted for storing data processed by said first, second and third data processors.

**8.** The user interface of claim 5 further comprising:

a display screen and the control panel, whereby said display screen provides graphic representation of said data parameters contained in the database, and whereby additional values can be entered by the user using said control panel;

said control panel further comprising a plurality of controls;

said plurality of controls in electrical communication with the gas flow controller; and

said user interface in electrical communication with the database, with the third data processor and with the gas flow controller.

**9.** The controlling processor of claim 6 further comprising:

an alarm system in electrical communication with the third data processor and with the user interface that is triggered by a level of pressure in said airway tubing less than zero or greater than PEEP; and

an override device in electrical communication with said alarm system and with said user interface that discontinues the alarm signal in response to a command input by the user.

**10.** The controlling processor of claim 7 wherein said first, second and third data processors are independent.

\* \* \* \* \*