



US 20130014408A1

(19) **United States**

(12) **Patent Application Publication**
Neilson

(10) **Pub. No.: US 2013/0014408 A1**

(43) **Pub. Date: Jan. 17, 2013**

(54) **DECORATIVE COVER FOR A SHOE**

Publication Classification

(75) Inventor: **Julie Neilson**, Winchelsea (AU)

(51) **Int. Cl.**
A43B 3/24 (2006.01)

(73) Assignee: **SHINE ENTERPRISES AUSTRALIA PTY LTD**, Winchelsea (AU)

A43D 11/00 (2006.01)

(52) **U.S. Cl.** **36/101; 12/142 R**

(21) Appl. No.: **13/509,558**

(57) **ABSTRACT**

(22) PCT Filed: **Nov. 15, 2010**

(86) PCT No.: **PCT/AU2010/001528**

§ 371 (c)(1),

(2), (4) Date: **Sep. 25, 2012**

(30) **Foreign Application Priority Data**

Nov. 13, 2009 (AU) 2009905534

A decorative cover (10) for a shoe (12), including a toe section (14) and a heel section (16) separated by a bridging section (18), wherein the cover (10) is at least partially resiliently expandable so that the toe section (14) and the heel section (16) resiliently bear against respective heel and toe sections of the shoe when the cover is fitted over the shoe, wherein the cover includes an upper boot section (32) shaped for engagement with a leg of a person wearing the shoe.

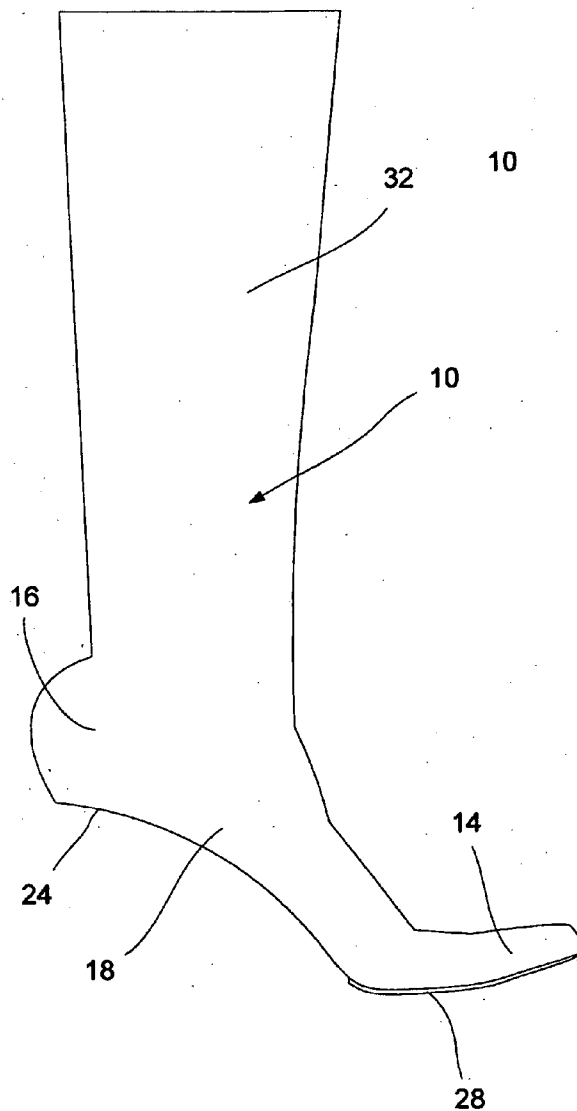

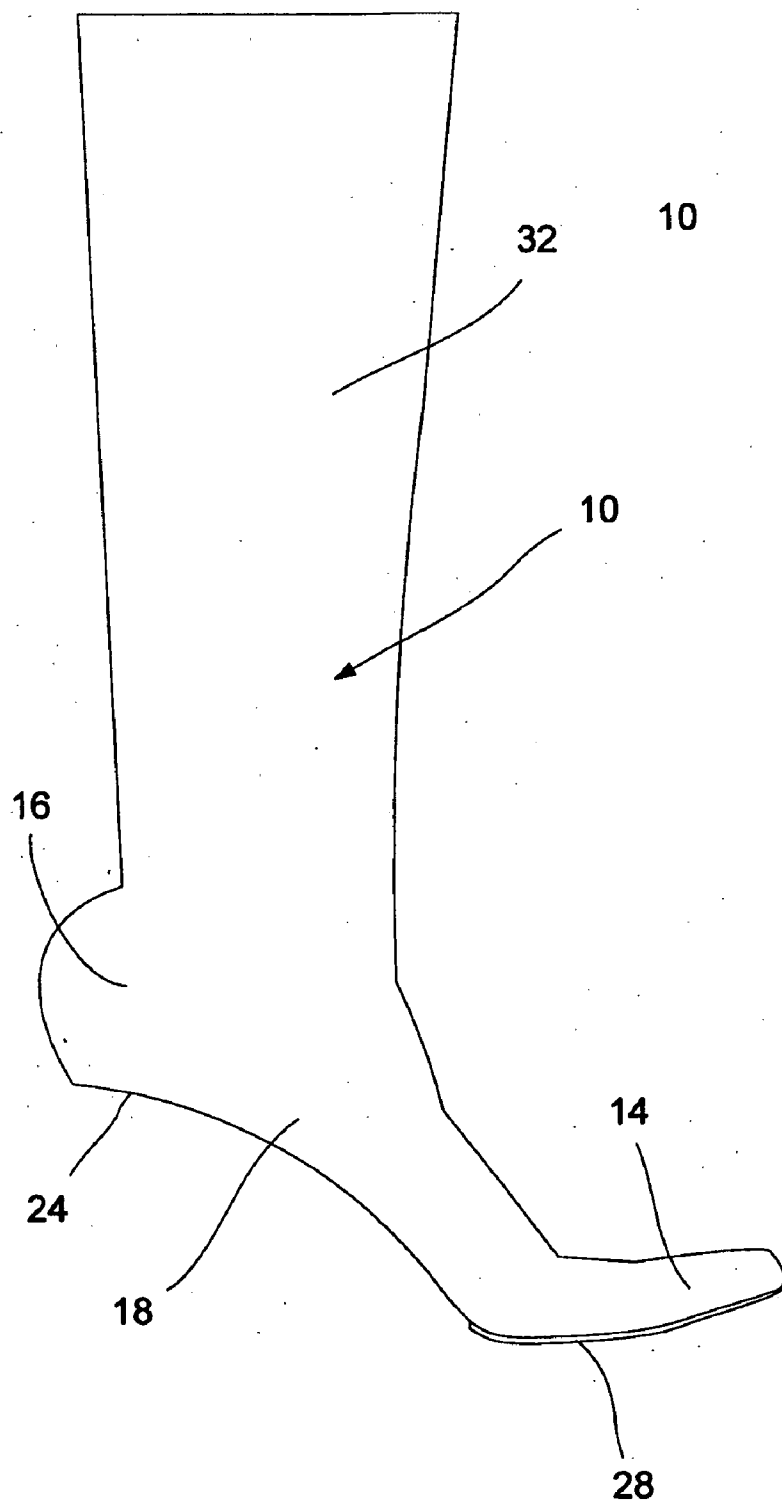

Figure 1

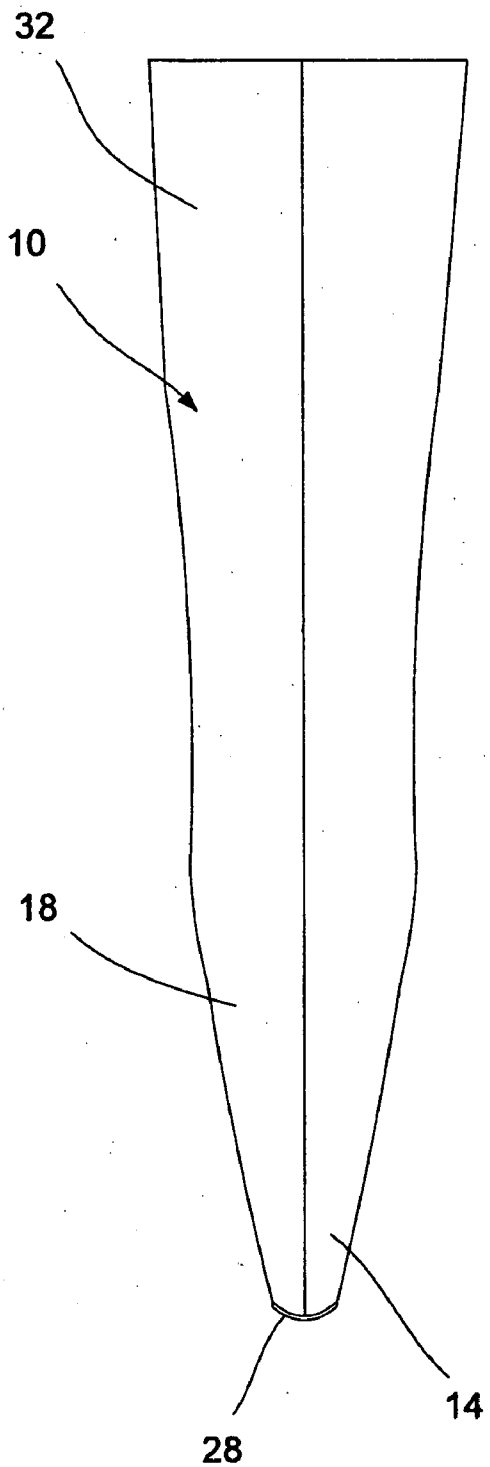

Figure 2

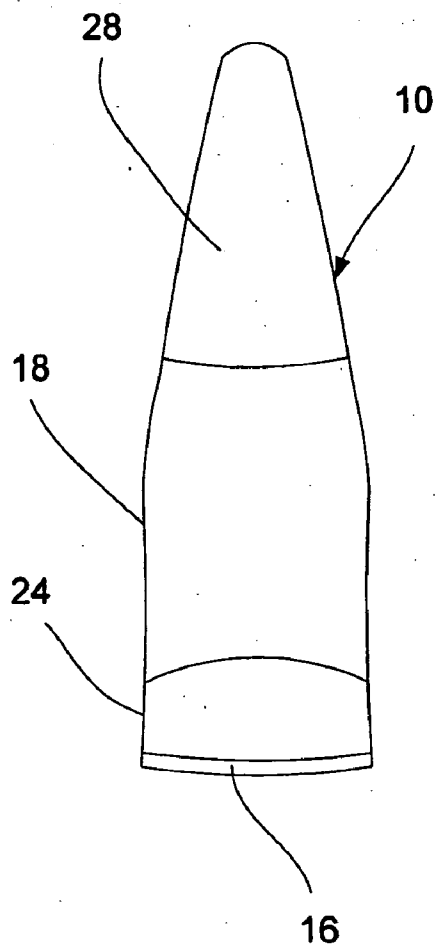

Figure 3

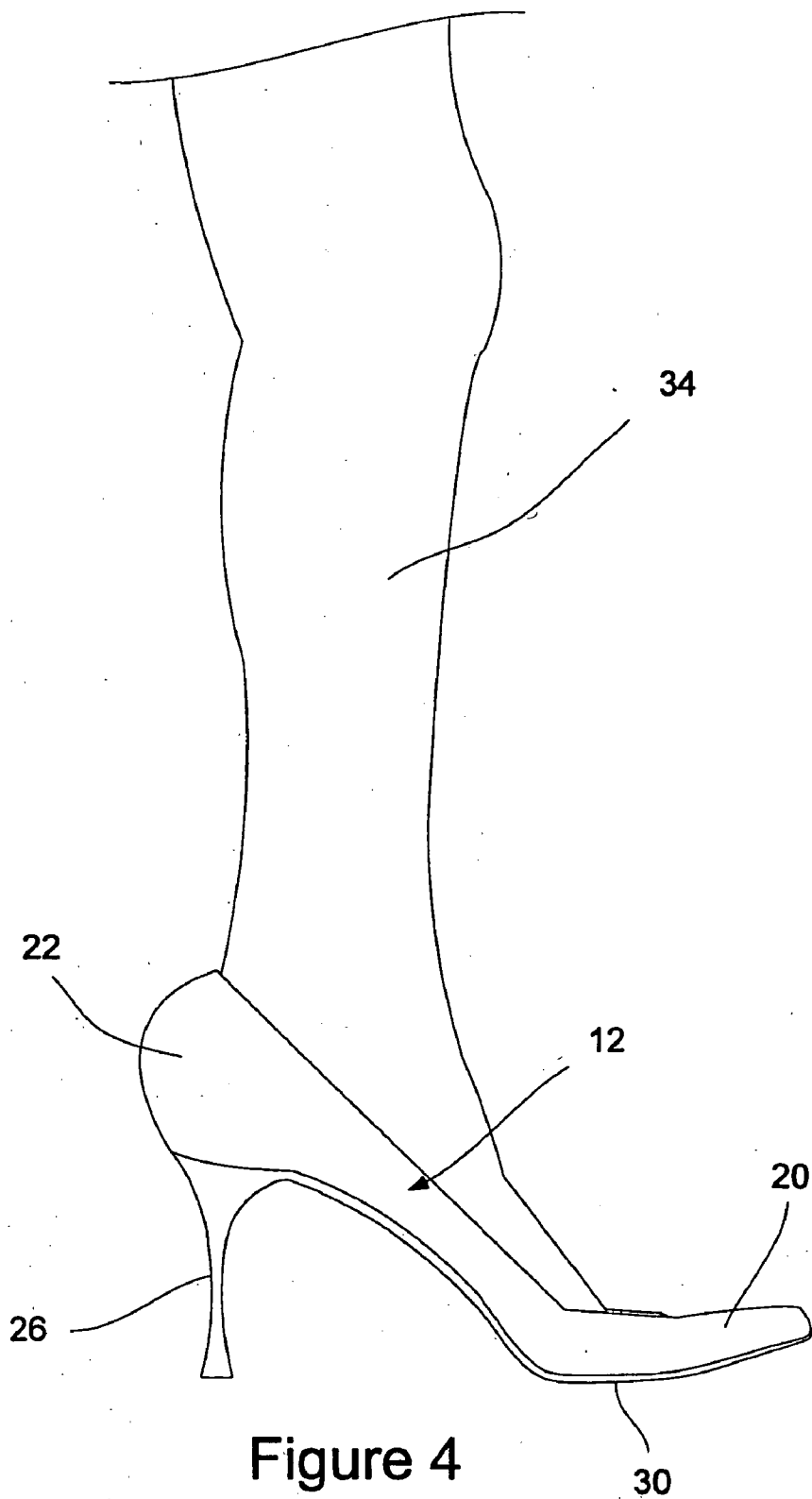

Figure 4
(prior art)

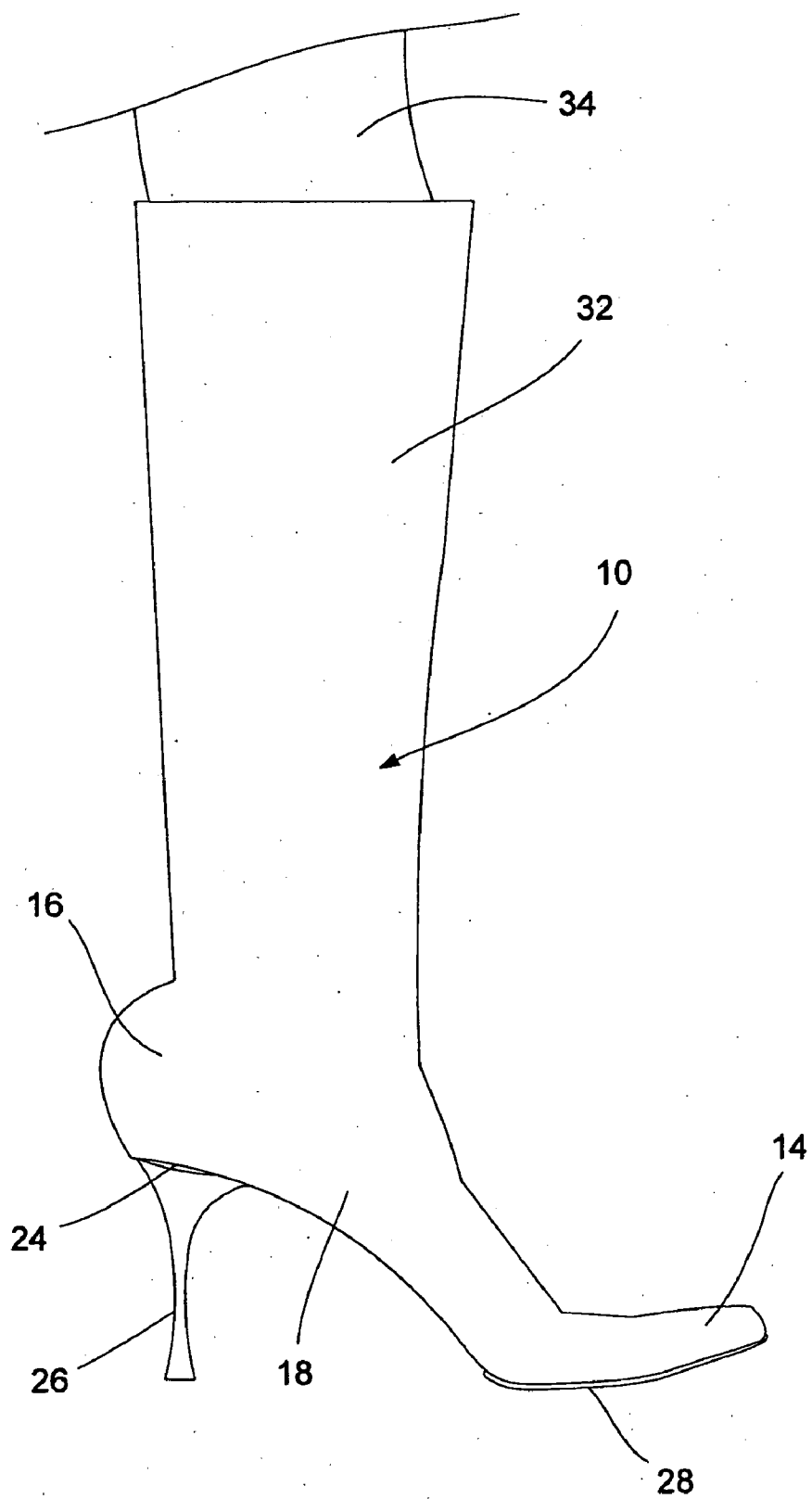

Figure 5

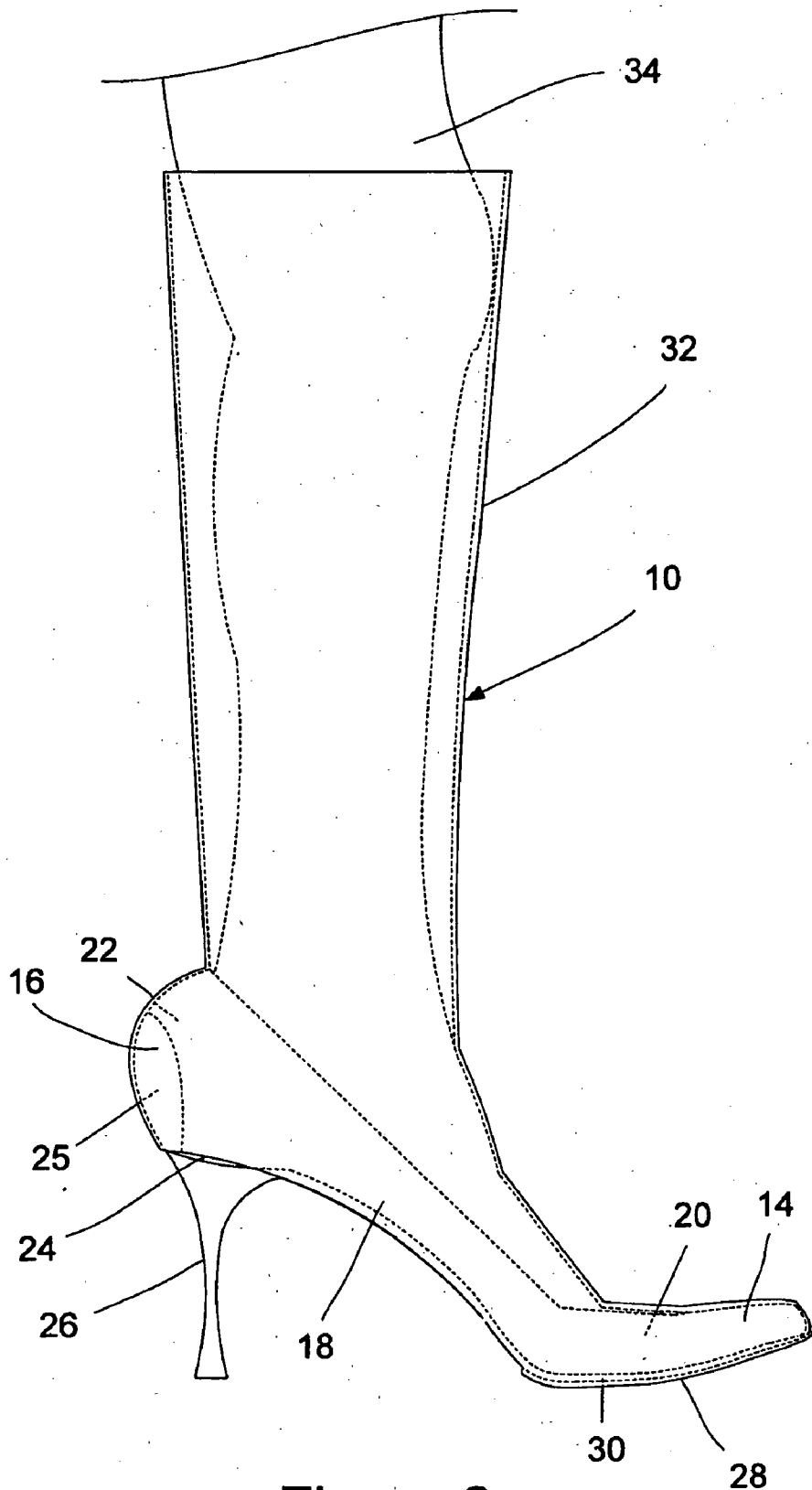

Figure 6

DECORATIVE COVER FOR A SHOE

FIELD OF THE INVENTION

[0001] The present invention relates to a decorative cover for a shoe. The present invention also relates to a method of fitting a decorative cover to a shoe.

BACKGROUND OF THE INVENTION

[0002] A woman, for example, may purchase a new pair of shoes to match a particular clothing ensemble. The shoes will typically be chosen to match a particular dress, skirt, jacket, or pair of pants. Notwithstanding that this process may result in a well coordinated clothing ensemble, use of the new pair of shoes may be limited to the particular D ensemble for which they were purchased. As such, the shoes may be forced into early retirement when the woman tires of the ensemble.

[0003] A lucky pair of shoes may have an extended life if the shoes can be used with multiple clothing ensembles. In such cases,, the life expectancy of the shoes may be. slightly extended. However, the woman will still likely have multiple pairs of shoes, one for each set of matching clothing ensembles.

[0004] Purchasing different pairs of shoes to match different clothing ensembles is a time consuming and expensive process.

[0005] A woman may wear a particular heel height to suit the occasion, e.g. work, medium size heel and when the occasion arises to add some glamour the shoe maybe exchanged with a similar pair with higher heels.

[0006] It is generally desirable to overcome or ameliorate one or more of the above mentioned difficulties, or at least provide a useful alternative.

SUMMARY OF THE INVENTION

[0007] In accordance with one aspect of the invention, there is provided a decorative cover for a shoe, including a toe section and a heel section separated by a bridging section, wherein the cover is at least partially resiliently expandable so that the toe section and the heel section resiliently bear against respective heel and toe sections of the shoe when the cover is fitted over the shoe. The cover includes an upper boot section shaped for engagement with a leg of a person wearing the shoe.

[0008] Preferably, the heel section includes an aperture shaped to receive a heel of the shoe.

[0009] Preferably, the toe section and the heel section at least partially conform to the shape of respective toe and heel sections of the shoe when the cover is fitted to the shoe. Alternatively, for sling back or open back shoes, the wearer may pull the heel section of the cover upwards, such that the cover sits above the heel exposing the wearer's bare heel.

[0010] The cover preferably includes a sole section shaped to at least partially engage a sole of the shoe. The upper boot section preferably at least partially resiliently expandable so as to resiliently bear against the leg of the person.

[0011] In accordance with another aspect of the invention, there is provided a method of fitting the above described cover to a shoe, including the steps of:

[0012] (a) inserting the toe section of the shoe into a corresponding toe section of the cover;

[0013] (b) resiliently expanding the bridging section of the cover so that the heel section of the cover overlies the heel section of the shoe; and

[0014] (c) pulling the upper section of the cover up the leg of the person to the desired height.

BRIEF DESCRIPTION OF THE DRAWINGS

[0015] Preferred embodiments of the present invention are hereafter described, by way of non-limiting example only, with reference to the accompanying drawings in which:

[0016] FIG. 1 is a side view of a cover for a shoe;

[0017] FIG. 2 is a front view of the cover shown in FIG. 1;

[0018] FIG. 3 is a bottom view of the cover shown in FIG. 1;

[0019] FIG. 4 is a side view of a prior art shoe fitted to a foot of a person;

[0020] FIG. 5 is side view of the cover shown in FIG. 1 fitted to a shoe being worn by a person; and

[0021] FIG. 6 is a side view of the cover shown in FIG. 5 showing internal features in broken lines.

DETAILED DESCRIPTION OF THE EMBODIMENTS

[0022] The decorative cover 10 shown in FIGS. 1 to 3 is used to change the look of a shoe, sandal or boot 12 to match a particular clothing ensemble. For example, the look of the shoe 12 shown in FIG. 4 can be changed by fitting the cover 10 to the shoe in the manner shown in FIGS. 5 and 6. In doing so, the life expectancy of a pair of shoes can, advantageously, be extended. The shoe will also be protected from fabric scuffs and spills whilst wearing the, cover. Covers can be laundered (dry cleaned or hand washed).

[0023] The cover 10 is hereafter described by way of reference to the heeled ladies shoe 12 shown in FIG. 4. However, the cover 10 can be used with either an open or a closed toe shoe 12. Further, the cover 10 can be used with either an open or a closed back shoe 12.

[0024] The cover 10 includes a toe section 14 and a heel section 16 separated by a bridging section 18. The cover 10 is at least partially resiliently expandable so that the toe section 14 and the heel section 16 resiliently bear against respective heel and toe sections 20, 22 of the shoe 12 when the cover is fitted over the shoe 12. The toe section 14 and the heel section 16 at least partially conform to the shape of respective toe and heel sections 20, 22 of the shoe 12 when the cover 10 is fitted. The cover 10, when fitted, generally conforms 30 to the shape of the shoe 12.

[0025] The heel section 18 of the cover 10 includes an aperture 24 shaped to receive a heel 26 of the shoe 12. The heel 26 of the shoe 12 extends through the aperture 24 when the cover is fitted to the shoe 12 so that the heel engages a floor or ground surface (not shown). Consequently, the heel section 16 of the cover 10 is raised above the floor or ground surface. The heel section may also include a heel insert 25 arranged to frictionally engage the heel section 22 of the shoe 12 in manner shown in FIG. 6. The heel insert 25 inhibits unintentional movement between the heel section 18 of the cover 10 and the heel section 22 of the shoe 12. In an alternative embodiment not shown, for sling back or open back shoes, the wearer may pull the heel section 22 upwards, such that the cover .10 sits above the wearer's heel, exposing the wearers bare heel. An accessory, such as a clip, could be added to the centre front cover securing the cover to expose the wearer's bare heel.

[0026] The cover also includes a sole section 28 shaped to at least partially engage a sole 30 of the shoe 12. The sole

section 28 is adapted to frictionally engage both the sole 30 of the shoe 12 and the floor or ground surface. The sole section 28 is preferably made of rubber. The sole section 28 preferably provides a non-slip interface between the shoe and the floor or ground surface. The sole section 28 is preferably glued to the toe section 14 and the bridging section 18.

[0027] The cover 10 is preferably shaped to provide an alternative covering for any shoe or boot.

[0028] The cover 10 additionally includes an upper boot section 32 which converts a low cut dress shoe, sandal or boot 12 into a long boot. The upper boot section 32 is generally tubular and shaped for engagement with a leg 34 of a person wearing the shoe 12. The upper boot section 32 at least partially resiliently expandable so 30 as to resiliently bear against the leg 34 of the person, making the cover multi-sized to suit, a broad range of calf sizes. The upper boot section 32 can be arranged to extend different lengths along the leg 34 of the person. As such, the height of the boot can be adjusted to suit the desired look. The cover 10 preferably includes a zip (not shown) or lacing in a non stretch fabric such as leather or sheep skin extending along the upper boot section 32 from the heel section 16. The upper boot section 32 is preferably lined.

[0029] The cover 10 is fitted to the shoe 12 by performing the following steps:

[0030] (a) inserting the toe section 20 of the shoe 12 into a corresponding toe section 14 of the cover 10;

[0031] (b) resiliently expanding the bridging section 18 of the cover 10 so that the heel section 16 of the cover 10 overlies heel section 22 of the shoe 12; and

[0032] (c) pulling the upper section 32 of the cover 10 up the leg 34 of the person to the desired height.

[0033] The cover 10 is preferably made of an at least partially resiliently expandable material. Alternatively, the cover 10 is made of leather. The cover 10 is preferably made of a water proof material, also protecting from spills and scuffs; in sheepskin, leather or vinyl and like fabric, a zip or eyelets will be required.

[0034] The reference to any prior art in this specification is not, and should not be taken as, an acknowledgment or any form of suggestion that the prior art forms part of the common general knowledge in Australia.

[0035] It will be understood that the invention disclosed and defined in this specification extends to all alternative combinations of two or more of the individual features mentioned or evident from the text or drawings. All of these different combinations constitute various alternative aspects of the invention.

LIST OF PARTS

- [0036] 10 Cover for a shoe
- [0037] 12 Shoe
- [0038] 14 Toe section of cover
- [0039] 16 Heel section of cover
- [0040] 18 Bridging section of cover
- [0041] 20 Toe section of shoe
- [0042] 22 Heel section of shoe
- [0043] 24 Aperture for heel of the shoe
- [0044] 26 Heel of shoe

- [0045] 28 Sole section of cover
- [0046] 30 Sole of shoe
- [0047] 32 Upper section of cover
- [0048] 34 Leg of a person

1. A decorative cover for a shoe, including a toe section and a heel section separated by a bridging section, wherein the cover is at least partially resiliently expandable so that the toe section and the heel section resiliently bear against respective heel and toe sections of the shoe when the cover is fitted over the shoe;

wherein the cover includes an upper boot section shaped for engagement with a leg of a person wearing the shoe.

2. The decorative cover claimed in claim 1, wherein the upper boot section is at least partially resiliently expandable so as to resiliently bear against the leg of the person.

3. The decorative cover claimed in claim 1, wherein the toe section and the heel section at least partially conform to the shape of respective toe and heel sections of the shoe when the cover is fitted to the shoe.

4. The decorative cover claimed in claim 1, wherein the heel section includes an aperture shaped to receive a heel of the shoe.

5. The decorative cover claimed in claim 1, including a sole section shaped to at least partially engage a sole of the shoe.

6. The decorative cover claimed in claim 5, wherein the sole section of the cover is adapted to frictionally engage the sole of the shoe.

7. The decorative cover claimed in claim 1, wherein the upper boot section can be arranged to extend different lengths along the leg of the person.

8. The decorative cover claimed in claim, including a zipper extending along the upper boot section from the heel section.

9. The decorative cover claimed in claim 1, wherein the upper boot section is lined.

10. The decorative cover claimed in claim 1, wherein the cover is adapted to fit a shoe that is either open or closed toe.

11. The decorative cover claimed in claim 1, wherein the cover is adapted to fit a shoe that is either open or closed back.

12. A method of fitting a decorative cover to a shoe, the decorative cover being for a shoe, and including a toe section and a heel section separated by a bridging section, wherein the cover is at least partially resiliently expandable so that the toe section and the heel section resiliently bear against respective heel and toe sections of the shoe when the cover is fitted over the shoe;

wherein the cover includes an upper boot section shaped for engagement with a leg of a person wearing the shoe; and the method including the steps of:

(a) inserting the toe section of the shoe into a corresponding toe section of the cover;

(b) resiliently expanding the bridging section of the cover so that the heel section of the cover overlies the heel section of the shoe; and

(c) pulling the upper section of the cover up the leg of the person to the desired height.

* * * * *