

(43) Date of A Publication 24.05.1995

(21) Application No 9323402.9

(22) Date of Filing 12.11.1993

(71) Applicant(s)
Sharp Kabushiki Kaisha
(Incorporated in Japan)

22-22 Nagaike-cho, Abeno-ku, Osaka-shi, Osaka 545,
Japan

(72) Inventor(s)
Graham John Woodgate
David Ezra
Jonathan Harrold
Basil Omar

(74) Agent and/or Address for Service
Marks & Clerk
Alpha Tower, Suffolk Street Queensway,
BIRMINGHAM, B1 1TT, United Kingdom

(51) INT CL⁶
G02B 27/22

(52) UK CL (Edition N)
G2J JB7P

(56) Documents Cited
GB 0851404 A EP 0309630 A1 WO 88/08146 A1
US 5122650 A US 4756601 A US 4469415 A
US 3674339 A

(58) Field of Search
UK CL (Edition M) G2J JB7P JX15
INT CL⁵ G02B 27/22

(54) Three-dimensional projection display apparatus

(57) A 3D projection display comprises an autostereoscopic image producing means 22 - 27 which directs light beams corresponding to respective 2D views in different directions towards a projection lens 28 which co-operates with the image producing means to image the light beams at respective different regions 30 in the aperture of the projection lens. A light-transmissive or reflective screen cooperates with the image producing means and the projection lens to image the views at the screen. The screen may comprise a Fresnel lens 29 for where a magnified image of increased angular spread is required, a double lenticular screen angular amplifier (33, Fig. 5). The image producing means may comprise one or more illuminated LCD spatial light modulators whose images are combined by a beam splitter 21 or are temporally multiplexed (Fig. 7).

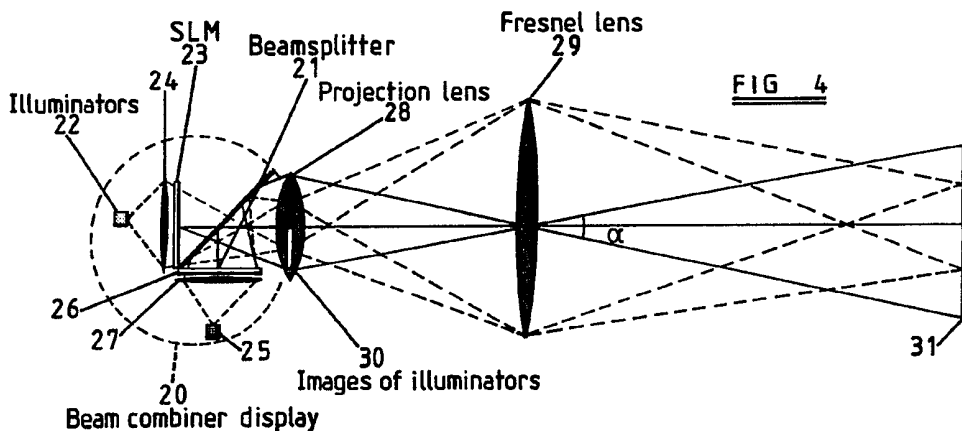

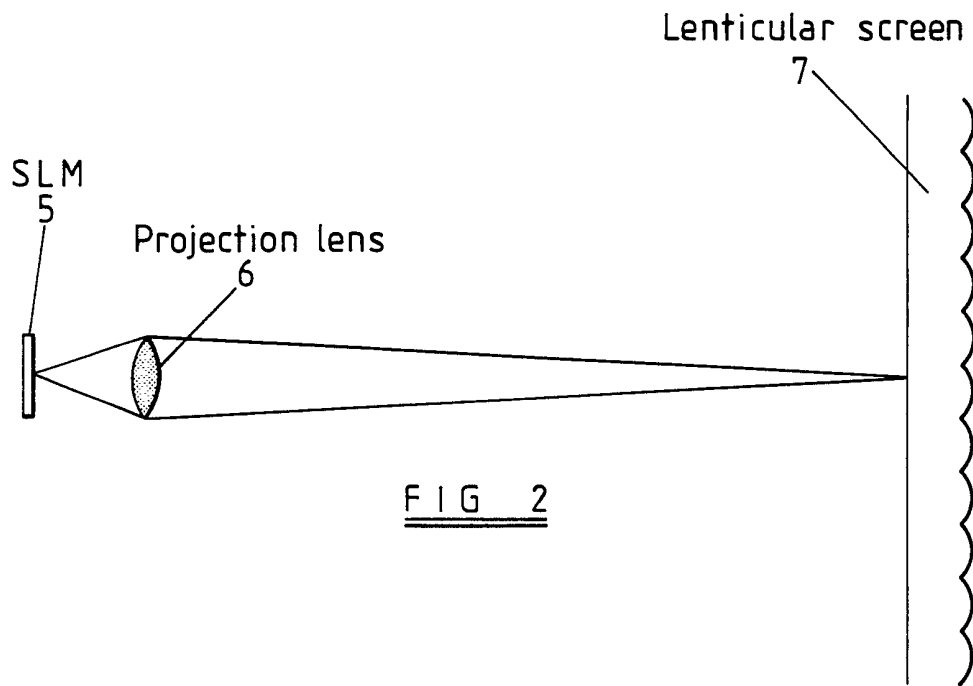
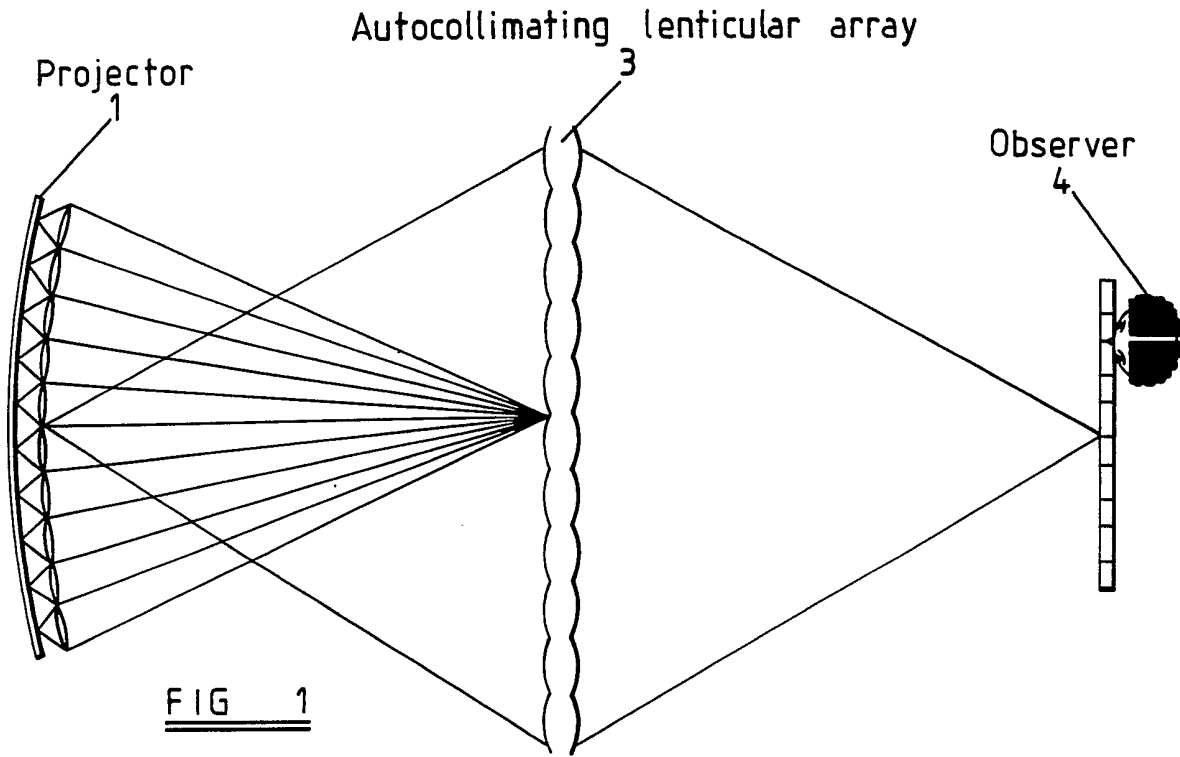

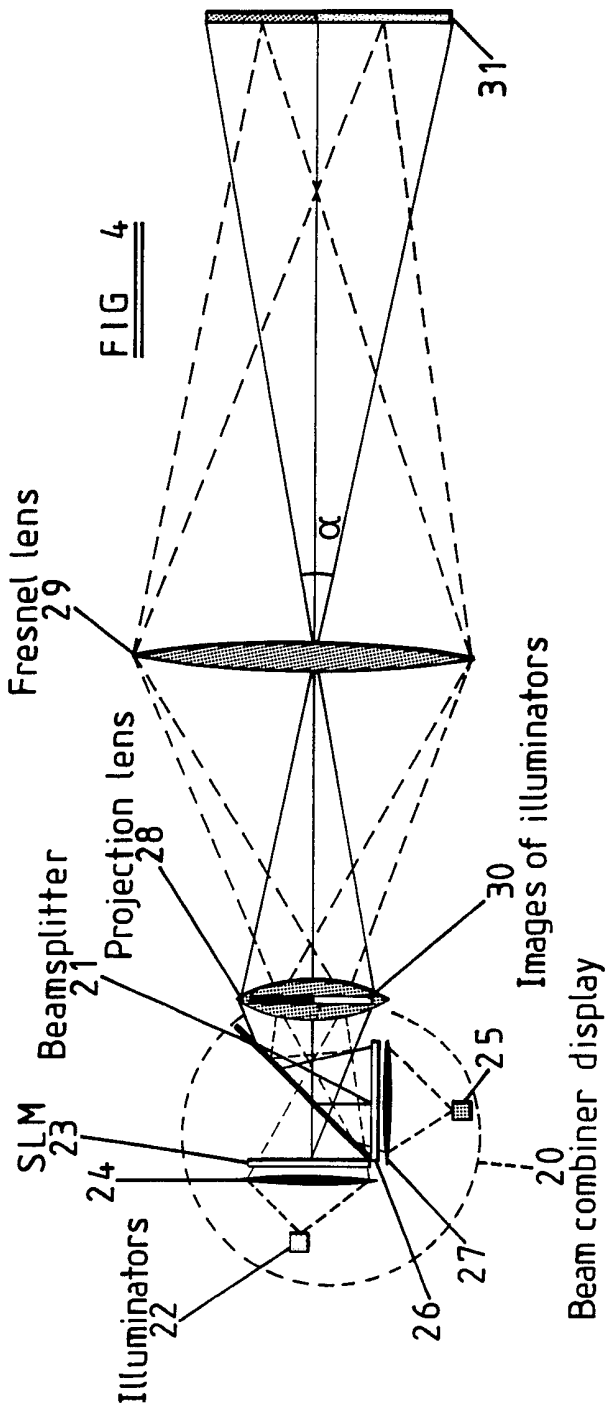
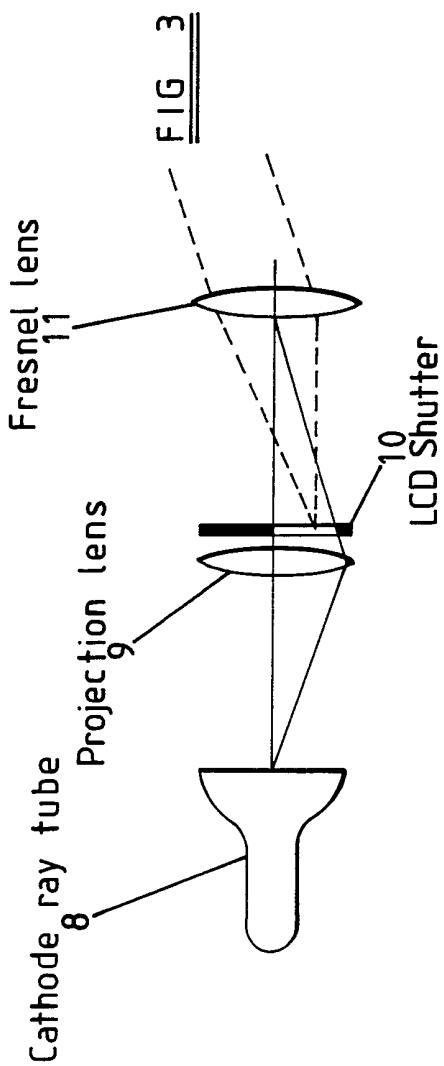
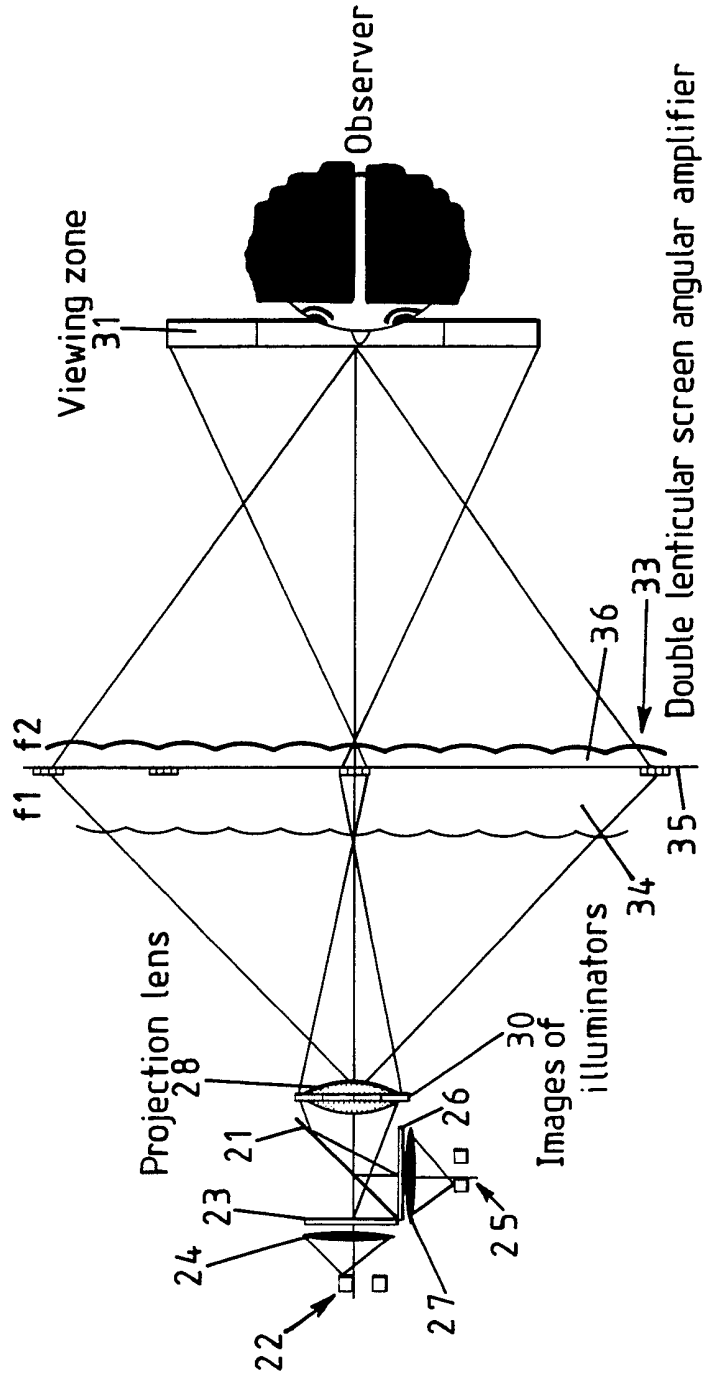
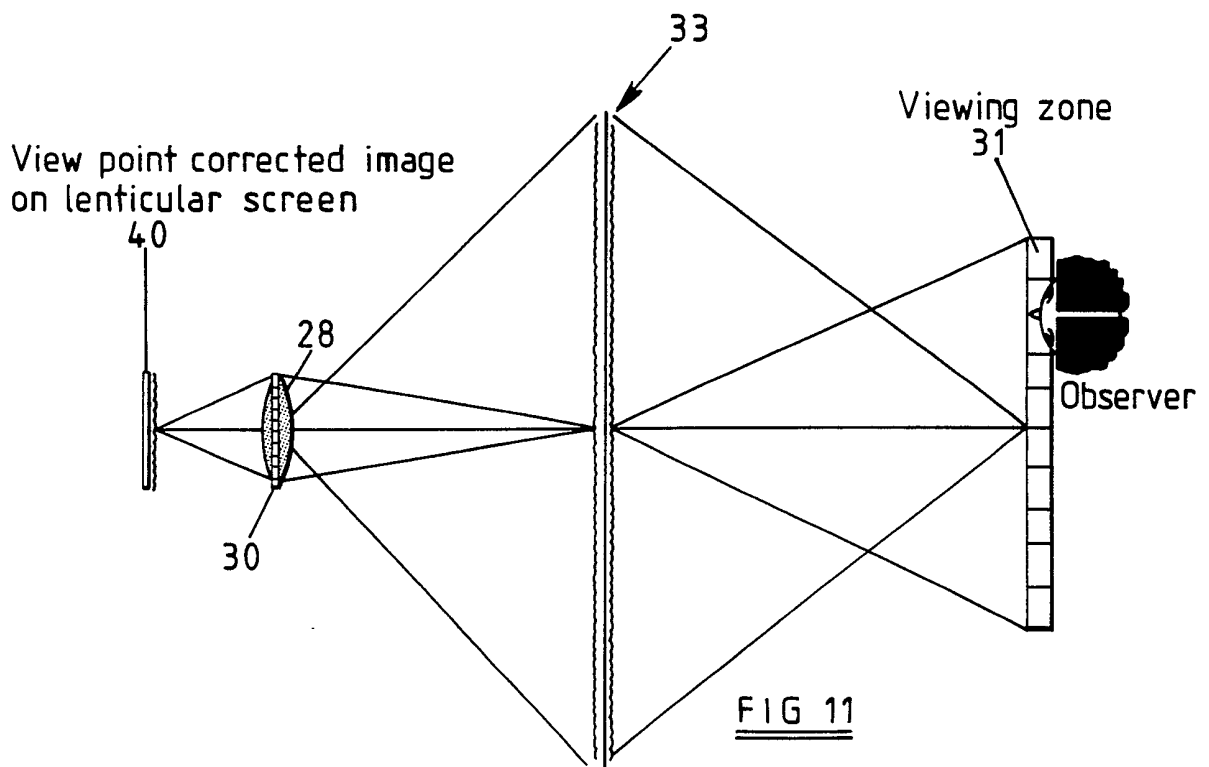
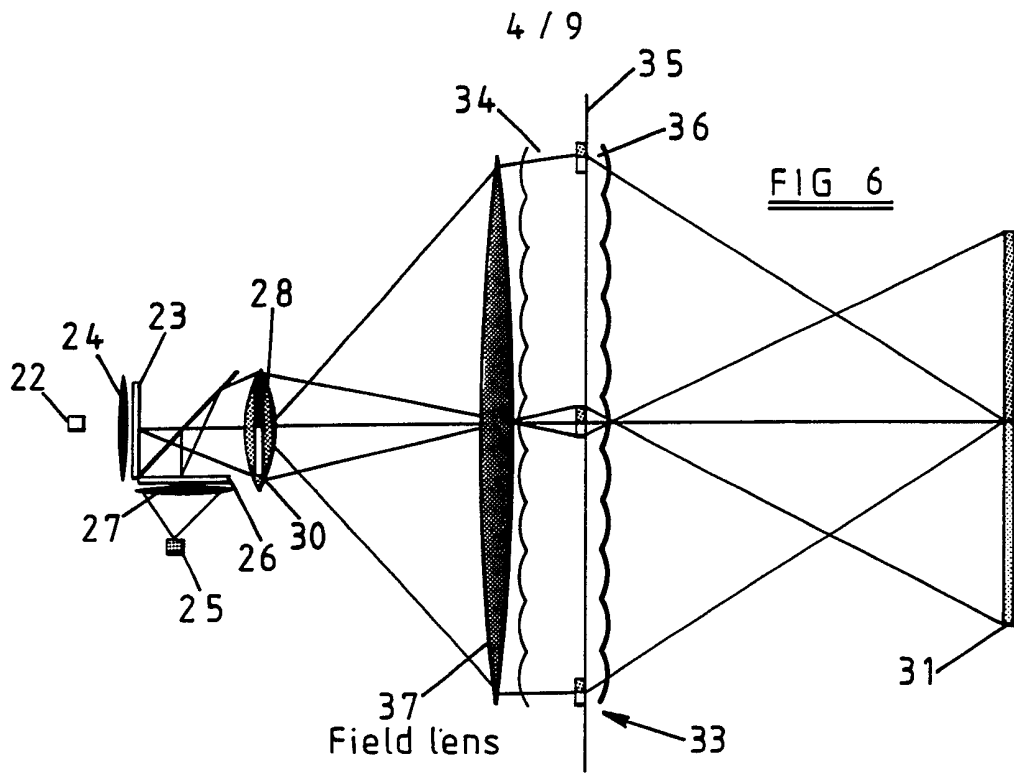
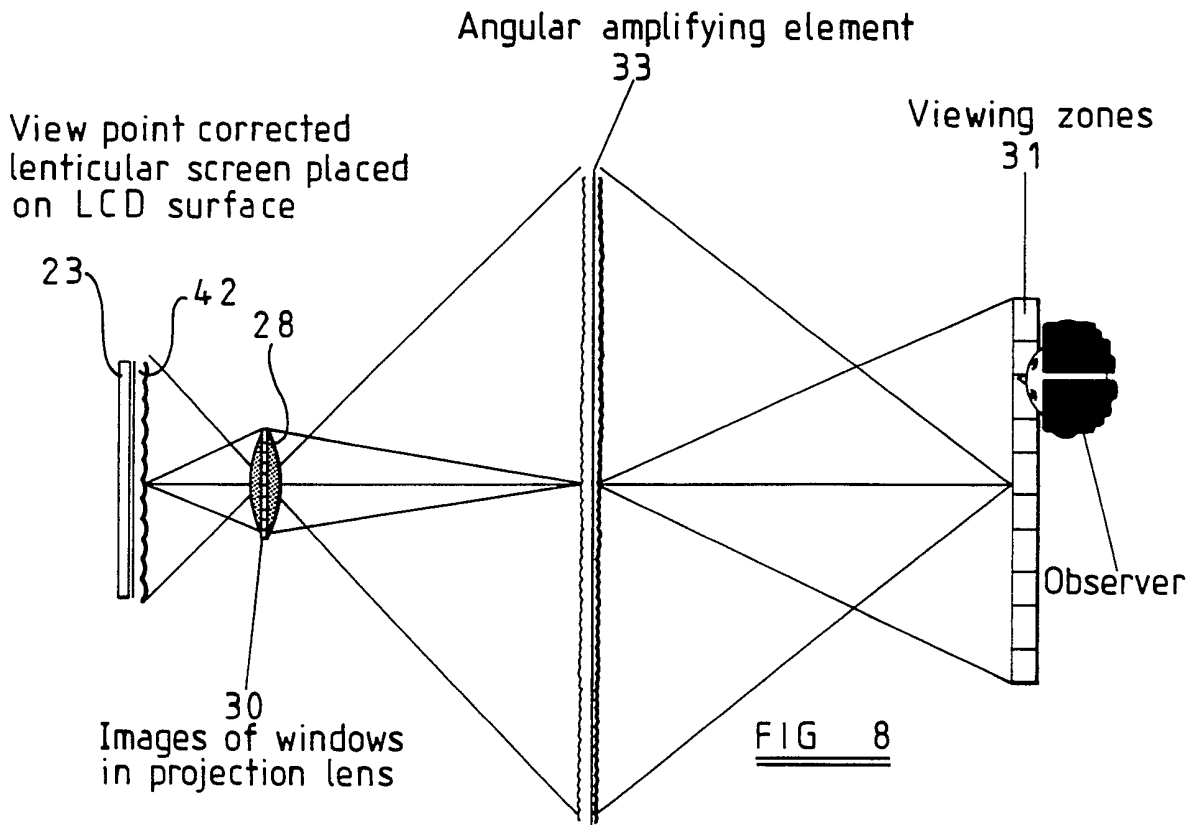
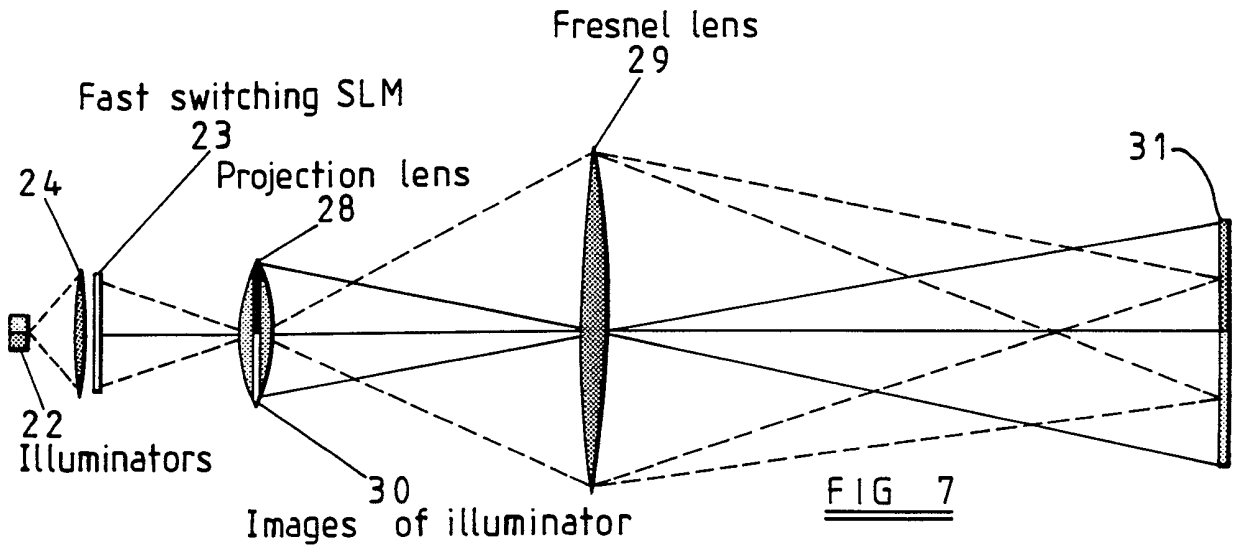

FIG 5







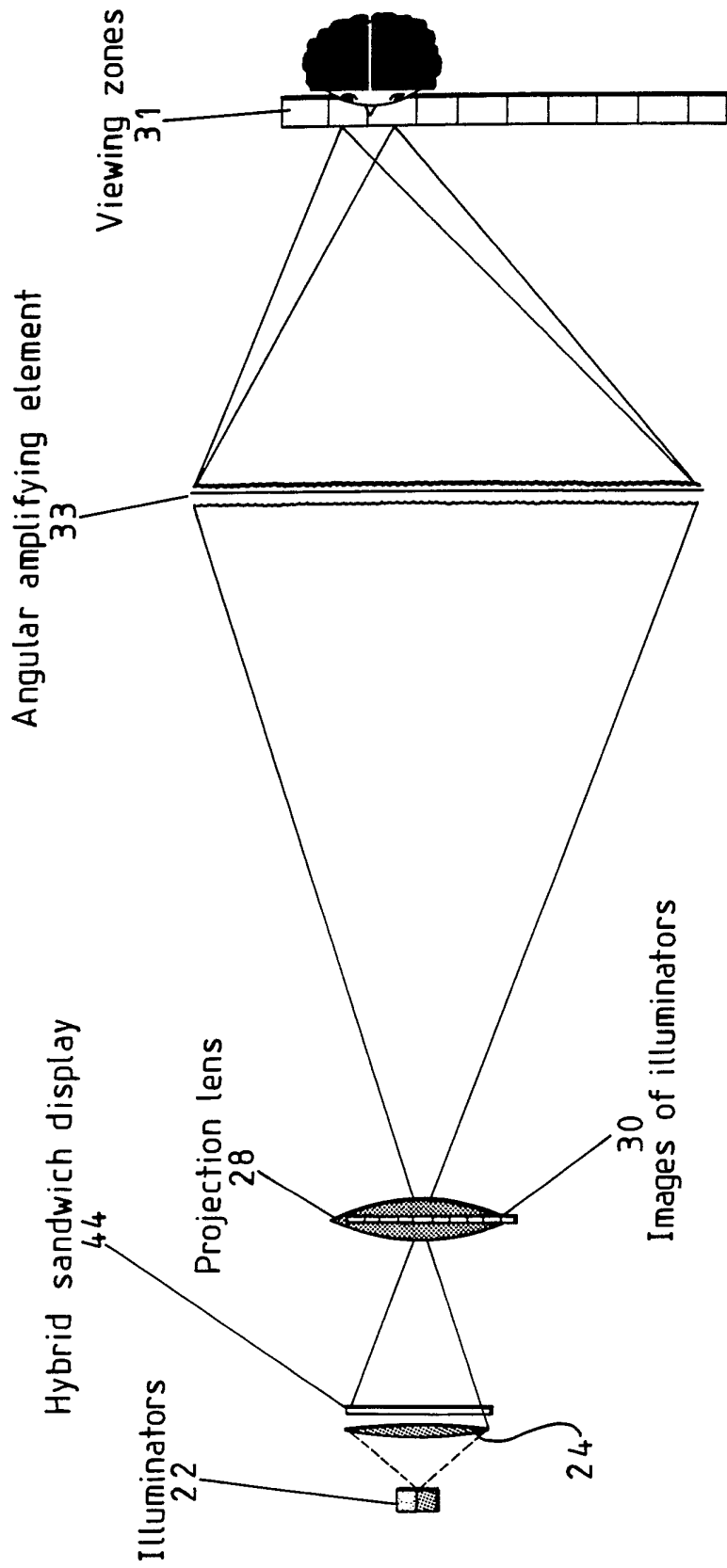
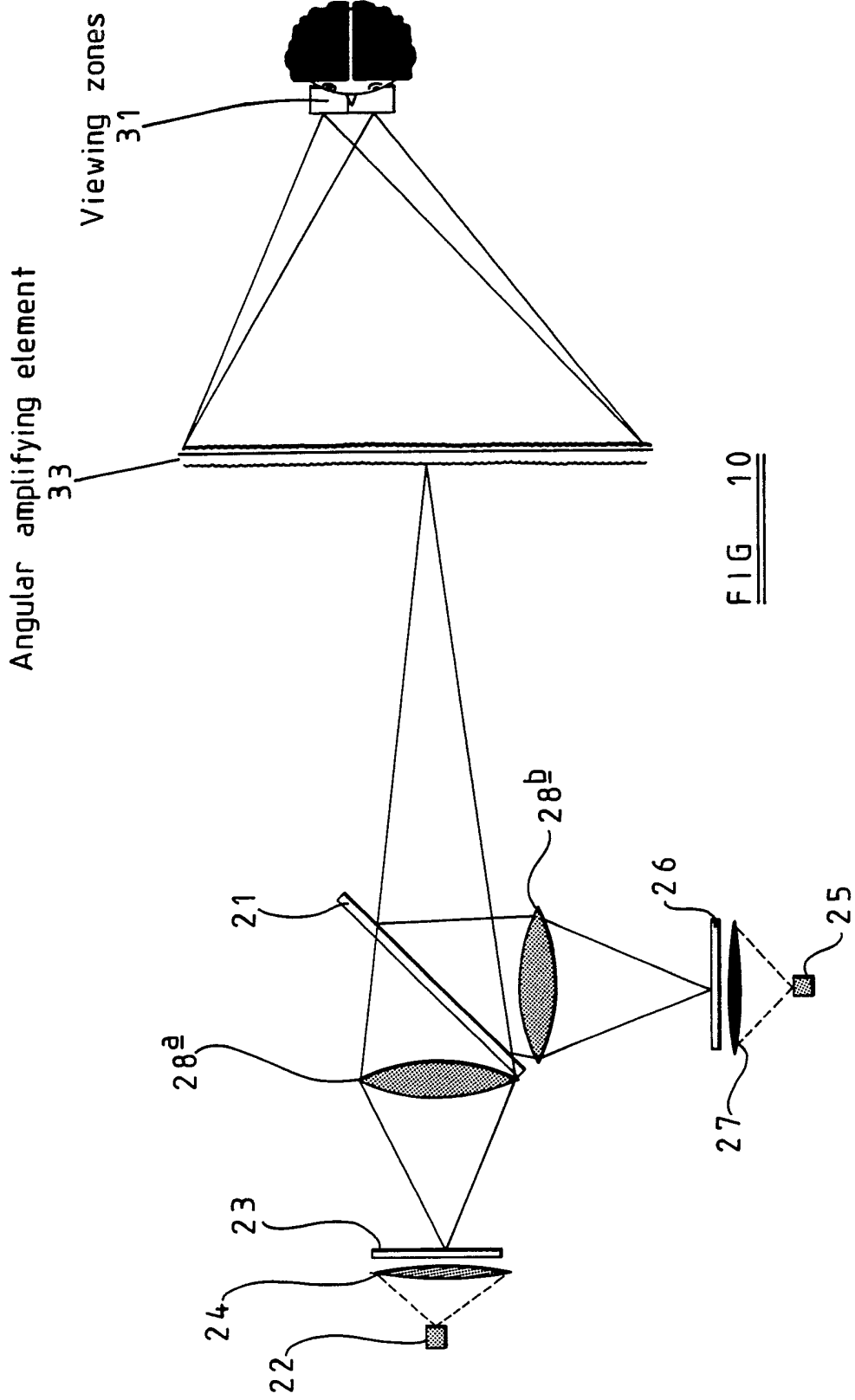

FIG 9



Angular amplifying element
33

Viewing zones
31

FIG 10

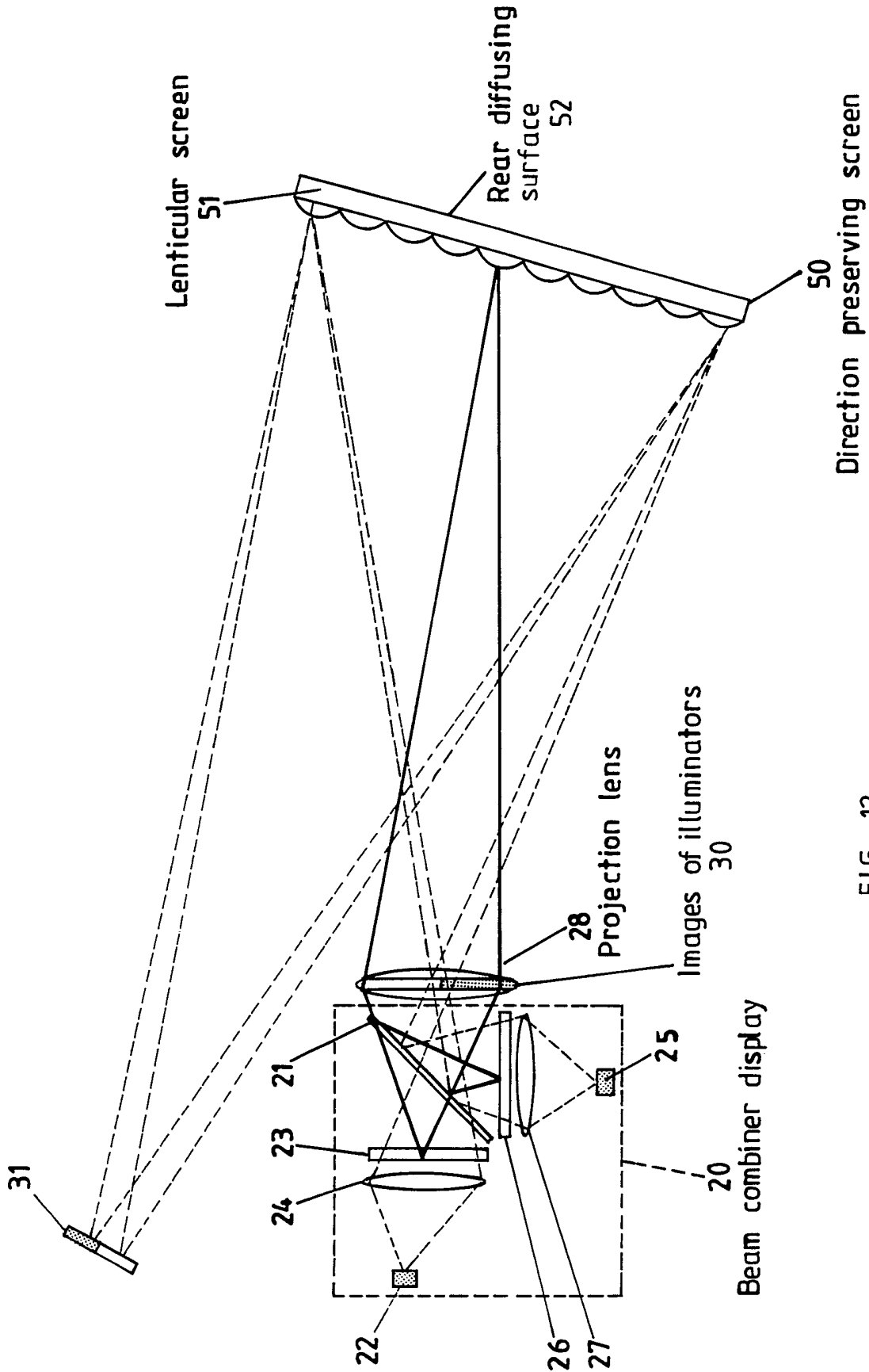

FIG 12

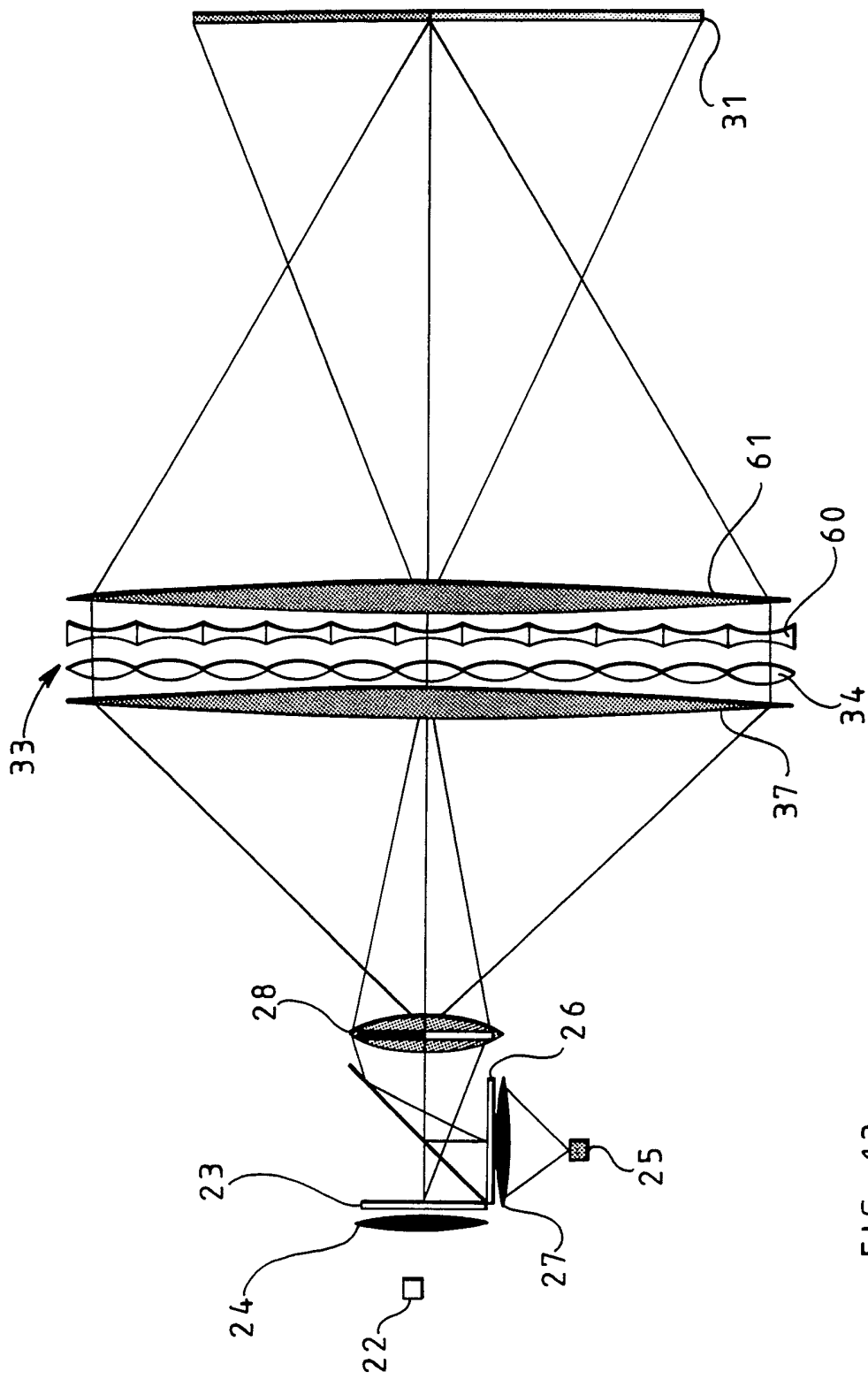

FIG 13

THREE-DIMENSIONAL PROJECTION DISPLAY APPARATUS.

The present invention relates to a three-dimensional (3D) projection display apparatus.

Figure 1 of the accompanying drawings shows a known large screen 3D display comprising a plurality of projectors 1, each of which projects an image representing a two-dimensional (2D) view. The output light beams of the projectors 1 are directed to an auto-collimating lenticular array 3. The 2D views are imaged at the array 3 and the light beams from the projectors are directed in different directions by the array 3 such that each eye of an observer 4 sees a different 2D view across the whole of the array 3, thus creating an autostereoscopic 3D image. Similar displays are disclosed in: "Survey of three dimensional television", James F. Butterfield, page 40 Proc. SPIE vol. 212 Optics and Photonics Applied to Three Dimensional Imagery (1979); and "Electronic Registration for an Autostereoscopic Lenticular 3D TV on a CRT: An equivalent of a Varifocal lens for an electronic 3D display", M. Okada, J. Hamasaki, S. Utsunomiya, O. Takeuchi, First International Symposium on 3D Images (Paris 26-28 September, 1991).

A display of this type can provide a large 3D image, for instance of about 1 metre diagonal size, but requires a relatively large number of projectors in order to provide an acceptable number of 2D views. Such a display is therefore prohibitively bulky and expensive. Further, without the use of expensive anamorphic correcting optics in the projectors 1,

such a display suffers from keystone distortions between the projected images. Alternatively, real time electronic correction for keystone distortions may be necessary.

Figure 2 of the accompanying drawings shows another known type of projection 3D display using a single projector comprising a light source (not shown), a spatial light modulator (SLM) 5, and a projection lens 6. A plurality of spatially multiplexed 2D views is formed by the SLM and projected via the projection lens 6 on to a lenticular screen 7. However, in order to provide a large display with an adequate number of 2D views, the SLM 5 is required to provide a spatially multiplexed image having a resolution which is greater than can be provided by currently available devices. Further, very accurate control of registration of the images with respect to the lenticular screen is required which, in turn, requires a very well corrected projection lens 6. A similar type of system is disclosed in "50 inch autostereoscopic full colour 3D TV display system", Isono, Yasuda, Takemori, Kanayama, Yamada & Chiba, page 176 Proc. SPIE vol. 1669 Stereoscopic Displays and Applications III (1992).

Figure 3 of the accompanying drawings shows another known type of 3D autostereoscopic projection display comprising a cathode ray tube 8, a projection lens 9, a liquid crystal display (LCD) shutter 10, and a Fresnel lens 11. "The Design and Evaluation of a CRT based Autostereoscopic 3D Display", A.R.L. Travis, S.R. Lang, Proc. SID vol. 32/4, 1991. A temporally multiplexed image is provided on the screen of the cathode ray tube 8 and is imaged by projection lens 9 via the LCD shutter 10 on to the surface of the Fresnel lens 11. The temporally multiplexed image comprises a plurality of 2D views displayed in

sequence on the screen of the tube 8. The shutter 10 provides a plurality of laterally displaced and sequentially transparent regions for controlling the directions in which the 2D views are visible to an observer. The shutter 10 is disposed as close to the projection lens 9 as possible and in the focal plane of the Fresnel lens 11, so that collimated light is imaged from each point in the shutter plane by the lens 11. However, this type of display is capable of providing only a limited size of image and a limited field of view.

According to the invention, there is provided a 3D projection display apparatus as defined in the appended Claim 1.

Preferred embodiments of the invention are defined in the other appended claims.

It is thus possible to provide a 3D projection display apparatus which is capable of providing full colour or monochrome still or moving autostereoscopic images having a relatively large size and with an adequate number of views to provide an acceptable 3D image. Such an apparatus may be used for 3D television, 3D computer aided design and graphics, 3D medical imaging, virtual reality, and computer games. Also, such a display may be used to provide projection of hard copy from a computer peripheral full colour 3D printer. It is further possible to increase the image size of the 3D display while maintaining the required angular separation of the output views of the apparatus. This may be achieved with a single relatively low aperture projection lens.

It is also possible to provide a large size 3D display with a large field of view using a single projection lens of relatively small output numerical

aperture.

The present invention will be further described, by way of example, with reference to the accompanying drawings, in which:

Figures 1 to 3 illustrate respective known types of projection autostereoscopic 3D displays; and

Figures 4 to 13 are diagrammatic cross-sectional views of 3D displays constituting a first to ninth embodiments, respectively, of the invention.

The 3D autostereoscopic display shown in Figure 4 comprises a beam combiner display 20 in which 2D views are combined by means of a beam splitter 21. One or more illuminators 22 illuminate a SLM 23 via a lens 24 to provide one or more 2D views which are transmitted through the beam splitter 21. Similarly, one or more illuminators 25 illuminate a SLM 26 via a lens 27 to supply one or more 2D views which are reflected by the beam splitter 21 in such a way that the view provided by the SLMs 23 and 26 are spatially multiplexed. For the purposes of illustration in Figure 4, a single illuminator 22 and a single illuminator 25 are shown.

The output light beams from the beam combiner display 20 are imaged by a projection lens 28 and supplied to an output screen in the form of a fresnel lens 29. Two imaging processes take place in the display. In accordance with the first imaging process, each of the illuminators 22 and 25 is imaged into a separate position, shown at 30, in the aperture of the projection lens 28. The images of the illuminators are re-imaged by the Fresnel lens 29 to form an image 31 of the illuminators at an

observer located at a defined image distance from the Fresnel lens 29.

In accordance with the second imaging process, the 2D images formed on the SLMs 23 and 26 are imaged by the projection lens 28 onto a front surface of the Fresnel lens 29. Thus, a different 2D view will be seen by the eyes of an observer when located at the images 31 of the illuminators 22 and 25. The image will appear in the plane of the Fresnel lens 29.

By imaging the illuminators at different positions in the aperture of the projection lens 28, the need for a shutter is eliminated, thus simplifying the display compared, for instance, with the display shown in Figure 3. A relatively large displayed image can be provided utilising SLMs of readily available type with acceptable resolution. Although Figure 4 illustrates a display in which only two 2D views are provided to form the 3D image, additional views can readily be provided. For instance, further beam splitters may be provided with additional illuminators, lenses, and SLMs. Alternatively, as mentioned hereinbefore, several illuminators may be provided for each SLM with the illuminators being illuminated one at a time and supplying light in respective different directions, with different 2D views being provided in sequence by each SLM, so as to provide temporal multiplexing of the 2D views. Beam combiner displays of this type are, for instance, disclosed in British Patent Application No.9226272.4.

Using the Fresnel lens 29 as the output screen of the display, the angular spread of views is limited by the output numerical aperture of the projection lens 28. If a large magnification of the images produced by the SLMs is required, then the output numerical aperture has to be

reduced, thus limiting the range of angles available. It is generally impractical to use very large projection lenses of sufficient imaging quality because of the expense.

To illustrate the problem, if the LCD size is 50 millimetres, with a 5:1 magnification by a 80 millimetre focal length projection lens of aperture $f/1.9$, then the image distance of the projection lens is 480 millimetres and the output numerical aperture $\alpha/2$ is 2.5 degrees. For four 2D views and a separation of the views at the observer of 65 millimetres, the observer will see a 3D image of size 250 millimetres at a distance of approximately 3,000 millimetres from the screen. This would be an unacceptable viewing distance for this image size.

The 3D display shown in Figure 5 overcomes this problem by using a double lenticular screen angular amplifier 33 as the output screen in place of the Fresnel lens 29. Also, the beam combiner display is shown as having two illuminators 22 and two illuminators 25 for providing four 2D views.

The double lenticular screen angular amplifier 33 is of a similar type to an arrangement disclosed in GB 541 753 and by Hutley and Stevens in an article entitled "The formation of Integral Images by Afocal Pairs of Lens Arrays ("Super-Lenses")", page 147 IOP Short Meetings No.30, 1st May, 1992. The angular amplifier 33 comprises a first lenticular array 34 having a focal length f_1 arranged to image each of the illuminators 22 and 25 at a plane diffuser 35. The images are re-imaged by a second lenticular array 36 having a focal length f_2 which is less than f_1 . The shorter focal length of the second lenticular array results in the angular spread of the views being increased, so that the separation of the 2D

views at the observer is increased and a reasonable angular spread is obtained. The aperture of the projection lens 28 may therefore be reduced while maintaining the appropriate separation of views at the observer.

Continuing the previously described numerical example, the output numerical aperture of the projection lens 28 in Figure 5 may be 2.5 degrees. For an observer distance from the screen of 1,000 millimetres and with four views with a spacing between adjacent views of 65 millimetres, a total output angular spread from the angular amplifier 33 of 15 degrees is required. A lenticular screen having a ratio $f_1:f_2$ of focal lengths equal to approximately 3:1 and with the lenses having substantially the same pitch would achieve this. For instance, f_1 may be 5.7 millimetres and f_2 may be 1.9 millimetres. The size of the image of the lens aperture behind each lenticular element (assuming a refractive index of 1.5) is approximately 0.5 millimetres, which defines the minimum lenticular pitch. The pixel sizes for a 500 x 500 pixel display at the 250 millimetre image projected on to the angular element 33 is 0.5 millimetres. Thus, it is possible to provide a 3D display of large size providing a large magnification and large angular spread of 2D views.

The 3D display shown in Figure 6 differs from that shown in Figure 5 in that a field lens 37 of the Fresnel type is provided adjacent the angular amplifier 33 on the side thereof facing the projection lens 28. The field lens 37 is arranged to image the ray bundles in the appropriate directions on to the angular amplifier 33 such that, for each particular source, a single image is generated by the angular amplifying screen at the observer plane. Although such an arrangement may be provided without a field lens by controlling the relative pitch of the lenticular screens 34

and 36, the manufacturing tolerances required to achieve this are very tight. The same result can be achieved with the Fresnel field lens 37 with the position and focal length thereof suitably adjusted and such an arrangement requires lower manufacturing tolerances.

The display shown in Figure 7 differs from that shown in Figure 4 in that the beam combiner display 20 is replaced by a temporally multiplexed display. The temporally multiplexed display comprises contiguous illuminators 22 which illuminate a fast switching SLM 23 via a lens 24 to provide two temporally multiplexed 2D views. First and second 2D views are alternately displayed by the SLM 23 in synchronism with illumination of first and second of the illuminators, respectively.

The display shown in Figure 8 differs from that shown in Figure 5 in that the beam combiner display is replaced by a spatially multiplexed display. The spatially multiplexed display comprises a viewpoint corrected lenticular screen 42 disposed on the surface of a SLM 23 in the form of a liquid crystal device (LCD). The LCD displays spatially multiplexed 2D images such that strips of the images are interlaced in groups with each group aligned with a respective lenticule of the screen 42. The LCD 23 is suitably illuminated, for instance by a diffuse light source (not shown).

The display shown in Figure 9 differs from that shown in Figure 5 in that the beam combiner display is replaced by illuminators 22, a lens 24, and a hybrid sandwich display 44. The display 44 is of the type disclosed in European Patent Application No.93303590.9 and for instance comprises an input lenticular screen, an SLM, a diffuser, and an output lenticular screen. The display 44 provides both spatially and temporally multiplexed 2D views.

The display shown in Figure 10 differs from that shown in Figure 4 in that the fresnel lens 29 is replaced by an angular amplifier 33 and the projection lens 28 is replaced by first and second projection lenses 28a and 28b. The lens 28a is disposed between the beam splitter 21 and the SLM 23 whereas the lens 28b is disposed between the beam splitter 21 and the SLM 26.

As shown in Figure 11, the projection display may be used to project a printed image. The printed image comprises a lenticular screen 40 on which is printed a view point corrected image comprising spatial multiplexed 2D views, for instance produced by means of the techniques disclosed in GB 9222346.0. By suitably illuminating from the back or the front the lenticular screen 40, the image is projected on to the angular amplifier 33.

The projection display shown in Figure 12 comprises a beam combiner display 20 and projection lens 28 which are of the type shown in Figure 4 and which will not be described further. The display of Figure 12 differs from the previous displays in that the light transmitting screens in the forms of the Fresnel 29 and angular amplifier 33 are replaced by a reflective arrangement in the form of a direction preserving screen 50. The screen 50 comprises a lenticular screen 51 having a rear diffusing surface 52. The beam combiner display 20 may be replaced by any other suitable type of display, such as one of the types shown in the other drawings.

In use, the beam combiner display 20 images into a higher order lobe of the lenticular screen 51 with observation in the zeroth lobe. However, other modes may be used. For instance, the beam combiner display 20

and the projection lens 28 may be disposed above the viewing zone 31 so that vertical diffusion at the diffusing surface 52 allows observation of the 3D image.

The direction preserving screen 50 may be flat or curved as described by R. Borner, "Progress in Projection of Parallax Panoramagrams onto Wide Angle Lenticular Screens", page 35, SPIE vol. 761 "True 3D Imaging Techniques and Display Technologies" (1987). The use of the beam combiner display 20 can simplify reflective mode projection displays by replacing the plurality of projectors used in known systems and hence reducing problems with "keystone" distortion.

The display shown in Figure 13 differs from that shown in Figure 6 in that the diffuser 35 is omitted, the lenticular screen 36 is replaced by a lenticular screen 60 comprising optically diverging elements, and a further field correction lens 61 is provided on the opposite side of the angular amplifying screen 33 from the first field correction lens 37. Although two field correction lenses 37 and 61 are shown in Figure 13, it is possible to use a single field correction element, such as a single lens. Each lens of the screen 34 cooperates with the corresponding lens of the screen 60 to form a Galilean telescope, so that the angular amplifier 33 shown in Figure 13 effectively functions in the same way as the angular amplifier 33 of Figure 6.

The image plane of the lenticular screen 34 coincides with the object plane of the lenticular screen 60, these coincident planes being disposed to the right of the screen 60 in Figure 13. Thus, the focal length of the diverging lenses of the screen 60 is less than the focal length of the converging lenses of the screen 34.

CLAIMS:

1. A three-dimensional projection display apparatus, comprising autostereoscopic image producing means for directing light beams corresponding to respective views in different directions, at least one projection lens co-operating with the image producing means to image the light beams at respective different regions in the aperture of the projection lens, and a light-transmissive or light-reflective screen co-operating with the image producing means and the projection lens to image the views at the screen.
2. An apparatus as claimed in Claim 1, in which the screen comprises a converging lens.
3. An apparatus as claimed in Claim 2, in which the converging lens is a Fresnel lens.
4. An apparatus as claimed in Claim 1, in which the screen comprises a diffuser, a first array of converging lenses disposed on a first side of the diffuser for receiving light from the or each projection lens, and a second array of converging lenses disposed on a second side of the diffuser, the lenses of the second array having a focal length less than that of the lenses of the first array.
5. An apparatus as claimed in Claim 1, in which the screen comprises a first array of converging lenses for receiving light from the or each projection lens, a second array of diverging lenses having a focal length less than that of the lenses of the first array, and a field correction element.

6. An apparatus as claimed in Claim 4 or 5, in which each of the first and second arrays comprises a lenticular screen comprising cylindrical lenticles.
7. An apparatus as claimed in Claim 4, in which a field lens is disposed between the projection lens and the first array.
8. An apparatus as claimed in Claim 7, in which the field lens is a Fresnel lens.
9. An apparatus as claimed in Claim 1, in which the screen comprises a direction-preserving lenticular screen having a rear diffusing surface.
10. An apparatus as claimed in any one of the preceding claims, in which the image producing means comprises at least one spatial light modulator and a plurality of light sources arranged such that the light sources are imaged at the respective different regions in the aperture of the projection lens and the or each spatial light modulator is imaged at the screen.
11. An apparatus as claimed in Claim 10, in which the image producing means comprises a beam combiner co-operating with first and second display means.
12. An apparatus as claimed in Claim 11, in which the at least one projection lens comprises first and second projection lenses disposed between the beam combiner and the first and second display means, respectively.

13. An apparatus as claimed in Claim 11 or 12, in which each of the first and second display means comprises a spatial light modulator and at least one light source.
14. An apparatus as claimed in any one of Claims 10 to 13, in which the or each spatial light modulator is arranged to display temporally multiplexed 2D views and the plurality of light sources are arranged to illuminate the spatial light modulator in respective different directions corresponding to the 2D views.
15. An apparatus as claimed in any one of Claims 10 to 13, in which the or each spatial light modulator is arranged to display spatially multiplexed 2D views and co-operates with a respective parallax screen.
16. An apparatus as claimed in Claim 15, in which the parallax screen comprises a lenticular screen.
17. An apparatus as claimed in any one of Claims 10 to 13, in which the or each spatial light modulator is disposed between an input lenticular screen and an output lenticular screen whose pitch is greater than that of the input lenticular screen.
18. An apparatus as claimed in any one of Claims 1 to 9, in which the image producing means comprises a substrate carrying a spatially multiplexed image of the views and a lenticular screen.
19. An apparatus as claimed in Claim 18, in which the lenticular screen is the substrate.

20. An apparatus substantially as hereinbefore described with reference to and as illustrated in any one of Figures 4 to 13 of the accompanying drawings.

15

Relevant Technical Fields

(i) UK Cl (Ed.M) G2J (JB7P, JX15)

(ii) Int Cl (Ed.5) G02B 27/22

Search Examiner
 R E HARDY

Date of completion of Search
 6 JANUARY 1994

Databases (see below)

(i) UK Patent Office collections of GB, EP, WO and US patent specifications.

(ii)

Documents considered relevant following a search in respect of Claims :-
 ALL

Categories of documents

- X:** Document indicating lack of novelty or of inventive step. **P:** Document published on or after the declared priority date but before the filing date of the present application.
- Y:** Document indicating lack of inventive step if combined with one or more other documents of the same category. **E:** Patent document published on or after, but with priority date earlier than, the filing date of the present application.
- A:** Document indicating technological background and/or state of the art. **&:** Member of the same patent family; corresponding document.

Category	Identity of document and relevant passages	Relevant to claim(s)
X	GB 0851404 A (KODAK) Figure 1 with single lens 17	Claim 1 at least
X	EP 0309630 A1 (SUMIKIN JISHO) Figure 1 and column 4 lines 16-20	Claim 1 at least
X	WO 88/08146 A1 (HOLTRONIC) Figure 4	Claim 1 at least
X	US 5122650 A (McKINLEY) Figure 2	Claim 1 at least
X	US 4756601 A (SCHRODER) Figure 1, lens 10	Claim 1 at least
X	US 4469415 A (RADL) The figure, lens 16	Claim 1 at least
X	US 3674339 A (SAYANAGI) Figures 2-6	Claim 1 at least

Databases: The UK Patent Office database comprises classified collections of GB, EP, WO and US patent specifications as outlined periodically in the Official Journal (Patents). The on-line databases considered for search are also listed periodically in the Official Journal (Patents).