

(No Model.)

W. C. WENDTÉ.

FLEXIBLE PRINTING FORM AND MEANS FOR SECURING THE SAME IN PLACE.

No. 415,132.

Patented Nov. 12, 1889.

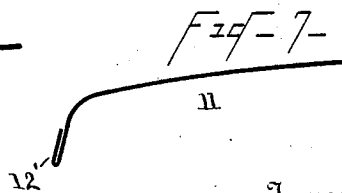
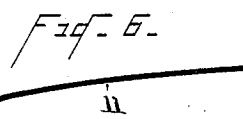
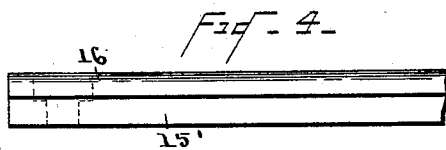
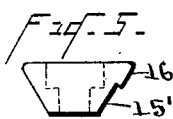
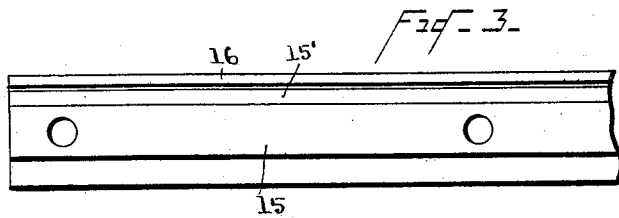
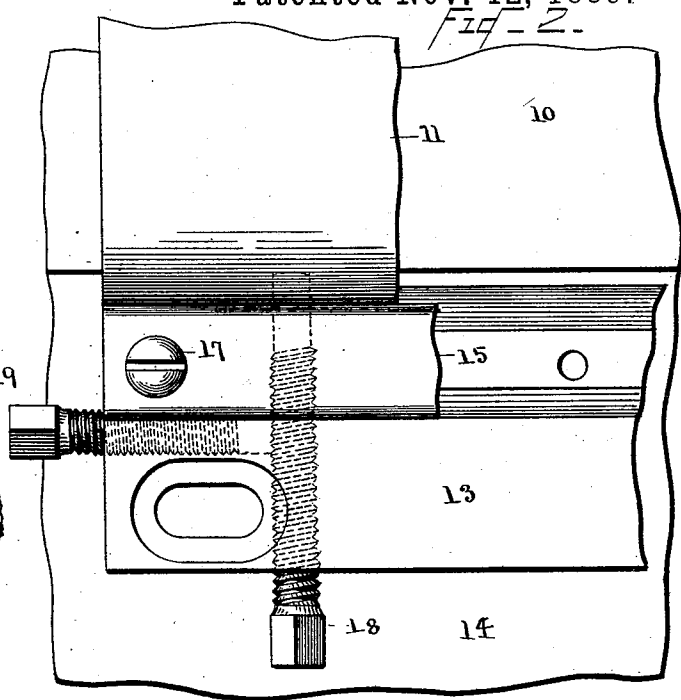
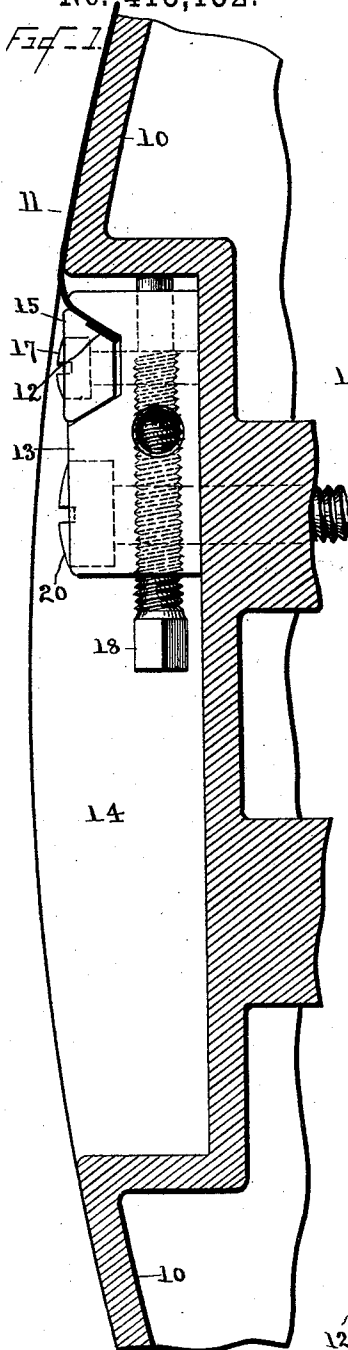

Witnesses
Norris A. Clark
E. Cook

Inventor
William C. Wendt
By J. W. Hobbes
Attorney

UNITED STATES PATENT OFFICE.

WILLIAM C. WENDTÉ, OF LANCASTER, ASSIGNOR TO WILLIAM H. FORBES,
OF BOSTON, MASSACHUSETTS.

FLEXIBLE PRINTING-FORM AND MEANS FOR SECURING THE SAME IN PLACE.

SPECIFICATION forming part of Letters Patent No. 415,132, dated November 12, 1889.

Application filed December 26, 1888. Serial No. 294,627. (No model.)

To all whom it may concern:

Be it known that I, WILLIAM C. WENDTÉ, a citizen of the United States, and a resident of Lancaster, in the county of Worcester and State of Massachusetts, have invented a new and useful Improvement in Flexible Printing-Forms and Means for Securing the Same in Place, of which the following is a specification.

This invention is related to many devices for attaching electrotyped or stereotyped plates to form-cylinders, but is especially designed to hold and secure flexible zinc forms upon the convex surfaces where they are printed.

In the drawings forming part of this specification, Figure 1 shows part of a form-cylinder in elevation and section, with the end elevation of a straining-bar, and its clamp holding a flexible form in position for printing. Fig. 2 is a view of the same as seen from above, but part of the form is cut away and part of the clamping-strip removed to make the construction more intelligible. Fig. 3 is a view of the clamping-strip as seen from below. Fig. 4 is a side elevation of the clamping-strip alone, showing its recessed side. Fig. 5 is an end elevation of the same, and Figs. 6 and 7 show an edge view of the projecting strip upon the flexible sheet of metal constructed in two different ways.

In the drawings, 10 is a supporting form-surface, upon which a flexible sheet of zinc 11, or its equivalent, is to be secured. This is accomplished with the help of the straining-bar 13, placed across the press in the depression or gap 14 made for that purpose. This bar may extend from side to side of the form-cylinder, or may be as long as the width of the sheet of metal which is to be held by it.

The manner in which the attachment of the flexible form to the straining-bar is accomplished is an essential part of my invention. Hitherto it has been the usual custom to hold the ends of a flexible metal sheet which is to act as a form in the printing-press by simply grasping its extremities between jaws, which pinch it in the manner of a vise, the friction produced thereby giving security to the grip. To insure success by such means, great force had to be exerted by the clamp, which occa-

sioned trouble and loss of time, and when all was done did not always gain the end in view—namely, the positive holding of the metal plate. To enable the zinc to be held in such a way by the bar as to render its escape impossible, I provide a clamp of peculiar construction on the upper face of the straining-bar, and I also prepare the end edges of the zinc in a novel manner for seizure by said clamp. These arrangements are accomplished as follows:

In the straining-bar 13 a V-shaped groove is formed which runs its entire length, and an independent clamping-strip 15 is shaped like a wedge to correspond substantially with said groove. This is forced into the same by the clamping-screws 17. The flexible form 11 has left or constructed on its end edge the projection shown at 12, which is a part of the plate itself. This strip fits a depression, notch, or recess 15' on one side of the wedge-shaped clamping-strip 15, while the projecting part at 16 butts solidly against the upturned shoulder or edge of the zinc in contact with it. When, as shown in the drawings, the sheet of metal is bent downward and inserted between the recessed side of the clamping-strip 15 and the flat side of the V-shaped groove, and the former is then depressed by means of the screws 17, the two opposed and parallel faces, acting like the jaws of a vise, approach each other and grasp the thin metal between them, so that it is practically inextricable, except by releasing the screws 17. In clamping by this device it will be seen that the pressure exerted by the clamping screws is much increased upon the sheet metal by reason of the wedge shape given to the strip 15. This way of applying the necessary pressure I believe to be the best, because of the advantages stated and for the reason that, while the stiffness and solidity of the straining-bar is increased, all the movable parts used in grasping the ends of the flexible form can be easily kept clear of the form-rollers; but I am well aware that in place of the wedge-shaped strip plates or blocks suitably notched or recessed to receive and embrace the sheet metal and the projecting strip upon the same can be readily contrived, whereby approaching surfaces controlled by screws may be made

to embrace the ends of the flexible form which overhang the supporting form-surface and to fit the projections upon the same, substantially as above described.

5 When the sheet of zinc or other metal constituting the form which is to be held is moderately thick, I prefer to make the shoulder on the same by protecting with an etching-ground the strip which is to become the projection, and then etching down the metal inside said strip with an acid; or, with the help of a simple planing-tool, I cut away the metal mechanically parallel to the edge, leaving the projection stand, in a way that will be readily understood; but when the sheet of zinc is so thin that the removal of its substance to the requisite depth would weaken it too much and endanger its tearing, I proceed by turning over the edge of the metal and flattening it down in the manner shown in Fig. 7, so as to give rise to a projection 12', which is double the thickness of the original plate, or a narrow parallel strip of thin zinc may be soldered down upon the end of the form in the position which the turned-over strip would take. When in place and grasped by the clamp, the flexible form so prepared behaves exactly as if the projection were solid, as shown in Figs. 1 and 6.

30 The straining-bar shown in the drawings is adjusted, controlled, and fixed in position by the screws 18 and 19 and the bolts 20. The long screws 18 butt against the side of the gap 14 and force the bar backward, thereby drawing the sheet of metal held by its clamp tightly over the supporting form-surface 10. The screw 19, and a corresponding one at the other end of the bar, butt against the ends of the gap and serve to move the bar to and fro in the direction of its length. When properly placed, the bolts 20 hold it firmly, and with it the flexible form attached thereto. These adjusting devices need not be more fully described in this specification, because they are not my invention, nor an indispensable part of the improvements I have made.

45 In the foregoing statement of my invention and in the drawings, one straining-bar only, with the clamp forming part of the same, has been described and shown, as well as only one end of the zinc form with its relatively thickened edge. It need hardly be said that in most cases each flexible form is manipulated by two bars, one connected with each end thereof, and that one bar and its

appurtenances is an exact duplication of the other:

What I claim is—

1. In a printing-press, the combination of a supporting form-surface, a flexible form provided with a flat projecting strip left or added at its end, and a straining-bar having a clamp constructed to embrace and grasp said projection, substantially as described. 60

2. In a printing-press, the combination of a supporting form-surface, a flexible form provided with a projection at its end, a straining-bar for adjusting and holding said form, and a clamp connecting the bar and form, consisting of the bar provided with a V-shaped groove, and a wedge-shaped recessed strip fitted thereto, substantially as described. 65

3. A straining-bar provided with a clamp consisting of two opposing jaws or surfaces approached by screws, one of the same being notched or recessed to receive a flat projecting strip on the end of the flexible form controlled by said straining-bar, substantially as described. 75

4. A straining-bar provided with a clamp consisting of a bar having a V-shaped depression filled by a wedge-shaped strip, and controlled by screws, one of the sides of said wedge being notched or recessed to fit a projection on the end of the flexible form controlled by said straining-bar, substantially as described. 80

5. The combination, with a straining-bar provided with a V-shaped groove along its length, of a wedge-shaped clamping-strip fitting into said groove, and recessed on one of its sides to receive the relatively thickened edge of a flexible form, and with tightening-screws to hold said clamping-strip in place, substantially as described. 85

6. A flexible form for printing purposes provided at its ends with relatively thickened edges formed of flat projecting strips by which it may be firmly seized and held, substantially as described. 90

7. In a printing-press, an adjustable straining-bar carrying a clamp adapted to seize and retain a flat thickening strip on the end edge of a flexible form, when the same is in position upon its supporting form-surface, substantially as described. 100

WILLIAM C. WENDTÉ.

Witnesses:

JAS. B. BELL,
HORACE D. GOVE.