



(12) **DEMANDE DE BREVET CANADIEN
CANADIAN PATENT APPLICATION**

(13) **A1**

(86) Date de dépôt PCT/PCT Filing Date: 2019/05/09
(87) Date publication PCT/PCT Publication Date: 2019/11/14
(85) Entrée phase nationale/National Entry: 2020/11/09
(86) N° demande PCT/PCT Application No.: US 2019/031565
(87) N° publication PCT/PCT Publication No.: 2019/217710
(30) Priorités/Priorities: 2018/05/11 (US62/670,371);
2018/05/21 (US62/674,302)

(51) Cl.Int./Int.Cl. *B65D 75/58* (2006.01),
B65D 5/54 (2006.01), *B65D 5/56* (2006.01)
(71) Demandeur/Applicant:
SONOCO DEVELOPMENT, INC., US
(72) Inventeurs/Inventors:
HUFFER, SCOTT WILLIAM, US;
SANFILIPPO, JAMES, US;
SANFILIPPO, JOHN E., US;
RADENOVIC, MILORAD, US;
COSTA, RICARDO, US;
FELD, ERIC, US
(74) Agent: MARKS & CLERK

(54) Titre : EMBALLAGE STRATIFIE A L'EPREUVE DES ENFANTS ET PROCEDES DE REALISATION D'UN
EMBALLAGE STRATIFIE A L'EPREUVE DES ENFANTS
(54) Title: CHILD RESISTANT LAMINATE PACKAGES AND METHODS FOR MAKING A CHILD RESISTANT PACKAGE

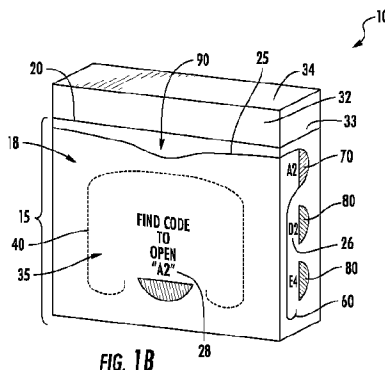
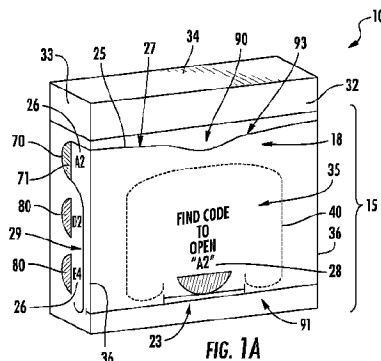

(57) **Abrégé/Abstract:**

The invention comprises a child resistant package having a first panel and at least two second panels joined to the first panel. The first and second panels are in different planes, in an embodiment. The package comprises a peelable flap portion covering an access point into the package, wherein the peelable flap portion has at least one tab continuous therewith. The at least one tab is disposed on one of the second panels and the access point is disposed in the first panel. In an embodiment, at least one decoy tab is also disposed on one of the second panels.

(12) INTERNATIONAL APPLICATION PUBLISHED UNDER THE PATENT COOPERATION TREATY (PCT)

(19) World Intellectual Property
Organization
International Bureau



(10) International Publication Number
WO 2019/217710 A1

(43) International Publication Date
14 November 2019 (14.11.2019)

- (51) International Patent Classification:
B65D 75/58 (2006.01) B65D 5/56 (2006.01)
B65D 5/54 (2006.01)
- (21) International Application Number:
PCT/US2019/031565
- (22) International Filing Date:
09 May 2019 (09.05.2019)
- (25) Filing Language: English
- (26) Publication Language: English
- (30) Priority Data:
62/670,371 11 May 2018 (11.05.2018) US
62/674,302 21 May 2018 (21.05.2018) US
- (71) Applicant: SONOCO DEVELOPMENT, INC. [US/US];
125 West Home Avenue, Hartsville, SC 29550 (US).
- (72) Inventors: HUFFER, Scott, William; 1216 Oakhaven Circle, Hartsville, SC 29550 (US). SANFILIPPO, James; 799 Plum Tree Road, Barrington, IL 60010 (US). SANFILIPPO, John, E.; 707 Plum Tree Rd, Barrington Hills, IL 60010 (US). RADENOVIC, Milorad; 5421 N East River Rd, Apt 817, Chicago, IL 60656 (US). COSTA, Ricardo; 1002 N Plum Grove Rd Apt216, Schaumburg, IL 60173 (US). FELD, Eric; 1900 Jericho Road, Aurora, IL 60506 (US).

- (74) Agent: HAYDEN, Nichole et al.; Nelson Mullins Riley & Scarborough LLP, One Wells Fargo Center, 301 South College Street, 23rd Floor, Charlotte, NC 28202 (US).
- (81) Designated States (unless otherwise indicated, for every kind of national protection available): AE, AG, AL, AM, AO, AT, AU, AZ, BA, BB, BG, BH, BN, BR, BW, BY, BZ, CA, CH, CL, CN, CO, CR, CU, CZ, DE, DJ, DK, DM, DO, DZ, EC, EE, EG, ES, FI, GB, GD, GE, GH, GM, GT, HN, HR, HU, ID, IL, IN, IR, IS, JO, JP, KE, KG, KH, KN, KP, KR, KW, KZ, LA, LC, LK, LR, LS, LU, LY, MA, MD, ME, MG, MK, MN, MW, MX, MY, MZ, NA, NG, NI, NO, NZ, OM, PA, PE, PG, PH, PL, PT, QA, RO, RS, RU, RW, SA, SC, SD, SE, SG, SK, SL, SM, ST, SV, SY, TH, TJ, TM, TN, TR, TT, TZ, UA, UG, US, UZ, VC, VN, ZA, ZM, ZW.
- (84) Designated States (unless otherwise indicated, for every kind of regional protection available): ARIPO (BW, GH, GM, KE, LR, LS, MW, MZ, NA, RW, SD, SL, ST, SZ, TZ, UG, ZM, ZW), Eurasian (AM, AZ, BY, KG, KZ, RU, TJ, TM), European (AL, AT, BE, BG, CH, CY, CZ, DE, DK, EE, ES, FI, FR, GB, GR, HR, HU, IE, IS, IT, LT, LU, LV, MC, MK, MT, NL, NO, PL, PT, RO, RS, SE, SI, SK, SM, TR), OAPI (BF, BJ, CF, CG, CI, CM, GA, GN, GQ, GW, KM, ML, MR, NE, SN, TD, TG).

(54) Title: CHILD RESISTANT LAMINATE PACKAGES AND METHODS FOR MAKING A CHILD RESISTANT PACKAGE

(57) Abstract: The invention comprises a child resistant package having a first panel and at least two second panels joined to the first panel. The first and second panels are in different planes, in an embodiment. The package comprises a peelable flap portion covering an access point into the package, wherein the peelable flap portion has at least one tab continuous therewith. The at least one tab is disposed on one of the second panels and the access point is disposed in the first panel. In an embodiment, at least one decoy tab is also disposed on one of the second panels.

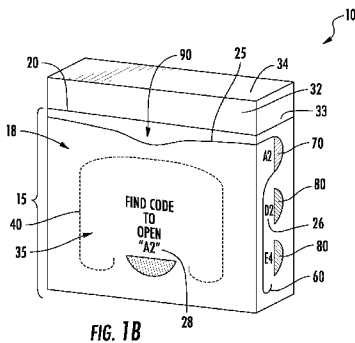
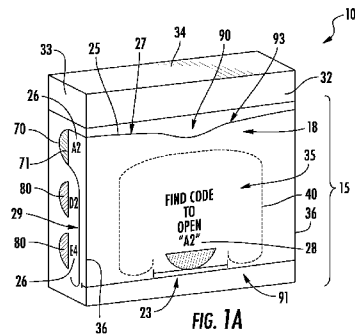

WO 2019/217710 A1

WO 2019/217710 A1 

Published:

- *with international search report (Art. 21(3))*
- *before the expiration of the time limit for amending the claims and to be republished in the event of receipt of amendments (Rule 48.2(h))*

TITLE

CHILD RESISTANT LAMINATE PACKAGES AND METHODS
FOR MAKING A CHILD RESISTANT PACKAGE

CROSS-REFERENCE TO RELATED APPLICATIONS

[0001] This application claims priority to U.S. Provisional Patent Application No. 62/670,371, filed May 11, 2018, entitled "Child Resistant Peelable Label" and U.S. Provisional Patent Application No. 62/674,302, filed May 21, 2018, also entitled "Child Resistant Peelable Label," wherein each of the foregoing is incorporated by reference in its entirety herein.

FIELD OF THE INVENTION

[0002] The present invention relates generally to the field of resealable flexible packaging and more particularly relates to peelable and resealable labels and integral packaging flaps which are child resistant.

SUMMARY OF THE INVENTION

[0003] In an embodiment, the invention comprises a child resistant laminate package comprising a first panel and at least two second panels joined to the first panel, wherein the second panels are disposed in a plane which is different from the plane of the first panel, and wherein the first and at least two second panels comprise: an inner layer; an outer layer; an adhesive layer disposed between the inner layer and the outer layer; wherein the outer film layer is scored to form at least one peelable flap portion comprising at least one tab which is continuous with the peelable flap portion, wherein the at least one tab is disposed at least partially on one of the at least two second panels; wherein the inner layer is scored to form at least one access point into the package, wherein the at least one access point is disposed at least partially within the

location of the peelable flap portion; and wherein the access point is disposed at least partially in the first panel.

[0004] In another embodiment, the invention comprises a child resistant laminate package comprising a first panel and at least two second panels joined to the first panel, wherein the second panels are disposed in a plane which is different from the plane of the first panel, and wherein the first and at least two second panels comprise: an inner layer; an outer layer; an adhesive layer disposed between the inner layer and the outer layer; wherein the outer film layer is scored to form at least one peelable flap portion comprising at least one tab which is continuous with the peelable flap portion, wherein the at least one tab is disposed on one of the at least two second panels; wherein the inner layer is scored to form at least one access point into the package, wherein the at least one access point is disposed at least partially within the location of the peelable flap portion; wherein the access point is disposed in the first panel; and wherein the perimeter of the peelable flap portion comprises a connecting portion and two leg portions and wherein a first leg portion is disposed substantially on one second panel of the package and a second leg portion is disposed substantially on a different second panel of the package.

[0005] In yet another embodiment, the invention comprises a child resistant laminate package comprising a first panel and at least two second panels joined to the first panel, wherein the second panels are disposed in a plane which is different from the plane of the first panel, and wherein the first and at least two second panels comprise: an inner layer; an outer layer; an adhesive layer disposed between the inner layer and the outer layer; wherein the outer film layer is scored to form at least one peelable flap portion

comprising at least one tab which is continuous with the peelable flap portion, wherein the at least one tab is disposed at least partially on one of the at least two second panels; wherein the inner layer is scored to form at least one access point into the package, wherein the at least one access point is disposed at least partially within the location of the peelable flap portion; wherein the access point is disposed at least partially in the first panel; and wherein at least one decoy tab is disposed on the at least one second panel such that the decoy tab is not scoredly continuous with the peelable flap.

[0006] The invention also comprises, in an embodiment, a method for making a child resistant package comprising: laminating an outer film layer to an inner film layer to form a laminate: forming an outer die cut in the outer film layer to define a peripheral edge of a peelable flap portion and at least one tab which is continuous with the peelable flap portion; forming an inner die cut in the inner film layer to define a location of an opening, wherein the inner die cut is formed inwardly of the outer die cut; printing at least one of the inner film and the outer film, wherein the print comprises at least one decoy tab which is visually similar to the at least one tab; and forming the laminate into a package having a first panel and at least two second panels joined to the first panel, wherein the second panels are disposed in a plane which is different from the plane of the first panel and the at least one tab and the at least one decoy tab is disposed on at least one of the second panels of the package.

[0007] In still another embodiment, the invention comprises a method for making a child resistant package comprising: laminating an outer film layer to an inner film layer to form a laminate; forming a first outer die cut in the outer film layer to define a

peripheral edge of a peelable flap portion and at least one tab which is continuous with the peelable flap portion; forming at least one additional outer die cut in the outer film layer to define at least one decoy tab, wherein the decoy tab is not continuous with the peelable flap portion; forming an inner die cut in the inner film layer to define a location of an opening of the package, wherein the inner die cut is formed inwardly of the first outer die cut; and forming the laminate into a package having a front panel and at least two side panels such that the at least one tab and the at least one decoy tab are disposed on at least one of the side panels of the package.

[0008] In another embodiment, the invention comprises a method for making a child resistant package comprising: laminating an outer film layer to an inner film layer to form a laminate: forming an outer die cut in the outer film layer to define a peripheral edge of a peelable flap portion and at least one tab which is continuous with the peelable flap portion; forming an inner die cut in the inner film layer to define a location of an opening, wherein the inner die cut is formed inwardly of the outer die cut; forming the laminate into a package having a first panel and at least two second panels joined to the first panel, wherein the second panels are disposed in a plane which is different from the plane of the first panel wherein the at least one tab is disposed on one of the at least two second panels; wherein the opening is disposed in the first panel; and wherein the peripheral edge of the peelable flap portion comprises a connecting portion and two leg portions and wherein a first leg portion is disposed substantially on one second panel of the package and a second leg portion is disposed substantially on a different second panel of the package.

BRIEF DESCRIPTION OF THE DRAWINGS

[0009] The accompanying drawings, which are incorporated in and constitute a part of this specification, illustrate one or more embodiments of the invention and, together with the description, serve to explain the principles of the invention. A full and enabling disclosure of the present invention, including the best mode thereof directed to one of ordinary skill in the art, is set forth in the specification, which makes reference to the appended drawings, in which:

[00010] Figure 1A illustrates a left side perspective view of an embodiment of a package with a child resistant label or flap;

[00011] Figure 1B illustrates a right side perspective view of an embodiment of a package with a child resistant label or flap;

[00012] Figure 2A is a top view of an embodiment of a child resistant label of the present invention;

[00013] Figures 2B and 2C are exploded views of interrupted areas in an embodiment of a child resistant label of the present invention;

[00014] Figure 3 is an alternate embodiment of a child resistant label according to an embodiment of the present invention;

[00015] Figures 4A and 4B are alternate embodiments of a child resistant label according to embodiments of the present invention;

[00016] Figures 5A-5C illustrate an alternate embodiment of a child resistant label according to an embodiment of the present invention, in a closed (5A), partially open (5B), and fully open (5C) configuration;

[00017] Figure 6 illustrates an alternate embodiment of a package with a child resistant integral flap according to an embodiment of the present invention;

[00018] Figure 7 illustrates a rollstock layer with discrete labels according to an embodiment of the present invention;

[00019] Figure 8 illustrates a packaging structure with an integrated peelable flap according to an embodiment of the present invention;

[00020] Figure 9 is an alternate embodiment of a child resistant label according to an embodiment of the present invention;

[00021] Figure 10 illustrates a packaging structure with an integrated peelable flap according to an alternate embodiment of the present invention;

[00022] Figure 11 illustrates a packaging structure with an integrated peelable flap according to an alternate embodiment of the present invention;

[00023] Figure 12 illustrates exemplary pull tabs in various embodiments of the present invention;

[00024] Figure 13 illustrates exemplary interrupted areas in various embodiments of the present invention; and

[00025] Figure 14 illustrates an alternate embodiment of a child resistant package according to an embodiment of the present invention.

[0026] Repeated use of reference characters in the present specification and drawings is intended to represent the same or analogous features or elements of the invention.

DETAILED DESCRIPTION OF THE EMBODIMENTS

[0027] Reference will now be made in detail to various embodiments of the invention, one or more examples of which are illustrated in the accompanying drawings. Each example is provided by way of explanation of the invention, not limitation of the

invention. In fact, it will be apparent to those skilled in the art that modifications and variations can be made in the present invention without departing from the scope or spirit thereof. For instance, features illustrated or described as part of one embodiment may be used on another embodiment to yield a still further embodiment. For example, the tab structures and configurations are interchangeable within and between embodiments. As another non-limiting example, the structures and configurations of the interrupted areas are interchangeable within and between embodiments. Thus, it is intended that the present invention covers such modifications and variations as come within the scope of the appended claims and their equivalents.

[0028] A variety of food and non-food products are packaged using flexible or semi-flexible packaging materials. Such packages may be formed from laminations of one or more of polymer films, metallized polymer films, paper, metal foil, and the like. In many instances, packages contain products that may be used or consumed a little at a time, and the products may be susceptible to being adversely affected (e.g., becoming soggy, drying out, etc.) by exposure to the surrounding environment. In these instances, there is a desire for resealable packaging. There is also a desire to prevent children from opening and accessing certain food and non-food products contained within resealable packages, such as packaging for laundry or dishwasher detergent tabs, pharmaceutical products, and/or food products which may contain ingredients that are unsafe or undesirable for consumption by children.

[0029] Through hard work and ingenuity, the inventors have invented a child resistant flexible packaging structure which has an integral resealable portion and have also invented a child resistant resealable label which can be applied to a separate

packaging structure. The inventive label and/or integral resealable flap is resistant to being opened by children and can be used to reclose the package after its initial opening to keep the product that remains in the package fresh. Once reclosed, the package is, once again, child resistant. That is, the child resistance is present before the initial opening of the package and continues after the initial opening of the package.

[0030] In an embodiment, the invention comprises a label that is discrete and may be attached to the exterior of a product package, adjacent to or over the location where the package opening is presented. This inventive label may be formed separately from the packaging structure and then added to the packaging structure, at the production or filling site, for example. Alternatively, the label may be registered and applied to the packaging structure during an in-line manufacturing process. The inventive label may be affixed to the packaging structure using pressure-sensitive adhesive, permanent adhesive, or any other adhesive known in the art.

[0031] In another embodiment, the invention may comprise a child resistant pressure-sensitive adhesive flap which is formed integrally with the flexible packaging structure. In this embodiment, the packaging may comprise two or more layers and the flap portion may comprise the package opening or cover the package opening.

[0032] Turning to the drawings, FIGS. 1A and 1B illustrate perspective views of a package **10** which comprises the inventive label **15**. It should be understood that regardless of the terminology used herein (i.e. label or integral flap), the invention may take the form of a separately applied label or an integrally formed flap. Any of the features described as part of a label may be equally applied to an integrally formed flap and vice versa.

[0033] The package **10** is shown in Figure 1 as a rectangular package, but it should be understood that the package **10** may comprise any shape or configuration known in the art. In some embodiments, the package **10** may comprise a standing pouch. In other embodiments, the package **10** may comprise a flexible bag, flow pack, gusted package, handled package, flat-bottom bag, quad seal bag, quattro seal bag, tetrahedral bag, brick bag, corner-creased bag, sachet, pillow pouch/pack, or any other bag or package known in the art.

[0034] The package **10** illustrated in FIGS 1A and 1B has a front panel **32**, a back panel opposite the front panel, a top panel **34**, a bottom panel opposite the top panel, and two side panels **33** which are opposite one another. In an embodiment, the access point **35** (shown in greater detail as item **535** in FIG. 6B) into the package **10** is disposed in the front panel **32**. However, the access point **35** may be disposed in any panel, face, or surface of the package **10**. The access point **35** may be defined by a score mark, die cut, or cut line **40** in the packaging structure. The cut line **40** may be discontinuous (i.e. may comprise an open shape, such as a U-shape) or may be a closed shape (i.e. cut line **340**, shown in FIG. 4). The cut line **40** may be perforated in some embodiments. The access point **35** in Fig. 1A is shown as covered by the label **15**.

[0035] Alternatively, the access point may be an opening or aperture formed in a packaging structure, such as via thermoformed structures. Still further, the access point may be a seam or seal which is opened or broken by the consumer to access the package contents. The access point **35** may be any feature which allows a user to access the contents of a package.

[0036] FIGS 1A and 1B illustrate the fact that the label **15** may, in an embodiment, cover some, most, or all of front panel **32** of the package **10** (or any other panel/face which contains the access point **35**). In this manner, the label **15** is disposed so that it covers the access point into the package **10** until the label **15** is at least partially peeled back from the package **10**. In an embodiment, the label **15** completely covers the access point **35** into the package **10**, until the label **15** is at least partially peeled back, such that the contents of the package **10** cannot be accessed when the label **15** is in a closed position. In an embodiment, the label **15** is sized and configured so that it at least covers (i.e. is longer and wider than) the perimeter of the access point **35**.

[0037] While the label **15** is shown as covering an access point **35** on the front panel **32**, it should be understood that if the access point **35** for the package **10** is disposed in the top panel **34**, for example, the label **15** will be disposed over such access point on the top panel **34**. The label **15** (or peelable integral flap) may be presented on any surface or panel of the package known in the art.

[0038] In an embodiment, the label **15** additionally extends onto one or both of the side panels **33**. In an embodiment, the label **15** extends onto both side panels **33**. In a particular embodiment, the label **15** extends substantially onto each side panel **33**. In yet another embodiment, the label **15** substantially or entirely covers each side panel **33**. In still another embodiment, the label **15** wraps from the front panel **32**, over each side panel **33**, and at least partially onto the back panel as well.

[0039] In an embodiment, the label **15** and access point **35** are disposed at least partially in a first panel and at least two second panels are disposed adjacent the first panel. In an embodiment, these second panels are connected to the first panel via a

fold, seam, or corner. In an embodiment, the second panels are disposed in a plane which is different from the plane in which the first panel is disposed. For example, the second panels may be disposed in a vertical plane while the first panel may be disposed in a horizontal plane. The first and second panels may be disposed at a non-zero angle with respect to each other. The angle may be a right angle, in an embodiment. In some embodiments, the angle between the first panel and each second panel is different. In other embodiments, the angle between the first panel and at least two of the second panels is the same.

[0040] In an embodiment, the label **15** is generally shaped and configured similarly to that of the package **10** to which it is applied or implemented as integral with. Thus, if the package **10** is generally rectangular, the overall label **15** or resealable flat portion may be generally rectangular.

[0041] The label **15** may comprise a cut line **25** which defines a peelable (and optionally resealable) flap portion **18**. The flap portion **18** may comprise any shape or configuration known in the art. In an embodiment, the flap portion **18** of the label **15** may mirror the general shape of the label **15** and/or package **10**. In an embodiment, the flap portion **18** covers the access point **35** and/or may mirror the shape of the access point **35**. In other embodiments, the flap portion **18** may have a generally squared or U-shaped perimeter. The flap portion **18** may have two or more sides defined by score line **25**. In an embodiment, the flap portion **18** has three sides defined by score line **25**. The score line **25** defining the flap portion **18** may have a connecting portion **27** and two downwardly-extending leg portions **29**. The flap portion **18** may be attached to the remainder of the label **15** and/or the package **10** along a hinge line **23** (i.e. an imaginary

line extending between the free ends of the two legs of the cut line **25**). The cut line **25** may be perforated in some embodiments. The terms cut line and score line may be used interchangeably herein.

[0042] In an embodiment, in addition to the label **15** extending onto one or both of the side panels **33**, the flap portion **18** may also extend onto one or both of the side panels **33**. In an embodiment, the flap portion **18** extends at least partially onto both side panels **33**. In a particular embodiment, the flap portion **18** extends substantially onto each side panel **33**. In a particular embodiment, the flap portion **18** extends to at least half of the dimension of at least one side panel **33**. For example, if the side panel **33** measures 3 inches in width, the flap portion **18** may extend at least 1.5 inches into the side panel. In other embodiments, the flap portion **18** extends nearly to half of the dimension of at least one side panel **33**.

[0043] Further, the cut line **25** may be disposed at least partially on one or both of the side panels **33**. In an embodiment, the cut line **25** extends at least partially onto both side panels **33**. In other embodiments, the label **15** extends onto one or both of the side panels **33**, but the flap portion **18** and cut line **25** are disposed on the front panel of the structure.

[0044] In a particular embodiment, the connecting portion **27** of the cut line **25** may be primarily disposed on the first panel (where the access point **35** is disposed) and the two downwardly-extending leg portions **29** of the cut line **25** may be primarily disposed on at least one of the second panels (which are adjacent the first panel). In another embodiment, the connecting portion **27** of the cut line **25** may be at least partially disposed on the first panel (where the access point **35** is disposed) and the two

downwardly-extending leg portions **29** of the cut line **25** may be at least partially disposed on at least one of the second panels (which are adjacent the first panel).

[0045] In an embodiment, cut line **25** defines at least one interrupted area **24** (shown, for example, in FIGS. 2A, 2B, and 2C). The interrupted area of the cut line **25**, in an embodiment, is an area which has not been cut or scored. The interrupted area **24** may comprise a small or thin area of film disposed between two portions of cut line **25**. When the resealable flap portion **18** is peeled back, at least a portion of the film in the interrupted area **24** is torn. In some embodiments, the interrupted area **24** can be formed by a transverse cut that is U-shaped or V-shaped (see FIG. 2C) to ensure that the tear will connect with the die cut **25**. Similarly, the interrupted area **24** can be formed by adjacent curvatures or 'j-hooks', as shown in FIG. 2B. In this embodiment, the end point of a first j-hook may direct the tear toward the beginning point of its adjacent j-hook. Any interrupted area **24** configuration, or any other package integrity feature known in the art is contemplated by the invention. For example, FIG. 2C illustrates y-cut interrupted areas, wherein the arrow portion of the y-cut points downwardly. The arrow portion of the y-cut could be reversed, as will be understood.

[0046] In an embodiment, the interrupted areas **24** may not only provide package integrity features, but may also hold the diecut **25** in place as it is manufactured and dispensed. The interrupted areas **24** may additionally or alternatively prevent the resealable flap portion **18** from unintentionally peeling upwardly or outwardly during manufacture, while on the retail shelf, and/or while in the consumer's possession, prior to opening of the container.

[0047] In an embodiment, the interrupted area **24** may serve as a tamper evidence feature. In this embodiment, the presence of a tear or slit in the interrupted area **24** indicates that the package has already been opened or tampered with. Prior to the resealable flap portion **18** being peeled back, the uncut condition of the interrupted area **24** may be readily apparent from a visual inspection. When the resealable flap portion **18** is peeled back, the peeling force tears through the interrupted areas **24** to connect the two or more portions of the score line **25** on opposite sides of each interrupted area **24**. If the resealable flap portion **18** is replaced to reseal the package, the torn condition of the interrupted area **24** may be readily apparent from a visual inspection. In an embodiment, printing on the package may include text or graphics adjacent to the interrupted areas **24** of the score line **25**, calling the consumer's attention to the presence of the interrupted areas **24** and/or indicating that if they are torn through, the consumer should not purchase and/or consume the package.

[0048] In an embodiment, the resealable flap portion **18** of the label **15** extends at least partially over one or more panels of the package **10** which are different from the panel which comprises the access point **35**. For example, if the access point **35** is disposed in the front panel **32**, the resealable flap portion **18** may cover the access point **35** disposed in the front panel **32** and may additionally extend at least partially over one or more side panels **33** or top and bottom panels. In an embodiment, the resealable flap portion **18** extends at least partially over one or more panels of the package **10** which are adjacent to the panel which comprises the access point **35**. In an embodiment, the resealable flap portion **18** extends at least partially over two panels of the package **10** which are adjacent to the panel which comprises the access point **35**.

In an embodiment, the resealable flap portion **18** extends at least partially over two panels of the package **10** which are opposite each other and adjacent to the panel which comprises the access point **35**.

[0049] In an embodiment, the resealable flap portion **18** has a first end **91** that is affixed to the package **10** and is not removable therefrom. In this embodiment, the resealable flap portion **18** also has a second, opposite end **93** that peels away from the package **10**. In an embodiment, the second end **93** of the resealable flap portion **18** is linear. In another embodiment, the second end **93** of the resealable flap portion **18** is generally linear with the exception of a recessed portion **90** which extends away from the second end **93** and toward the first end **91** of the resealable flap portion **18**. The recessed portion **90** may comprise any shape or configuration known in the art. In embodiment, the recessed portion **90** may be designed to prevent or discourage the consumer or user from opening the package **10** at the location of the recessed portion **90**. For example, the recessed portion **90** may be positioned in the location which would normally house a pull-tab. A consumer may be drawn, based upon habit, to open a package **10** from that location. The recessed portion **90** may discourage such behavior and may further discourage children from attempting to open the package **10** using the second end of the resealable flap portion **18**.

[0050] The recessed portion **90** may comprise a slight curvature toward the first end **91** of the package, toward the free ends of the leg portions **29** of the peelable flap portion **18**, or toward a hinge line **23** disposed between the free ends of the leg portions **29**. In an embodiment, the recessed portion is a U-shape, V-shape, or C-shape. The recessed portion **90** may be elongated and/or may be similarly sized to the access

opening **35**. In an embodiment, the cut line **25** is not readily visible to the consumer such that recessed portion **90** may not be visible or may not be obvious upon casual inspection of the package **10**.

[0051] In an embodiment, the cut line **25** terminates on either side of the access point **35** (i.e. the ends of the “U” if the resealable flap portion **18** is generally U-shaped) near the first end **91** of the package **10**. The termination point of the cut line **25** may comprise a “j-hook” **60** or a back hinge, but it should be understood that any mechanism which creates a stopping point that inhibits the complete removal of the resealable flap portion **18** from the product package could be utilized. In other embodiments, the cut line **25** may terminate at the end of the label **15**, or may be a closed shape, allowing the flap portion **18** to be completely removed from the product package. In an embodiment, the flap portion **18** is removable, but not resealable.

[0052] In a particular embodiment, the j-hooks **60** or back hinges are disposed in the same plane as the tab **70**. In an embodiment, the j-hooks **60** are disposed in a different plane from that of the tab **70**. In an embodiment, the j-hooks **60** and the tab **70** are disposed in the same plane, but in a plane which is a different plane from that of the access point **35** of the package. For example, the access point **35** of the package may be disposed on the front panel of the package while the tab **70** and/or the j-hooks **60** may be disposed on panels which are adjacent the front panel, but in a different plane from that of the front panel. In an embodiment, the panels containing the tab **70** and/or j-hooks **60** may be disposed at a non-zero angle from the panel containing the access point **35**. In an embodiment, this may be a 90 degree angle or may be substantially close to a 90 degree angle. In an embodiment, the panels containing the tab **70** and/or

j-hooks **60** may be disposed perpendicularly or substantially perpendicularly from the panel containing the access point **35**.

[0053] In an embodiment, disposing the j-hooks **60** or back hinges in a packaging plane which is different from that of the access point provides advantages to the invention. In an embodiment, the j-hooks **60** are “stay-open” features of the packaging structure. With reference to FIGS. 1A and 5C, as the package is opened using the tab **70** and the peelable flap **18**, the peelable flap **18** begins to stretch over the seam, corner, or fold **36** between the panel **32** containing the access point **35** and the panels **33** containing the j-hooks **60**. The peelable flap **18** may even buckle slightly at or near the hinge line **23** as the flap **18** is peeled to its fully open configuration. The stretching and buckling of the flap **18** over the folds **36** between the adjacent panels **32**, **33**, in the location of the hinge line **23**, forces the peelable flap **18** to remain in the open position (partially open position is shown in FIG. 5B; fully open position shown in 5C, buckling is shown across the hinge line **523**, over folds **536**). The package is unlikely to close without user-exerted effort when in this position. If the user desires to close the package, the user must then pull the peelable flap **18** outwardly and/or downwardly, toward the access point **35**, sufficiently to overcome the buckling along the hinge line **23**, in order to close the package.

[0054] In an embodiment, the cut line **25** which defines the resealable flap portion **18** comprises a continuous cut line which extends partially, but not fully, through the label **15**. In another embodiment, the cut line **25** which defines the resealable flap portion **18** comprises a continuous cut line which extends fully through the label **15**. In still another

embodiment, the cut line **25** which defines the resealable flap portion **18** comprises a perforated line which extends fully through the label **15** at the point of each perforation.

[0055] In an embodiment, the resealable flap portion **18** comprises at least one tab **70** which is grasped and pulled away from the packaging structure to lift the flap portion **18** and provide access to the container contents through the access point **35**. In an embodiment, resealable flap portion **18** comprises two tabs **70**. In an embodiment, resealable flap portion **18** comprises a plurality of tabs **70**.

[0056] In an embodiment, the tab(s) **70** may be disposed on a panel of the packaging structure which is different from the panel which comprises the access point **35** into the package. For example, if the access point **35** is disposed in the front panel **32**, the tab(s) **70** may be disposed on one or more side panels **33**. In this embodiment, the tabs **70** may be disposed in a location which would be considered the “grip” location of the package – i.e. the location wherein the user would hold or grip the package to conveniently open it. In this embodiment, the user may be required to change his/her grip and/or move his/her fingers in order to access the tabs **70** and pull them from the package **10**. This provides yet another layer of child resistance, as a child may not have the ability to change his or her grip in a manner that allows access to the tabs **70** while holding the package **10**.

[0057] Similarly, if the access point **35** is disposed in the top panel **34**, the tab(s) **70** may be disposed on the front panel **32** and/or the back panel, or alternatively may be disposed on one or more side panels **33**. In an embodiment, the tab(s) **70** are disposed on one or more panels which are adjacent the panel which comprises the access point **35**. Placing the tabs **70** on a panel which is different from the panel which comprises

the access point **35** into the package and/or comprises the primary label of the package **10** may be a deterrent to children attempting to access the package **10**. Children may be drawn to the labeling panel and may overlook the fact that the opening tabs **70** are located on separate panels.

[0058] In an embodiment, two or more tabs **70** may be utilized and may be disposed on different panels of the packaging structure. For example, if the access point **35** is disposed in the front panel **32**, the tabs **70** may be disposed on opposite side panels **33**. Similarly, if the access point **35** is disposed in the top panel **34**, the tabs **70** may be disposed on the front panel **32** and the back panel, or alternatively, may be disposed on opposite side panels **33**. In these embodiments, the two or more tabs **70** must be grasped and pulled away from the packaging structure in order to reveal the access point **35**. It may be required that the tabs **70** are grasped and pulled simultaneously or grasped and pulled in turn, in embodiments. Having two or more tabs **70** that must be used to open the package is an additional deterrent to children. Even if a child were to identify one opening tab **70**, it is less likely that the child would be able to locate both opening tabs **70** and simultaneously or progressively pull both.

[0059] In an embodiment, in order to reveal the access point **35**, the flap **18** must be pulled in multiple directions. For example, the resealable flap portion **18** may require that the tabs **70** are pulled in an upward direction and then the resealable flap portion **18** is pulled in an outward or downward direction, with reference to the packaging structure. Any directions known in the art are contemplated by the invention. Again, this serves as an additional deterrent to children. Not only must the opening tabs **70** be identified and one or both pulled or lifted in a first direction, but then the resealable flap portion **18**

must additionally be lifted or pulled in a second direction, thereby limiting the likelihood that a child will access the package contents.

[0060] The label **15** may be affixed to the package **10** through use of one or more adhesives. The adhesives may comprise any adhesive known in the art. In some embodiments, the adhesive may comprise a pressure sensitive adhesive ("PSA"). Any suitable PSA known in the art may be utilized in the present invention. The PSA may form viscoelastic bonds that are aggressively and permanently tacky, adhere without the need of more than a finger or hand pressure, and require no activation by water, solvent or heat. The PSA may be based on non-crosslinked rubber adhesives in a latex emulsion or solvent-borne form, or can comprise acrylic and methacrylate adhesives, styrene copolymers (SIS/SBS), and silicones. The adhesive may comprise an acrylic, a natural rubber, a synthetic rubber, a silicone, a butyl, or an ethylenevinylacetate ("EVA"). If the package of the invention is to be used for food packaging, the PSA may be a food-grade composition. In other embodiments, a cohesive may be utilized to affix some or all portions of the label **15** to the package **10**.

[0061] In a particular embodiment, a PSA is selected such that it can be flood coated or disposed to substantially cover the label **15** such that it secures the label **15** to the package **10**, but also allows the resealable flap portion **18** to release from the package **10**. Alternatively, more than one adhesive may be utilized, wherein the adhesives allow the bonding of the label **15** to the package **10** at different levels of affinity. For example, an adhesive having a greater bonding affinity may be selected and utilized to adhere the label **15** to the package **10** in certain areas outside of the resealable flap portion **18**. An adhesive having a lesser bonding affinity may be selected and utilized to adhere the

label **15** to the package **10** in the area of the resealable flap portion **18**. In an embodiment, the adhesive(s) utilized allow the resealable flap **18** to be separated from and resealed to the package **10** multiple times by the end user.

[0062] In an embodiment, the tabs **70** may be partially or entirely adhesive-free. In such an embodiment, for example, the outermost edge **71** of a tab **70** may be adhesive-free, allowing a user to slide a finger beneath the outermost edge **71** of a tab **70** to lift it. The portion of the tab **70** which is adhesive free may be located in any position of the tab, nearest the top, bottom, or rear of the packaging structure, in an embodiment. In an embodiment, the adhesive-free tabs **70** or portions thereof may be formed by deadening or deactivating any adhesive that has been applied in the location of the tab **70**, using any method known in the art. In another embodiment, the adhesive-free tabs **70** may be formed by pattern-applying the adhesive to the label **15** to avoid the location of the tabs **70**.

[0063] In an embodiment, the portion of the label **15** which covers the access point **35** may also or may alternatively be adhesive-free. This adhesive-free portion may be formed similarly to that described above. Providing a label which is adhesive-free in the location of the access point **35** may prevent the packaging contents from sticking to the label, in an embodiment.

[0064] In an embodiment, the label **15** additionally comprises decoy tabs **80**. In this embodiment, one or more decoy tabs **80** may be positioned adjacent or near the tabs **70**. The decoy tabs **80** may visually appear to be continuous with the flap portion **18**, in an embodiment, but may be scoredly discontinuous therewith. In other words, the decoy tabs **80** may look like they are connected to the flap portion **18** as a result of

printed matter and/or graphics, but the decoy tabs **80** either may not be scored at all or may be scored in a way that they are not continuous with the flap portion **18**. That is, only one side of the decoy tabs **80** may be scored or the score lines of the decoy tabs **80** may not connect to the score lines **25** of the peelable flap **18**.

[0065] The decoy tabs **80** may be designed such that they visually appear to be actual tabs that will aid in removing the resealable flap portion **18** from the package **10**. In an embodiment, however, the decoy tabs **80** may be visible as printed material only and may not be defined by a cut line, such that they are not separatable or removable from the label. Alternatively, the decoy tabs **80** may be defined by a cut line or partial cut line, but the cut line may not connect to the resealable flap portion **18** and, therefore, cannot aid in removing the resealable flap portion **18**. Similarly, the decoy tabs **80** may be defined by a cut line which is a closed shape that does not connect to the resealable flap portion **18**, such that when the decoy tab **80** is pulled, it is removed from the package **10** but does not peel back the resealable flap portion **18**. In yet another embodiment, the decoy tabs **80** may be defined by a cut line or partial cut line, but may not be adhesive-free, such that the decoy tabs **80** will not release easily from the package **10**.

[0066] In an embodiment, one or more decoy tabs **80** are disposed on the same panel as the tab(s) **70**. In a particular embodiment, two decoy tabs **80** are disposed on each panel which houses a tab **70**. The decoy tabs **80** provide additional means of confusion and distraction, preventing a child from easily knowing which tab is an opening tab **70** and/or how to open the package **10**. In an embodiment, the decoy tabs **80** are vertically aligned with each other and/or any tabs **70** disposed on the side panel.

[0067] In an embodiment, the decoy tabs **80** are visually similar to or identical to the tabs **70**. That is, the decoy tabs **80** may have the same (or substantially the same) shape, size, and/or color configuration as the tabs **70**. The decoy tabs **80** may be positioned in the same (or substantially the same) configuration as the tabs **70**. The decoy tabs **80** may be positioned parallel to the tabs **70**. In an embodiment, the decoy tabs **80** comprise a printed design that mimics the tabs **70**, but there is no cut line which actually defines the decoy tabs **80**.

[0068] In an embodiment, the tabs **70** and the decoy tabs **80** each display certain indicia **26**. In some embodiments, the indicia **26** may comprise graphics, colors and/or patterns – instructing the user to find a certain graphic element, tab color, or tab pattern. In other embodiments, the indicia **26** may comprise a code, words, instructions, letters, numbers, or combinations of letters and numbers. In an embodiment, the indicia are scrambled. In an embodiment, the indicia **26** associated with the decoy tabs **80** are each different from each other. In an embodiment, if more than one tab **70** is presented, the indicia **26** associated with each tab **70** is the same. The indicia **26** may be positioned on or adjacent the tabs **70** and decoy tabs **80**.

[0069] In an embodiment, the label **15** additionally comprises directions **28**. The directions may inform the consumer as to which tab(s) are the removable tab(s) **70** which should be used to open the package **10**. In this regard, the consumer also understands which tab(s) are the decoy tabs **80** (i.e. those that are not the tab(s) **70**). The directions **28** may tell the consumer to find a particular code, word, letter combination, letter/number combination, or the like. The directions **28** may provide an example tab which should match tab **70**. The directions **28** may present a puzzle or

question and the tab(s) **70** may provide the correct answer, in an embodiment. Any directions **28** which inform a consumer as to which tab is the tab **70**, the opening tab, is contemplated herein. The directions **28** and corresponding matching/unmatching indicia **26** provide yet another child resistance feature of the invention. The directions **28** may comprise words and/or sentences that a child cannot read, a puzzle that a child cannot solve, and/or the indicia **26** may comprise confusing letter/number combinations that a child cannot make sense of, further limiting the likelihood that a child will be able to access the package contents.

[0070] In an embodiment, the directions **28** are presented on the portion of the label **15** which covers the access point **35**. In another embodiment, the directions **28** are presented on the resealable flap portion **18**. In an embodiment, the directions **28** are intermixed with the packaging logos and graphics to further camouflage them from a child.

[0071] In an embodiment, the packaging structure and/or the label **15** of the invention may comprise any flexible packaging known in the art, including but not limited to, polymer films, metalized polymer films, papers, metal foils, polyester films, polyolefin films, polyethylene terephthalate (PET), oriented polypropylene (OPP), metalized polyester (MPET), any combination thereof, or any other suitable film known in the art. In various embodiments, the packaging structure and/or the label **15** may comprise multiple layers. In various embodiments, the packaging structure and/or the label **15** may comprise a multi-layer film. In an embodiment, the packaging structure and/or the label comprises a pre-printed film.

[0072] In certain embodiments, the label **15** of the invention may comprise a barrier layer, providing a barrier against the passage of oxygen and/or moisture. In other embodiments, the label **15** may additionally comprise one or more metallization layers or foil layers.

[0073] In an embodiment, the package **10** may additionally comprise tamper-evident indicators. The tamper evident indicators may comprise any form known in the art used to indicate whether a package has been previously opened or whether the integrity of the package has been compromised. In an embodiment, the tamper evident indicator may provide an uninterrupted film area that breaks upon opening of the package **10** and remains on the package **10** after it is opened. In another embodiment, the tamper evident indicator may comprise a paper sticker which is permanently adhered over a portion of the label **15**, breaks upon opening of the package **10**, and remains on the package **10** after it is opened for evidence of tampering. In an embodiment, the tamper evident indicators may include an area of weakness created, for example, by a scored, perforated, or thinned line or by forming the tamper evident indicator out of a highly oriented material that has a tendency to split along a break line. In an embodiment, the invention utilizes tamper-evident indicators as more fully described in U.S. Patent Application No. 15/017,743 to Gagne, which is incorporated by reference herein in its entirety.

[0074] In a particular embodiment, the tamper evidence of the package may be indicated due to a misalignment of graphics. For example, the packaging graphics may be designed such that once the package is opened, it is very difficult, if not impossible, to completely realign the graphics upon reclose of the package. For instance, the

graphics may stretch or become distorted in one or more areas, or along the cut line, upon opening of the package. In such cases, if the graphics are misaligned, a user is aware that the package has been opened.

[0075] In an embodiment, the package **10** may define multiple cavities for storage of products. In this embodiment, for example, there may be separate cavities on the left and right side of the package **10**, optionally separated by an internal divider.

[0076] In an embodiment, the invention comprises a discrete label which may be separately applied to a packaging structure. FIG. 7 illustrates an embodiment of the discrete label. In this embodiment, cut line **120** defines the perimeter of the discrete label. Recessed portion **190** is shown in the connecting portion of cut line **125**, which defines the peelable flap **118**. In this embodiment, the label **115** is shown as adhered to a rollstock packaging structure **110**, forming a laminate **100**. In an embodiment, the label **115** and rollstock **110** are laminated using adhesive (permanent, PSA, or a combination thereof), before or after disposing the cut lines in the various film structures.

[0077] In this embodiment, cut line **120** may be disposed through both the label **115** and the rollstock **110**. However, in an embodiment, the rollstock layer **110** may be replaced with a disposable liner and the cut line **120** may be disposed through only the label **115**. In another embodiment, the label **115** may be a single ply and cut line **120** may, in an embodiment, comprise perforations to be separated before adherence to a package.

[0078] In this embodiment, the resealable flap portion **118** is defined by cut line **125** and ends in j-hooks **160**, as shown in FIG. 2A. The resealable flap portion **118** extends

from the center of the label **115** outwardly, over the fold lines **130**. The fold lines **130** represent the fold lines of the final package **10**. Cut line **140** is disposed in the rollstock **110** and does not, in an embodiment, continue through or into the label **115**. Tabs **170** are shown in cross-hatching and decoy tabs **180** are shown in single hatching.

[0079] After the scoring, cutting, perforating, and adhering steps have occurred, the discrete label **115** may be removed from the skeleton and/or liner and adhered (using separate adhesive or using the adhesive applied during manufacture) to a package. This may occur in a separate location, using separate equipment, if desired.

[0080] FIG. 8 illustrates an alternate embodiment of the invention wherein the label is formed as an integral part of the packaging. In this embodiment, the packaging structure may comprise a multi-layer film laminate. The laminate may comprise an inner structure (or lower structure) and an outer structure (or upper structure). The outer structure may be adhesively joined to the inner structure before or after die cuts and/or scoring. A score line **125** in the outer structure may define an outer opening, described herein as the resealable flap **118**.

[0081] In this embodiment, the inner structure may additionally comprise a score line **140**. The inner structure score line **140** may be generally parallel to the score line **125** defining the resealable flap. In other embodiment, the inner score line **140** may be similarly shaped but not parallel to the outer score line **125**. In still other embodiments, the score lines **140** and **125** may be differently shaped. The inner structure score line **140** may be spaced inwardly of the outer structure score line **125** so as to define an inner opening portion **135**, which is of smaller area than the outer opening portion **118**.

The inner structure score line **140** can be a closed shape such as a rectangle, oval, or ellipse, or can be generally U-shaped like the outer structure score line.

[0082] In an embodiment, a marginal region of the outer opening portion extends beyond the edge of the inner opening portion. PSA is, in an embodiment, disposed in this marginal region, between the inner and outer structures (see Fig. 5B, PSA **595**). The PSA may be disposed on the underside of the outer structure or the upper side of the inner structure. In this embodiment, the PSA may be applied to the outer structure and may remain on the outer structure upon opening, but it is also within the scope of the invention to apply the PSA to the inner structure and to remain on the inner structure upon opening.

[0083] When the outer opening portion **118** is detached from the outer structure along the outer structure score line **125** and is peeled back, the inner opening portion **135** may remain affixed to the outer opening portion and come with it, thereby creating an opening in the top surface of the package as defined by the inner structure score line. In an alternate embodiment, the inner opening portion **135** is created during the cutting portion of the manufacturing process and the inner layer contains an aperture **135**. In either case, the outer and inner opening portions form a flap **118** that remains attached along a hinge line **23** defined between the free ends **160** of the two legs of the U-shaped score lines **125**.

[0084] FIGS. 2A-2C illustrate alternate embodiments of the inventive laminate **200**. In the embodiment set forth in FIG. 3A, the tabs **270** are shown in dissimilar locations on the side panels of the label **220**. For example, the tab **270** on the left side of the laminate is shown in the uppermost position while the tab **270** on the right side of the

laminate is shown in the middle position of the laminate. In other examples, the tabs **270** may not be vertically aligned with one another on opposite sides of the package. Any position of tabs **270** is contemplated herein. This varied tab **270** location may add complexity and confusion to the removal process, aiding in the child resistant nature of the package **10**. Decoy tabs **280**, the free end **260** of the outer die cut, inner die cut **240**, and fold lines **230** are also shown in FIGS. 2A-2C.

[0085] FIG. 3 shows another alternate embodiment of the laminate **300**. In this embodiment, the decoy tabs **380** are illustrated in line with, but outside the position of the opening tabs **370**. In this embodiment, the decoy tabs **380** may comprise cut lines, but may have j-hook ends such that they do not connect with the resealable flap portion **318** and cannot aid in removal of the resealable flap portion **318**. Alternatively, the decoy tabs **380** may be merely visual displays or printed matter. The free end **360** of the outer die cut, inner die cut **340**, and fold lines **330** are also shown in FIG. 3.

[0086] FIG. 4A illustrates still another embodiment of the laminate **400**. In this embodiment, decoy tabs **480** are shown in line with, and both inside and outside the position of the opening tabs **470**. In this embodiment, the decoy tabs **480** may comprise printed graphics and may not comprise cut lines or may comprise cut lines that do not connect with the resealable flap portion **418**. The free end **460** of the outer die cut, inner die cut **440**, and fold lines **430** are also shown in FIG. 4A-4B.

[0087] FIG. 4B illustrates yet another embodiment of the laminate **400**. In this embodiment, the tabs **470** and decoy tabs **480** each have associated codes **426**. The packaging may, in this embodiment, have displayed directions **428** which indicate which code matches the removable tabs **470**. The tabs **470** and decoy tabs **480** may also

comprise colors, shapes, lines, and/or patterns and the directions **428** may indicate, based upon those colors, shapes, lines, and/or patterns, which are the tabs **470** and the decoy tabs **480**.

[0088] In embodiments wherein the decoy tabs **80** are printed graphics, such printing may be disposed on the outside of the label **15**, the inner surface of the label **15**, or the outer surface of the packaging structure. The printed decoy tabs **80** may complement or be integral with any labeling or printing ordinarily presented on the package.

[0089] FIGS. 5A and 5B illustrate an embodiment of the invention wherein the package **500** is shown in a closed (FIG. 5A) and open (FIG. 5B) configuration. In this embodiment, PSA **595** is visible on the underside of the resealable flap portion **518** (see FIG. 5B). Additionally, the access point **535**, defined by cut line **540**, is easily viewable. The cover portion **585**, that is, the portion which covers the access point **535**, is shown as well. In some embodiments, the cover portion **585** may be a PSA-free portion of the outer film. In other embodiments, the cover portion **585** may be a part of the inner film which separates from the remainder of the inner film and remains attached to the flap portion **518** when the flap portion **518** is pulled away from the package **500**.

[0090] The recessed portion **590** of flap portion **518** is shown, as is the free end **560** of the leg portion of cut line **525**, which defines the flap portion **518**. As is visible, the tabs **570** are visually aligned with the decoy tabs **580**.

[0091] The package **510** is reclosable by re-attaching the resealable flap portion **518** to the surface **592** of the front panel **532** to restore the package to a closed condition as shown in FIG. 5A. The PSA **595** will re-adhere the resealable flap portion **518** to the front panel **532**. Additionally, the tabs **570** can be at least partially re-attached to the

side panels **533** of the package **510**, using the PSA **595**. In this manner, the package is resealed and is, again, child resistant. This process may be repeated as desired.

[0092] In this embodiment, a label may be applied to a packaging structure as a discrete separate label (shown by cut lines **520**). Alternatively, however, the flap portion **518** shown in FIG. 5A and 5B could be formed integrally with the packaging structure, in which case cut lines **520** would not be displayed but the structure would otherwise look the same.

[0093] FIG. 6 illustrates another alternate embodiment of the invention. In this embodiment, the package **600** comprises a stand-up pouch. The access point **635** is disposed in the front wall **632**, defined by cut line **640**. The resealable flap **618** is defined by cut line **625**, ending at the free ends **660**. The opening/reclose features operate in a manner similar to that described above. Again, the label shown in FIG. 6 could be applied as a discrete label defined by cut lines **620** or as integral with the packaging structure, in which case cut lines **620** would not be present. As shown, the tab **670** is disposed above, but vertically aligned with the decoy tabs **680**, disposed on the side panel **633**.

[0094] FIG. 9 shows yet another embodiment of the invention. In this embodiment, the tab **970** is not continuous with the flap portion **918** which is defined by cut line **925**. Instead, there is an interruption **942** between each end of tab **970** and cut line **925**. The interruption **942** provides further evidence of tampering with the package. That is, if the interruptions **942** are broken, the package has been opened. In this embodiment, the interruptions **942** are thin film segments that are designed to remain attached until the package is opened. Upon opening of the package, the interruptions **942** stretch until

they break, connecting the cut line **942** defining tab **970** with cut line **925** defining the flap portion **918**. In this embodiment, an interruption **942** may be present on one or both ends of the tab **970**. In Fig. 9, an outer edge **943** of the tab **970** is deadened or is adhesive-free.

[0095] In various embodiments shown in FIGS. 10-12, a packaging structure is shown. In these embodiments, the packaging may comprise an integral peelable flap or may comprise a label to be separately applied to a packaging structure. In an embodiment, the peelable flap portion **1018** may have one tab **1070** and multiple decoy tabs **1080**. The tab **1070** and one or more decoy tabs **1080** may be disposed on a side panel **1033** of the packaging structure. The opposite side panel **1033** may comprise only decoy tabs **1080**, in an embodiment. In an embodiment, the instructions **1028** for opening the package may be presented on the top panel or any other panel of the structure. In an embodiment, the instructions **1028** are on a panel which is different from any panel which contains a portion of the peelable flap portion **1018**.

[0096] In an embodiment, the packaging structure comprises a deadened or adhesive-free area **1001** beneath at least a portion of the tab **1070**. The adhesive-free area **1001** may comprise a variety of shapes and configurations. In an embodiment, the adhesive-free area **1001** extends from within the interior of the tab **1070** to beyond the cut line which defines the edge of the tab **1070**. In an embodiment, the entire area **1001** may comprise a pressure sensitive adhesive ("PSA") and there may not be an adhesive-free area.

[0097] In an embodiment, the packaging structure contains PSA area **1006**. Any PSA known in the art may be utilized in this embodiment. In an embodiment, the PSA

area **1006** is disposed on at least the front panel **1032** and at least partially on one of the side panels **1033** of the structure. In this embodiment, one of the film layers may be flood coated with PSA in the PSA area **1006** and subsequently deadened in the adhesive-free area **1001**. In another embodiment, the PSA may be pattern-applied to avoid the adhesive-free area **1001**. In another embodiment, a wax, oil, or other component may be disposed in the adhesive-free area **1001** prior to application of the adhesive to avoid adherence of the adhesive in that area. In an embodiment, the packaging structure contains a permanent adhesive area **1004**. Any permanent adhesive known in the art may be utilized in this embodiment. The permanent adhesive area **1004** may be disposed on or around various fold lines, for example, on or around fold line **1031**, between the front panel **1032** and the top panel **1034**. In an embodiment, permanent adhesive **1004** is disposed in a perimeter around the peelable flap portion **1018**.

[0098] In an embodiment, the adhesive-free area **1001** extends from within the interior of the tab **1070** to substantially the end of the PSA area **1006**. In an embodiment, the adhesive-free area **1001** extends from within the interior of the tab **1070** to substantially the beginning of the permanent adhesive area **1004**.

[0099] In an embodiment, the adhesive-free zone **1001** extends from the side panel **1033** at least partially into the front panel **1032**. In an embodiment, the adhesive-free zone **1001** is disposed only on the side panel **1033** and ends at or substantially near the fold line **1030** between the side panel **1033** and the front panel **1032**. In an embodiment, the adhesive-free zone **1001** directs the tearing of the tab **1070** along the designated cut lines **1025**.

[00100] In an embodiment, the adhesive-free zone **1001** is generally bell shaped or plunger shaped, with the handle **1003** of the bell or plunger extending at least partially beyond the cut line which defines the edge of the tab **1070**. In this embodiment, the bell or plunger portion **1005** of the adhesive-free zone **1001** is disposed on the side panel **1033** and extends at least partially into the front panel **1032**. In an embodiment, the handle **1003** of the adhesive-free zone **1001** has an extended, narrower shape than the plunger portion **1005** of the adhesive-free zone **1001**. In an embodiment, the handle **1003** of the adhesive-free zone **1001** has a curved distal portion **1007**, opposite the plunger portion **1005** of the adhesive-free zone **1001**. In an embodiment, the plunger portion **1005** of the adhesive-free zone **1001** has a bell-shaped, curved perimeter which extends toward the front panel **1032**. In an embodiment, the base **1009** of the plunger portion **1005**, opposite the handle **1003**, comprises a straight cut line (see FIGS. 11-12). As shown in FIG. 10, however, the base **1009** of the plunger portion **1005** may have a curvature and may, in an embodiment, have a concave curvature.

[00101] As shown in FIGS. 10-11, the cut line **1025** which defines the peelable flap portion **1018** may have a different length on either side of the recessed portion **1090**. Alternatively, the cut line **1025** which defines the peelable flap portion **1018** may have a different curvature or disposition on either side of the recessed portion **1090**. For example, the segment of the cut line **1025** which is left of the recessed portion **1090** may be disposed closer to the fold line **1031** between the front panel **1032** and the top panel **1034** than is the segment of the cut line **1025** which is right of the recessed portion **1090**, looking at the package from the front.

[00102] In an embodiment, the cut line **1025** is disposed differently based upon the location of the tab **1070** versus the locations of the decoy tab(s) **1080**. Thus, the segment of the cut line **1025** which is between the tab **1070** and the recessed portion **1090** may be disposed closer to the fold line **1031** between the front panel **1032** and the top panel **1034** than is the segment of the cut line **1025** which is on the other side of the recessed portion **1090**. Similarly, the segment of the cut line **1025** which is between the tab **1070** and the recessed portion **1090** may have a different radius of curvature, location, or disposition than the segment of the cut line **1025** which is on the other side of the recessed portion **1090**. That is, the peelable label **1018** may be asymmetrical in one or more ways.

[00103] In an embodiment, the segment of the cut line **1025** which is disposed between the tab **1070** and its nearest free end **1060** may be angled and/or curved. In some embodiments, providing a straight or substantially straight cut line **1025** between the tab **1070** and its nearest free end **1060** causes the film to separate slightly at the location of the cut line **1025** or to be detectable by touch. The inventors have found that utilizing a curved or angled cut line **1025**, between the tab **1070** and its nearest free end **1060** prevents unwanted separation or tactile detection at the location of the cut line **1025**. This aids in the child safety features, as children cannot easily find the cut line **1025** using the sense of touch.

[00104] In an embodiment, the segment of the cut line **1025** which is disposed between the tab **1070** and its nearest free end **1060** may be angled and/or curved both upwardly and downwardly between the tab **1070** and the free end **1060**. In this embodiment, the tab **1070** may be defined by a semi-circular, semi-ovular, or semi-

elliptical perimeter, or any other curved perimeter shape (for example, a partial circle which is less than half of a circle) which may provide a grippable tab. In an embodiment, the tab **1070** may be a convex configuration. At the edge **1008** of the tab **1070** nearest the free end **1060** of the cut line **1025**, the cut line **1025** may curve concavely. Traveling toward the free end **1060** of the cut line **1025**, the cut line **1025** may then extend outwardly, away from the fold line **1030**, in a curved or angled manner. One or more interrupted areas **1024** may be presented along the cut line **1025**, between the tab **1070** and its nearest free end **1060**. In an embodiment, the curvature or angled nature of the cut line **1025**, as discussed herein, may reduce the number of interrupted areas **1024** that are utilized in the packaging. For example, the interrupted areas **1024** may serve not only as tamper evidence features, but may also aid in allowing the film near the cut line **1025** to lay flat. Creating variations (angles and/or curvatures) in the cut line **1025** may allow the packaging to lay flat at or near the cut line **1025** with fewer interrupted areas **1024**.

[00105] In an embodiment, only one interrupted area **1024** is disposed between the tab **1070** and its nearest free end **1060**. In this embodiment, the cut line **1025** may curve concavely near the edge **1008** of the tab **1070** nearest the free end **1060**. The cut line **1025** may then extend outwardly, away from the fold line **1030**, in a curved or angled manner, toward the interrupted area **1024**. Past the interrupted area **1024**, the cut line **1025** may then extend inwardly, toward from the fold line **1030**, in a curved or angled manner, until it reaches the free end **1060**. In this embodiment, there is no portion of the cut line **1025**, between the tab **1070** and its nearest free end **1060**, which is straight and/or parallel to the fold line **1030**.

[00106] FIGS. 13A-13F illustrate a variety of interrupted areas **1324** which may be utilized in combination with any of the embodiments discussed herein. The interrupted areas **1324** shown in FIG. 13 each comprise a small j-hook.

[00107] FIG. 12 illustrates a variety of adhesive-free areas **1001** which are envisioned by the present invention. In these embodiments, the adhesive-free area **1001** may be bell- or plunger-shaped, as discussed above. Alternatively, the adhesive-free area **1001** may be an elongated oval (shown in FIGS. 12A-12C), circle, or ellipse. In some embodiment, the two sides (**1011**, **1022**) of the plunger portion **1005** are not symmetrical.

[00108] In some embodiments, the width of the handle portion **1003** of the adhesive-free area **1001** (or the entirety of the adhesive-free area **1001** as in FIGS. 12A-12C) is narrower than the width of the tab **1070**. In an embodiment, the width of the tab **1070** may be substantially greater than the width of the handle portion **1003** of the adhesive-free area **1001**. For example, the width of the handle portion **1003** of the adhesive-free area **1001** may be $1/8^{\text{th}}$, $1/6^{\text{th}}$, $1/4^{\text{th}}$, $1/3^{\text{rd}}$, or $1/2$ the width of the tab **1070**. In an embodiment, the width of the handle portion **1003** of the adhesive-free area **1001** may be between $1/16$ inches and $3/16$ inches. In an embodiment, the adhesive-free area **1001** is centered within the tab **1070**. In an embodiment, the width of the handle portion **1003** of the adhesive-free area **1001** is designed to be small enough to not be obvious to children, but large enough to fit a fingernail beneath to pull the tab away from the packaging structure, and intuitive enough for senior citizens to be able to open the package. In an embodiment, handle portion **1003** of the adhesive-free area **1001** is designed as the initial access point into the package.

[00109] FIGS. 12D-12L illustrate variations on the bell- or plunger-shaped adhesive-free area **1001**. The plunger portion **1005** of the adhesive-free zone **1001** may have a variety of widths and sizes. The plunger portion **1005** of the adhesive-free zone **1001** may extend nearly to the edge of the tab 1070, such as is shown in FIGS. 12D through 12F) or may be more centrally-located, such as is shown in FIGS. 12J through 12L.

[00110] In an embodiment, the curvature or angle on one side of the plunger portion **1005** may be different from the curvature or angle on the other side of the plunger portion **1005**. The section of the plunger portion **1005** which is disposed nearest the handle **1007** may be generally convex. The section of the plunger portion **1005** which is disposed nearest the handle **1007** may be similar in configuration to the tab **1007**. The plunger portion **1005** may extend from its convex curve near the handle **1007** toward the base **1009** of the adhesive-free zone **1001**. The perimeter section of the plunger portion **1005** which is disposed closest to the fold line **1031** between the front panel **1032** and the top panel **1034**, the first side **1011**, may taper from the convex curve to become a straight or nearly straight line which ends at the base **1009**. On the other hand, the perimeter section of the plunger portion **1005** which is disposed furthest from the fold line **1031** between the front panel **1032** and the top panel **1034**, the second side **1012**, may have a different angle, curvature, shape, or configuration from that of the first side **1011** of the plunger portion **1005**. Using the fold line **1031** between the front panel **1032** and the top panel **1034** as a zero angle, the first side **1011** of the plunger portion **1005** may also have a zero angle, but the second side **1012** of the plunger portion **1005** may have an angle which is greater than zero. In an embodiment, the first side **1011** of the plunger portion **1005** has a non-zero angle and the second side **1012** of the plunger

portion **1005** has a non-zero angle which is greater than that of the first side **1011**. In an embodiment, the second side **1012** of the plunger portion **1005** may have a concave portion, as shown in FIG. 10.

[00111] In an embodiment, the varied angles and curvatures of the first side **1011** and the second side **1012** of the plunger portion **1005** aid in directing the peelable flap portion **1018** as it is opened. That is, the greater angle on the second side **1012** of the plunger portion directs the tab **1070** and peelable flap **1018** in general to open toward the access point **1035**.

[00112] It should be noted that the term “cut line” as used herein may refer to a complete cutting through the thickness of one or more layers, a partial cutting through of the thickness of such layer(s), allowing the layer(s) to be severed along the score line, or a multiple perforations through the thickness of one or more layers. In an embodiment, the cut line extends into an adhesive layer between two film layers.

[00113] In certain embodiments, the packaging described herein is formed by enveloping the contents in a packaging structure which has an integral peelable flap portion as described herein. Alternatively, however, it is within the scope of the invention to employ the label **15** as a lidding stock for forming flexible lids that can be secured (e.g., by heat-sealing or the like) to a flange of a tray or other container that contains the contents. Likewise, the label **15** may be applied to a pillow pouch, can end, or any other container or packaging structure known in the art. In this manner, the lid includes a built-in opening and reclose feature as previously described.

[00114] For example, FIG. 14 illustrates an exemplary pillow pouch **1400** which has a cut line **1425** defining the peelable flap portion **1418**. The peelable flap **1418** comprises

a tab **1470** and, in this example, three decoy tabs **1480**. Any number of decoy tabs may be utilized. The figure also illustrates the code **1428** and the undercut inner cut line **1440**. Because the pillow pouch does not have sidewalls and top and bottom walls, the entire peelable flap portion **1418**, tab **1470**, and cut line **1425** may be disposed on the front panel of the package. The pillow pouch **1400** may have an integral peelable flap portion **1418** or a discrete label may be applied to the pillow pouch to provide the child resistant packaging.

[00115] While the invention is described herein as having decoy tabs, it should be understood that the decoy tabs may be omitted. For example, in some embodiments, the code may indicate that the pull tab is located in a particular location of the graphical display – such as on the shoe of the character shown on the packaging (i.e. “Pull Tab is Ralphie’s Left Shoe”), in a particular color range (i.e. “Pull Tab is the Blue Oval”), or within wording (i.e. “Pull Tab is the “O” in the Word Olive”). Thus, the invention covers embodiments wherein the pull tab is disguised or camouflaged by the packaging graphics and would not be readily identifiable but for the code or instructions provided on the packaging. In still another embodiment, a misalignment of graphics provides an indication of the pull tab. For example, if all of the graphics in the packaging are aligned but for one particular area, that may be an indicator that the functioning pull tab is located in that position. In an embodiment, the code/instructions are always located in the same position. In an embodiment, the functioning pull tab is always located in the same position, allowing users to learn and become more comfortable with opening the packaging after repeated use.

[00116] While the packaging and labels discussed herein are referred to as having two layers, an inner layer and an outer layer, any number of film layers may be utilized. For example, in an embodiment, the inner layer may comprise a plurality of layers and/or the outer layer may comprise a plurality of layers. For example, one or both of the inner and outer layers may comprise two layers: oriented polypropylene (OPP) and polyethylene (PE). The various layers may be adhered or co-extruded. In an embodiment, the inventive packaging comprises three layers or plies.

[00117] **Method of Manufacture**

[00118] **Discrete Label**

[00119] In an embodiment, a discrete label of the invention (shown in FIG. 4B, for example) is manufactured according to the method described herein. In this embodiment a roll of film may be advanced from a supply roll by suitable web driving and handling equipment to an optional print station comprising a printing apparatus, such as a rotogravure printer or the like, for printing tabs, decoy tabs, graphics and/or indicia on the film by applying inks to a surface of the film. In an embodiment, the film may be printed on its inner or outer surface. The printing may comprise the various indicia **426** and directions **428** of the invention. The printing may also comprise colors, shapes, lines, and/or patterns which indicate the tabs **470** and the decoy tabs **480**.

[00120] Prior to printing the film in the print station, the surface of the film can be treated by a corona discharge or flame treatment apparatus to render the surface more receptive to the inks and/or to render the surface more readily bondable to the PSA that is subsequently applied to the surface as described below. Alternatively, the film can

have already been so treated prior to being wound into the supply roll, such that the treatment apparatus is unnecessary.

[00121] The film is then advanced to an adhesive application station at which an adhesive is applied to the film. In an embodiment, the adhesive is a PSA and is applied in a predetermined pattern, optionally avoiding (leaving adhesive-free) the underside of the resealable flap portion **418** and/or the tabs **470**. In alternative embodiments, the film may be flood-coated with PSA onto the entire surface of the film and the PSA may later be deadened or deactivated in regions (noted above) which are designed to be adhesive-free. In some embodiments, a combination of permanent and pressure sensitive adhesive may be pattern applied or flood coated and deadened/deactivated.

[00122] The adhesive application station can comprise any suitable device capable of accurately applying the adhesive to the film in the desired pattern or as flood coated. For example, the adhesive application station can comprise a gravure roll that picks up the adhesive from a reservoir on the outer surface of the roll such that the adhesive fills one or more recessed areas in the surface. A doctor blade can scrape off excess adhesive so that it remains essentially only in the recessed area(s). The film is then contacted by the gravure roll to apply the adhesive. A backing roll may provide support on the opposite side of the film. After application of the adhesive, the film may be advanced to a dryer such as an oven or the like, to dry or partially dry the adhesive.

[00123] After application of the adhesive, the film may be advanced to a station for application of a backing or release liner. The film may be passed through a nip along with a backing or release liner that is advanced from its own supply roll, and the film and release liner may be affixed to each other. The release liner may be coextensive with

the film - i.e., the width of the release liner is substantially equal to the width of the film and the longitudinal edges of the release liner substantially coincide with the longitudinal edges of the film. The resulting lined film may then be advanced to a reel-up where it is wound into a roll for subsequent processing. Alternatively, it is possible for the reel-up operation to be omitted, such that the laminate is directly advanced.

[00124] In an embodiment, the lined film is then advanced to a scoring station at which score line **425** (FIG. 4B) is formed. The scoring station can comprise a laser or a mechanical cutting die. Optionally, one or more decoy tabs may be scored as discontinuous with the score line **425**.

[00125] After the scoring operation, the lined film can be sent to a reel-up and wound into a roll for subsequent processing. The lined film can alternatively be cut into a plurality of labels. The labels may later be applied to a package by removing the liner/backing and adhering the labels to a packaging structure or package in an off-line process.

[00126] Integral Laminated Packaging Structure

[00127] In an embodiment, an integral laminated packaging structure and label of the invention (shown in FIG. 8) is manufactured according to the method described herein. In this embodiment a first roll of film may be advanced from a first supply roll to an optional print station comprising a printing apparatus for printing tabs, decoy tabs, graphics and/or indicia on the film by applying inks to a surface of the first film. In an embodiment, the film may be printed on its inner or outer surface, as described above.

[00128] Prior to printing the first film in the print station, the surface of the first film can be treated by corona discharge or flame treatment, as noted above. The first film may

then be advanced to an adhesive application station at which an adhesive is applied to the first film, as described above. After application of the adhesive, the film may be advanced to a dryer such as an oven or the like, to dry or partially dry the adhesive.

[00129] Optionally, the first film may then be advanced to a second adhesive application station at which a second adhesive, possibly a permanent laminating adhesive, may be applied to the film in a pattern. If the film includes an adhesive-free region as previously noted, the pattern of the second adhesive also does not cover the adhesive-free region. A suitable adhesive application device can be a gravure roll of the type previously described. After the optional application of the second adhesive, the film may be advanced to a second dryer such as an oven or the like.

[00130] After application of the adhesive, the first film may then be advanced to a laminating station, comprising a pair of rolls forming a nip therebetween. The first film is passed through the nip along with a second structure that is advanced from its own supply roll. The second structure may comprise a flexible film or any other packaging structure as described herein. The first film and the second structure are then laminated to each other. The second structure may be coextensive with the first film, as noted above. The resulting laminate may then be advanced to a reel-up where it is wound into a roll for subsequent processing. Alternatively, it is possible for the reel-up operation to be omitted, such that the laminate is directly advanced.

[00131] In an embodiment, the lined film is then advanced to a scoring station at which a first score line **125** is formed. The scoring station can comprise a laser or a mechanical cutting die. The first score line **125** may extend substantially through the thickness of the first film, but preferably does not extend to any substantial extent into

the second structure. Optionally, one or more decoy tabs may be at least partially scored. In this embodiment, the decoy tabs would not be continuous with the score line **125**.

[00132] Optionally, the laminate is then advanced to a second scoring station at which a second, or inner, score line **140** is undercut and formed through the thickness of the second structure. The second score line **140** extends substantially through the thickness of the second structure, but preferably does not extend to any substantial extent into the first film. The second score line **140** is spaced inwardly of the first score line **125** so as to define an access point **135** of smaller area than the resealable flap portion **118**. The portion of the second structure which covers access point **135** may be adhered to the resealable flap portion **118** (by an adhesive), such that both portions are lifted together when opening the package. Alternatively, the portion of the second structure which covers access point **135** may be removed from the laminate and discarded after cutting second score line **140**, such that when resealable flap portion **118** is lifted from the package, access point **135** is presented. After the scoring operations, the laminate can be processed as set forth above.

[00133] These and other modifications and variations to the present invention may be practiced by those of ordinary skill in the art, without departing from the spirit and scope of the present invention, which is more particularly set forth in the appended claims. In addition, it should be understood that aspects of the various embodiments may be interchanged in whole or in part. Furthermore, those of ordinary skill in the art will appreciate that the foregoing description is by way of example only, and is not intended to limit the invention so further described in such appended claims. Therefore, the spirit

and scope of the appended claims should not be limited to the description of the versions contained therein.

What is claimed is:

1. A child resistant laminate package comprising a first panel and at least two second panels joined to the first panel, wherein the second panels are disposed in a plane which is different from the plane of the first panel, and wherein the first and at least two second panels comprise:
 - an inner layer;
 - an outer layer;
 - an adhesive layer disposed between the inner layer and the outer layer;
 - wherein the outer film layer is scored to form at least one peelable flap portion comprising at least one tab which is continuous with the peelable flap portion, wherein the at least one tab is disposed at least partially on one of the at least two second panels;
 - wherein the inner layer is scored to form at least one access point into the package, wherein the at least one access point is disposed at least partially within the location of the peelable flap portion; and
 - wherein the access point is disposed at least partially in the first panel.
2. The package of claim 1, wherein the adhesive layer at least partially comprises pressure sensitive adhesive.
3. The package of claim 2, wherein the peelable flap portion is resealable to the inner layer via the pressure sensitive adhesive layer.
4. The package of claim 2, wherein the pressure sensitive adhesive layer is disposed on the lower surface of the outer film.
5. The package of claim 1, wherein at least one decoy tab is disposed on at least one of the second panels such that the at least one decoy tab is not scoredly continuous with the peelable flap.

6. The package of claim 5, wherein the at least one decoy tab is visually displayed but is not scored.
7. The package of claim 5, wherein the perimeter of the at least one decoy tab is at least partially scored.
8. The package of claim 5, wherein the at least one decoy tab is disposed adjacent the at least one tab.
9. The package of claim 5, wherein the at least one tab and the at least one decoy tab contain indicia and wherein the indicia associated with the at least one tab is different from the indicia associated with the at least one decoy tab.
10. The package of claim 5, wherein the at least one tab and the at least one decoy tab are of substantially the same shape and size.
11. The package of claim 5, wherein the at least one tab and the at least one decoy tab are positioned in substantially the same configuration.
12. The package of claim 1, wherein the wherein the score in the inner layer is formed inwardly of the score in the outer layer.
13. The package of claim 1, wherein the at least one tab is at least partially not adhered to the inner layer.
14. The package of claim 1, wherein the perimeter of the peelable flap portion comprises a connecting portion and two leg portions and wherein the leg portions are disposed at least partially on the second panels of the package.

15. The package of claim 14 wherein the connecting portion of the peelable flap portion perimeter comprises a recessed portion which extends toward a hinge line disposed between the free ends of the leg portions.

16. The package of claim 1, wherein the perimeter of the peelable flap portion comprises a connecting portion and two leg portions and wherein the leg portions comprise at least one interrupted area.

17. The package of claim 1, wherein the second panels are disposed on opposite sides of the first panel.

18. A child resistant laminate package comprising a first panel and at least two second panels joined to the first panel, wherein the second panels are disposed in a plane which is different from the plane of the first panel, and wherein the first and at least two second panels comprise:

an inner layer;

an outer layer;

an adhesive layer disposed between the inner layer and the outer layer;

wherein the outer film layer is scored to form at least one peelable flap portion comprising at least one tab which is continuous with the peelable flap portion, wherein the at least one tab is disposed on one of the at least two second panels;

wherein the inner layer is scored to form at least one access point into the package, wherein the at least one access point is disposed at least partially within the location of the peelable flap portion;

wherein the access point is disposed in the first panel; and

wherein the perimeter of the peelable flap portion comprises a connecting portion and two leg portions and wherein a first leg portion is disposed substantially on one second panel of the package and a second leg portion is disposed substantially on a different second panel of the package.

19. A child resistant laminate package comprising a first panel and at least two second panels joined to the first panel, wherein the second panels are disposed in a plane which is different from the plane of the first panel, and wherein the first and at least two second panels comprise:

an inner layer;

an outer layer;

an adhesive layer disposed between the inner layer and the outer layer;

wherein the outer film layer is scored to form at least one peelable flap portion comprising at least one tab which is continuous with the peelable flap portion, wherein the at least one tab is disposed at least partially on one of the at least two second panels;

wherein the inner layer is scored to form at least one access point into the package, wherein the at least one access point is disposed at least partially within the location of the peelable flap portion;

wherein the access point is disposed at least partially in the first panel;

and

wherein at least one decoy tab is disposed on the at least one second panel such that the decoy tab is not scoredly continuous with the peelable flap.

20. A method for making a child resistant package comprising:

laminating an outer film layer to an inner film layer to form a laminate;

forming an outer die cut in the outer film layer to define a peripheral edge of a peelable flap portion and at least one tab which is continuous with the peelable flap portion;

forming an inner die cut in the inner film layer to define a location of an opening, wherein the inner die cut is formed inwardly of the outer die cut;

printing at least one of the inner film and the outer film, wherein the print comprises at least one decoy tab which is visually similar to the at least one tab; and

forming the laminate into a package having a first panel and at least two second panels joined to the first panel, wherein the second panels are disposed in a plane

which is different from the plane of the first panel and the at least one tab and the at least one decoy tab is disposed on at least one of the second panels of the package.

21. A method for making a child resistant package comprising:

laminating an outer film layer to an inner film layer to form a laminate;

forming a first outer die cut in the outer film layer to define a peripheral edge of a peelable flap portion and at least one tab which is continuous with the peelable flap portion;

forming at least one additional outer die cut in the outer film layer to define at least one decoy tab, wherein the decoy tab is not continuous with the peelable flap portion;

forming an inner die cut in the inner film layer to define a location of an opening of the package, wherein the inner die cut is formed inwardly of the first outer die cut; and

forming the laminate into a package having a front panel and at least two side panels such that the at least one tab and the at least one decoy tab are disposed on at least one of the side panels of the package.

22. The method of claim 21, wherein the perimeter of the peelable flap portion comprises a connecting portion and two leg portions and wherein the leg portions are disposed at least partially on the side panels of the package.

23. A method for making a child resistant package comprising:

laminating an outer film layer to an inner film layer to form a laminate;

forming an outer die cut in the outer film layer to define a peripheral edge of a peelable flap portion and at least one tab which is continuous with the peelable flap portion;

forming an inner die cut in the inner film layer to define a location of an opening, wherein the inner die cut is formed inwardly of the outer die cut;

forming the laminate into a package having a first panel and at least two second panels joined to the first panel, wherein the second panels are disposed in a plane which is different from the plane of the first panel

wherein the at least one tab is disposed on one of the at least two second panels;

wherein the opening is disposed in the first panel; and

wherein the peripheral edge of the peelable flap portion comprises a connecting portion and two leg portions and wherein a first leg portion is disposed substantially on one second panel of the package and a second leg portion is disposed substantially on a different second panel of the package.

1/15

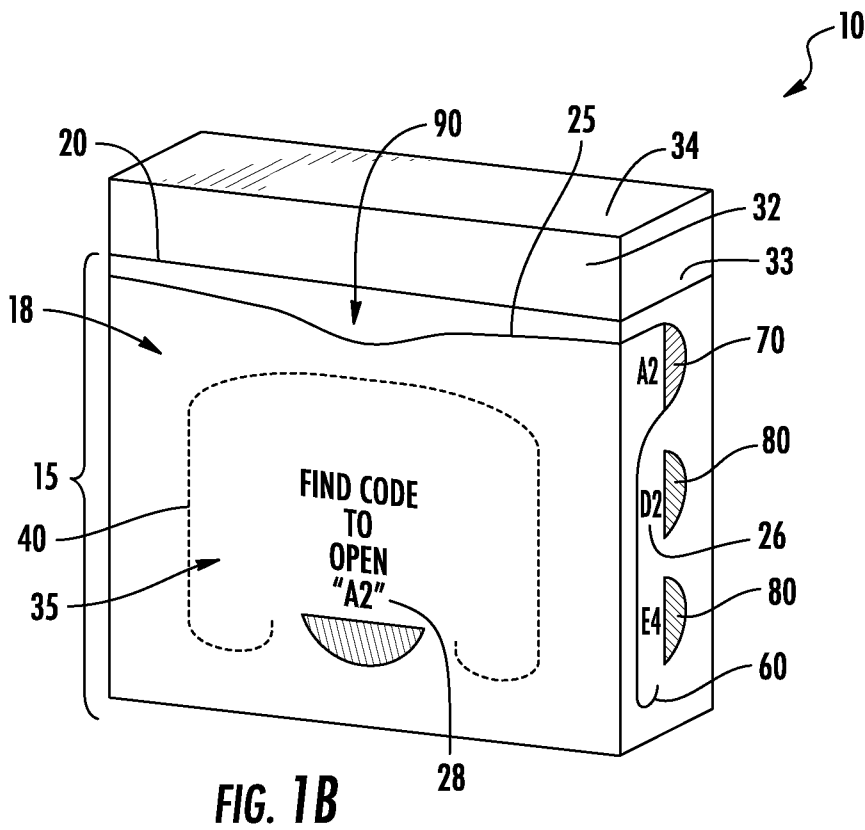
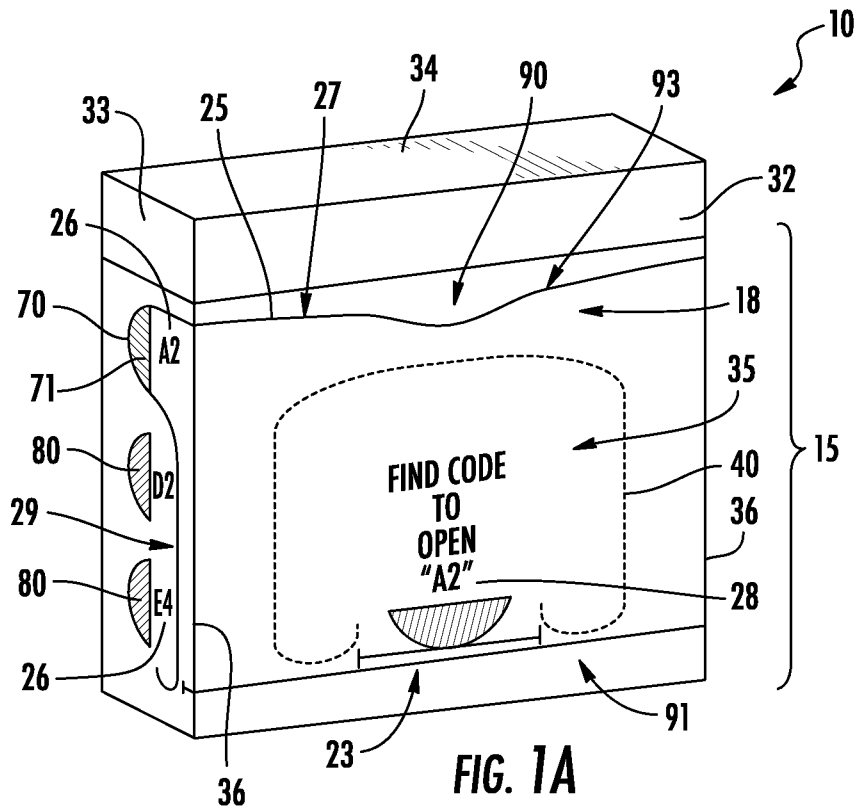

2/15

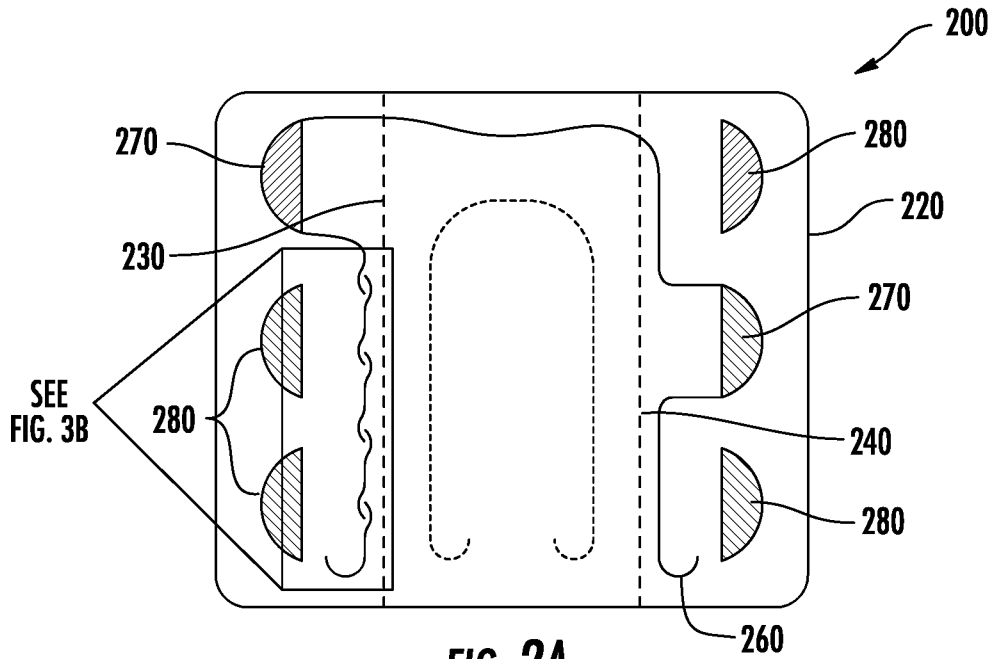

FIG. 2A

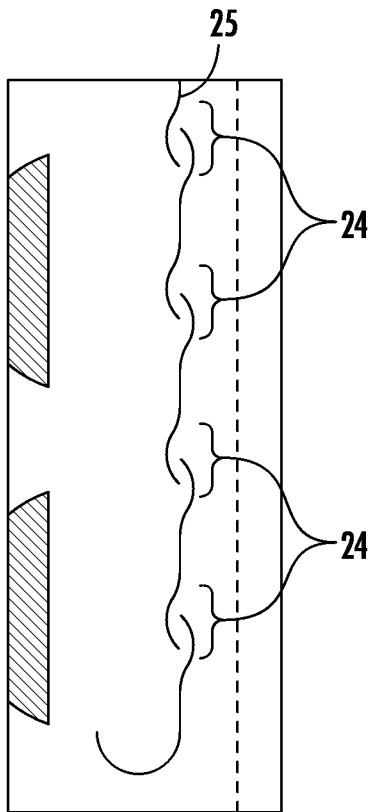

FIG. 2B

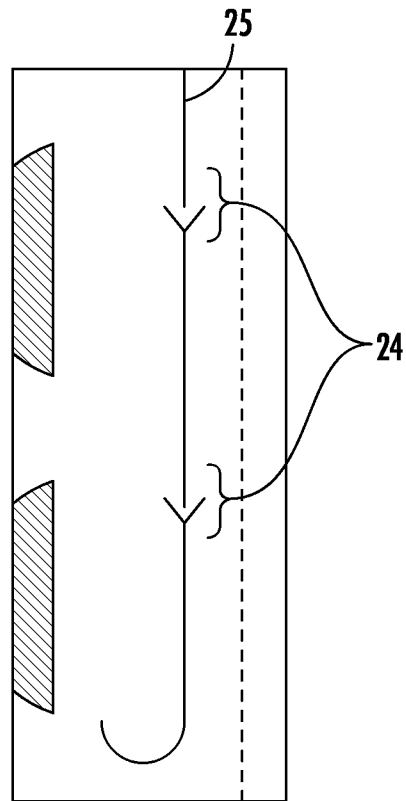

FIG. 2C

3/15

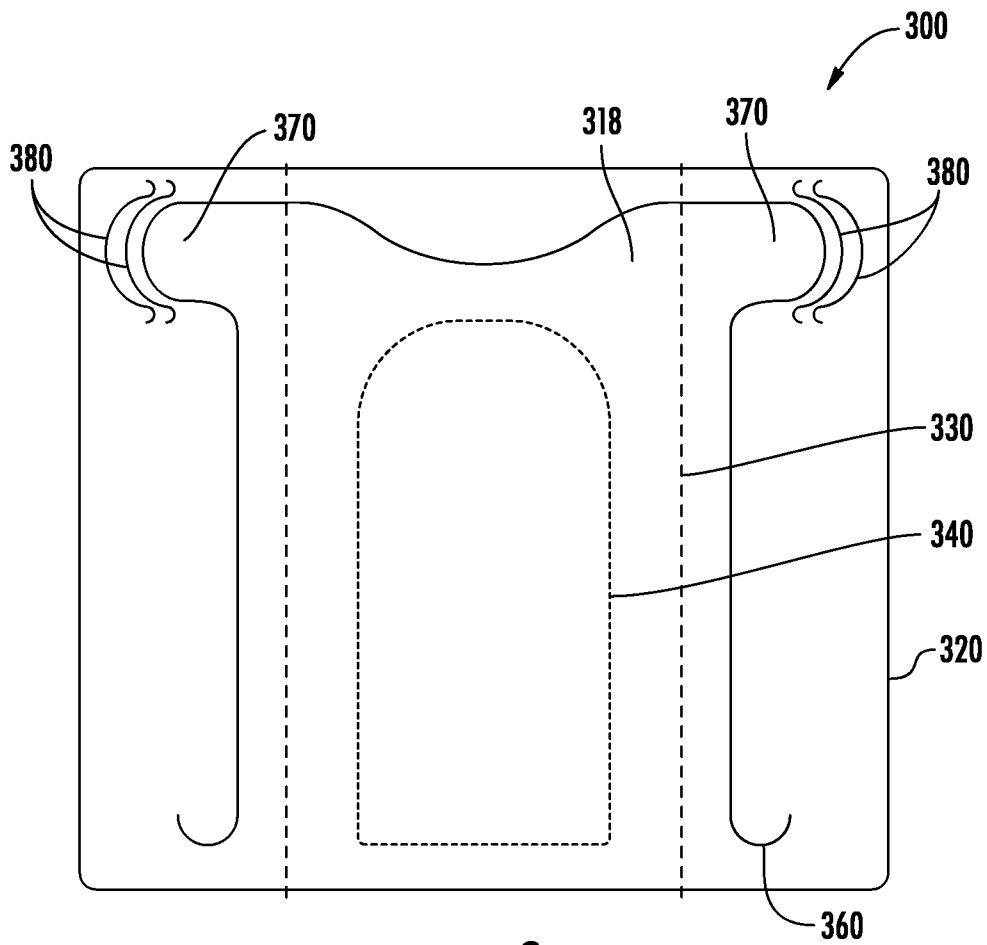

FIG. 3

4/15

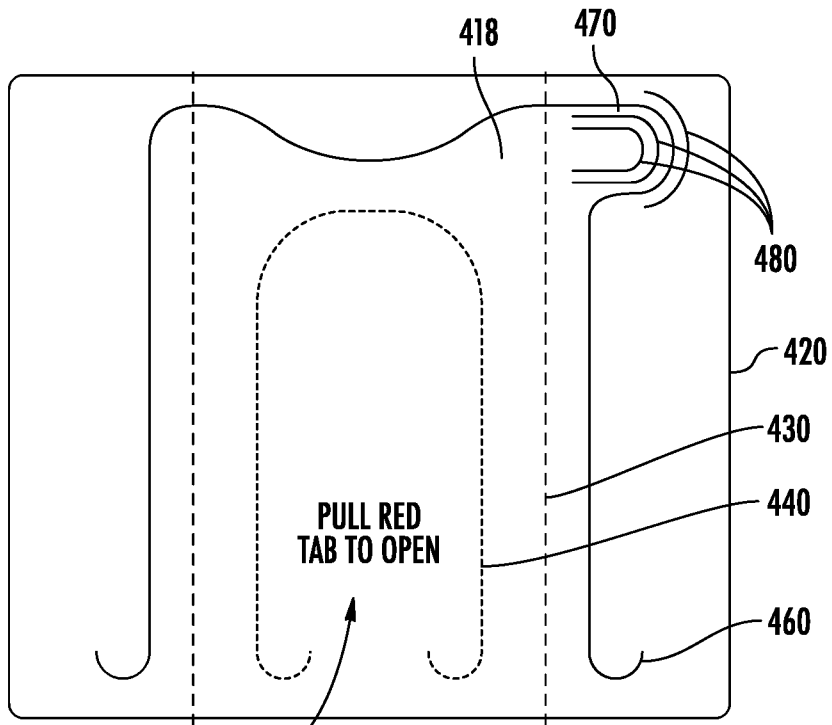

FIG. 4A

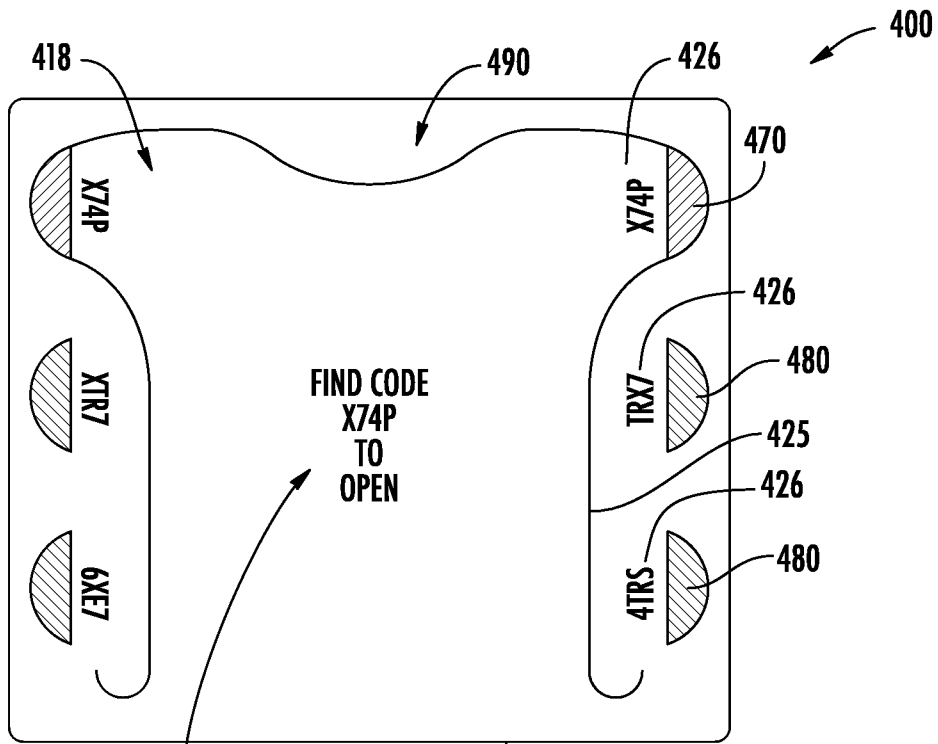

FIG. 4B

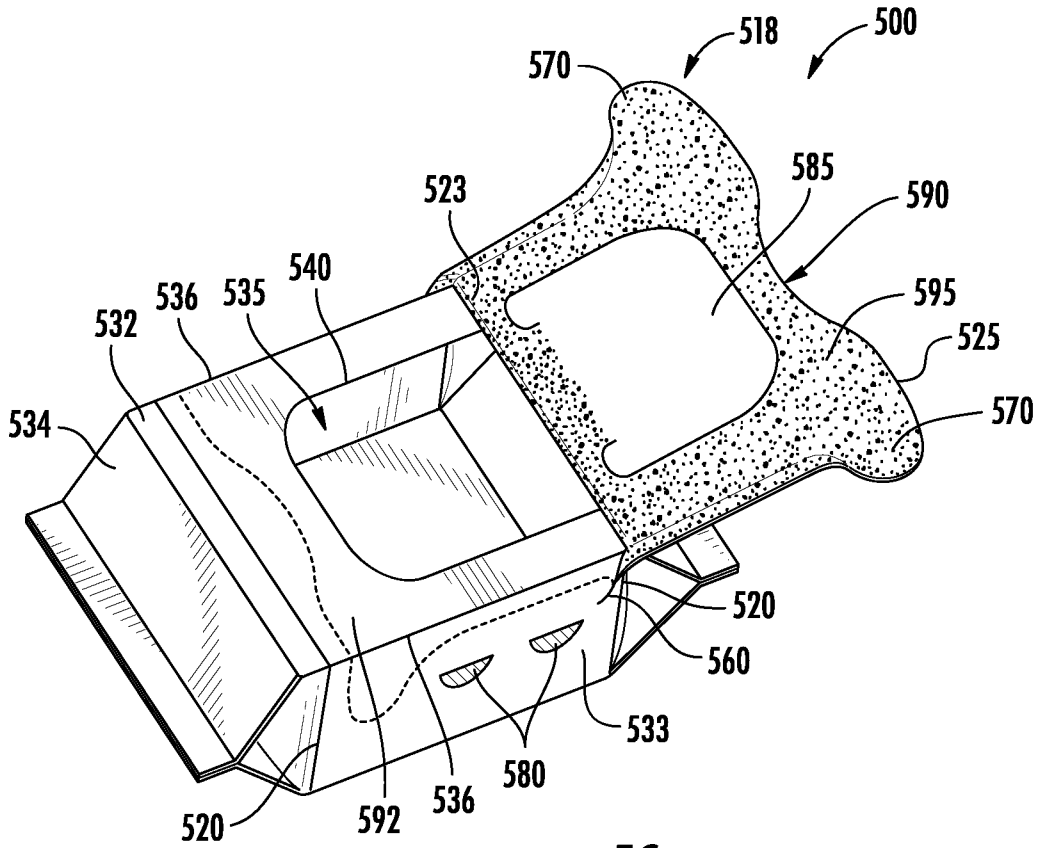

FIG. 5C

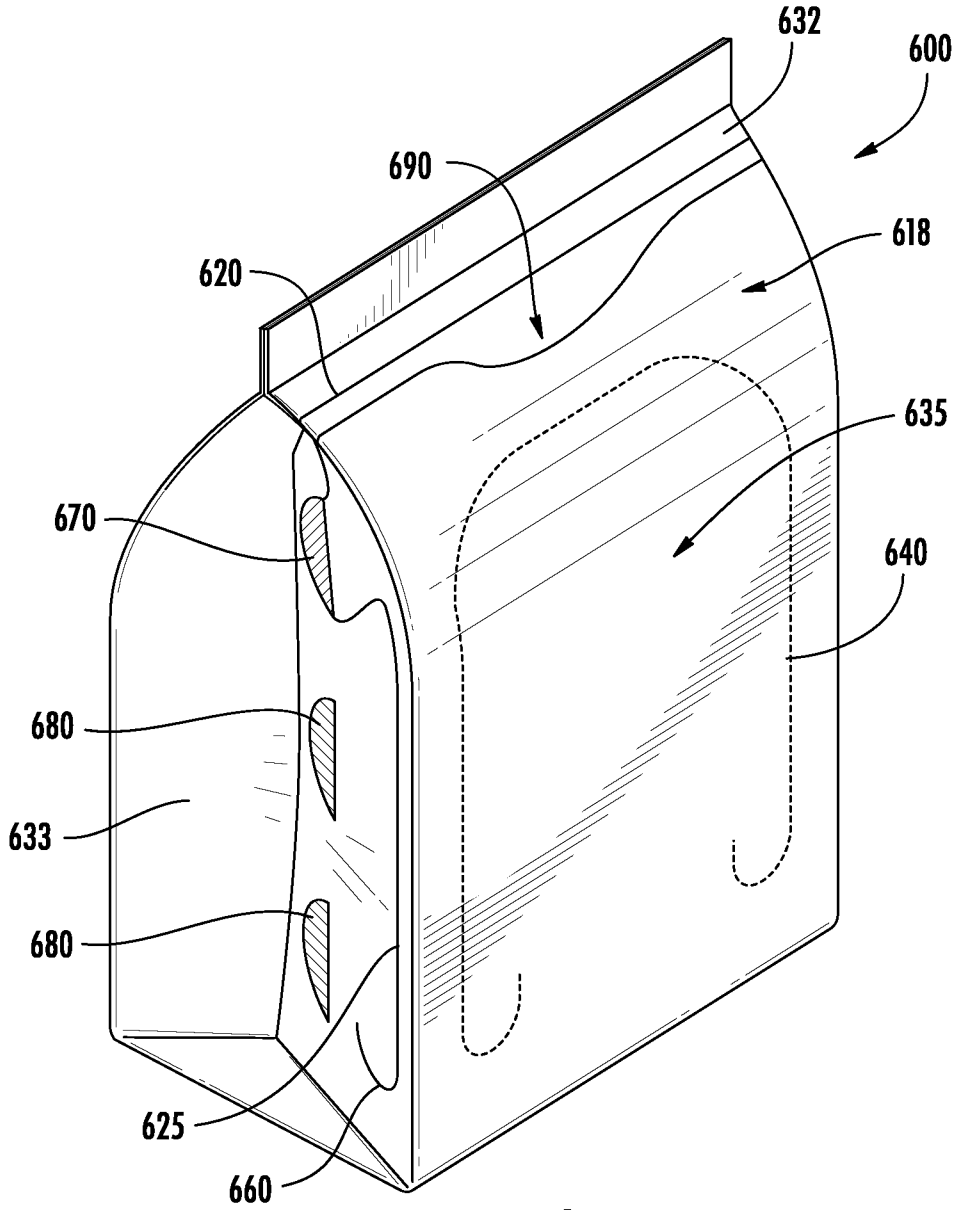

FIG. 6

8/15

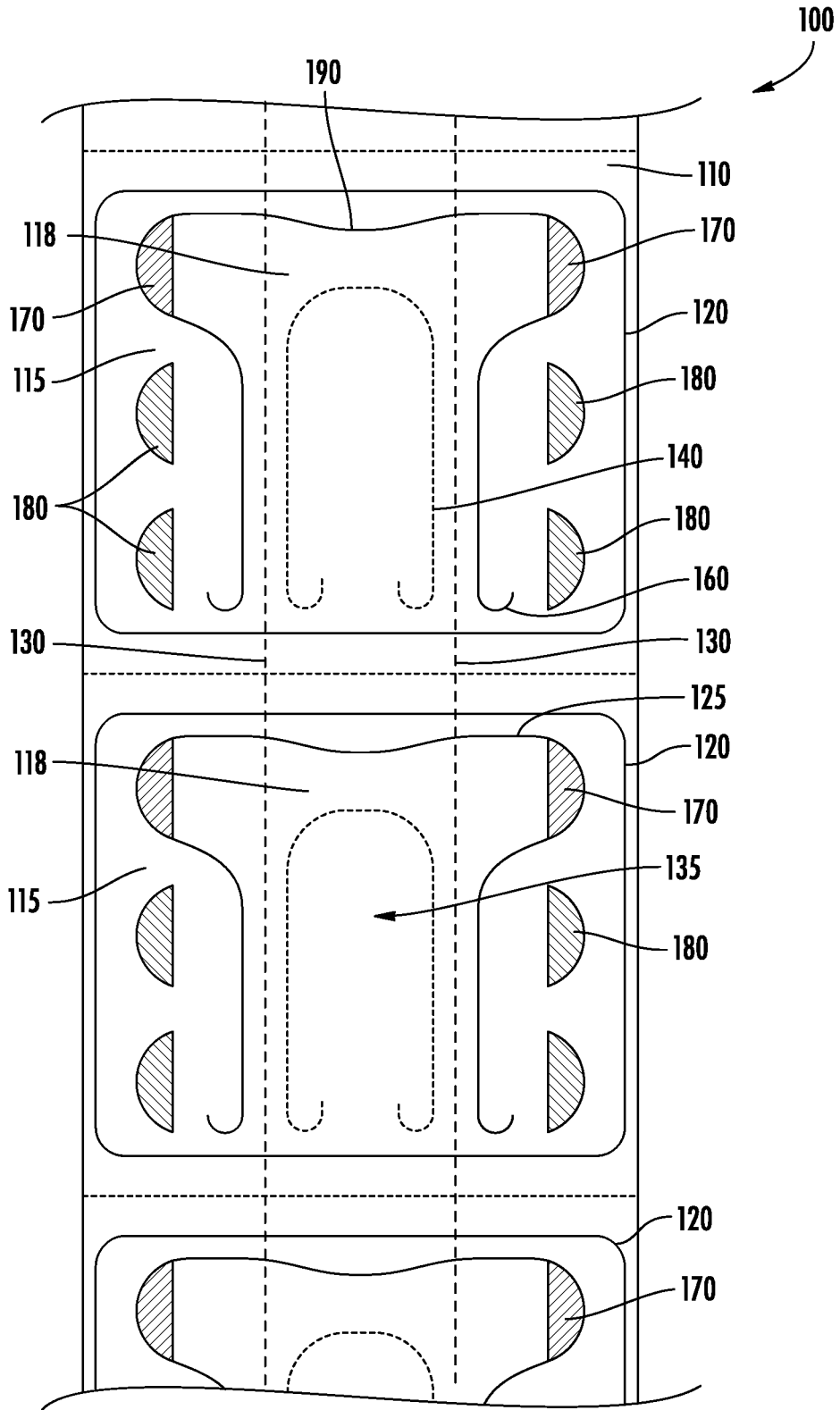

FIG. 7

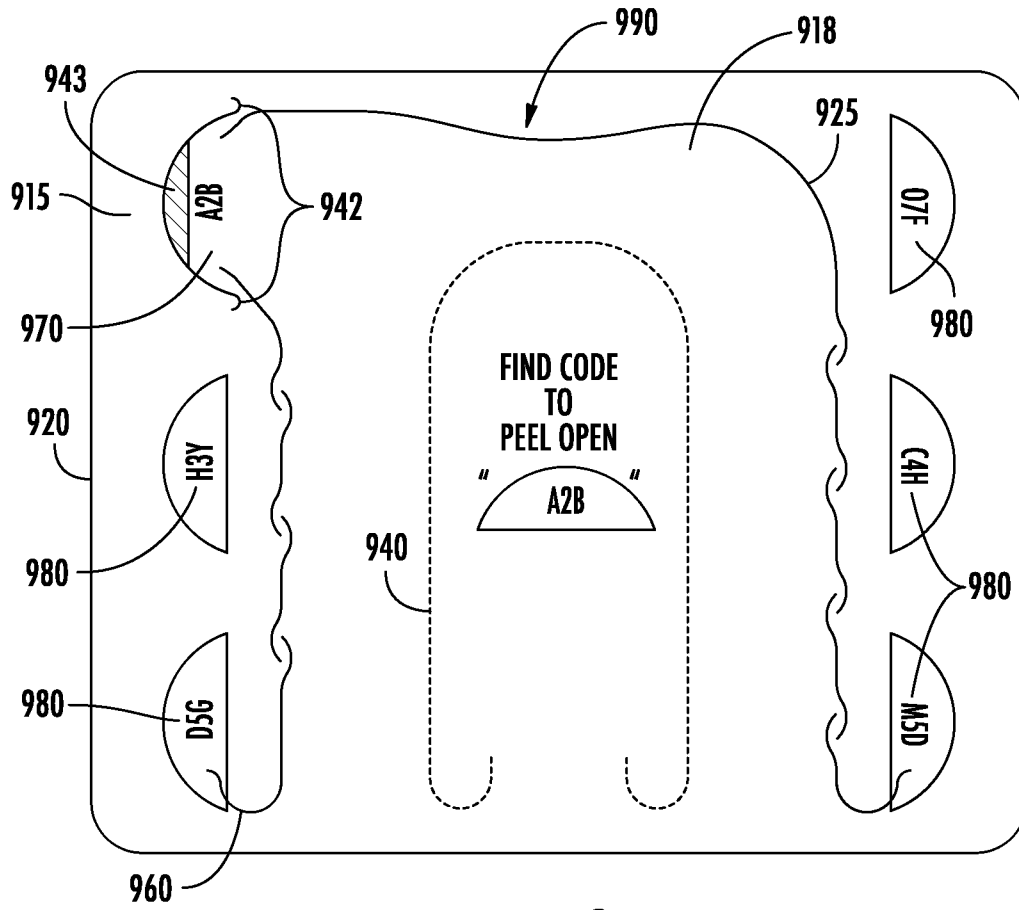

FIG. 9

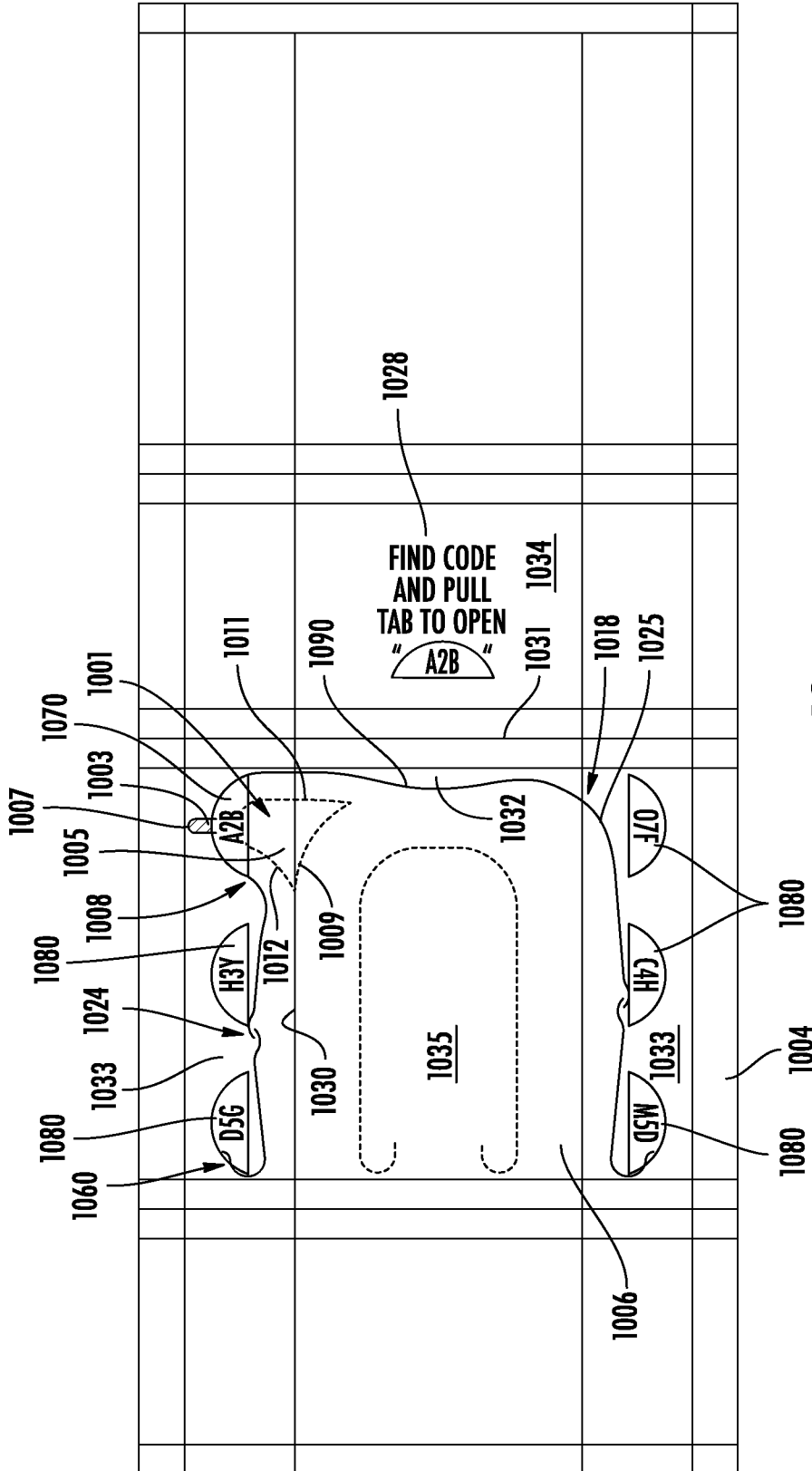

FIG. 10

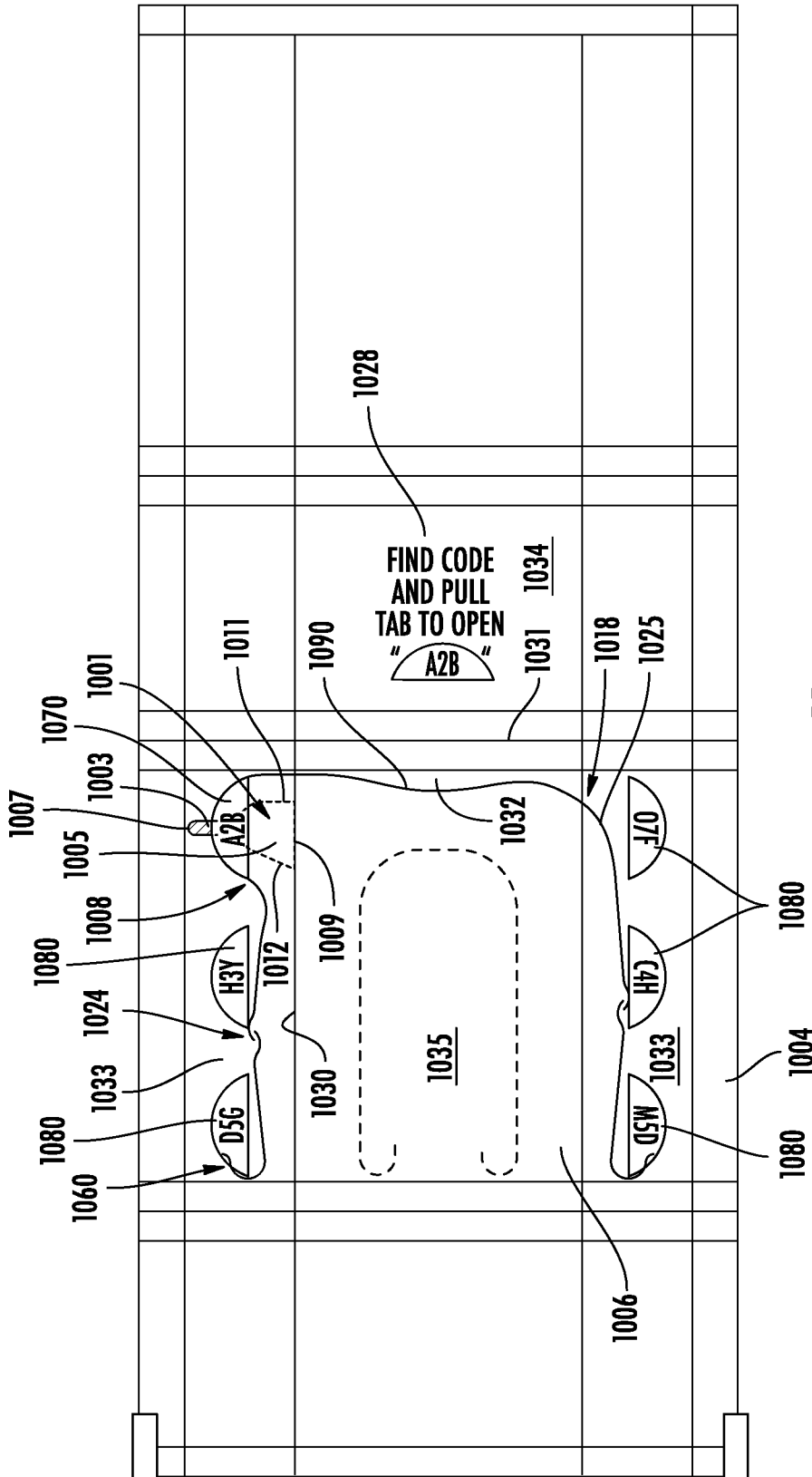

FIG. 11

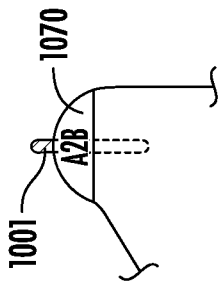

FIG. 12A

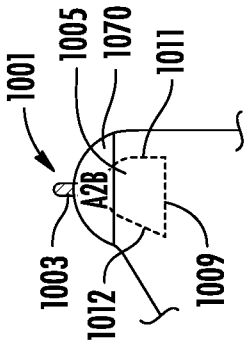

FIG. 12G

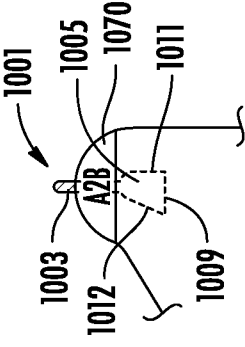

FIG. 12J

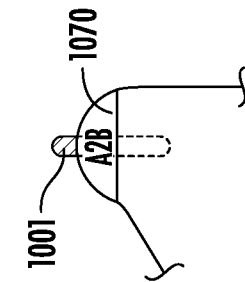

FIG. 12B

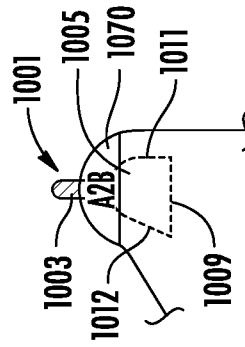

FIG. 12H

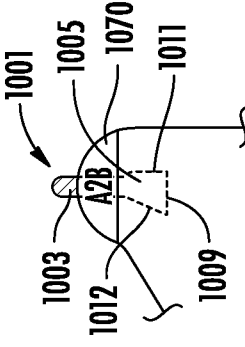

FIG. 12K

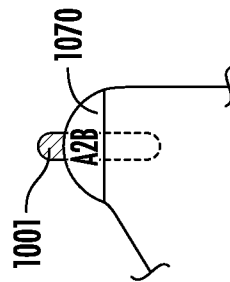

FIG. 12C

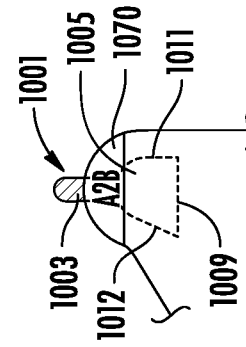

FIG. 12I

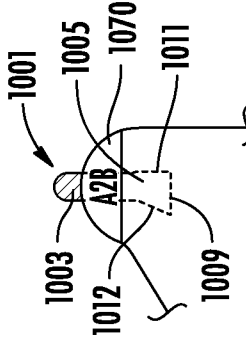

FIG. 12L

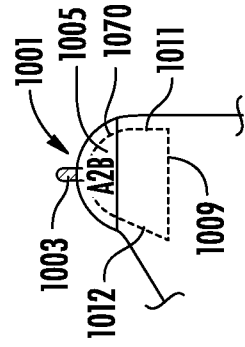

FIG. 12D

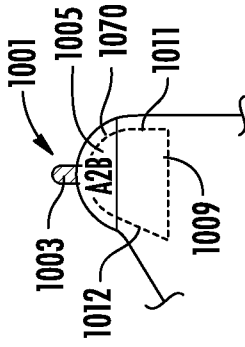

FIG. 12E

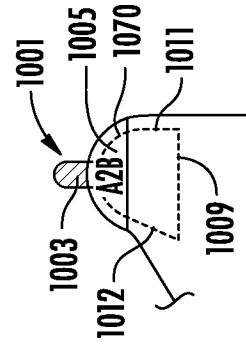

FIG. 12F

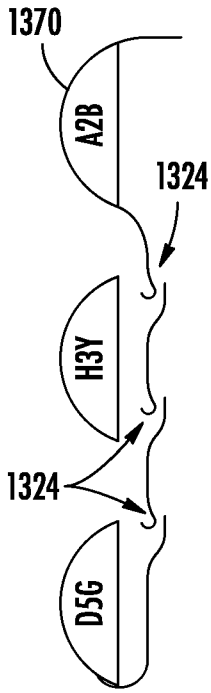

FIG. 13A

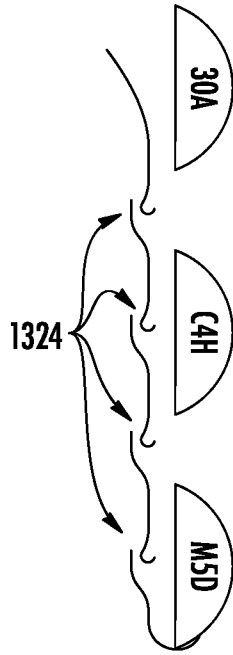

FIG. 13B

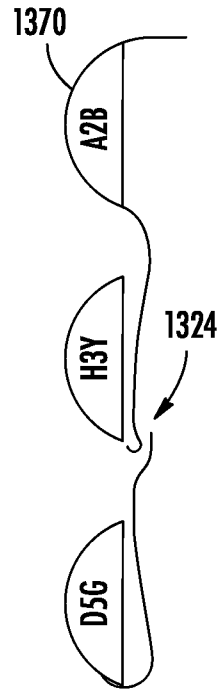

FIG. 13C

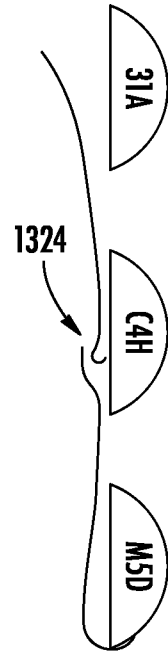

FIG. 13D

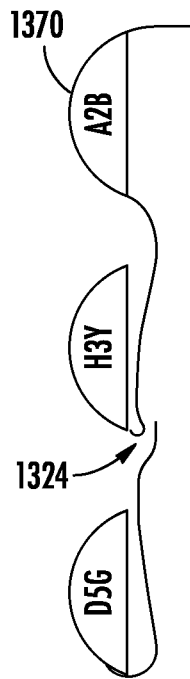

FIG. 13E

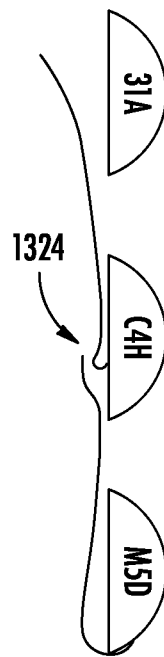

FIG. 13F

15/15

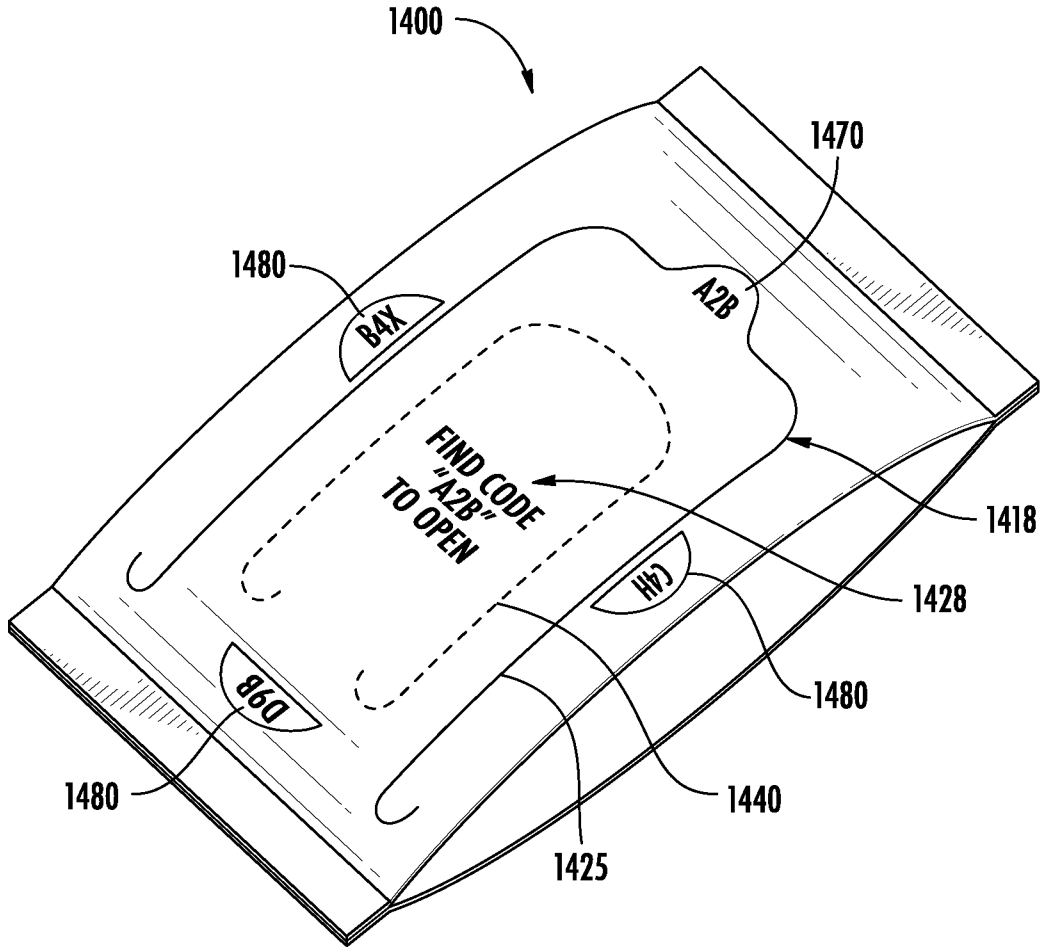

FIG. 14

