

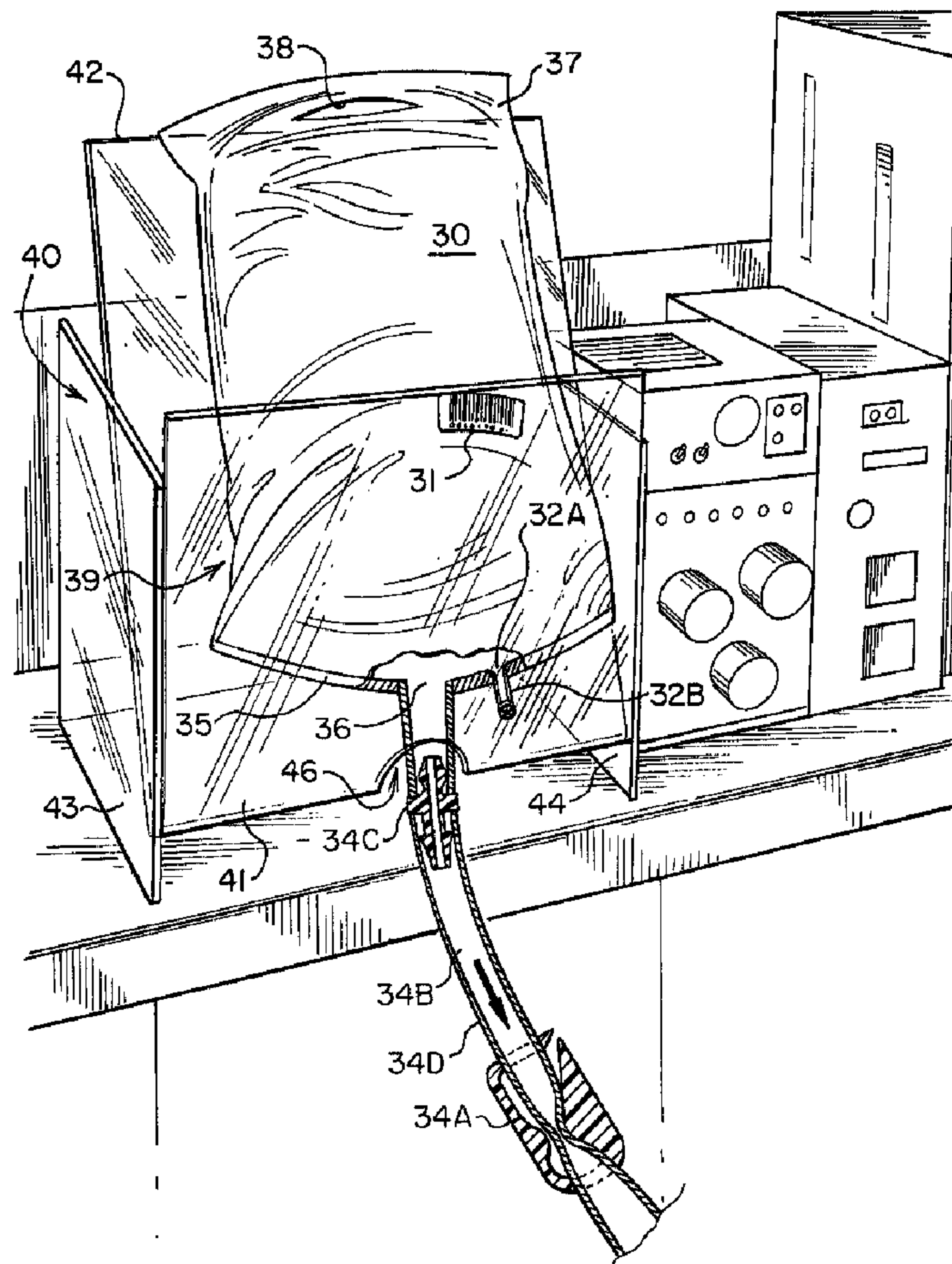

(86) Date de dépôt PCT/PCT Filing Date: 1999/07/30
 (87) Date publication PCT/PCT Publication Date: 2000/02/10
 (45) Date de délivrance/Issue Date: 2008/06/03
 (85) Entrée phase nationale/National Entry: 2001/01/04
 (86) N° demande PCT/PCT Application No.: US 1999/017280
 (87) N° publication PCT/PCT Publication No.: 2000/006976
 (30) Priorités/Priorities: 1998/07/31 (US60/094,896);
 1998/07/31 (US60/094,831); 1998/07/31 (US60/094,830)

(51) Cl.Int./Int.Cl. *B65D 30/24* (2006.01),
B65D 33/36 (2006.01), *B67D 3/00* (2006.01),
B67D 5/08 (2006.01), *B67D 5/22* (2006.01),
B67D 5/34 (2006.01), *B67D 5/64* (2006.01),
A61J 1/10 (2006.01), *G01F 11/28* (2006.01)
 (72) Inventeurs/Inventors:
 TEMPLAR, DENNIS L., US;
 NEAS, EDWIN D., US
 (73) Propriétaire/Owner:
 CHATA BIOSYSTEMS, INC., US
 (74) Agent: JOHNSON, ERNEST PETER

(54) Titre : APPAREIL CONTENANT/TRANSPORTANT UNE SUBSTANCE FLUIDE
 (54) Title: VESSEL FOR CONTAINING/TRANSPORTING A FLUENT SUBSTANCE



(57) Abrégé/Abstract:

An apparatus, having a flexible-walled vessel (20) compatible with a fluent substance not for direct consumption by mammals, for transporting the fluent substance and dispensing during research, testing, and other related processes. The process is separate

(57) Abrégé(suite)/Abstract(continued):

from a filling-site where the vessel is filled. The vessel, as oriented by a support framework (40), has an upper-end (27) and a lower-portion (29) with at least one port (36) through which the fluent substance is dispensed, and an outwardly-facing indicia (31). This port is in communication with a primary flow channel (24B) and a valve (24A) for controlling the dispensing of a preselected amount of the substance as needed during the process. A second flow channel (52B), in communication with a second port (52A) of the vessel's lower-end, may be added for filling the vessel at the filling-site. Also, an associated method of transporting a fluent substance for dispensing during a production/test process that uses a flexible-walled vessel is set forth.

PCTWORLD INTELLECTUAL PROPERTY ORGANIZATION
International Bureau

INTERNATIONAL APPLICATION PUBLISHED UNDER THE PATENT COOPERATION TREATY (PCT)

(51) International Patent Classification ⁶ : G01F 11/00	A1	(11) International Publication Number: WO 00/06976 (43) International Publication Date: 10 February 2000 (10.02.00)
(21) International Application Number: PCT/US99/17280 (22) International Filing Date: 30 July 1999 (30.07.99) (30) Priority Data: 60/094,830 31 July 1998 (31.07.98) US 60/094,831 31 July 1998 (31.07.98) US 60/094,896 31 July 1998 (31.07.98) US (71)(72) Applicants and Inventors: NEAS, Edwin, D. [US/US]; Suite A, 135 West Oak, Fort Collins, CO 80524 (US). TEMPLAR, Dennis, L. [US/US]; 7421 Vardon Way, Fort Collins, CO 80528 (US). (74) Agent: MACHELEDT, Jean, M.; Macheledt Bales & Johnson LLP, Suite B100, 501 Skysail Lane, Fort Collins, CO 80525-3133 (US).	(81) Designated States: AU, CA, CN, MX, NZ, US, European patent (AT, BE, CH, CY, DE, DK, ES, FI, FR, GB, GR, IE, IT, LU, MC, NL, PT, SE). Published <i>With international search report.</i> <i>With amended claims.</i>	

(54) Title: VESSEL FOR CONTAINING/TRANSPORTING A FLUENT SUBSTANCE**(57) Abstract**

An apparatus, having a flexible-walled vessel (20) compatible with a fluent substance not for direct consumption by mammals, for transporting the fluent substance and dispensing during research, testing, and other related processes. The process is separate from a filling-site where the vessel is filled. The vessel, as oriented by a support framework (40), has an upper-end (27) and a lower-portion (29) with at least one port (36) through which the fluent substance is dispensed, and an outwardly-facing indicia (31). This port is in communication with a primary flow channel (24B) and a valve (24A) for controlling the dispensing of a preselected amount of the substance as needed during the process. A second flow channel (52B), in communication with a second port (52A) of the vessel's lower-end, may be added for filling the vessel at the filling-site. Also, an associated method of transporting a fluent substance for dispensing during a production/test process that uses a flexible-walled vessel is set forth.

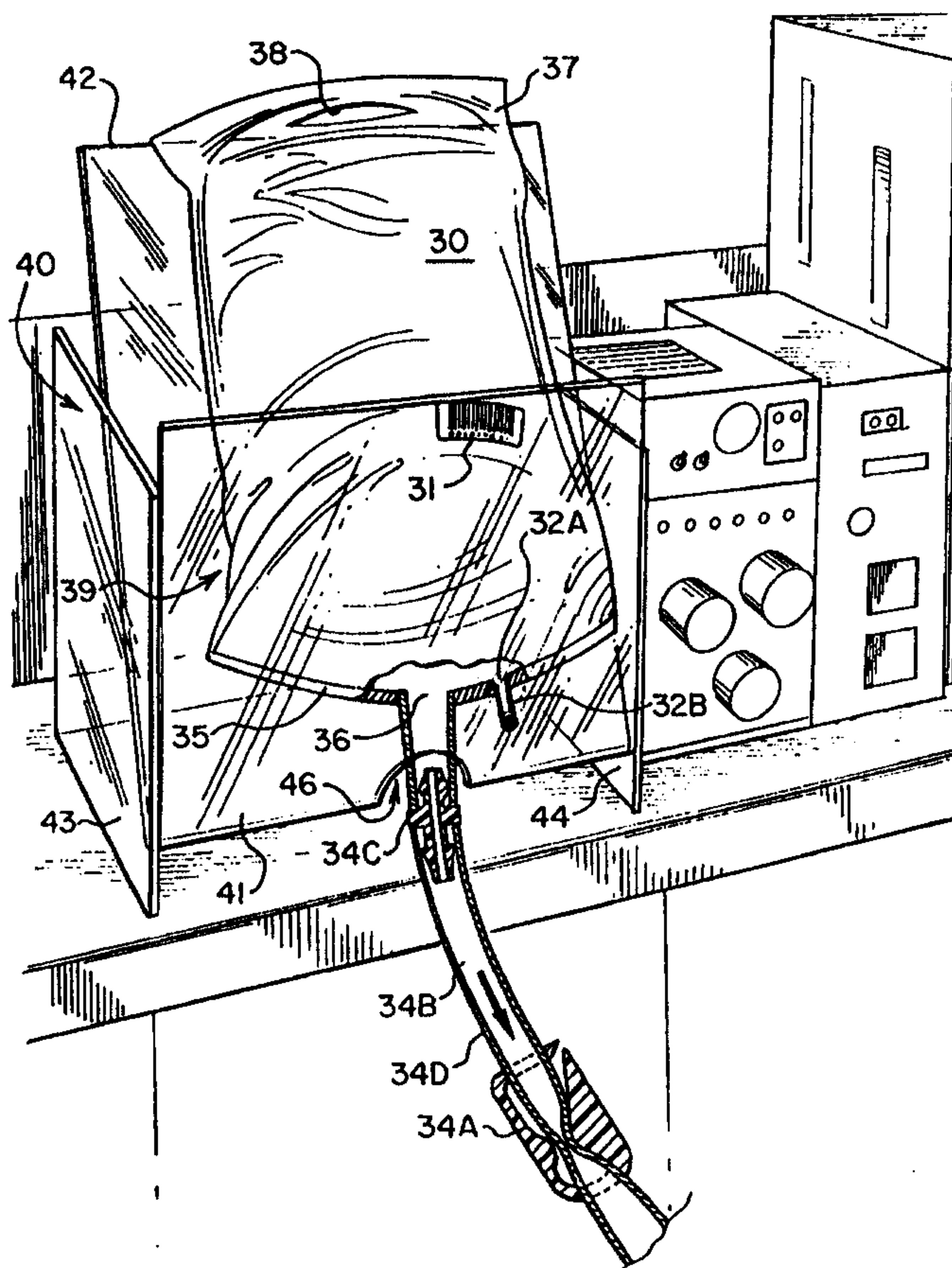

VESSEL FOR CONTAINING/TRANSPORTING A FLUENT SUBSTANCE

5

Background of the Invention

In general, the present invention relates to the packaging into a suitable container and transport over some distance, of fluids in liquid form destined for use in a "downstream", or subsequent, manufacturing/product-fabrication/test process. This disclosure is, by and large, *not* concerned with the transport and administering of medical solutions for mammalian use/consumption (including intravenous delivery of medicines and nutrients to humans and other mammals). But rather, the present invention relates to the novel containment for shipping and ultimate dispensing (preferably gravity fed) for ready use in a manufacturing/product-fabrication/test process (*whether* the process is deemed part of a commercial enterprise or done in a basic-research facility), of "fluent" substances from the same flexible vessel— without the need for mid-stream staging containers. The flexible walls of the vessel have an outwardly-facing identification indicia (for purposes of tracking/quality control and inventory) and are preferably made of a flexible material compatible with the fluent contents. A portable framework is used to support the vessel when dispensing its contents.

20

The filling of polymeric bags with liquids for storage and dispensing is not, by itself, new. Modern human and veterinary medicine conveniently uses intravenous fluid ("IV") bags for bedside administration of medicine, nutrients, and other solutions (water, saline solution, dialysis solutions, etc.) to patients in hospitals, nursing-care facilities, clinics, mobile critical-care transporters (life-flight helicopters, ambulances, and medically-equipped airplanes), and to patients who are well enough to have been sent home. Apart from the medical use of polymeric bags—at least one thin flexible bag having a "tent structure" and a multi-component specially-designed dispensing valve has been patented in the U.S. The bag is filled with *still wine*, shipped, and stored *intact* until a keeper ring is stripped away so that a sharp plunger is free to thrust inwardly to pierce the bag. Although the patent indicates this tent structure bag can stand up on a table for dispensing, it has not been seen in general use. But rather, wine bags seen in kitchen refrigerators are supported by rectangular cardboard boxes designed for dispensing in a horizontal orientation.

25

On a much different and greater scale than this, one finds the instant invention. It addresses a need specifically identified by the inventor hereof in the manufacturing/production/test arena (whether for commercial production and/or basic research) for less-costly

35

ways to ship and dispense solutions used in the commercial manufacture, research/ bench-testing, fabrication for laboratory/research use, and so on, of products. In the past, the design efforts of storage and transport containers have been driven, by-and-large, by the requirement that the walls of the containers be compatible with the solutions contained therein (such as reagents, organics, cleaning/sterilizing solutions, pesticides, etc.). Glass bottles, although very breakable and heavy to transport, have primarily been the container of choice due to the relative stability of glass and the compatibility of glass with so many solutions. And, while wall-compatibility is an important design consideration of storage vessels (due to the need to use containers made of materials that are substantially inert with respect to corrosion and do not leach extractables into the solutions they contain) — wall-compatibility can no longer be the only major design consideration of solution storage vessels. This is especially true as shipping and handling costs continue to sharply increase; such costs include the additional labor of skilled technicians that must be employed to properly measure/dispense and carefully use (without contaminating) the solutions, the cost of brittle-container breakage during shipment and/or use, as well as costs associated with the sheer weight of hard walled containers.

Due to the ingenious effort and targeted problem identification, the novel apparatus and method of containing for transport and dispensing a fluent substance as well as the novel method of building an order for replenishing stock, disclosed herein, are targeted to processes performed in connection with commercial as well as basic research purposes—including the fabrication and/or analysis/test of products and constituents thereof, whether the product is headed for commercial sale; bench-testing of products and their constituents; beaker cleaning; and so on.

As one can appreciate, *unlike* the instant invention, known hard-walled storage containers used for transporting solutions delivered to a manufacturing plant or research environment generally require a substantial amount of labor-intensive packing material to surround the containers in order to ship them any distance using common carriers. Although there have been a couple of reagent bags patented as designed for specialized test equipment, these designs do not accommodate large-scale production or bench-test/laboratory use of reagent solutions. Surprisingly, there simply is no adequate low-cost storage-for-transport alternative to the hard-walled containers (made, mostly, of glass and brittle plastics) currently being used for shipping the large quantities of solutions used day-in and day-out in manufacturing and research facilities.

The new apparatus for transporting a fluent substance and method were developed to address the problems associated with shipping heavy, breakable hard-walled containers which are cumbersome to use and store in a manufacturing/test environment. The new apparatus and method, as designed, offer a lower-cost and less labor-intensive alternative that utilizes space

more-efficiently while at the same time provides sufficient durability. As can be appreciated, in the spirit and scope of suggested design goals (whether expressly communicated herein) and as described further, the flexible-walled vessels can be fabricated from many suitable materials into many different shapes and sizes, filled with countless different types of reagents, cleaning solutions, solvents, pesticides and other fluent substances, then transported to, and used in, production/test environments (including food production) throughout the world.

Summary of the Invention

It is a primary object of this invention to provide an apparatus and associated method for transporting in a flexible-walled vessel a fluent substance for ready dispensing there-from during a production/product-fabrication/test process (*whether* deemed part of a commercial enterprise or done in a basic-research facility). The vessel, which has an upper end and a lower portion having at least one port through which the fluent substance is dispensed, can be oriented by a support framework for the dispensing. It is also an object of this invention that such an apparatus and method utilize a valve of some type for controlling the dispensing of a preselected amount of the fluent substance during the process. A further object is to provide a method of building an order for replenishing stock of a fluent substance contained in a flexible-walled vessel having an indicia.

The advantages of providing the new apparatus and associated new methods are as follows:

(a) The inventive vessel is preferably used for one-time dispensing of its contents (and, thereafter, disposed-of). A vessel may be reused by refilling with an identical fluent contents for another dispensing (reuse depends on the level of sterilization needed for its fluent contents, as well as the structural integrity of the flexible material). Regardless of reuse, vessels are preferably reclaimed by recycling the flexible material after its contents has been dispensed.

(b) Versatility -- The invention can be used for dispensing reagents, cleaning solutions, solvents, pesticides, etc., used in a *wide* range of production/testing environments to carry out associated processes (*whether* carried out as part of a commercial enterprise or done in a basic-research facility) such as : end-product fabrication and/or QC testing; in-line monitoring and/or mixing of constituents of a product; sample bench-testing of end-products or constituents thereof for purposes of quality control (QC); bench-testing of a product undergoing research to assess its manufacturability; plus, testing/sample monitoring, etc., in a 'pure' research sense of a material or substance (*e.g.*, material identification, measuring properties and behaviour, and so on).

(c) Simplicity of use -- The new vessel allows for reliable transporting to a dispensing site, ease of positioning/orienting for dispensing, plus straightforward repositioning within the process, as necessary, and later removal of the vessel from the process, all without disruption of the production/test environment.

(d) The design of the apparatus and method is such that it allows for handy integration into automated equipment currently in use in the lab or on-the-floor. The use of the apparatus in automated equipment decreases the opportunity for mistakes and safety hazards associated with making large quantities of chemical reagents and transporting from a mixing site to equipment.

5 (e) Structural design flexibility—The vessel may be fabricated of flexible stock material (whether tube-stock, sheet-stock, multi-layered, etc.) formed into one of many suitable ergonomic shapes of varying capacity depending upon: space available within the production/test process, the fluent substance contained and transported in the vessel, its use in the process, and the specific design of the framework fabricated to support the vessel during dispensing of its contents.

10 (f) Design for cost-effectiveness—The vessel, as designed, lowers the cost to ship (especially, since the vessel walls are preferably *not* hard/brittle and heavy), and the novel indicia on the vessel can include many coded pieces of information for cost-effective automatic tracking of vessel 'where-about's' as well as tracking use of its contents (especially important for inventory control, tracking lots, monitoring product shelf-life, and so on). The new method allows useful
15 information to be provided at a faster rate. By eliminating certain labor-intensive steps in a production/test process, such as the handling, measuring, and sterilization/aseptic-warming of reagents, cleaning solutions, pesticides, and/or other solutions (typically done by skilled technicians), production and lab costs may be greatly decreased.

(g) Design for decreasing the chance of operator error— The novel apparatus and method
20 are targeted to decrease the amount of handling required by technicians during vessel transport and the dispensing of its contents in a production/test process. Operator handling has traditionally included: removing the *correct* bottle from shelving holding many similarly-shaped hard walled bottles, pouring-out and measuring the requisite amount of the liquid reagent into a clean beaker, warming/sterilizing/mixing the beaker and its contents if necessary, dumping the contents of the
25 beaker into a test tube or vat to carry-out a predesignated step in the production/test process (*e.g.*, a chemical reaction, analysis, the dissolving of a solute, cleaning to remove rust/corrosion, etc.), cleaning the beaker for reuse. Decreasing such operator handling in a production/test process can substantially decrease the costs associated with carrying out the process, especially where highly trained technicians are needed to perform the operator handling (as is most often the case when
30 performing steps to manufacture/produce/test chemicals whether destined for commercial use or done in a research facility).

(h) Design for volume dispensing — The framework incorporated in the apparatus and method of the invention may, as needed, be designed to stage several of the novel vessels simultaneously (*for example*: several vessels can be hung from a sturdy projection of the
35 framework by passing the projection through an opening fabricated into each of the vessels; several vessels can be oriented between corresponding pairs of forward and aft walls lined up between two extending side strut-walls; or each of a plurality of vessels can be oriented by sliding

one of a plurality of vertical stem projections extending upwardly from a base of the framework, through a corresponding channel fabricated into the side of the vessel).

(i) Tracking method simplicity and efficiency – The method of building an order for replenishing stock of the invention is straight-forward to integrate and implement into existing
5 production and lab environments, especially using the novel indicia affixed to a vessel of the invention. This indicia also allows for automatic tracking of product/vessels along the production/test process. In light of strict internal quality control policies and federal regulations, as well as product liability concerns, reducing the number of manual steps required to order (including replenishing stock), track,
10 and ‘inventory’ fluent substances used in a production/test process makes the overall process more economically feasible and less-prone to operator error.

Briefly described, the invention includes an apparatus (having a flexible-walled Vessel compatible with a fluent substance) for transporting the fluent substance and dispensing during a production/test process. The process (whether it is carried out in a production/ manufacturing
15 environment or a research-laboratory environment) is separate from a filling site where the vessel is filled. The vessel, as oriented by a support framework for the dispensing, has an upper end and a lower portion. The lower portion has at least one port through which the fluent substance is dispensed during the process. This port is in communication with a primary flow channel and a valve for controlling the dispensing of a preselected amount of the substance as needed. The fluent substance can be selected
20 from the group consisting of liquid reagents, cleaning solutions, solvents, pesticides, and/or other fluent substances used in a production/test type environment (not for direct mammalian consumption). The vessel preferably has an outwardly-facing indicia, and the vessel’s upper end and a lower end of the vessel’s lower portion can be hermetically formed from sheet material such that: a volume is formed between these two ends having a capacity greater than that required to contain the preselected amount.
25 A second flow channel, in communication with a second port of the vessel’s lower end, may be added for filling the vessel at the filling site (and, once a vessel is filled, this second flow channel can be blocked re-opened for re-filling). The framework, if used, can have a multitude of suitable structural designs.

The invention also includes a method of transporting a fluent substance for dispensing during
30 a production/test process, including the steps of: providing a flexible-walled vessel with an upper end and a lower portion having at least one port in communication with a primary flow channel and a valve; filling the vessel, for the transporting, with the fluent substance at a filling-site that is separate from the production/test process; orienting the vessel (can be by way of a support framework); and dispensing through the valve, as needed, a preselected amount of the fluent substance. Preferably, the flexible-
35 walls are made of a material compatible with the fluent substance and the vessel has an outwardly-facing indicia (whether coded). Again, the fluent substance can be selected from the many reagents, pesticides, and cleaning and other solutions.

Also characterized herein, is a method (and associated system) of building an order for replenishing stock of a fluent substance (contained in a flexible-walled vessel) for use in a production/test process (whether it is carried out in a production environment or a research-laboratory environment). This method incorporates a novel broadened use of such a vessel with an indicia (a portion of which is machine-readable). The steps include: reading the indicia; transmitting at least a part of the information provided by the indicia to a remote processor; accessing a database with the remote processor to search for a package record that corresponds with the indicia information; using the indicia information, update and review an inventory file record (maintained by the remote processor); and generating the order for acceptance and, once accepted, automatically transmitting a request for determining a shipping-carrier and availability of stock at a warehouse. The step of reading the indicia can include using a computerized device to read the portion which is machine-readable, and/or visually reading the indicia and manually inputting a package serial number (PSN) therefrom to an input device at a dispensing location. A first-pass order may be generated and modified (via display), if necessary, prior to acceptance.

There are additional features that *further* distinguish this method of the invention: Adding the step of awaiting credit approval for the accepted order prior to performing the automatic transmission of a request (and the method may also require that, prior to giving this credit approval, a guarantee of payment of the order must be received by electronic transmission); and, the step of transmitting indicia information preferably includes connecting to a global information network through a modem interconnected to a computer-processing-unit (CPU) at a dispensing location where the production/test process takes place, and accessing a remote modem interconnected to said remote processor.

Brief Description of the Drawings

For purposes of illustrating the flexibility of design and versatility of the innovative preferred apparatus and method, the invention will be more particularly described by referencing the accompanying drawings of embodiments of the invention (in which like numerals designate like parts). The figures have been included to communicate the features of the invention by way of example, only, and are *in no way* intended to unduly limit the disclosure hereof.

FIGs. 1 and 2 are isomeric views of a typical hard-walled container packaging and transport system: A glass bottle with removable cap packed into a sturdy cardboard box with loose packing material (FIG. 1); and a large glass staging beaker into which the solution from the glass bottle is poured for mixing and storage prior to use in a laboratory.

FIG. 3 is an isometric view of a preferred packaging and transport system of the invention.

FIG. 4 is a side view of a plug-in spout and valve for use with the vessel;

FIG. 5 is a perspective view showing the vessel without and with a spout inserted;

FIGS. 6, 7, and 8 illustrate preferred embodiments of an apparatus of the
5 invention.

FIG. 9 illustrates a preferred vessel of the invention along with a bar-code reader.

FIGs. 10 and 11 are flow diagrams detailing preferred and alternate steps of a method of transporting a fluent substance for dispensing during a production/test process.

FIG. 12 is a flow diagram detailing preferred and alternate steps of a method of building an order for replenishing stock of a fluent substance utilizing, in an expanded novel manner, the indicia on a wall of a flexible-walled vessel of the invention.

FIG. 13 is a schematic representation of preferred hardware and the interconnections therebetween that may be used to carry out the method represented in FIG.12.

10 Detailed Description of the Preferred Embodiments

As identified above, the handling difficulties encountered by using typical hard-walled container packaging and transport systems currently in use are not hard to imagine: The glass bottles (10) having removable caps (11) often break during shipping; and for those bottles 10 packed well enough in heavy-sturdy cardboard boxes (12) with packing material (FIG. 1) to make it to a destination site in-tact, there are handling concerns along the production line related to storage, pulling of stock, and dispensing. For example, one must tightly grasp the bottle 10, pick it up, tip and pour its contents *without spillage* into a staging container such as the large glass staging beaker 14 shown in FIG. 2 atop a magnetic mixer (16) for use at some point in a manufacturing/ production/test process. In comparing FIGs. 1 and 2 with FIG. 3, one can readily appreciate the advantages of the flexible-walled vessel of the invention 20 in FIG. 3 which has been placed on top of a cardboard separator 22 into packing box 22.

The alternative vessel structure shown in FIGs. 4 and 5 has an upper end 27 and a lower portion 29 having at least one port 26 through which the fluent substance can be dispensed during a production/test process. Port 26 is in communication with a primary flow channel 24B and a valve 24A for controlling the dispensing of a preselected amount of the fluent substance contained in the vessel. The plug-in spout 24 has a sharpened end 24C for insertion at 26 to break the initial seal of a rubber septum (located at 26), a suitable valve 24A for controlling flow along channel 24B. A lower end, in the form of a wall (25) of suitably flexible material, has been hermetically integrated with vessel 20.

The preferred vessel 30 illustrated in FIG. 6 has an upper end 37 and a lower portion 39 having at least one port 36 through which the fluent substance is dispensed. Port 36 is in communication with a primary flow channel 34B and an interlocking pinch-clip valve 34A that is engaged to pinch the walls of tubing 34D connected to port 36 via suitable unitary connector 34C. At some point downstream from port 36 (for example, at the point connector 34C has been positioned), a flowmeter device can be readily added to measure flow out of vessel 30; this flow

measurement can readily be converted into a measurement of volume dispensed. Devices that take measurements of fluid flow through an orifice of known diameter are available on the market. Alternatively, the vessel may be made with a single piece of tubing an end of which is hermetically sealed directly to the lower end 35 (eliminating the use of connector 34C). Many suitable connectors and valves may be employed to control the flow along flexible tubing 34D, such as the unitary plastic valve shown at 34A (pinch-clamp distributed by Fresenius Medical Care AG). Here, upper end 37 and a lower end 35 of lower portion 39 have been hermetically formed from polymeric tubular stock material such that: preferably at least the front of the vessel 30 is transparent for viewing the level of its contents; and a pillow-shaped volume of vessel 30 has been formed between ends 35 and 37 having a capacity greater than that required to contain the preselected amount. Also, primary flow channel 34B has been hermetically sealed to prevent leakage and a support opening 38 is integrated within upper end 37. Although not shown specifically, here, primary flow channel 34B could readily be sealed to extend from along a sidewall of vessel 30. Port 36 can be used for filling, as well as the dispensing, of vessel 30; alternatively, a second port 32A in communication with a second flow channel 32B may be desired for filling, and once the vessel has been filled, this second flow channel can be permanently or temporarily blocked. An indicia 31 is affixed to vessel 30 by suitable means such as stick-backed label, silkscreened onto the flexible wall, connected by way of a pull-tag secured through opening 38, and so on. The indicia can, without being overly large in size, contain many different pieces of valuable information about the vessel 30, its contents, and the purchaser of the filled vessel 30, including a package serial number (PSN) tying the vessel to a lot-number of the batch from which it was manufactured/filled, shelf-life, the stock material used to form the vessel, and so on. The value of indicia 31 can be better appreciated in connection with FIGs. 12 and 13.

One of several preferred support framework structures is shown at 40 in FIG. 6. It is not critical to have such a framework, especially if the vessel is formed into a shape that is self-supportive and can remain oriented for dispensing. Framework 40 is formed of forward and aft walls (41 and 42 respectively) and side strut-walls (43, 44) which have been adhesively interconnected, plus a lower aperture 46 through which a primary flow channel can fit for dispensing the fluent substance. Here, for viewing the level of fluent substance in vessel 30, framework walls 41, 42, 43, 44 have been made of a transparent, plastic-resin material having sufficient structural integrity to orient vessel 30 upright.

FIG. 7 illustrates an alternative vessel 50 of the invention formed between ends 57 and 55 having indicia 51 and primary flow channel 54B. Flexible tubing 54D may have an integral connector-piece 54C as shown to connect the tubing to the dispensing port. A valve 54A for controlling the dispensing has a knurled set-screw 54E for pinching tubing 54D to stop flow of

the substance contained in vessel 50. Second flow channel 52B communicates with a second port 52A for filling along direction (arrow 54); and once filled, suitable plug such as that labeled 53 may be employed to temporarily or permanently block channel 52B. Vessel 50 is oriented by framework 60 having a weighted base 65 and stand 64. Upper-end 57 can be 'pinched' between forward and aft fingers (61 and 62), having first been opened by pivoting the fingers at hinge 63. FIG. 8 illustrates yet another novel apparatus of the invention wherein vessel 80 with indicia 81 and primary flow channel 84 is hung on a projection 91 of framework 90 having a stand 94 and a base 95 with rollers/wheels at 96 for moving the framework 90 from station-to-station within the production/test process, and dispensing, for example, into a container 89.

10

The flow-diagrams FIGs. 10, 11, and 12, as well as the hardware-communication schematic labeled FIG. 13, include additional written detail for convenient viewing to better appreciate the novel features of the invention. Turning, first, to box 210 in FIG. 10, preferably, the flexible-walled vessel is compatible with the fluent substance it contains: Not only is it preferable that the stock material be inert but that the amount of chemical 'extractables' that leach into the substance be negligible and undetectable by normal testing procedures used in laboratories. Examples of suitable commercially-available polymeric materials for building a vessel include flexible poly-vinyl chloride (PVC) film and CRYOVAC® M312 multi-layer film distributed by Cryovac Sealed Air Corporation. Sealed Air Corp. describes its CRYOVAC® M312 film product as an "alternative to glass bottles, poly-propylene and polyethylene materials" that is a "highly inert, very clear material that exhibits extremely low extractables in a wide variety of solutions." Next (box 212), fluent substances as used herein include the multitude of substances considered flowable, or capable of flowing such as reagents, cleaning solutions, water (with many uses, including use as an inorganic solvent), organics, pesticides, and other substances used in a production/test type environment. 'Reagent', as defined, is any chemical compound used in laboratory analyses to detect and identify specific constituents of the material being examined. Though reagents may be gases, liquids, or solids, they are usually prepared as solutions (in water or common solvents) of various concentrations, *e.g.*, 1 molar, 0.1 normal, etc. Several thousand chemicals of varying specificity are used as reagents; they are subject to strict specifications, especially as regards purity. A non-exhaustive list of reagents includes, without limitation: glacial acetic acid; sulfuric acid; hydrogen sulfide; dimethylglyoxime; potassium iodide; 0.05 M Potassium Phosphate, pH 7.5; Sodium Acetate Buffer Solution, pH 5.0; .5% SLS in 0.1 M Phosphate Buffer (pH 8.0); 0.05 M Potassium Phosphate, pH 6.8; .025 M Phosphate pH 3.2, has Phosphoric and Acetic Acid; .05 M Sodium Phosphate pH 6.8; 0.2% diethylamine in 0.2 M Potassium Phosphate. Generally, 'solvent' is a term that designates a liquid which can reduce certain solids or liquids to molecular or ionic form by relaxing the intermolecular forces that unite them. There are tens-of-thousands of solvents currently in use.

35

Prior to transport over any distance, the vessel is packaged 214 (see, also, FIG. 3 at 22). Then, either at the physical location/point of dispensing, or at a separate location, the vessel may be oriented by a support framework having a suitable structure corresponding with the specific structural design of the vessel. In the event a vessel is formed in such a manner that it can be oriented on its own, it is not critical that a support framework be used. As noted, the framework can have a number of suitable structures to support the vessel by: hanging (including, clipping as shown in FIG. 7) from the upper-end of the vessel, sliding a vertical rod of a counter-top framework through a side channel of the vessel, wedging the vessel between front and aft support walls (see, FIG. 6), and so on. Once positioned in place at the physical location of dispensing, a preselected amount, as needed, of the fluent substance is dispensed (218). As detailed in FIG. 11, and discussed above, step 210 can further include: 210A, hermetically forming the ends (e.g., FIG. 7 at 55, 57) of sheet-stock to form a desired storage capacity (preferably from about 5 milliliters to 20 Liters in volumetric-capacity); 210B, adding indicia (whether coded) for use in product tracking and inventory control; and 210C, including a second flow channel (for example, see FIG. 7 at 52B).

By way of example only, and not intended to specifically limit the disclosure hereof, a flexible vessel can be constructed of fluid and microbial impervious flexible sheet material that has minimal gas permeability to aid in maintaining the integrity of the chemistries packaged in the vessel (which, depending upon use, may be sparged or otherwise treated before being packaged in a flexible vessel). Preferably, to reduce shipping costs, the total weight of the flexible vessel is *less than* the weight of a hard-walled (e.g., glass or high-density polyethylene plastic) container large enough to hold an equivalent volume of liquid. The flexible material can be of a multi-layer construction, and in the event the contents of the vessel, once filled, requires some type of treatment (e.g., sterilization, electron beam irradiation, gamma irradiation, and so on), preferably a flexible material is used that can withstand such treatment with minimal, or no, degradation. One use for the packaged chemistries of a vessel of the invention, is during the process of High Performance Liquid Chromatography (HPLC). Such chemistries include high-purity water (H₂O), numerous buffered reagents, and organic solvents.

FIGs. 12 and 13 represent the flow of a preferred method of building an order for replenishing stock of a fluent substance utilizing, in an expanded manner, indicia (such as that shown at 31, 51, 81) on a wall of a flexible-walled vessel. Commercially available 'supply chain' software tools fall short of effective comprehensive use of the INTERNET® global information network and wireless (cellular) technologies to handle ordering and fulfillment of orders for reagents and other solutions used in a production/test environment. Each of the commercially available products only addresses one segment of the supply chain: There are "enterprise-wide"

systems (such as those distributed by the German company SAP, the European-based Baan, Oracle Corporation, and PeopleSoft, Inc.) and there are warehouse management software suppliers (Catalyst, EXE, and Manhattan) who have developed warehousing solutions.

5 Turning, to FIG. 12, a vessel with indicia is preferably used (box 310) in connection with the method of building an order. A portion of the indicia is encoded for reading/sensing with a reader-device interconnected to a computer, such as the handheld device illustrated in FIG. 9 at 100 to read/scan indicia 31 of vessel 30. Preferable modes of affixation of indicia (31) to a vessel (e.g., that shown at 30), have been discussed in connection with FIG. 6. As shown in more detail
10 in the schematic labeled FIG. 13, a remote processor must be (at 400) capable of accessing database information 402, represented here as separable 'local' databases of credit information and package records, which may incorporate special product-handling information from the manufacturer, and if not, a separate database of manufacturer records can be used. Also, if local database records 402 do not include warehouse stock and common carrier information, the remote
15 processor 400 should preferably be able to access such information via WAN 420 (e.g., INTERNET® global information network via modem, both through hardwired phone lines and cellular communication networks) to additional 'sub-databases' (e.g., warehouse stock availability 432 and common carrier location, cost, and availability 442).

20 The indicia is read 314 (visually or automatically by suitable electronic device, e.g., FIG. 9 at 100 and FIG. 13 at 414) and at least certain of the indicia information is transmitted to a remote processor (400 in FIG. 13). If the accessible database information (including 402, 432, 442) does not have a package record that corresponds with the transmitted indicia information 316, then the indicia information can be re-entered (318) and if no package record is matched the
25 second time (319), the indicia information may just not be in the database, yet: Write it to an 'exception' file for future use. If a match is made the indicia information is used (box 322) to begin building a replenishment order and corresponding shipment request. For example, a simple alphanumeric-text type search may be performed of the accessible database information 402, 432, 442 to find a package record that contains a package serial number (PSN) match to the PSN of
30 the indicia *as transmitted* (see box 314). Also, the indicia information is preferably used to update and review an inventory file record maintained by the remote processor for the dispensing site prior to generating the order for acceptance.

35 It may be desired, but certainly not critical, to include suitable means of communicating an initial 'first-pass' order to an order-authorization site (such as an interactive display monitor, FAX 405 or other hardcopy printing device 403, connected to remote processor 400). Also, the first-pass order may be communicated to someone at the dispensing site 410 for update and/or

modification (such as by display monitor at the dispensing location 410, or FAX 412 or other
hardcopy printing device 413, connected to remote processor 410). If a first-pass (or any updated
or later-modified version, for that matter) of the order is rejected for any reason (327), this
information must be communicated to the dispensing site 410, preferably via WAN 420. Action
5 necessary (arrow 328) can be taken to move the order to the next step, 329: Send the
replenishment order and shipping request to a credit module for automatic approval or rejection.
If credit approval is given 330, the final version of the order and shipping request is sent to a
transport planning system to choose carrier (based upon availability, location, cost, etc. at 440)
and check on product availability (430) for fulfillment of the order. If credit approval for the
10 order is not given (330), an individual may have to seek payment and/or payment guarantee
elsewhere and communicate this (box 332) to the remote processor for order fulfillment (334).

An approved order and shipping request (box 330) can be assigned an order-tracking
number, and if desired to keep track of multiple shipments, a shipment number can be assigned
15 to each such shipment. Once an order and shipping request has been sent to a transport planning
system 334, the transport planning system can access an off-site processor (440) and/or sub-
databases to collect information to find an available common-carrier and plus make a decision
about which carrier is most cost-effective, and so on. A warehouse management system (WMS),
whether run as a module on the remote processor 400 or performed off-site on a warehouse
20 computer processor 430, can be employed to locate available stock of vessels of fluent substance
in accordance with the approved order and shipping request (box 330). The WMS can include
the capability to manage the stock picking and packaging processes by way of communicating
with warehouse employees via portable-wireless device. The remote processor 400 can be
notified (via the WAN 420, for example) that a particular shipment of a particular order has been
25 picked from the warehouse and is on a carrier vehicle heading to the dispensing site. The remote
processor can automatically generate an invoice for that shipment and update an internal-local
accounts receivable database, as well as electronically send the invoice or print a copy for postal
mailing. Once the shipment safely reaches its destination, information concerning the vessels of
that shipment can be transmitted to the remote processor for updating the database 402 in a
30 manner similar to that set for at steps 312 and 314 in FIG. 12. It should be noted, that very
powerful computer systems (whether personal computers, workstations, or mainframe computers)
are commercially available for readily handling the computing tasks described above in connection
with FIGs. 12 and 13 in a cost-effective manner.

While certain representative embodiments and details have been shown merely for the
purpose of illustrating the invention, those skilled in the art will readily appreciate that various
modifications may be made to the invention without departing from the novel teachings or scope

of this invention. Accordingly, all such modifications are intended to be included within the scope of this invention as defined in the following claims. Although the commonly employed preamble phrase "comprising the steps of" may be used herein, or hereafter, in a method claim, the Applicants *in no way* intends to invoke Section 112 ¶6. Furthermore, in any claim that is filed hereafter, any means-plus-function clauses used, or later found to be present, are intended to cover the structures described herein as performing the recited function and not only structural equivalents but *also* equivalent structures.

What is claimed:

1. An apparatus for transporting a fluent substance for dispensing during a production process that is separate from a filling site, comprising:
5 a flexible-walled vessel compatible with the fluent substance;
the vessel comprising, when oriented by a support framework for the dispensing, an upper end and a lower portion having at least one port through which the fluent substance is dispensed during the production process;
the upper end and a lower end of the lower portion having been hermetically
10 formed;
the port in communication with a primary flow channel and a valve for controlling, independent of the support framework, the dispensing of a pre-selected amount of the fluent substance contained in the vessel as needed during the production process.
15
2. The apparatus of claim 1 comprising an outwardly-facing indicia on the vessel for use in connection with the production process.
3. The apparatus of claim 1 or 2 wherein the upper end and the lower end
20 having been hermetically formed from tubular stock that is polymeric and generally inert to the fluent substance, the stock being selected from the group consisting of flexible poly-vinyl chloride (PVC) film, and flexible multi-layer film.
4. The apparatus of claim 2 or 3 wherein the outwardly-facing indicia has
25 bar coding for tracking use of the vessel during the production process.

5. The apparatus of any one of claims 1 to 4 in which the vessel contains a fluent substance selected from the group consisting of liquid reagents, cleaning solutions, solvents, and pesticides.
- 5 6. The apparatus of any one of claims 1 to 5 in which the primary flow channel passes through and is hermetically sealed to the lower end.
7. The apparatus of claim 6 wherein the primary flow channel is a tube connected with the valve.
- 10
8. The apparatus of claim 5, 6 or 7 wherein the vessel forms a pillow-shaped volume having a capacity greater than that required to contain the fluent substance.
- 15 9. The apparatus of any one of claims 1 to 8 comprising:
 the support framework having a stand with a base and a projection that fits through a support opening integrated within the vessel upper end to hold the vessel for the dispensing.
- 20 10. The apparatus of any one of claims 1 to 6 comprising:
 a plug-in assembly for insertion into the port, the plug-in assembly comprising the primary flow channel and the valve.

11. The apparatus of claim 9 wherein the support framework comprises relatively rigid forward and aft walls, arranged at an acute angle and between which the vessel is positioned for the dispensing, and a lower aperture through which the primary flow channel fits.

5

12. The apparatus of any one of claims 1 to 11 wherein the lower end has a hermetically integrated second flow channel for filling the vessel, the second flow channel being blocked once the fluent substance has been introduced.

10

13. An apparatus for transporting a fluent substance for dispensing during a process, selected from the group consisting of production, and test processes, at a location that is separate from a filling site, comprising:

a flexible walled vessel compatible with the fluent substance;

15 the vessel comprising, when oriented by a support framework for the dispensing, an upper end and a lower portion having at least one port through which the fluent substance is dispensed during the test process;

the port being in communication with a primary flow channel and a valve for controlling the dispensing of a pre-selected amount of the fluent substance contained in the vessel, as needed; and

20

an outwardly-facing indicia on the vessel for use in connection with the process.

14. The apparatus of claim 13 in which the vessel contains the fluent substance selected from the group consisting of liquid reagents, cleaning solutions, solvents, and pesticides.

5 15. The apparatus of claim 13 or 14 wherein:

the upper end and a lower end of the lower portion have been hermetically formed from polymeric tubular stock material such that a pillow-shaped volume of the vessel is formed between the ends having a capacity greater than that required to contain the pre-selected amount;

10 the primary flow channel passes through and is hermetically sealed to the lower end;

a flowmeter device is operatively connected with the flow channel downstream of the port; and'

15 the indicia comprises alphanumeric coding for inventory control of the fluent substance.

16. The apparatus of claim 15 wherein the vessel forms a second port and the apparatus further comprises a second flow channel, in communication with the second port, for filling the vessel at the filling site; and

20 means for blocking the second flow channel.

17. The apparatus of claim 13, 14, 15 or 16 wherein the upper end and the lower end of the lower portion have been hermetically formed from the polymeric tubular material generally inert to the fluent substance and selected from the group consisting of poly-vinyl chloride (PVC) film, and flexible multi-layer film such
5 that a support opening is hermetically integrated along the top, bottom or side of the vessel; and

the support framework orients the vessel for the dispensing, the support framework comprising a stand having a projection that fits into the support opening and a base supporting the projection.

10

18. The apparatus of claim 17 wherein the support framework comprises relatively rigid forward and aft walls between which the vessel is positioned for the dispensing; and a lower aperture through which the primary flow channel fits for the dispensing; and

15 the apparatus further comprises a tubular extension in communication with the primary flow channel, the valve being operatively arranged along the tubular extension.

19. A method of transporting a fluent substance for dispensing during a production process, comprising the steps of:

providing a flexible-walled vessel with an upper end and a lower portion having at least one port in communication with a primary flow channel and a valve
5 for dispensing the fluent substance, the flexible walls made of a material compatible with the fluent substance;

filling the vessel, for the transporting, with the fluent substance at a filling site that is separate from the production process;

orienting the vessel by a support framework; and

10 dispensing through the valve independent of the support framework, as needed, a pre-selected amount of the fluent substance contained in the vessel.

20. The method of claim 19 wherein the step of filling uses a fluent substance selected from the group consisting of liquid reagents, cleaning solutions,
15 solvents, and pesticides; and the step of providing further comprises including an outwardly-facing indicia on the vessel for use in connection with the production process.

21. The method of claim 20 wherein the step of providing further comprises hermetically forming the upper end and a lower end of the lower portion into polymeric sheet material such that a volume of the vessel is formed between the ends having a capacity greater than that required to contain the pre-selected amount;
5 and

the step of orienting further comprises inserting at least a portion of a projection of the support framework through a support opening integrated within the upper end.

10 22. The method of claim 19 wherein:

the step of providing further comprises hermetically forming the upper end and a lower end of the lower portion into flexible sheet material;

the step of filling further comprises filling the vessel through the at least one port; and

15 the step of orienting further comprises positioning the vessel between relatively rigid forward and aft walls of the support framework such that the primary flow channel fits through a lower aperture of the framework for the dispensing.

23. The method of claim 19 wherein:

the step of providing further comprises including an outwardly-facing indicia on the vessel and a second flow channel for carrying out the step of filling using a fluent substance selected from the group consisting of liquid reagents, cleaning solutions, solvents, and pesticides; and

the step of dispensing further comprises opening the valve, having been operatively arranged along a tubular extension in communication with the primary flow channel, long enough to dispense the pre-selected amount, and then closing the valve to temporarily prevent further dispensing of the fluent substance.

10

24. A method of transporting a fluent substance for dispensing during a test process, comprising the steps of:

providing a vessel comprising: flexible walls made of a material compatible with the fluent substance; an outwardly-facing indicia; and an upper end and a lower portion having at least one port in communication with a primary flow channel and a valve;

filling the vessel, for the transporting, with the fluent substance at a filling site that is separate from the test process;

orienting the vessel by a support framework; and

dispensing through the valve independent of the support framework, as needed, a pre-selected amount of the fluent substance contained in the vessel.

20

25. The method of claim 24 wherein:

the step of providing further comprises hermetically forming the upper end and a lower end of the lower portion into flexible sheet material;

the step of filling uses a fluent substance selected from the group consisting
5 of liquid reagents, cleaning solutions, solvents, and pesticides; and

the step of dispensing further comprises measuring the pre-selected amount with a flowmeter device operatively arranged upstream of the valve.

26. The method of claim 24 wherein:

10 the step of providing further comprises including a second flow channel, in communication with a second port of the upper end, for carrying out the step of filling; and

further comprising the steps of permanently blocking the second flow channel once the vessel has been filled and controlling inventory of the fluent
15 substance using an alphanumeric coding of the indicia.

27. The method of claim 24 wherein the step of providing further comprises hermetically forming the upper end and a lower end of the lower portion into polymeric sheet material such that a volume of the vessel is formed between the
20 ends having a capacity greater than that required to contain the pre-selected amount; and

a plug-in assembly comprising the primary flow channel and the valve for insertion into the port prior to the step of dispensing.

28. The method of claim 24 wherein the step of orienting further comprises inserting at least a portion of a projection of the framework through a support opening integrated within the upper end; and further comprising the step of, prior to the step of dispensing, rolling a base of the support framework to locate the support
5 framework within the test process for the step of dispensing.

29. The apparatus of claim 1 wherein the upper end and the lower end of the lower portion have been hermetically formed into polymeric sheet material such that: a volume of the vessel is formed between the ends having a capacity greater
10 than that required to contain the pre-selected amount; and the valve is operatively arranged at the at least one port.

30. The apparatus of claim 13 wherein: the indicia comprises alphanumeric coding for inventory control of the fluent substance, a portion of the indicia is
15 machine-readable for transmission to a remote processor; and the valve is operatively arranged at the at least one port.

31. The method of claim 19 wherein: the step of providing further comprises hermetically forming the upper end and a lower end of the lower portion from polymeric tubular stock material; the step of dispensing further comprises opening the valve, having been operatively arranged at the at least one port in
5 communication with the primary flow channel, long enough to dispense the pre-selected amount, and then closing the valve to temporarily prevent further dispensing of the fluent substance.

32. The method of claim 24 wherein the step of providing further comprises
10 hermetically forming the upper end and a lower end of the lower portion from polymeric tubular stock material such that a volume of the vessel is formed between the ends having a capacity greater than that required to contain the pre-selected amount; and the step of dispensing further comprises opening the valve, having been operatively arranged at the at least one port in communication with the
15 primary flow channel, long enough to dispense the pre-selected amount, and then closing the valve to temporarily prevent further dispensing of the fluent substance.

1/9

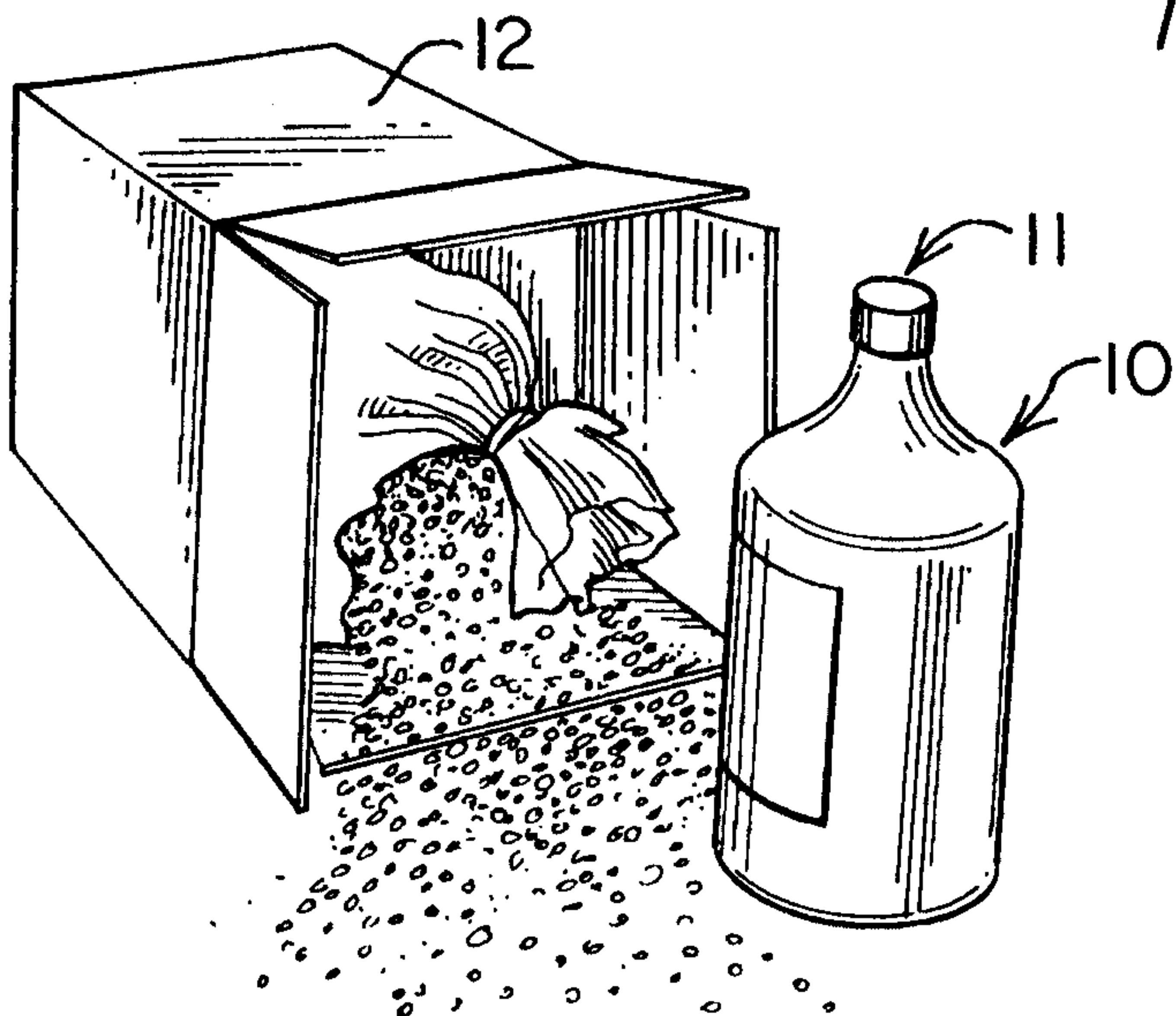

FIG. 1 (PRIOR ART)

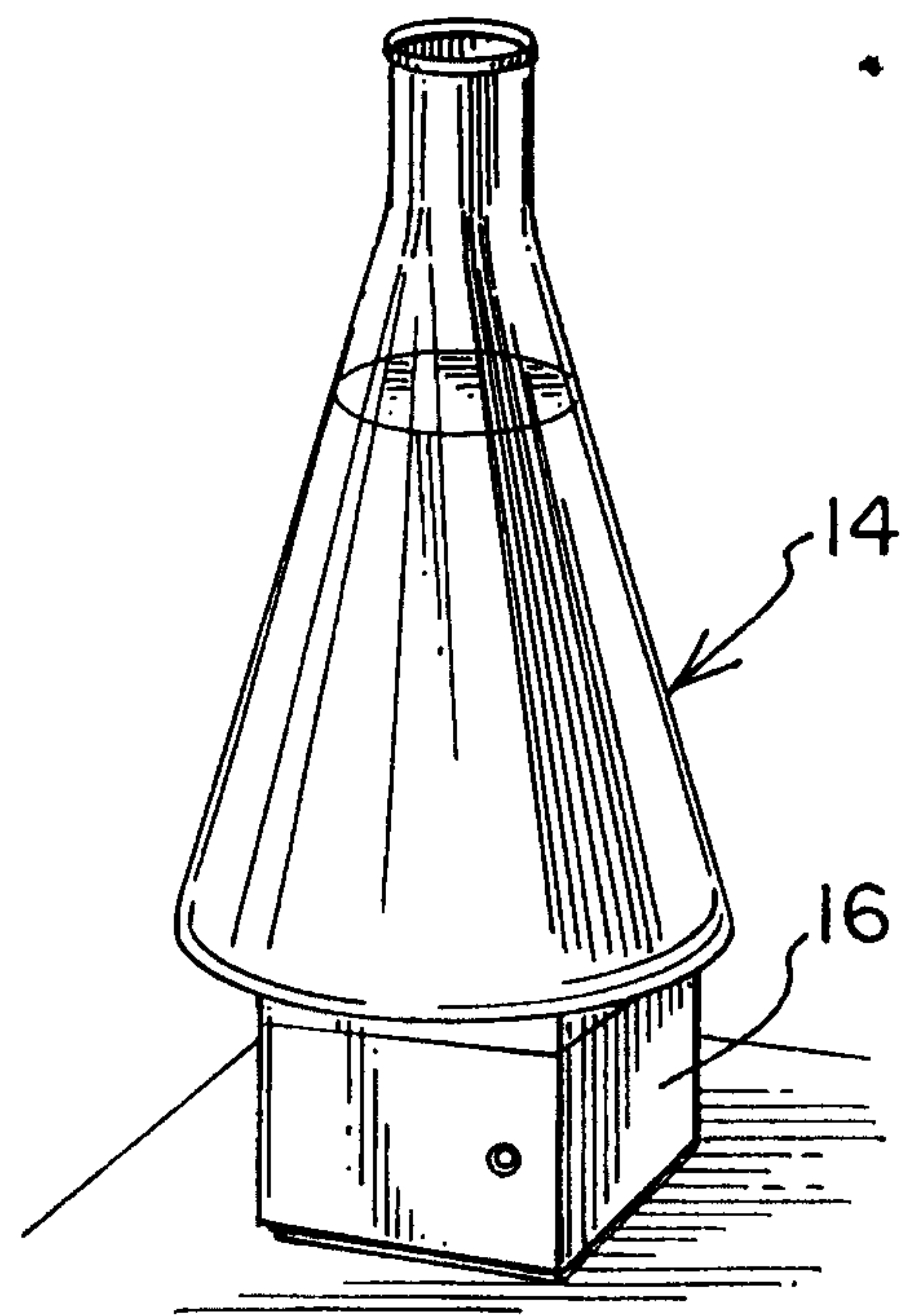

FIG. 2 (PRIOR ART)

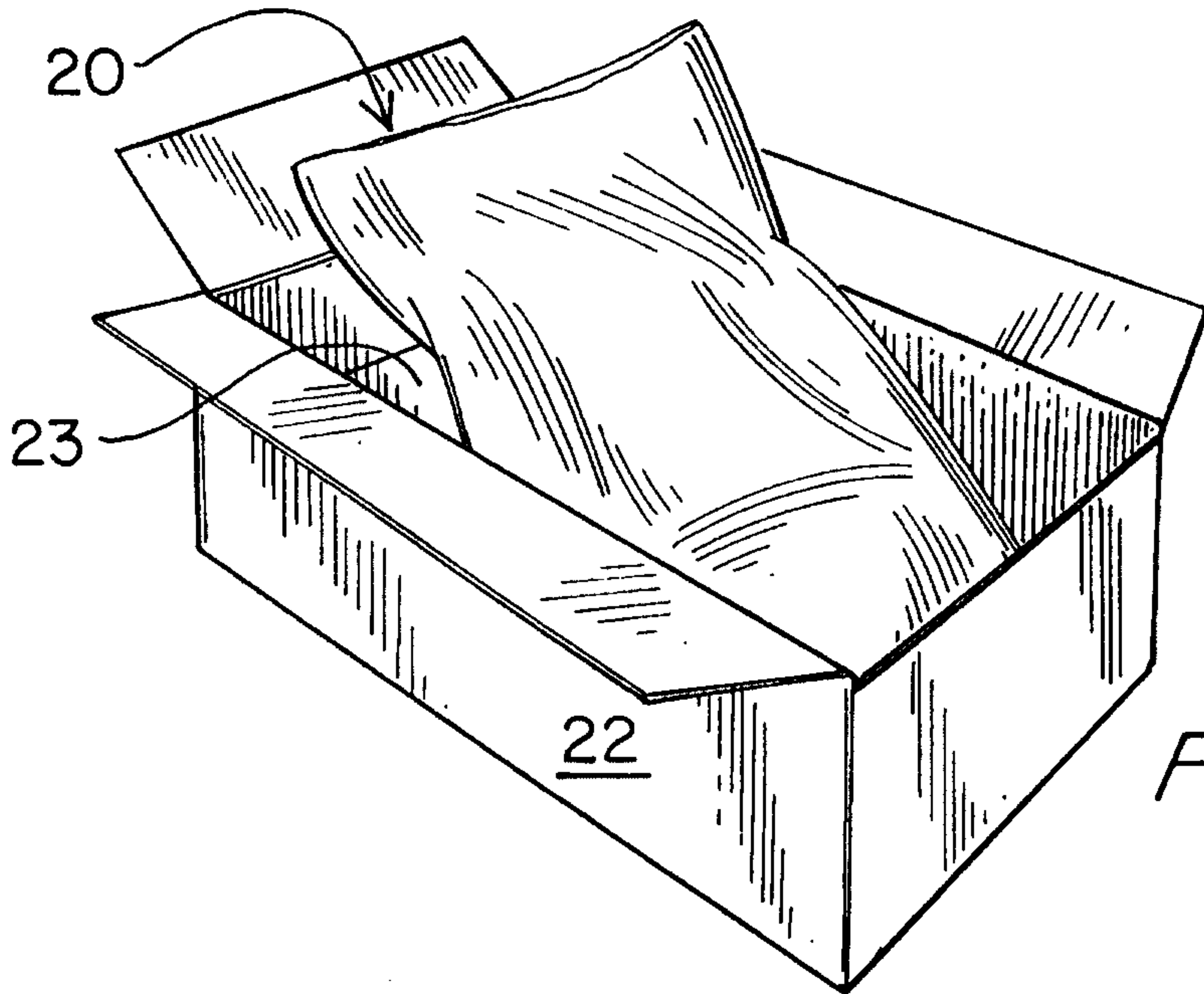

FIG. 3

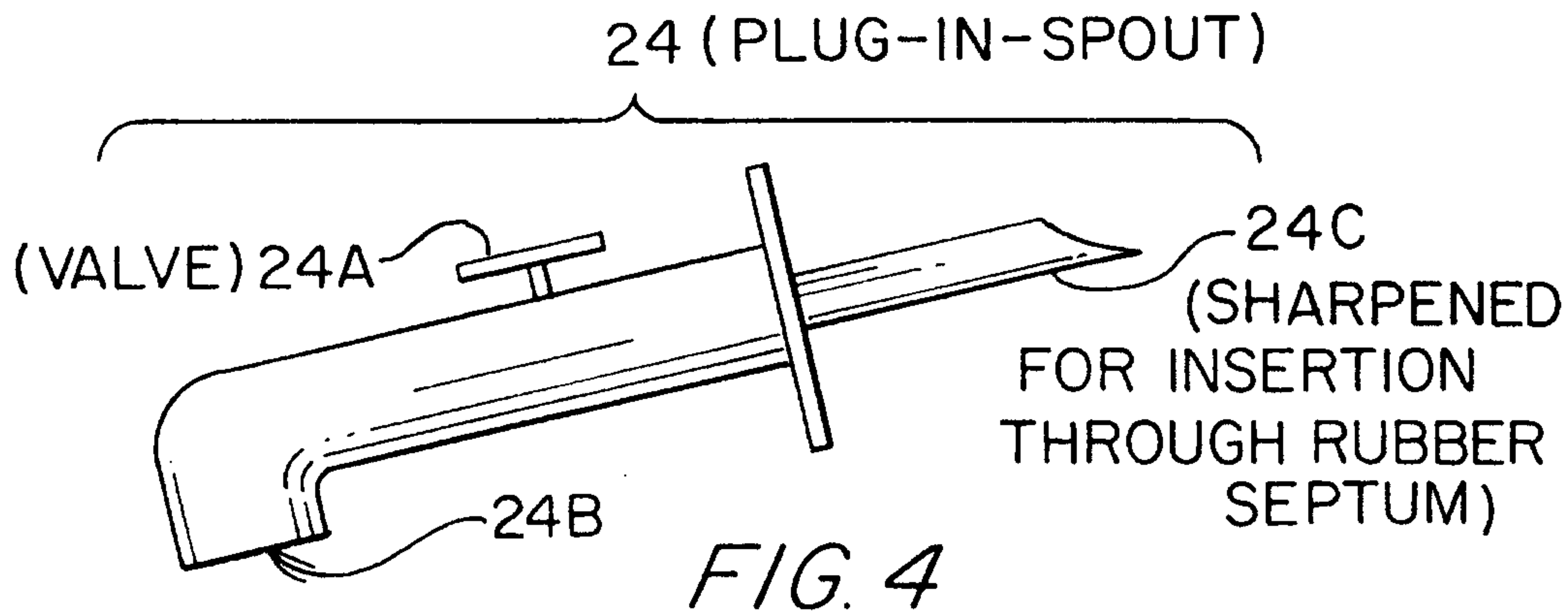
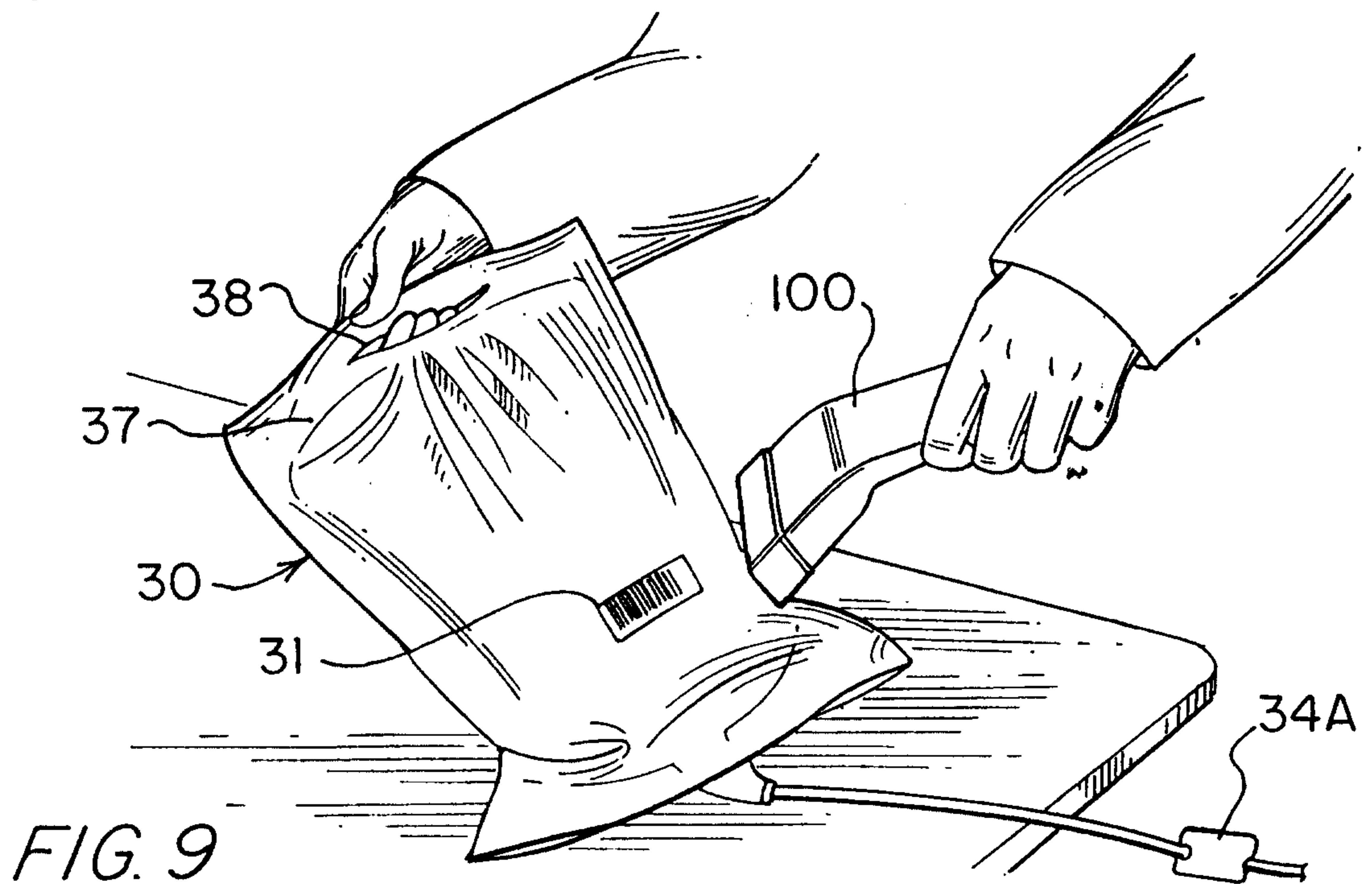
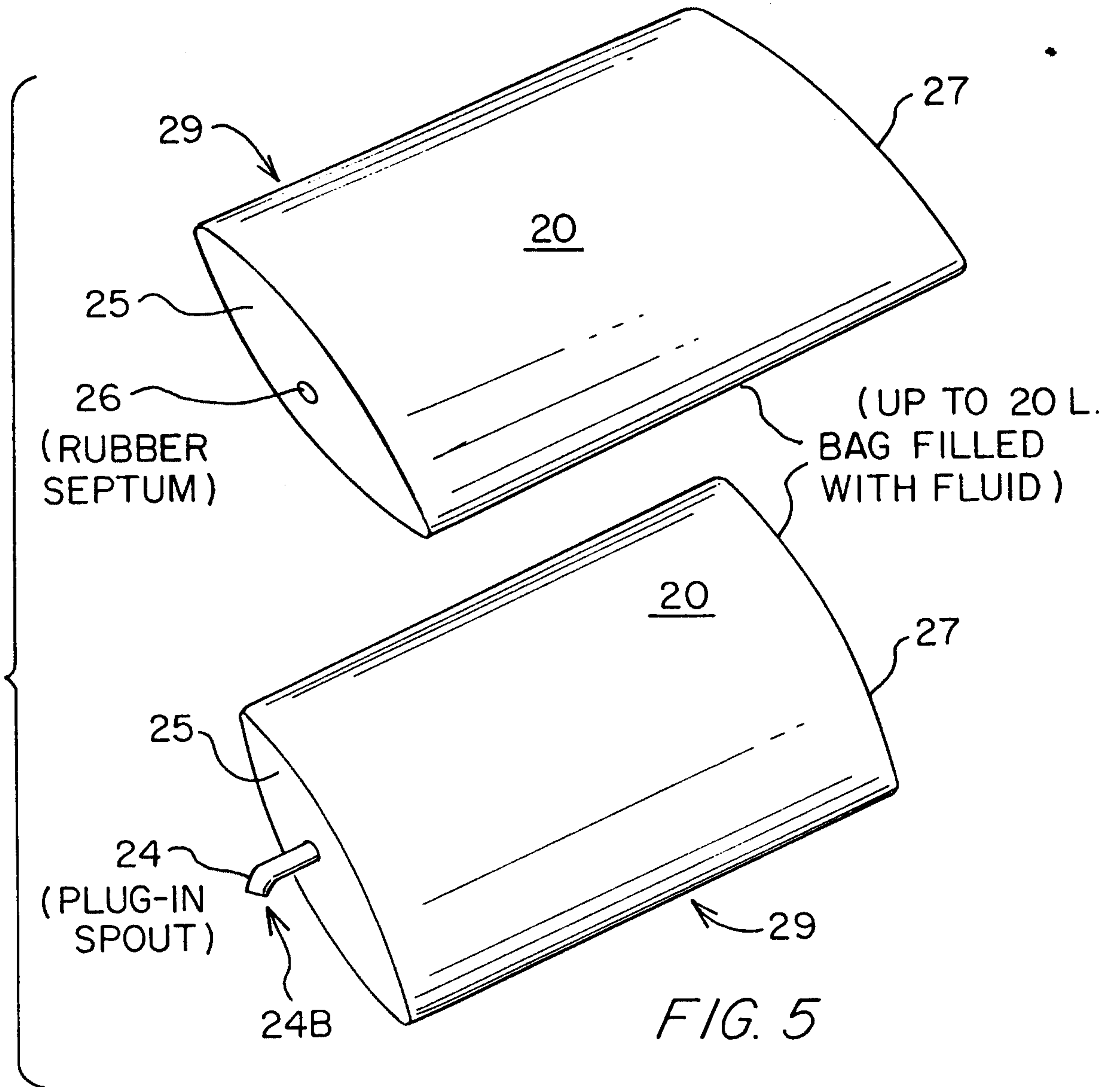

FIG. 4

2/9



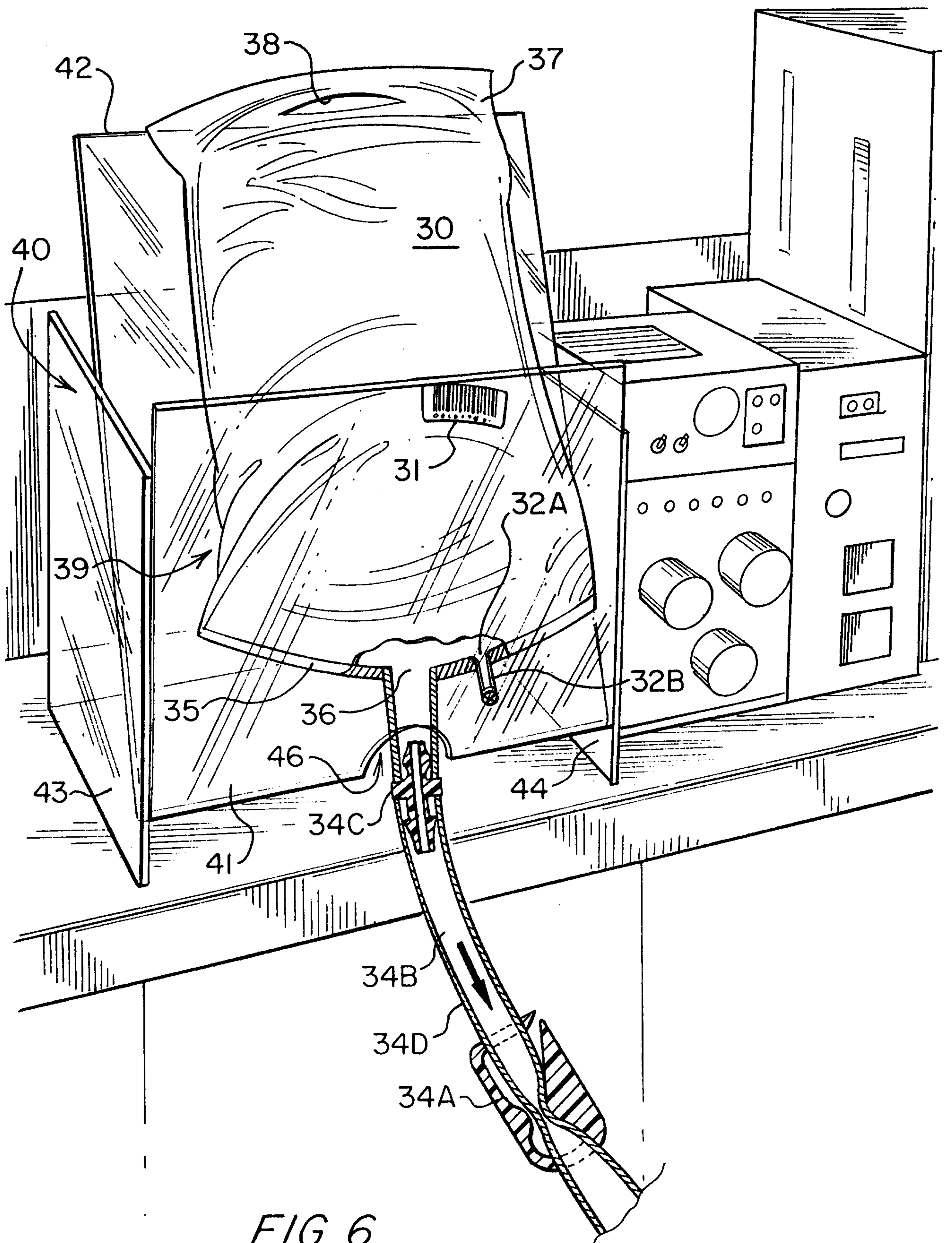

FIG. 6

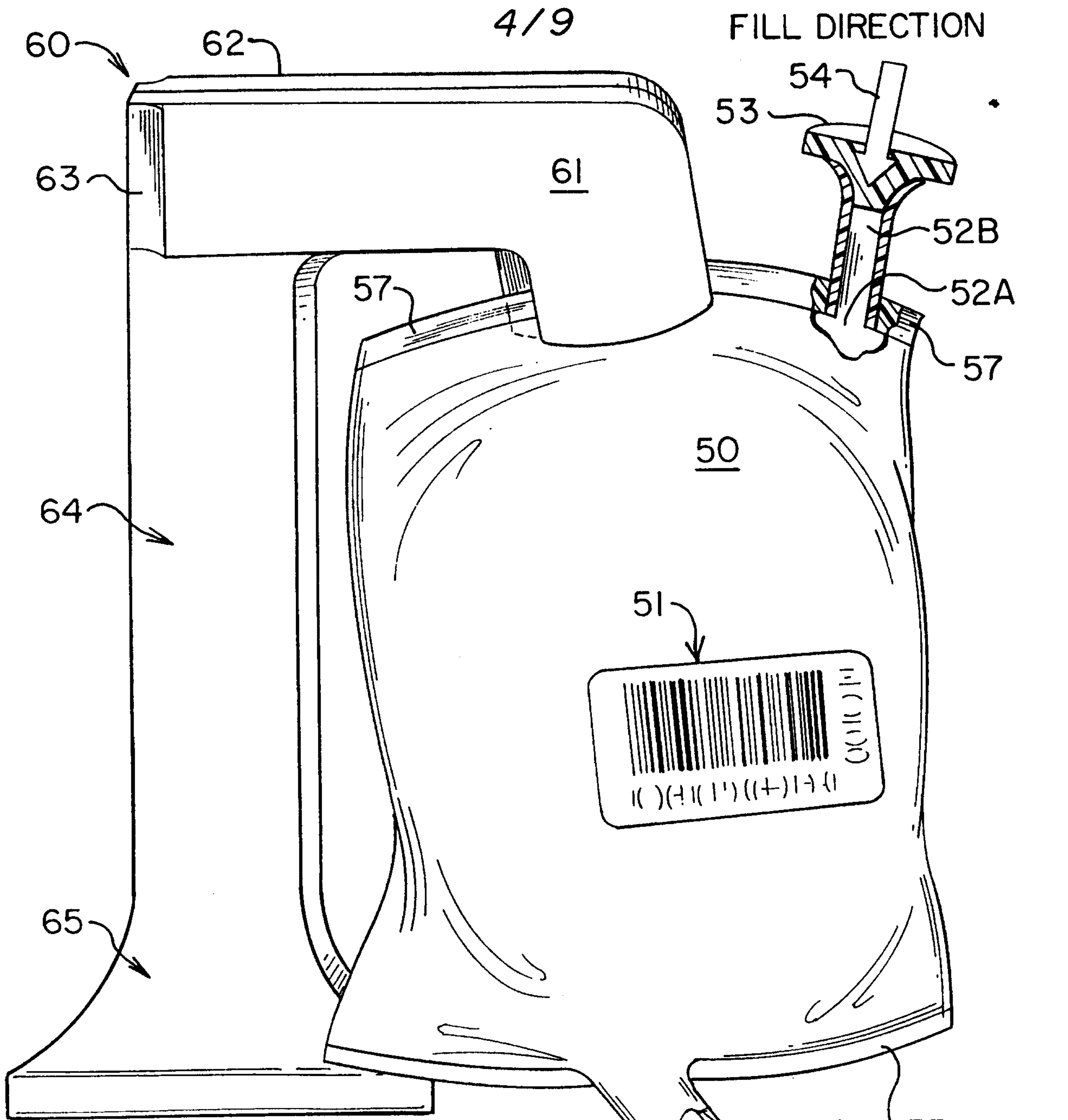

FIG. 7

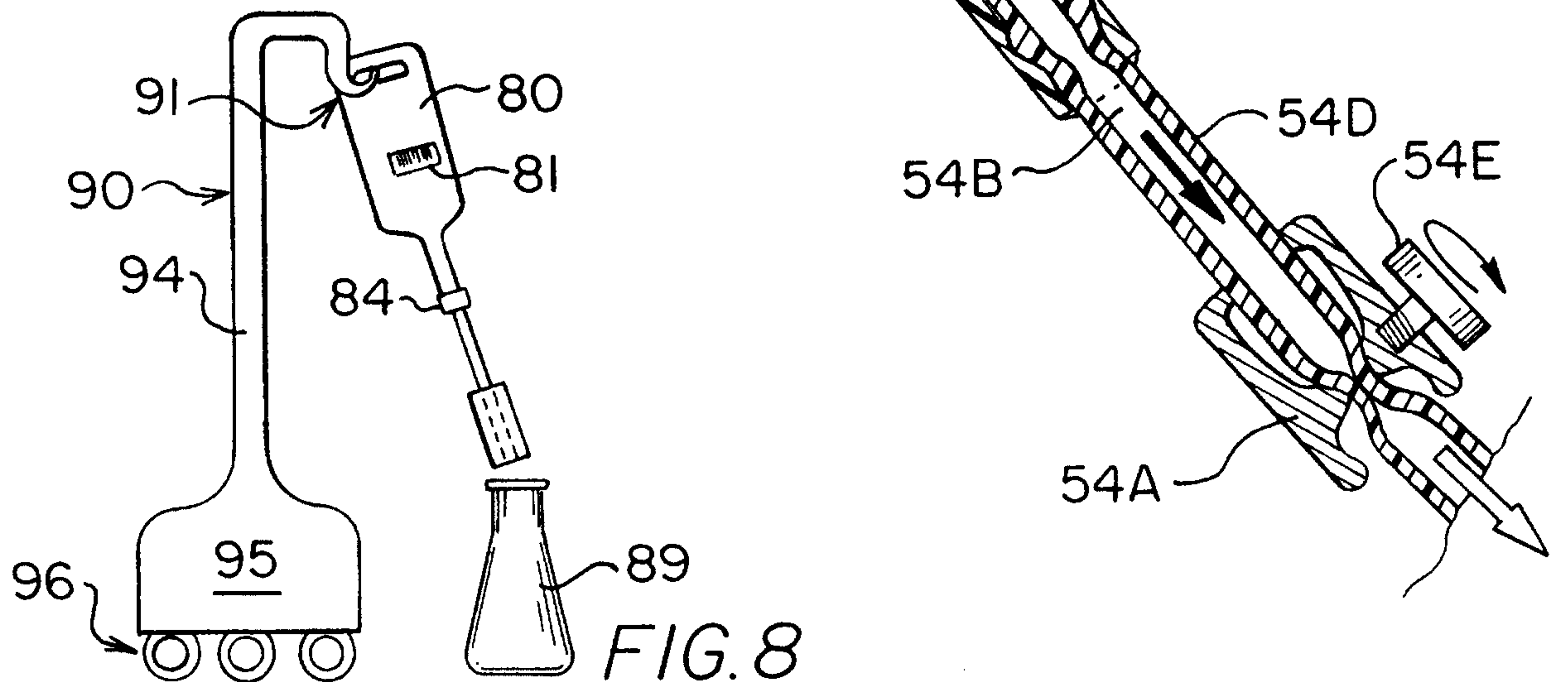

FIG. 8

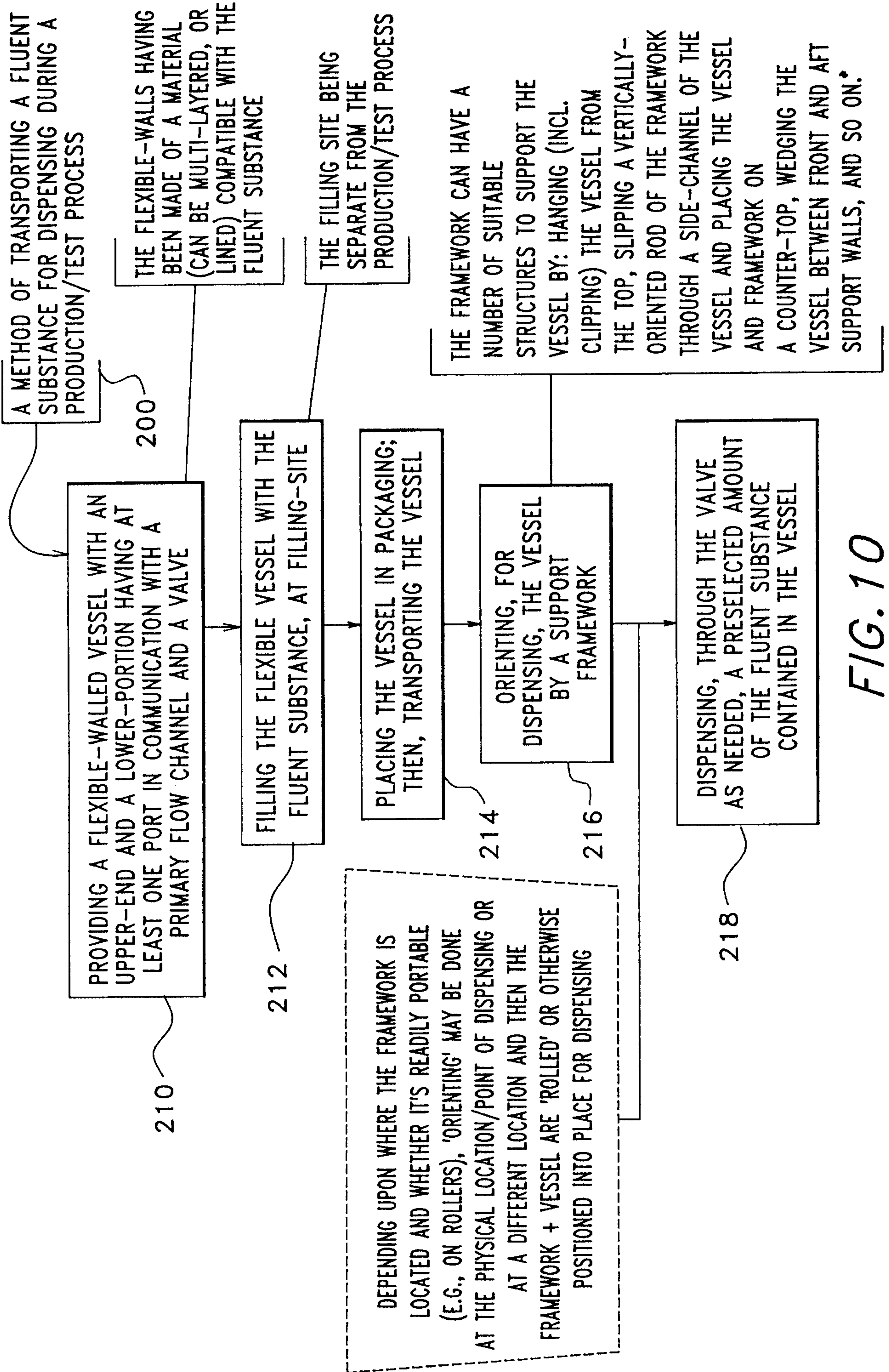
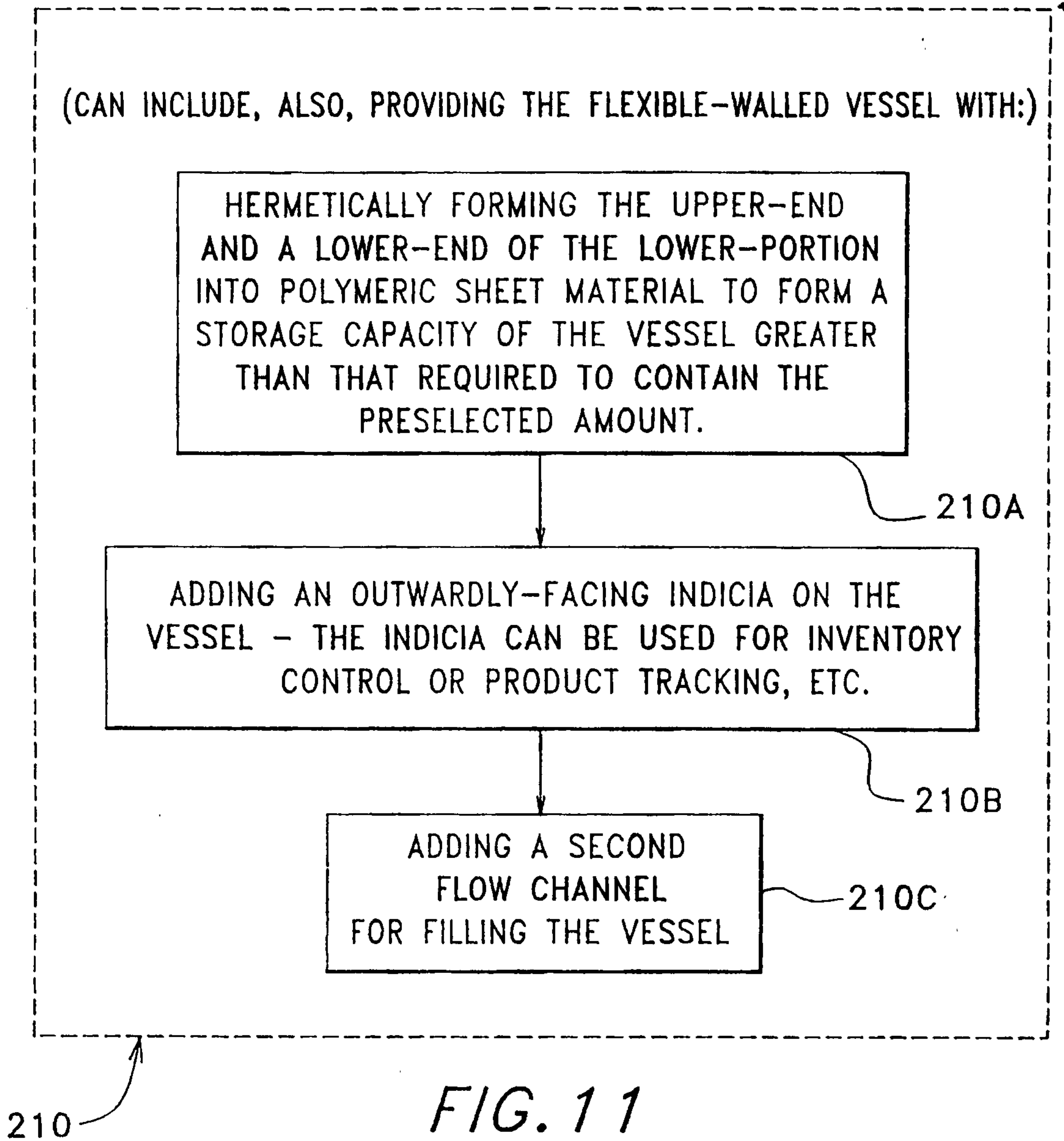

FIG. 10

6/9



7/9

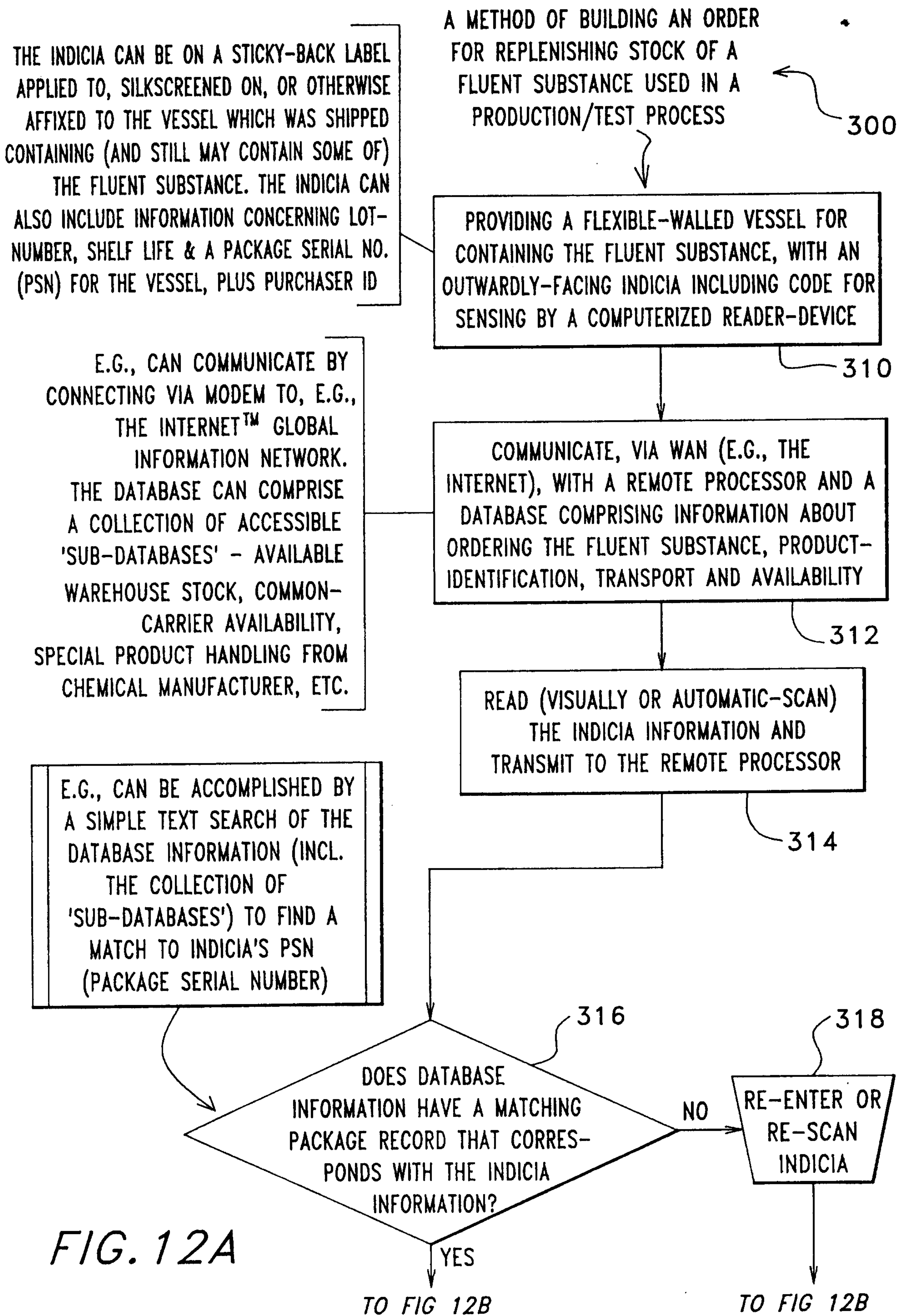

FIG. 12A

8/9

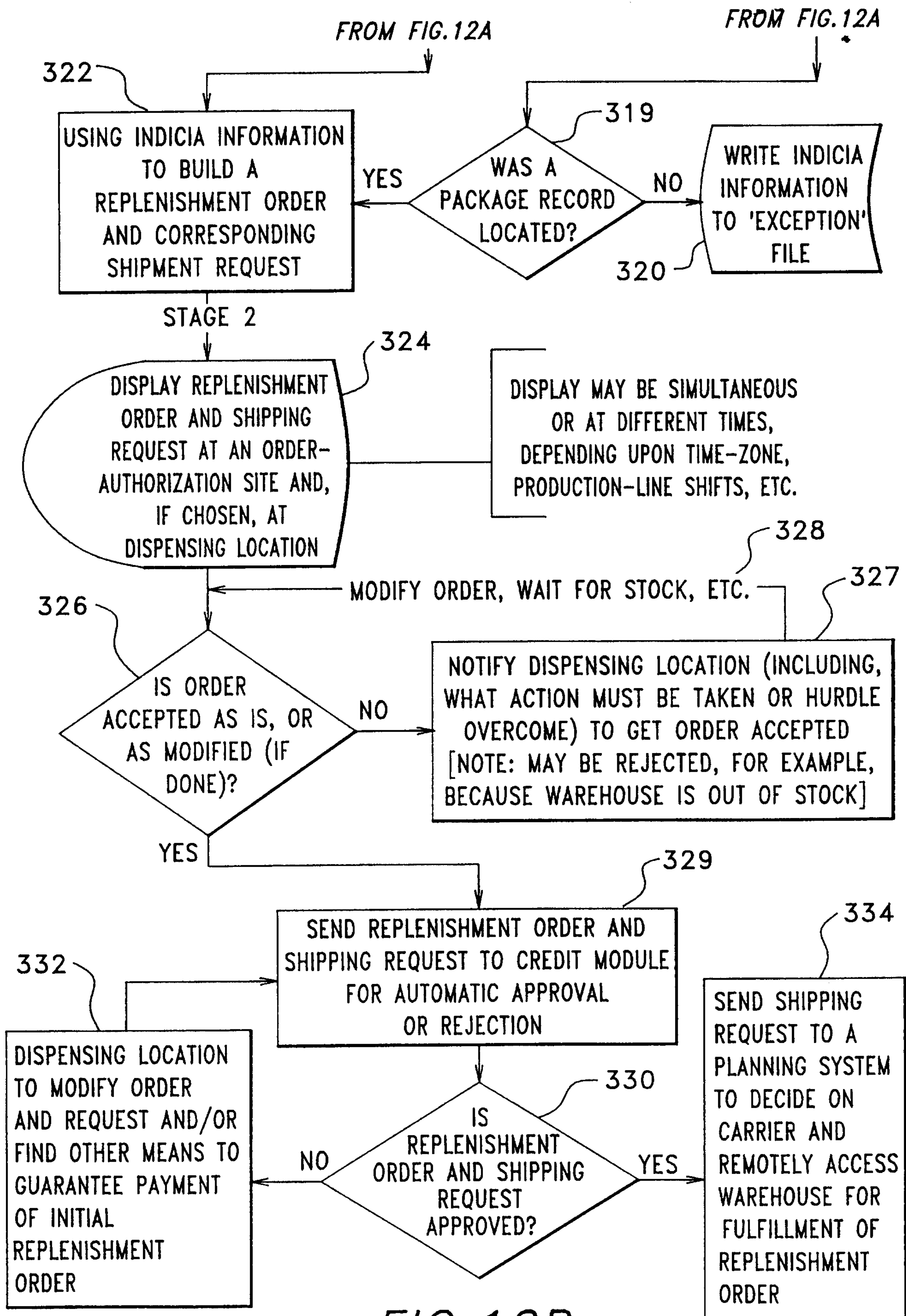

FIG. 12B

SUBSTITUTE SHEET (RULE 26)

9/9

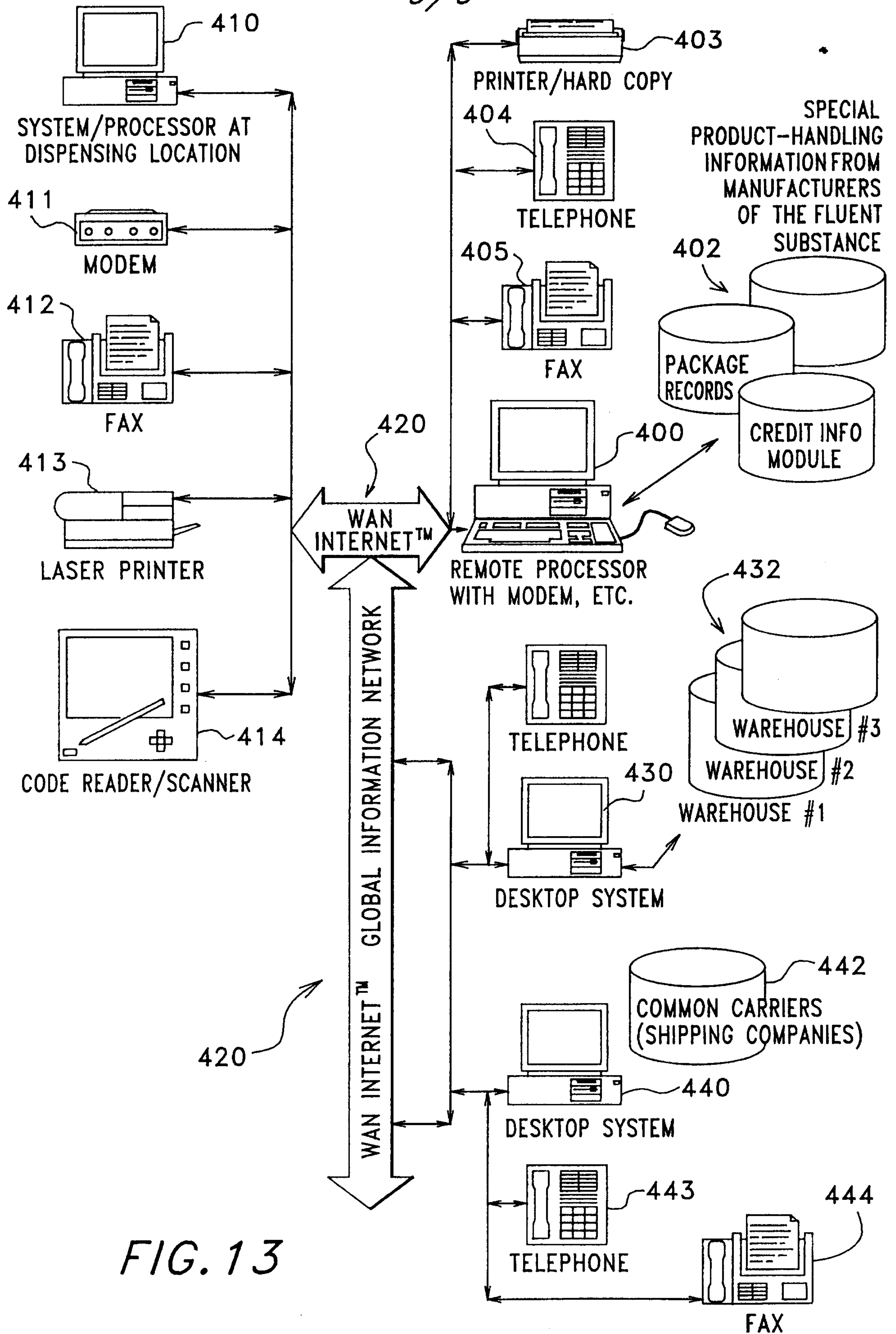

FIG. 13

