

(No Model.)

4 Sheets—Sheet 1.

W. LEWIS.
GAG BLOCK.

No. 458,990.

Patented Sept. 1, 1891.

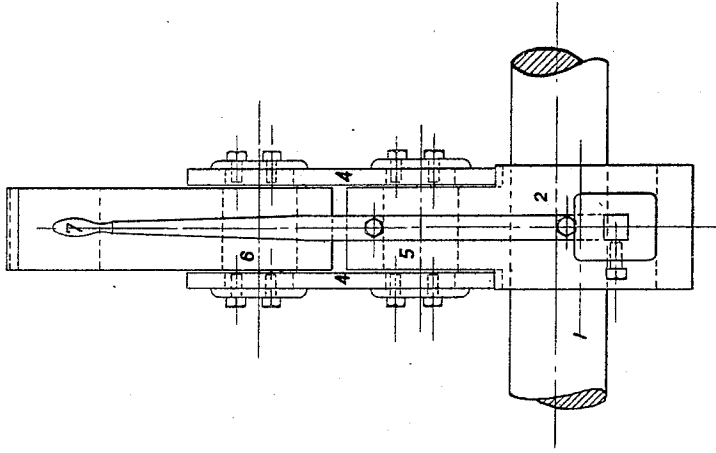

FIG 2

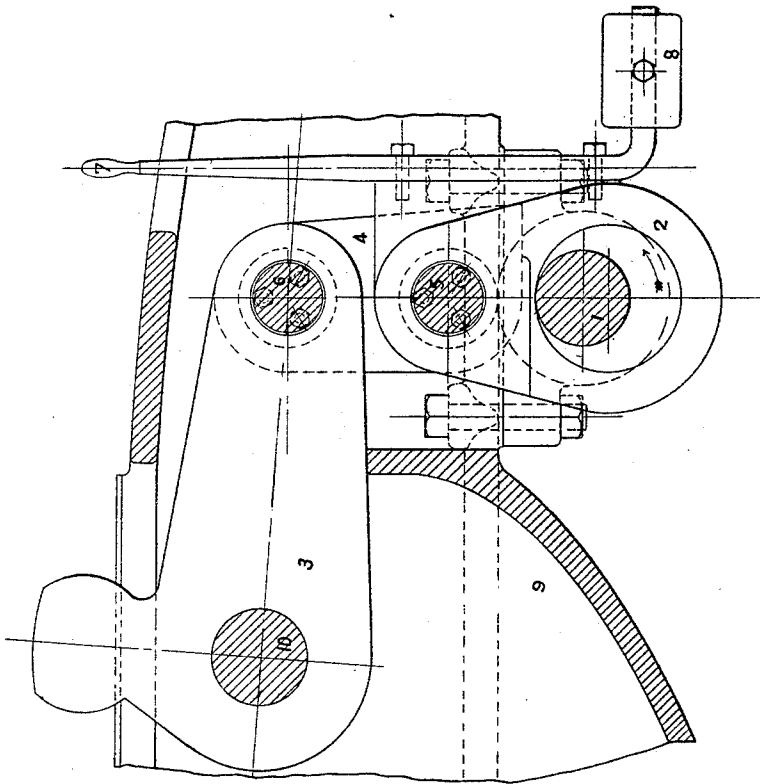

FIG 1

WITNESSES:

John L. Phillips
E. P. Harper

INVENTOR

Wilfred Lewis

(No Model.)

4 Sheets—Sheet 2.

W. LEWIS.
GAG BLOCK.

No. 458,990.

Patented Sept. 1, 1891.

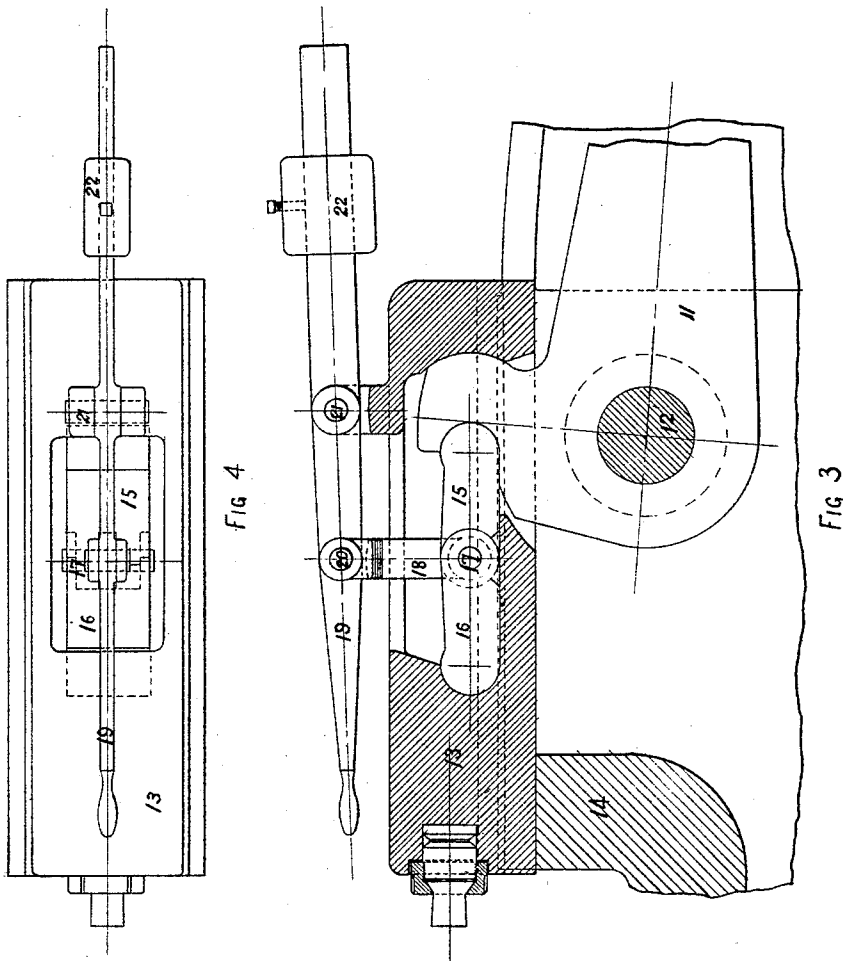

WITNESSES:
John B. Phillips
E. Harper

INVENTOR
Wilfred Lewis

W. LEWIS.
GAG BLOCK.

No. 458,990.

Patented Sept. 1, 1891.

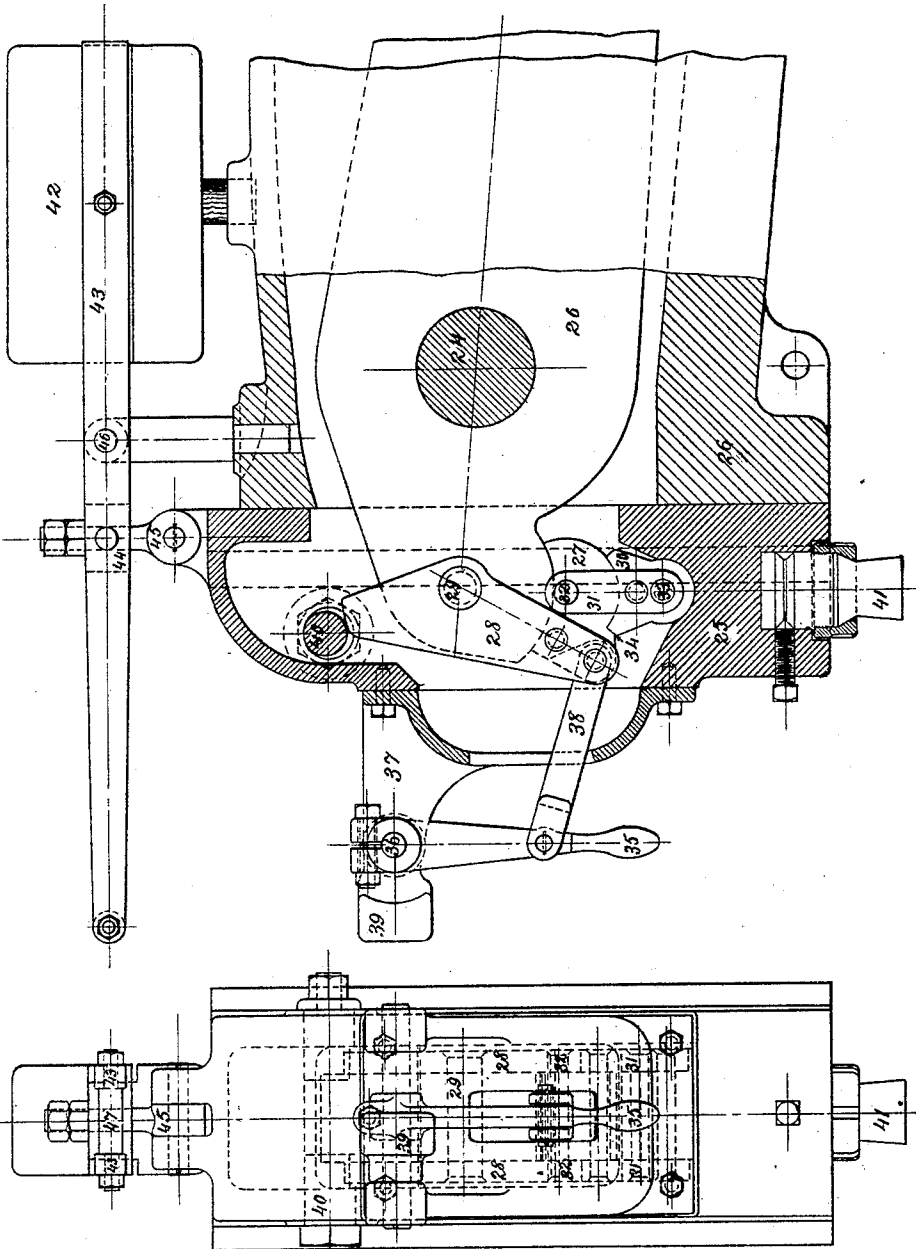

Fig. 5.

Fig. 6.

WITNESSES:

John L. Phillips
E. R. Harper

INVENTOR

Wilfred Lewis

(No Model.)

4 Sheets—Sheet 4.

W. LEWIS.
GAG BLOCK.

No. 458,990.

Patented Sept. 1, 1891.

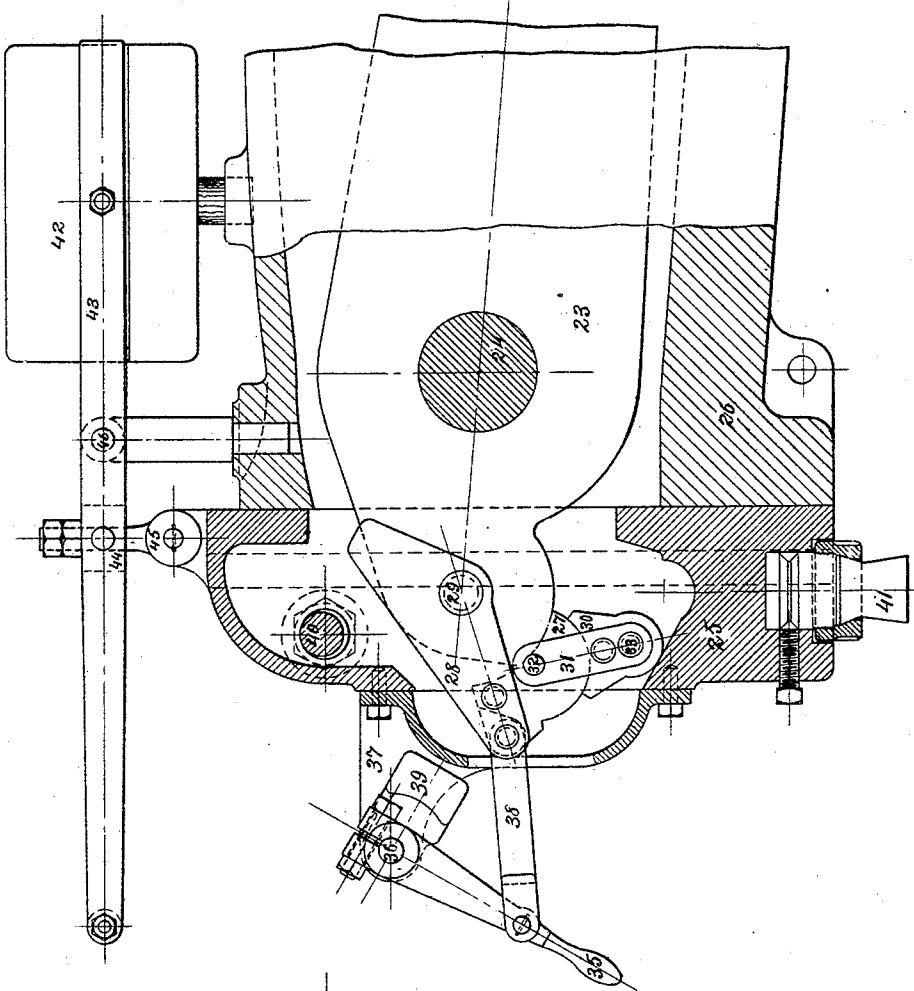

Fig. 7.

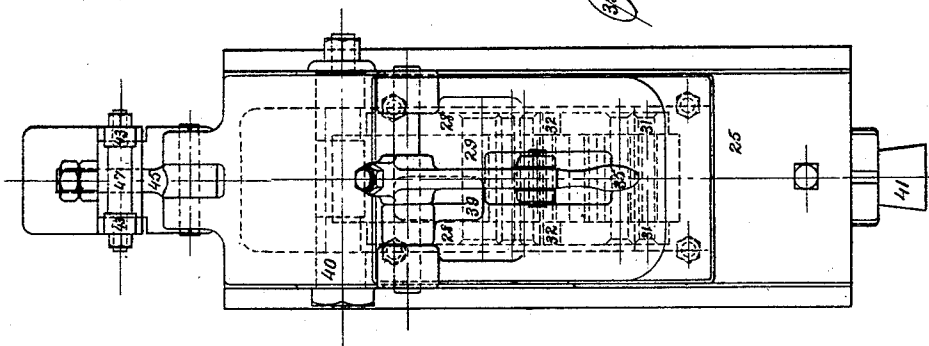

Fig. 8.

WITNESSES:
John L. Phillips
E. A. Harper

INVENTOR
Wilfred Lewis

UNITED STATES PATENT OFFICE.

WILFRED LEWIS, OF PHILADELPHIA, PENNSYLVANIA, ASSIGNOR TO WILLIAM SELLERS & COMPANY, INCORPORATED, OF SAME PLACE.

GAG-BLOCK.

SPECIFICATION forming part of Letters Patent No. 458,990, dated September 1, 1891.

Application filed February 20, 1891. Serial No. 382,268. (No model.)

To all whom it may concern:

Be it known that I, WILFRED LEWIS, of the city and county of Philadelphia and State of Pennsylvania, have invented a new and useful Improvement in Gag-Blocks, of which improvement the following is a specification.

My invention relates to that class of machinery in which one part of a mechanism having a reciprocating motion drives another part through the intervention of a distance-piece commonly known as a "gag-block," which may be inserted or withdrawn at pleasure to effect or to prevent the action of the driven part. Devices of this kind usually consist of a prismatic block about equal in thickness to the lost motion required and arranged to be inserted between the end of a pitman and the head which it drives, familiar examples of which may be noted in certain types of punching and shearing machines, and in connection with such types my invention is illustrated by the drawings. The gag-block may be withdrawn at any time during the return stroke of the pitman, and having been withdrawn the pitman travels forward in the space which is left by the block without moving the driven head. To bring the head again into action, an opportunity occurs at the end of each return stroke of the pitman to insert the gag-block. This is not always an easy matter to perform, as the gag-blocks are frequently large heavy pieces to sustain great pressure and the time allowed is short, while the distance the block must travel in such cases is great. The operation of the gag-block under these circumstances is attended with great risk, for if only partially inserted it may be crushed by the pressure concentrated at one edge and the operator may be injured by its flying fragments.

To remedy these defects, it is an object of my invention to provide ample bearing-surface for the gag-block whenever it operates the driven part.

It is a further object of my invention to operate the gag-block with greater ease and to avoid the danger of flying fragments by preventing a partially-inserted gag-block from crushing.

It is a further object of my invention to obtain a positive drawback which may be dis-

connected at will, leaving the driven head free to be adjusted by hand; and to these ends my invention consists of a gag-block in two parts united by a hinge-joint.

It further consists of a hinge-joint between the driving-bar or the eccentric and the adjacent part of the gag-block.

It further consists of a hinge-joint between the driven piece and the adjacent part of the gag-block.

It further consists of a stop on the driven head and a lug on the gag-block to withdraw the driven head when in action or leave it free to be moved by hand when out of action.

My invention may appear in a great variety of forms differing in detail, but maintaining throughout the general aspect of a toggle-joint, which the gag-block resembles in construction, while differing from it radically in function. This difference should be clearly understood, for while the toggle-joint is used as a means for applying pressure my present invention is used simply as a means for transmitting it.

In the accompanying drawings, which form part of this specification, Figure 1 is a sectional elevation of the gag-block as applied to a horizontal punching-machine between the eccentric and punching-lever. Fig. 2 is an end elevation of Fig. 1. Fig. 3 is a sectional elevation of the gag-block as applied to a horizontal punching-machine between the punching-lever and punching-head. Fig. 4 is a plan view of Fig. 3. Fig. 5 is a sectional elevation of the gag-block as applied to a vertical punching-machine, showing the position of the gag-block when in action. Fig. 6 is an end elevation of Fig. 5. Fig. 7 is a sectional elevation of the same gag-block when out of action, allowing the punching-head to be moved up or down by hand. Fig. 8 is an end elevation of Fig. 7.

In Figs. 1 and 2 the punching-lever is driven by the gag-block, while in Figs. 3, 4, 5, 6, 7, and 8 the punching-lever drives the gag-block, which in turn drives the punching-head.

It will be understood from these illustrations that my gag-block is as well adapted to a machine in which the punching-head is driven directly by an eccentric as it is to a

machine in which the punching-head is driven through an intervening lever.

In Figs. 1, 2, 3, and 4 the gag-block is represented in its simplest form, while in Figs. 5, 6, 7, and 8 it is modified for the purpose of disconnecting the punching-head.

Referring to Figs. 1 and 2, 1 is the eccentric-shaft or the reciprocating driver turning continuously in a given direction and driving the eccentric-strap 2, which forms one part of the gag-block. The eccentric-strap 2 is connected to the punching-lever or movable follower 3 by the links 4 4 and pins 5 and 6, which links 4 4 and pins 5 and 6 form the other part of the gag-block. The links 4 4 stop against shoulders on the eccentric-strap when the three centers 1, 5, and 6 come into line. 7 is an operating-lever bolted to the eccentric-strap 2 and carrying at one end a counter-weight 8. The eccentric-shaft turns in bearings bolted to the frame 9, to which the movable follower 3 is also connected by the pin 10. The movable follower 3 rests in its lowest position against a stop on the bed, and the three points 1, 5, and 6 are drawn into line, or nearly so, at each revolution of the eccentric. As the eccentric turns in the direction indicated by the arrow, the counter-weight 8 draws the point 5 out of line and the pin 6 remains stationary; but if the three points 1, 5, and 6 are held in line by the handle 7 the movable follower 3 will rise and fall continuously. It will be observed that in this gag-block the bearing-surface is the same, whether the gag-block is partially or wholly engaged, and if only partially engaged the joint 5 will simply yield, instead of driving the movable follower 3. When the eccentric and movable follower are pin-connected in this way to the gag-block, the drawback is positive, and the movable follower can be moved by hand only at regular intervals, because it must be in the position shown once in every revolution of the eccentric. It is not necessary, however, for the reciprocating driver and movable follower to be pin-connected, as shown in Figs. 1 and 2. The same result can be obtained without such pin-connections, as shown in Figs. 3 and 4. In this case the gag-block is not positively connected to either the driving or the driven piece. It is simply a hinged distance-piece with cylindrical end-bearings conveniently connected to an operating-handle.

Referring to Figs. 3 and 4, 11 is the punching-lever or reciprocating driver pivoted on the fulcrum-pin 12 and reciprocating thereon through a short angular movement. 13 is the punching-head or movable follower guided in the housing 14 and driven by the lever 11 through the intervening gag-block. 15 is part of the gag-block bearing against the lever 11 on a cylindrical surface, but not positively attached thereto. 16 is another part of the gag-block hinged to the first part 15 by the pin 17 and bearing against the movable follower 13 on a cylindrical surface, but

not positively attached thereto. 18 is a link conveniently attached to the gag-block by the pin 17 and to the operating-lever 19 by the pin 20. The operating-lever 19 is attached to the movable follower 13 by the fulcrum-pin 21 and extended back to carry the counter-weight 22. This counter-weight can be adjusted to lift the gag-block out of action or allow it to remain in action, as shown. When the counter-weight is set back to lift the hinge-joint of the gag-block, the punch can be operated at any time by pressing down the handle 19, and the movable follower 13 is returned to its original position by the direct action of the reciprocating driver 11. Here, also, as in Figs. 1 and 2, the movable follower may or may not move forward with the reciprocating driver; but having once moved forward it is always positively withdrawn by the return stroke of the reciprocating driver.

To disconnect the movable follower from the reciprocating driver, so that the follower may be moved at will without interfering with the driver and at the same time to retain the advantages of a hinged gag-block, the modification shown in Figs. 5, 6, 7, and 8 has been designed. Referring to Figs. 5, 6, 7, and 8, 23 is the punching-lever or reciprocating driver pivoted on the fulcrum-pin 24 and reciprocating thereon through a short angular movement. 25 is the punching-head or movable follower guided in the housing 26 and driven by the lever 23 through the intervening gag-block. 27 is part of the gag-block bearing against the lever 23 and hinged to it by the links 28 28 and the center pin 29. The links 28 28 are rigidly connected to the part 27 by the two pins shown, which are for convenience of construction only; but operatively 27 and 28 28 act as one piece and may be so constructed. The links 28 28 are extended above the pin 29 to act as a gag-block for raising the punching-head 25 when in the position shown in Fig. 3. 30 is another part of the gag-block hinged to the first part 27 by the links 31 31 and trunnions 32 32. The lower part of 30 is rounded off about the center 33 to form a cylindrical joint with the movable follower 25, and a shoulder is formed at 34 between 30 and 27 to keep the centers 29, 32, and 33 in line while in action. The links 31 31 and the part 30 act together as one piece in the same manner as the piece 27 and its links 28 28. 35 is an operating-handle pivoted at 36 to the stand 37, attached to the movable follower 25. 38 is a link connecting 27 and 35. 39 is a counter-weight turning on the shaft 36 and stopping against the lever 35 in two positions, as shown in Figs. 5 and 7. 40 is a pin attached to the movable follower 25, forming an abutment for the links 28 28 to withdraw the die 41 after punching. This pin is made eccentric at the contact-points for the purpose of taking up wear should any occur; but its purpose as an abutment would be served by a blocking-piece cast with the movable follower. 42 is a counter-

weight for the punching-head and connected with it by the bars 43 43, cross-bar 44, and link 45, the counter-weight and slide being supported by the fulcrum-pin 46. The bars 43 43 are extended and united by the handle 47, by which the die 41 can be adjusted to its work when the gag-block is set, as shown in Fig. 5. The action of the gag-block is here the same as in Figs. 1 and 2, except that it is not constantly connected with the driven piece. When the points 29, 32, and 33 are in line, the links 28 28 engage with the pin 40 and the movable follower will be driven positively in both directions; but when these points are out of line, as shown in Fig. 7, the links 28 28 are disconnected from the pin 40 and the head 25 is free to be moved by hand, while the lever 23 continues its reciprocating movement without disturbing the movable follower in whatever position this may be placed by the hand movement. The adjustment of the punch to a particular position on the work will then be uninterrupted by the reciprocating driver, an advantage not hitherto attained in gag-blocks. When the counter-weight 39 is set, as shown in Fig. 5, its weight will cause the gag-block to fall into action and the movable follower will reciprocate with the lever 23 and punch continuously; but when this counter-weight is set, as shown in Fig. 7, its weight will cause the gag-block to fall out of action, and the hand-lever 35 must be used whenever it is desired to punch. By means of the link 45 the movable follower can be adjusted to stop in any desired position when the gag-block is out of action, in which case the counter-weight 42 is made to slightly over-

balance the movable follower and rest against a permanent stop.

Having now described my invention, what I claim as new, and desire to secure by Letters Patent, is—

1. A gag-block in two parts united by a hinge-joint.
2. A gag-block in two parts united by a hinge-joint, in combination with a reciprocating driver and a movable follower, to which driver one of the parts is hinged.
3. A gag-block in two parts united by a hinge-joint, in combination with a reciprocating driver and a movable follower, to which the two parts of the gag-block are respectively hinged.
4. A gag-block in two parts united by a hinge-joint and a reciprocating driver hinged to one of the parts, in combination with a movable follower provided with a cylindrical joint, on which one of the parts of the gag-block can oscillate, and an abutment under which the other part locks, for the purpose specified.
5. A reciprocating driver provided with a hinged gag-block on one side and a swinging gag-block on the opposite side, in combination with a movable follower.
6. A gag-block in two parts united by a hinge-joint and a reciprocating driver hinged to one of the parts, in combination with a counter-weight, substantially as described.

WILFRED LEWIS.

Witnesses:

JOHN L. PHILLIPS,
E. R. HARPER.