



US00D881083S

(12) **United States Design Patent**
Blanski et al.

(10) **Patent No.:** **US D881,083 S**

(45) **Date of Patent:** **** Apr. 14, 2020**

- (54) **VEHICLE FRONT BUMPER**
- (71) Applicant: **GM GLOBAL TECHNOLOGY OPERATIONS LLC**, Detroit, MI (US)
- (72) Inventors: **Dillon R. Blanski**, Ferndale, MI (US);
Panayiotis J. Karras, Rochester, MI (US)
- (73) Assignee: **GM GLOBAL TECHNOLOGY OPERATIONS LLC**, Detroit, MI (US)
- (**) Term: **15 Years**
- (21) Appl. No.: **29/640,228**

- D605,083 S 12/2009 Manoogian, II et al.
- D605,977 S 12/2009 Zipfel et al.
- D605,978 S 12/2009 Wolff et al.
- D608,249 S 1/2010 Peters
- D608,690 S 1/2010 Folden et al.
- D608,691 S 1/2010 Zak, Jr. et al.
- D609,608 S 2/2010 Boniface et al.
- D611,387 S 3/2010 Thompson et al.
- D611,879 S 3/2010 Kim et al.
- D612,297 S 3/2010 Peters et al.
- D613,645 S 4/2010 Song et al.
- D615,458 S 5/2010 Thompson et al.
- D618,595 S 6/2010 Ware et al.
- D623,090 S 9/2010 Cox et al.
- D627,262 S 11/2010 Ikeda et al.
- D635,488 S 4/2011 Phipps
- D644,147 S 8/2011 Suh et al.
- D644,567 S 9/2011 Kozub

(Continued)

- (22) Filed: **Mar. 13, 2018**
- (51) **LOC (12) Cl.** **12-16**
- (52) **U.S. Cl.**
USPC **D12/169**
- (58) **Field of Classification Search**
USPC D12/86, 91, 93, 163, 164, 165, 166, 167,
D12/169, 171, 172, 173, 190, 216
CPC B60R 9/06; B60R 19/02; B60R 19/04; B60R
19/18; B60R 19/44; B60R 19/48; B62D
35/02; B62D 39/00; B62D 65/16; B62D
21/12; B29C 45/16
See application file for complete search history.

Primary Examiner — Susan Bennett Hattan
Assistant Examiner — Suzanne E Tisdell

(57) **CLAIM**

The ornamental design for a vehicle front bumper, as shown and described.

DESCRIPTION

FIG. 1 is a front and left perspective view of the vehicle front bumper according to the present disclosure; FIG. 2 is a front elevation view thereof; FIG. 3 is a left end elevation view thereof; and, FIG. 4 is a top plan view thereof.

The right end elevation view is omitted, because the right end elevation view is a mirror image to the left end elevation view.

The broken lines shown in the drawings depict portions of the vehicle front bumper that form no part of the claimed design.

The shade lines in the figures show contour and not surface ornamentation.

1 Claim, 4 Drawing Sheets

- (56) **References Cited**
U.S. PATENT DOCUMENTS
- 6,729,682 B2 * 5/2004 Delavalle B62D 25/08
296/193.08
- D570,742 S 6/2008 Takagi et al.
- D592,105 S 5/2009 Dean et al.
- D597,447 S 8/2009 Folden
- D600,595 S 9/2009 Nakamura et al.
- D601,925 S 10/2009 O'Donnell
- D603,755 S 11/2009 Peters
- D604,203 S 11/2009 O'Donnell
- D605,082 S 12/2009 Munson

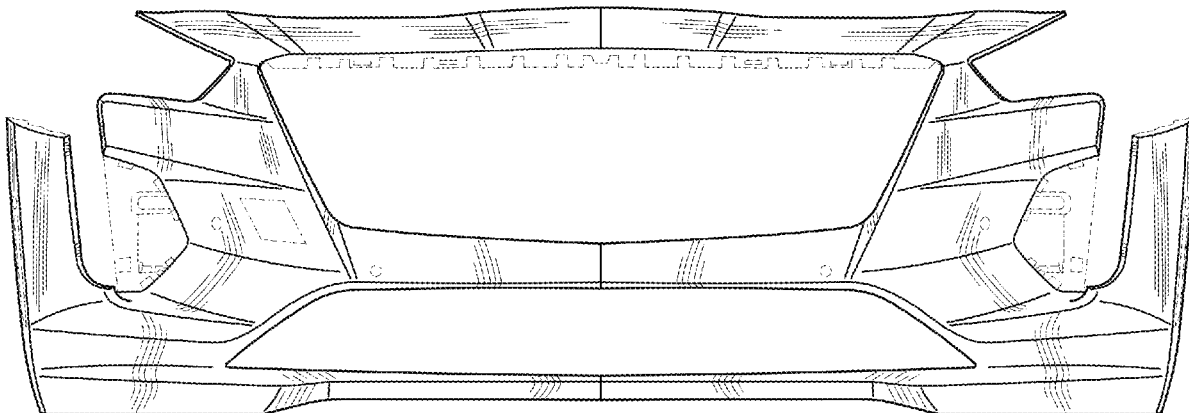

(56)

References Cited

U.S. PATENT DOCUMENTS

D657,718 S	4/2012	Zipfel et al.	D749,246 S	2/2016	Thole et al.
D659,052 S	5/2012	Ware et al.	D749,249 S	2/2016	Thole et al.
D659,053 S	5/2012	Ware et al.	D749,250 S	2/2016	Thole et al.
D668,182 S	10/2012	Barba Franco et al.	D749,985 S	2/2016	Kozub et al.
D668,183 S	10/2012	Smart	D749,997 S	2/2016	McMahan et al.
8,303,030 B2 *	11/2012	Baccouche B60R 19/24 296/203.01	D750,001 S	2/2016	Thole et al.
D678,820 S	3/2013	Son et al.	D753,032 S	4/2016	Smith et al.
D678,821 S	3/2013	Ikeda et al.	D753,033 S	4/2016	Thole et al.
D680,909 S	4/2013	Munson et al.	D753,034 S	4/2016	Thole et al.
D680,910 S	4/2013	David	D753,035 S	4/2016	Boniface et al.
D684,899 S	6/2013	Baker	D753,559 S	4/2016	McMahan et al.
D686,536 S	7/2013	McCabe et al.	D753,560 S	4/2016	McMahan et al.
D692,798 S	11/2013	Thurber	D753,567 S	4/2016	Boniface et al.
D692,799 S	11/2013	Smith et al.	D754,571 S	4/2016	Boniface et al.
D696,157 S	12/2013	Loeb	D754,572 S	4/2016	McMahan et al.
D699,629 S	2/2014	Ikeda et al.	D755,088 S	5/2016	McMahan et al.
D700,871 S	3/2014	O'Donnell et al.	D756,869 S	5/2016	McMahan et al.
D703,103 S	4/2014	Lee	D758,271 S	6/2016	McMahan et al.
D704,103 S	5/2014	Mack et al.	D764,975 S	8/2016	Aengenheyster
D705,132 S	5/2014	Ware et al.	D764,976 S	8/2016	Aengenheyster
D705,699 S	5/2014	Ware et al.	D767,449 S	9/2016	Pevarov et al.
D713,298 S	9/2014	Dyson	D767,450 S	9/2016	Lee et al.
D713,764 S	9/2014	Ferlazzo et al.	D767,451 S	9/2016	Kozub et al.
D715,708 S	* 10/2014	Mays D12/169	D767,454 S	9/2016	McMahan et al.
D715,709 S	* 10/2014	Matsumoto D12/169	D767,458 S	9/2016	Kim
D716,696 S	11/2014	Thole et al.	D767,459 S	9/2016	Kim
D716,706 S	11/2014	Thole et al.	D767,460 S	9/2016	Kozub et al.
D716,709 S	11/2014	Thole et al.	D767,461 S	9/2016	Kozub et al.
D717,696 S	11/2014	Thole et al.	D771,528 S	11/2016	Smith et al.
D718,189 S	11/2014	Krieg et al.	D771,529 S	11/2016	Thole et al.
D718,683 S	12/2014	Thole et al.	D771,532 S	11/2016	Kapitonov
D722,282 S	2/2015	Loeb	D771,533 S	11/2016	Kapitonov
D722,533 S	2/2015	Thole et al.	D772,118 S	* 11/2016	Schneider D12/169
D722,534 S	2/2015	Munson et al.	D772,766 S	11/2016	Kozub et al.
D724,510 S	3/2015	McMahan et al.	D772,767 S	11/2016	Kim
D725,001 S	3/2015	McMahan et al.	D773,084 S	11/2016	Kapitonov
D726,591 S	4/2015	Jacob	D773,086 S	11/2016	McCabe et al.
D730,776 S	6/2015	Smart	D774,226 S	12/2016	McCabe et al.
D730,783 S	6/2015	Henriques et al.	D775,003 S	12/2016	Pevarov et al.
D732,427 S	6/2015	Loeb	D775,007 S	12/2016	Thole et al.
D732,429 S	6/2015	Loeb	D775,010 S	12/2016	Kim et al.
D732,430 S	6/2015	Loeb	D775,049 S	12/2016	Scheer et al.
D732,431 S	6/2015	Loeb	D775,549 S	1/2017	Karras
D732,432 S	6/2015	Aengenheyster	D775,554 S	1/2017	Kapitonov
D732,433 S	6/2015	Aengenheyster	D776,020 S	1/2017	Kapitonov
D732,435 S	6/2015	Mackay	D776,581 S	1/2017	Pevarov et al.
D733,002 S	6/2015	Loeb	D776,583 S	1/2017	Scheer et al.
D735,611 S	8/2015	Aengenheyster	D776,841 S	1/2017	Kozub et al.
D735,627 S	8/2015	Smith	D776,843 S	1/2017	McCabe et al.
D736,451 S	8/2015	Smith	D776,846 S	1/2017	Willett et al.
D739,306 S	9/2015	McMahan	D777,359 S	1/2017	Kozub et al.
D739,317 S	9/2015	McMahan et al.	D777,360 S	1/2017	Kozub et al.
D741,223 S	10/2015	Kim et al.	D777,361 S	1/2017	Kozub et al.
D743,309 S	11/2015	Thole et al.	D777,604 S	1/2017	McNerney
D743,313 S	11/2015	Smith et al.	D777,605 S	1/2017	Ferlazzo et al.
D743,314 S	11/2015	Thole et al.	D777,620 S	1/2017	Pevarov et al.
D743,857 S	11/2015	McMahan et al.	D777,621 S	1/2017	Kim
D744,158 S	11/2015	Willett et al.	D777,622 S	1/2017	Kozub et al.
D745,086 S	12/2015	Finos et al.	D777,628 S	1/2017	Kozub et al.
D745,719 S	12/2015	Boniface et al.	D777,955 S	1/2017	Willett et al.
D745,725 S	12/2015	McMahan et al.	D778,212 S	2/2017	Kozub et al.
D745,726 S	12/2015	McMahan et al.	D778,215 S	2/2017	Kozub et al.
D745,837 S	12/2015	Smith et al.	D780,064 S	2/2017	Smith et al.
D746,726 S	1/2016	Smith et al.	D780,067 S	2/2017	Zipfel et al.
D746,727 S	1/2016	Smith et al.	D780,068 S	2/2017	Whitla et al.
D746,728 S	1/2016	Smith et al.	D780,077 S	2/2017	Kim et al.
D746,729 S	1/2016	Boniface et al.	D780,081 S	2/2017	Lee
D746,730 S	1/2016	Kim et al.	D780,084 S	2/2017	Scheer et al.
D747,514 S	1/2016	McMahan et al.	D780,631 S	3/2017	Kozub et al.
D747,515 S	1/2016	McMahan et al.	D780,644 S	3/2017	Kim et al.
D747,819 S	1/2016	Thole et al.	D781,184 S	3/2017	Thole et al.
D749,021 S	2/2016	Boniface et al.	D781,192 S	3/2017	Kozub et al.
D749,026 S	2/2016	Smith et al.	D782,379 S	3/2017	Wassell
D749,027 S	2/2016	McMahan et al.	D783,482 S	4/2017	Smith et al.
			D784,213 S	4/2017	Karras
			D784,223 S	4/2017	Lee
			D784,226 S	4/2017	Cheng
			D784,579 S	4/2017	Cheng et al.
			D784,877 S	4/2017	Lee

(56)

References Cited

U.S. PATENT DOCUMENTS

D784,886 S	4/2017	Smith et al.	D794,230 S	8/2017	Kozub
D785,521 S	5/2017	Smith et al.	D795,747 S	8/2017	Bailie
D786,149 S	5/2017	Pevovar et al.	D795,757 S	8/2017	Pevovar et al.
D786,743 S	5/2017	Smith et al.	D795,758 S	8/2017	Karras
D786,750 S	5/2017	Lee	D795,759 S	8/2017	Kozub et al.
D787,446 S	5/2017	Cockerill	D795,760 S	8/2017	Kozub et al.
D787,984 S	5/2017	Fang	D795,762 S	8/2017	Lee
D787,988 S	5/2017	Lee	D795,763 S	8/2017	Kozub
D787,989 S	5/2017	Kozub et al.	D796,088 S	8/2017	McCabe et al.
D787,990 S	5/2017	Kozub et al.	D796,093 S	8/2017	Mainville
D787,992 S	5/2017	Lee	D796,390 S	9/2017	Pevovar et al.
D787,993 S	5/2017	McCabe et al.	D797,537 S	9/2017	Cooper et al.
D788,001 S	5/2017	Lee	D797,603 S	9/2017	Noone et al.
D788,641 S	6/2017	Arnold	D797,614 S	9/2017	Lee
D788,644 S	6/2017	Mueller	D797,616 S	9/2017	Lee
D788,645 S	6/2017	Mueller	D797,624 S	9/2017	Nakamura
D788,657 S	* 6/2017	Oohashi D12/169	D797,625 S	9/2017	Perkins
D789,250 S	6/2017	Arnold	D797,631 S	9/2017	Pevovar et al.
D789,260 S	6/2017	Smith et al.	D797,632 S	9/2017	Zipfel et al.
D789,575 S	6/2017	Willett	D797,967 S	9/2017	Barry
D789,841 S	6/2017	Lee	D797,970 S	9/2017	Mainville
D789,849 S	6/2017	Lee	D797,971 S	9/2017	Mainville
D791,018 S	7/2017	Mylenek	D797,972 S	9/2017	Whitla et al.
D791,644 S	7/2017	Fang	D798,204 S	9/2017	Mainville
D792,290 S	7/2017	Smith et al.	D799,384 S	10/2017	Kozub et al.
D792,293 S	7/2017	McCabe et al.	D799,385 S	10/2017	Kozub et al.
D792,294 S	7/2017	McCabe et al.	D799,386 S	10/2017	Kozub et al.
D792,295 S	7/2017	McCabe et al.	D799,728 S	10/2017	Whitla et al.
D792,815 S	7/2017	Kozub	D801,237 S	* 10/2017	Jang D12/169
D792,816 S	7/2017	Kozub	D801,883 S	* 11/2017	Fujiwara D12/169
D793,290 S	8/2017	Kozub	D803,738 S	* 11/2017	Granlund D12/169
D793,292 S	8/2017	Lee	D807,249 S	* 1/2018	Piscitelli D12/169
D793,293 S	8/2017	Lee et al.	D807,250 S	* 1/2018	Piscitelli D12/169
D793,294 S	8/2017	Lee	D807,254 S	* 1/2018	Piscitelli D12/169
D793,295 S	8/2017	McCabe et al.	D807,257 S	* 1/2018	Piscitelli D12/169
D793,296 S	8/2017	Smith et al.	D807,799 S	* 1/2018	Kimura D12/169
D793,297 S	8/2017	Smith et al.	D809,981 S	* 2/2018	Seo D12/169
D793,299 S	8/2017	Kreig et al.	D811,289 S	* 2/2018	Bucher D12/169
D793,300 S	8/2017	Kreig et al.	D811,291 S	* 2/2018	Ishigaki D12/169
D793,301 S	8/2017	Kozub	D811,964 S	* 3/2018	Perkins D12/169
D793,302 S	8/2017	Kozub	D813,740 S	* 3/2018	Park D12/169
D793,311 S	8/2017	Whitla et al.	D814,369 S	* 4/2018	Loeb D12/169
D793,590 S	8/2017	Kozub et al.	D816,566 S	* 5/2018	Loeb D12/169
D793,591 S	8/2017	Kozub et al.	D817,235 S	* 5/2018	Bucher D12/169
D793,917 S	8/2017	Kozub	D817,826 S	* 5/2018	Seo D12/169
D793,918 S	8/2017	Kozub	D819,517 S	* 6/2018	Arai D12/169
D794,229 S	8/2017	Barry	D819,529 S	* 6/2018	Szavits D12/173
			D820,174 S	* 6/2018	Whitla D12/169

* cited by examiner

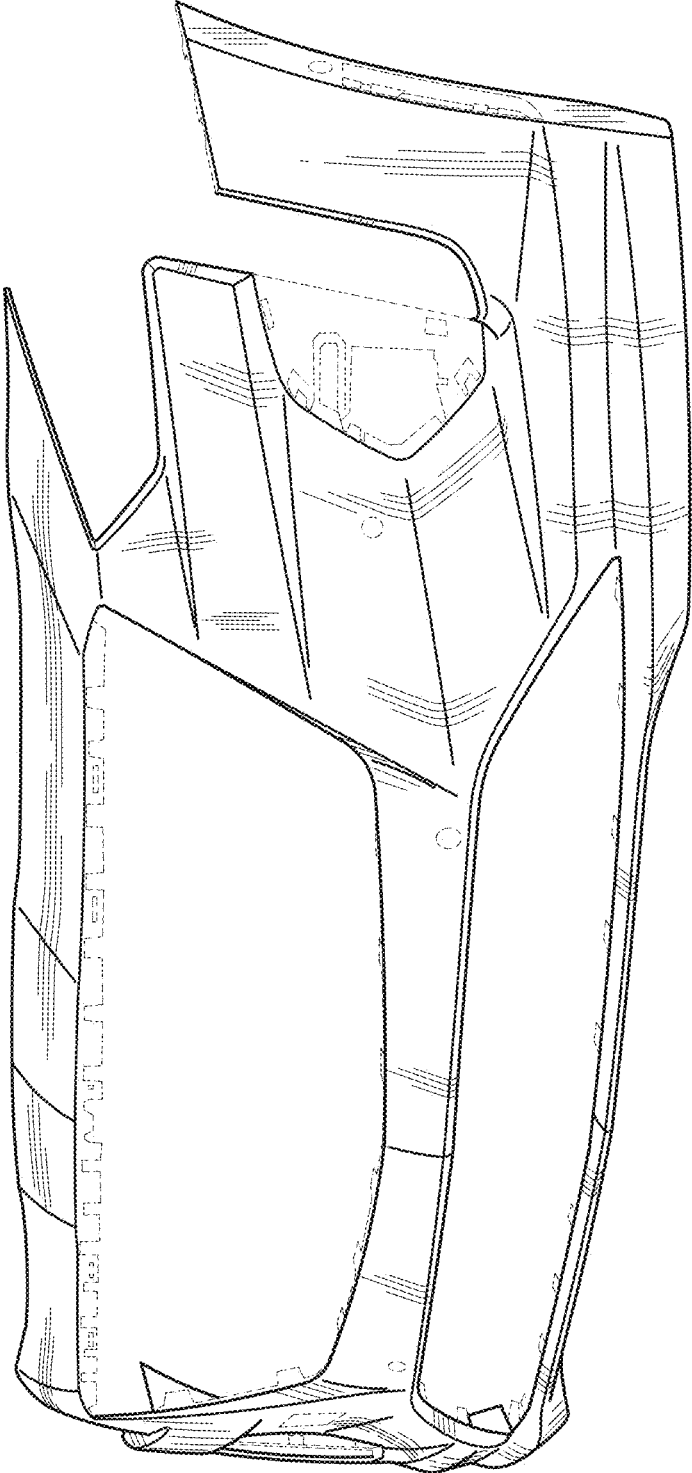

FIG - 1

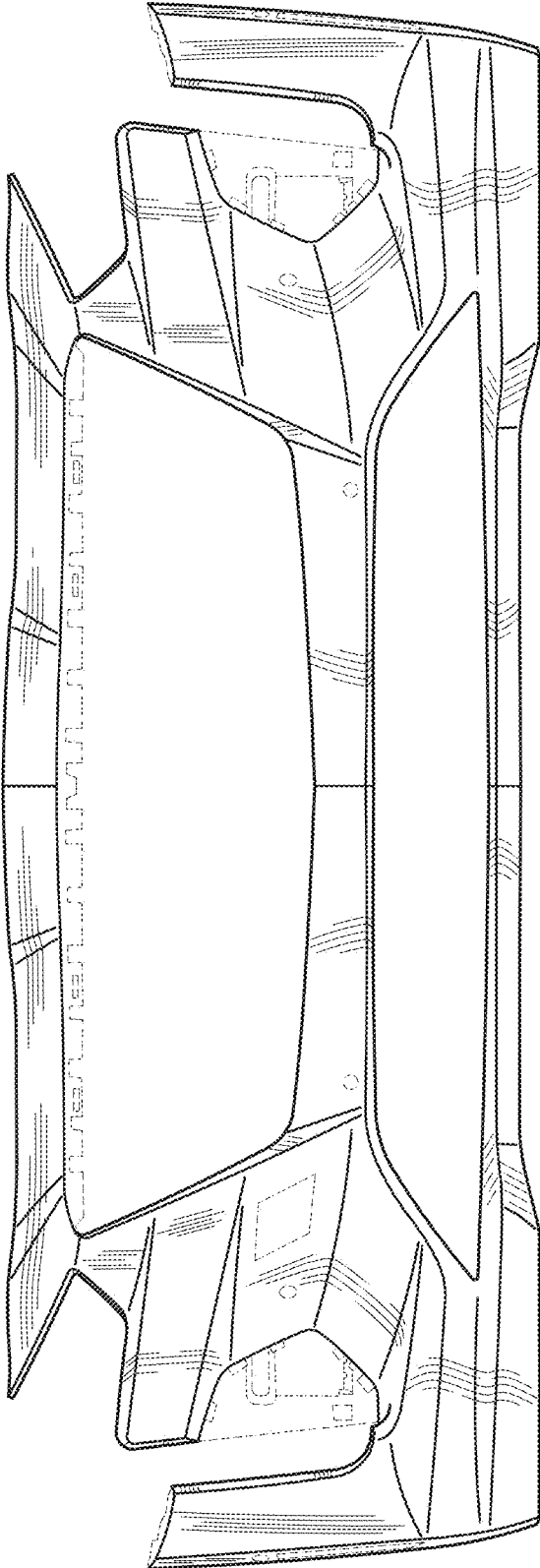

FIG-2

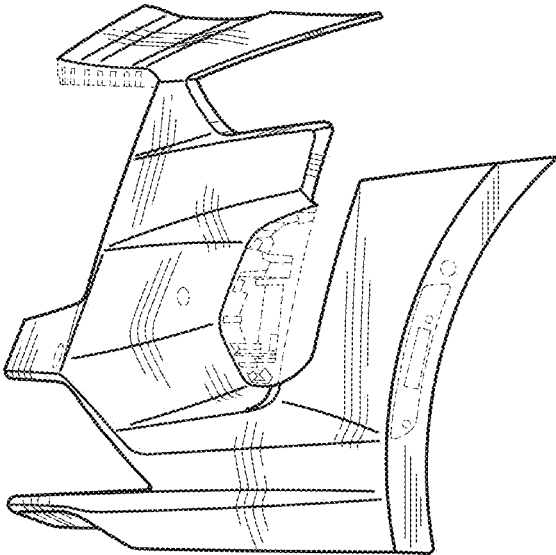

FIG - 3

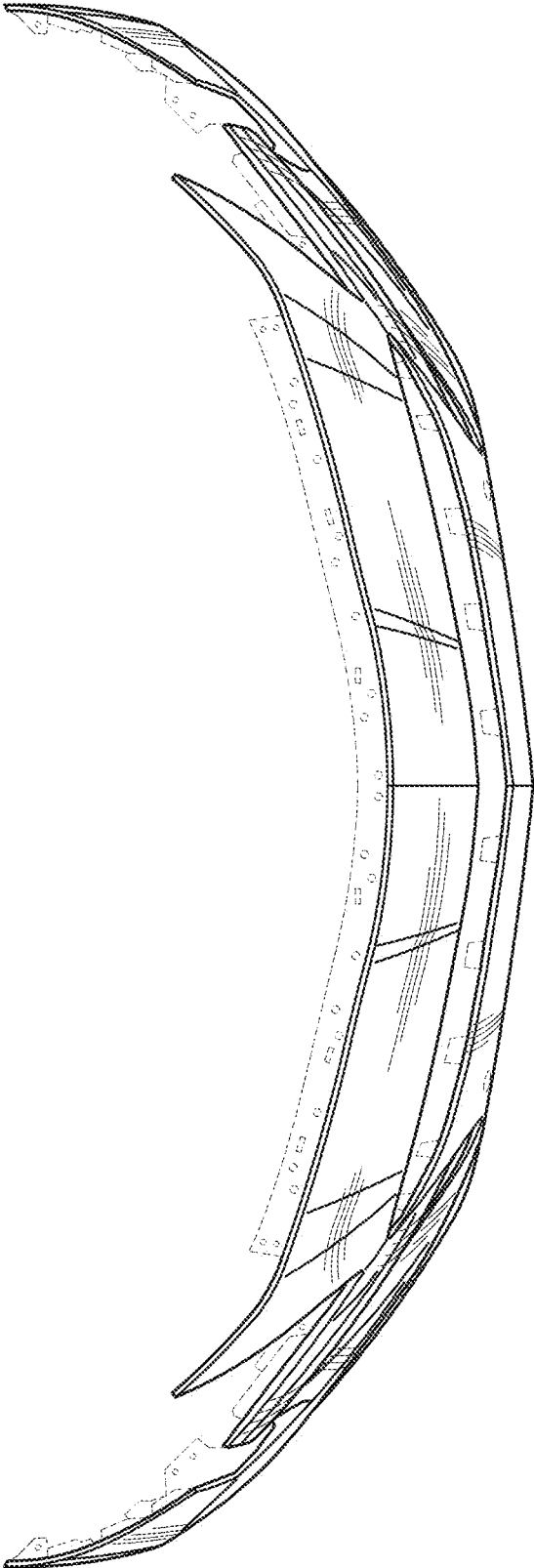

FIG - 4