



US 20050277492A1

(19) **United States**

(12) **Patent Application Publication** (10) **Pub. No.: US 2005/0277492 A1**

**Nye et al.**

(43) **Pub. Date: Dec. 15, 2005**

(54) **SUPPORT POLE FOR A BASKETBALL SYSTEM**

(52) **U.S. Cl. .... 473/481**

(76) **Inventors: S. Curtis Nye, Clinton, UT (US);  
David C. Winter, Layton, UT (US);  
Robert A. Astle, Farmington, UT (US);  
Carl R. Stanford, Clinton, UT (US)**

(57) **ABSTRACT**

Correspondence Address:  
**WORKMAN NYDEGGER  
(F/K/A WORKMAN NYDEGGER & SEELEY)  
60 EAST SOUTH TEMPLE  
1000 EAGLE GATE TOWER  
SALT LAKE CITY, UT 84111 (US)**

A support pole for a basketball system is preferably adjustable in height to allow a basketball goal to be located at various heights. The support pole may include a first section and a second section that are movable relative to each other. An adjustment assembly may hold the first and second support pole sections in a generally fixed position and allow the support pole sections to be moved, which may allow the height of the basketball goal to be adjusted. The adjustment assembly may include, for example, one or more surfaces that frictionally abut or contact one or more support pole sections. The adjustment assembly may also include one or more structures that are inserted into openings, apertures, detents or the like to secure the support pole at a desired length. In addition, the adjustment assembly may include a handle, trigger or the like to allow the length of the support pole to be adjusted.

(21) **Appl. No.: 11/085,284**

(22) **Filed: Mar. 21, 2005**

**Related U.S. Application Data**

(60) **Provisional application No. 60/555,528, filed on Mar. 22, 2004.**

**Publication Classification**

(51) **Int. Cl.<sup>7</sup> ..... A63B 63/08**

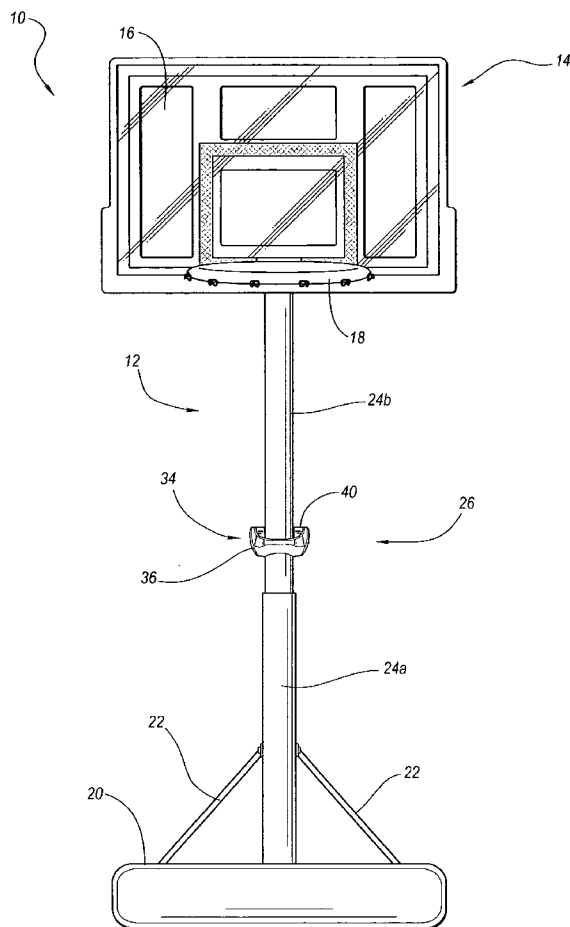

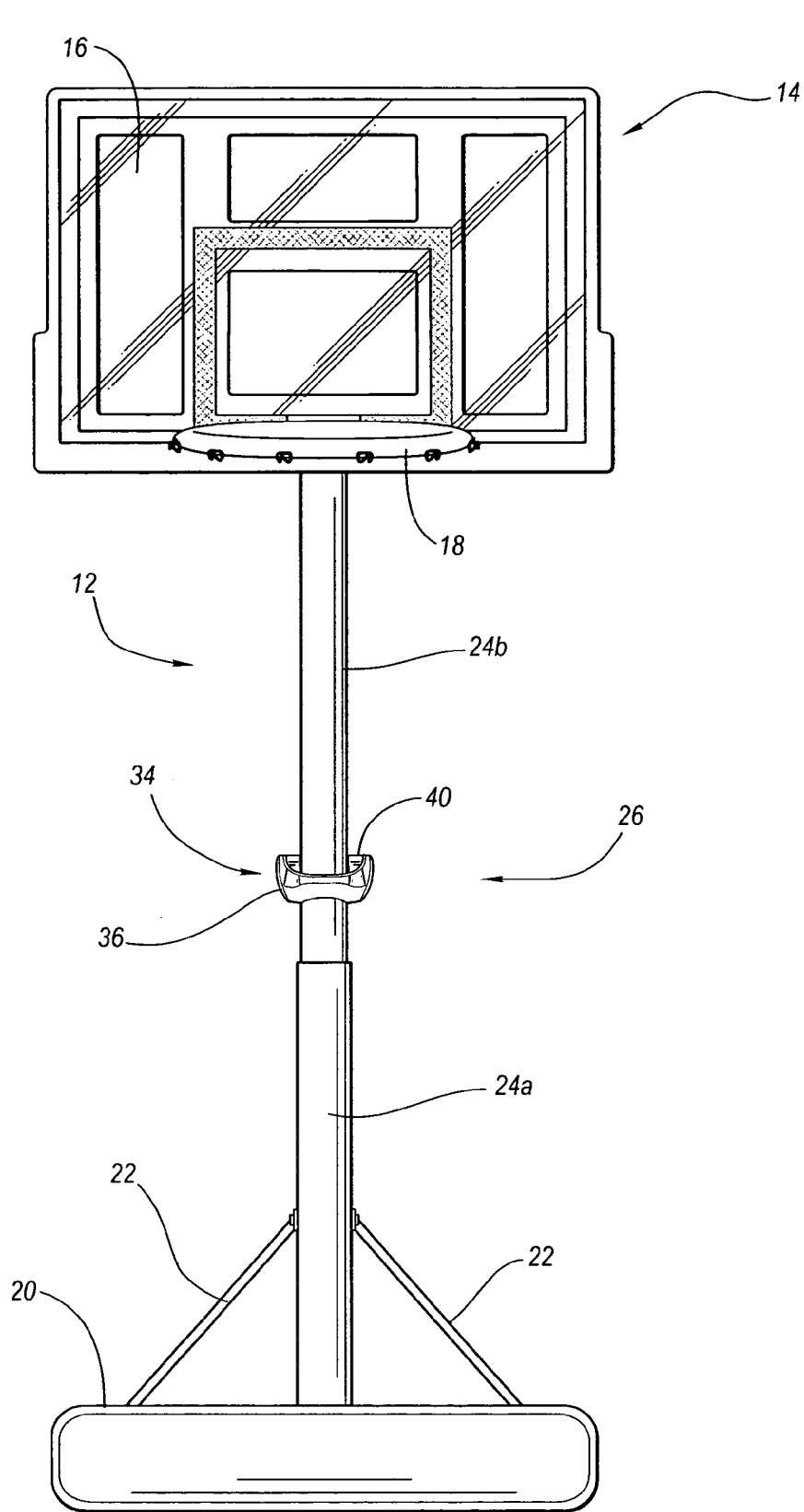
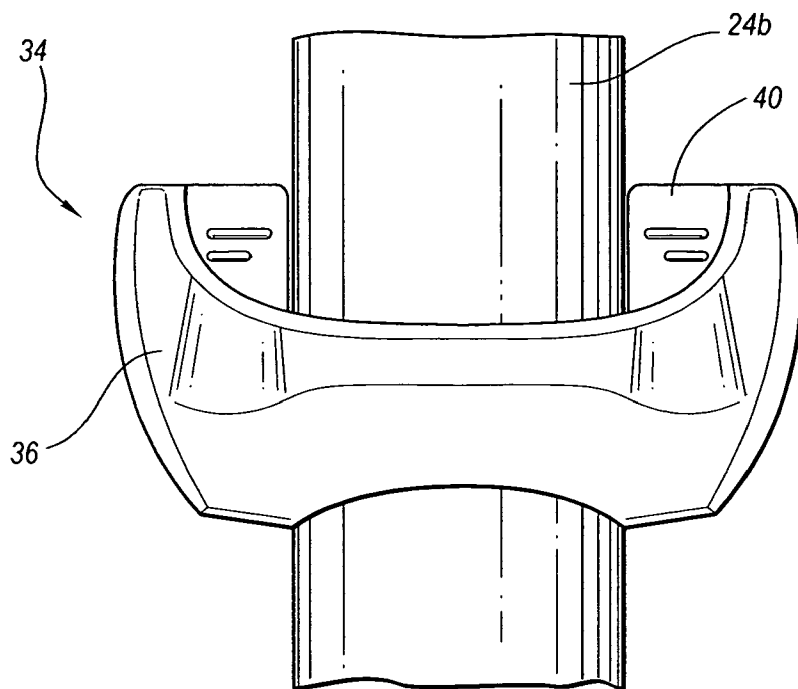
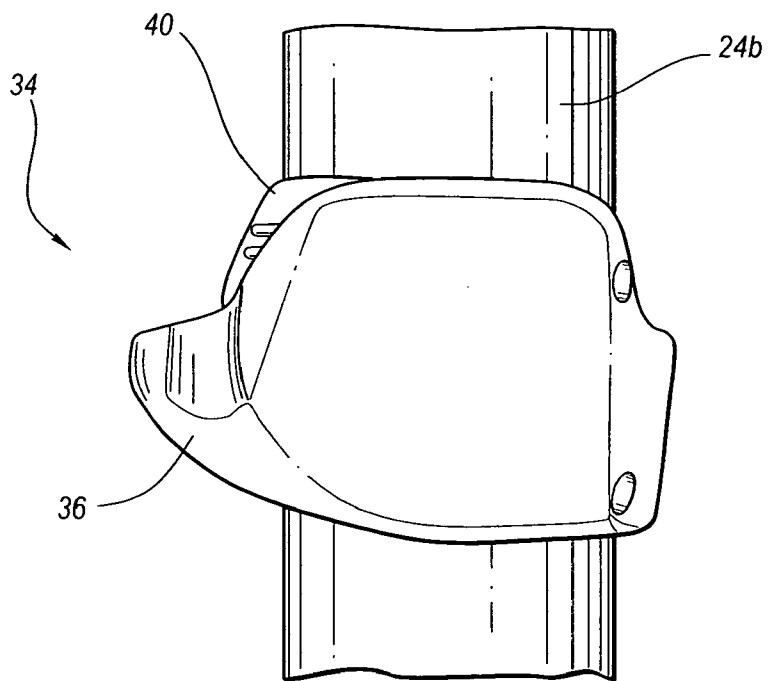

Figure 1



**Figure 2A**



**Figure 2B**

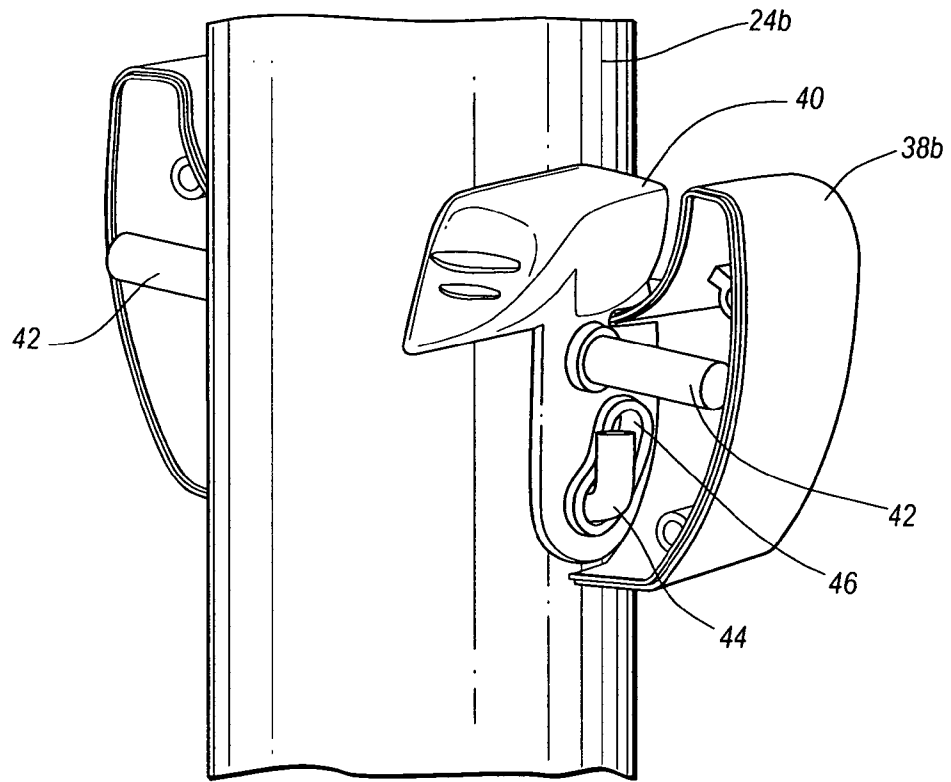

Figure 3

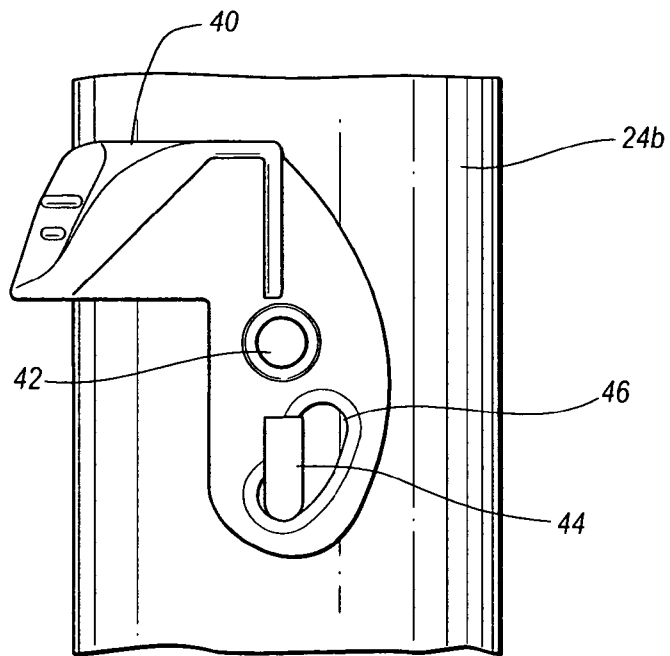

Figure 4

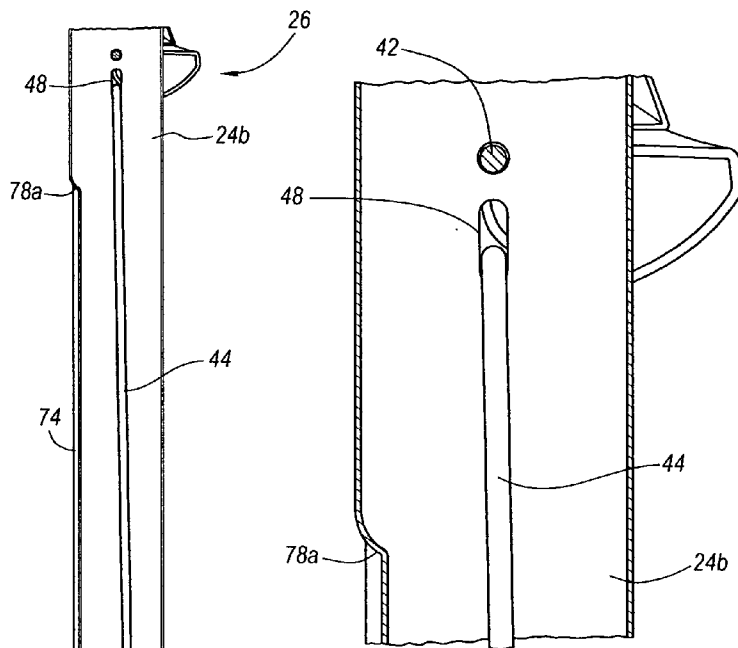

Figure 6

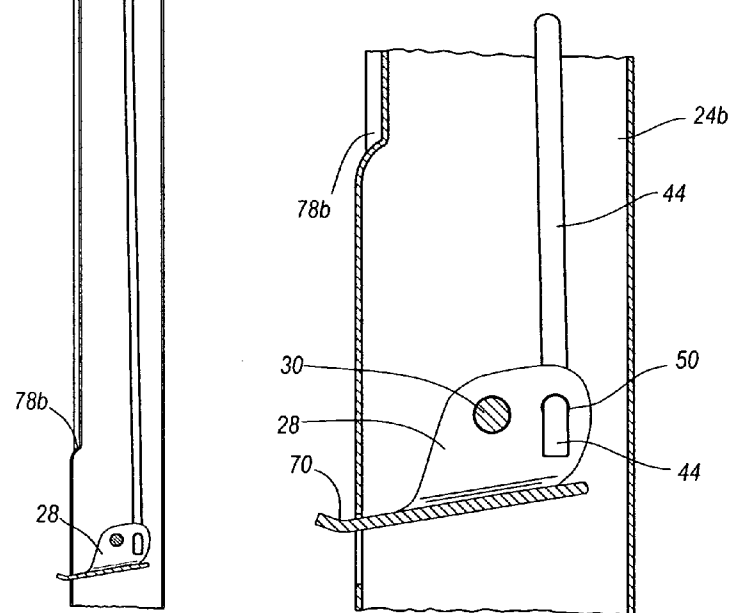

Figure 7

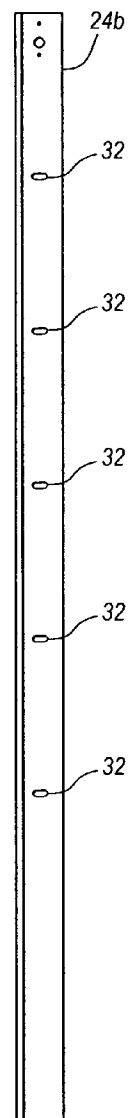

Figure 8

Figure 5

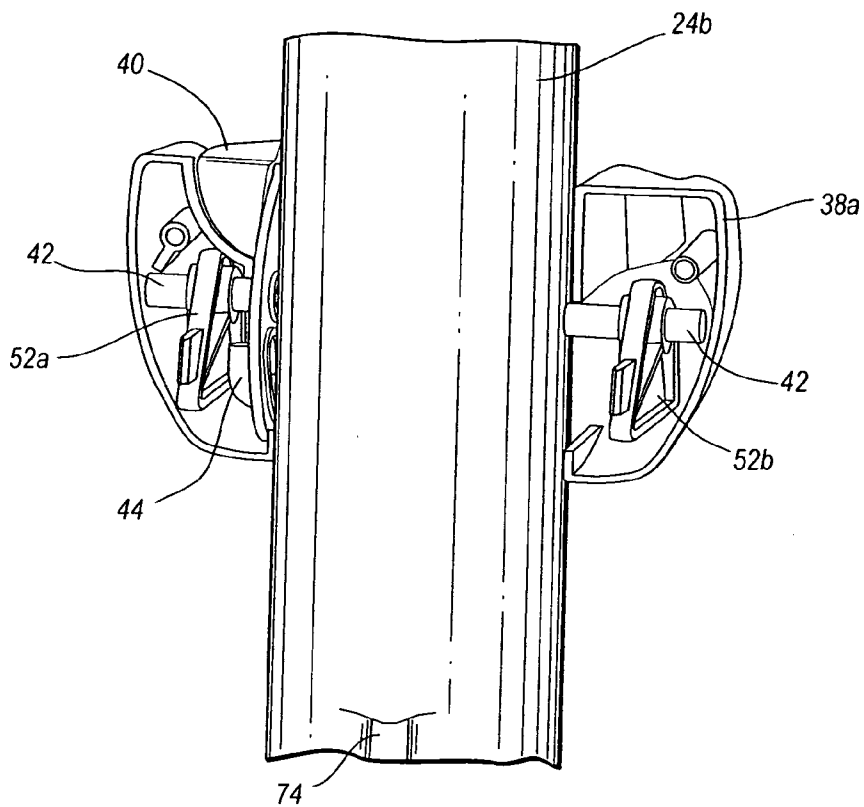

Figure 9

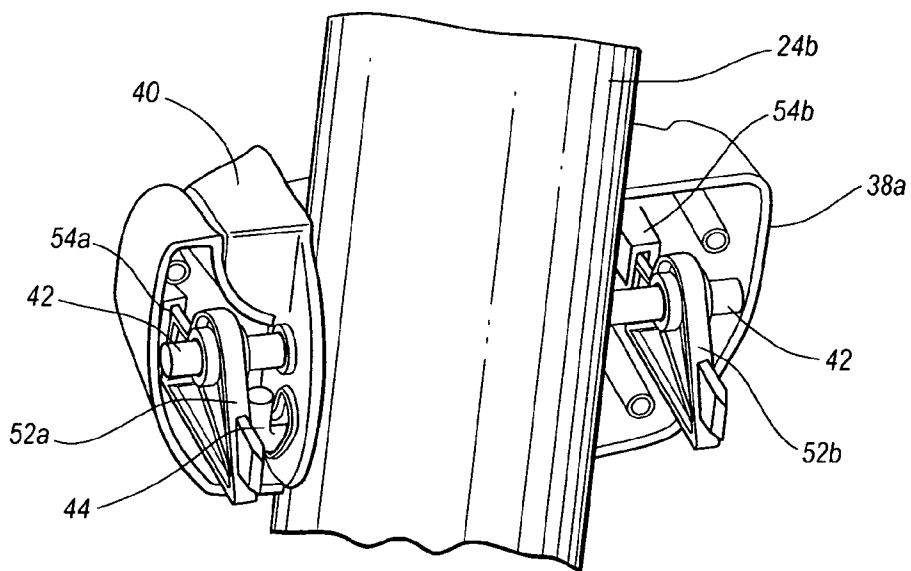

Figure 10

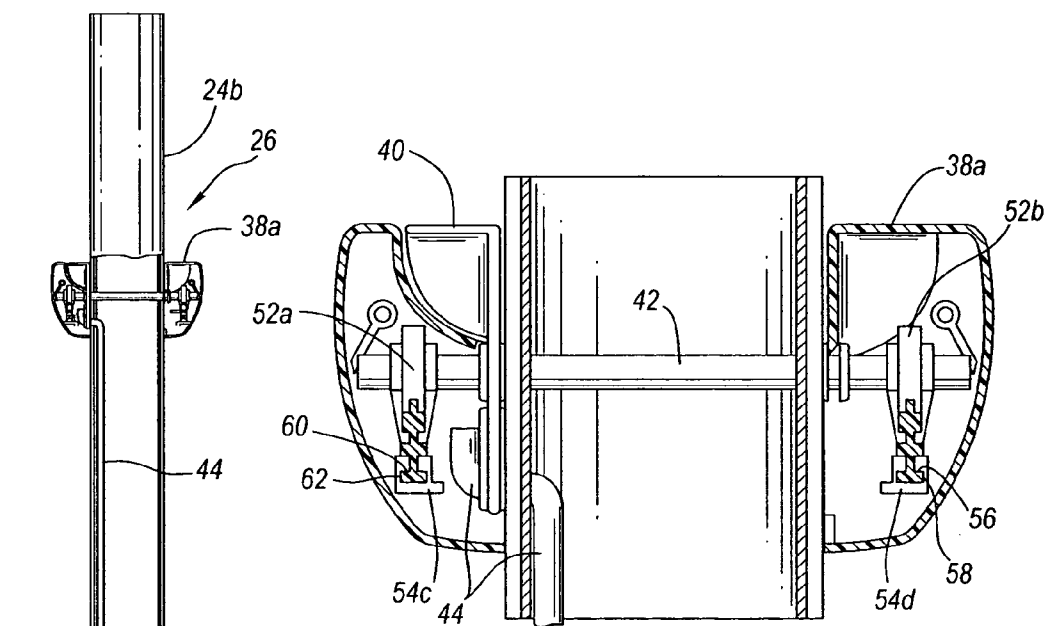

Figure 12

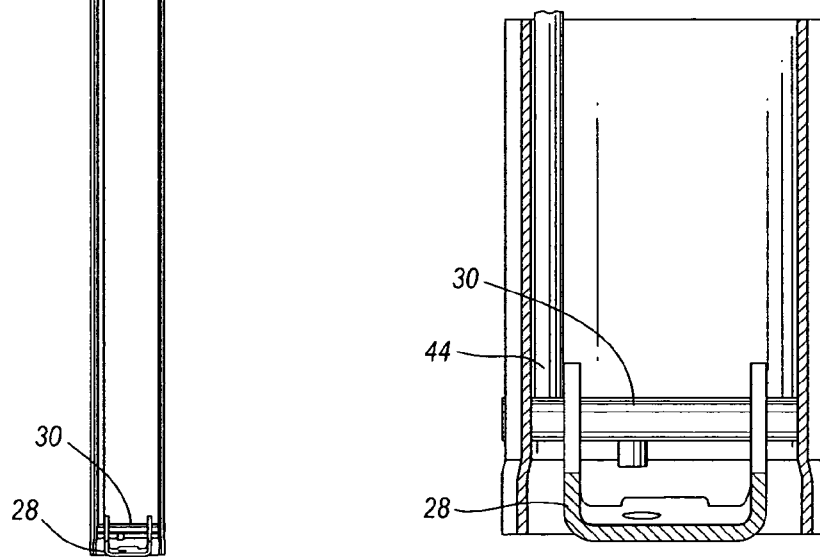

Figure 11

Figure 13

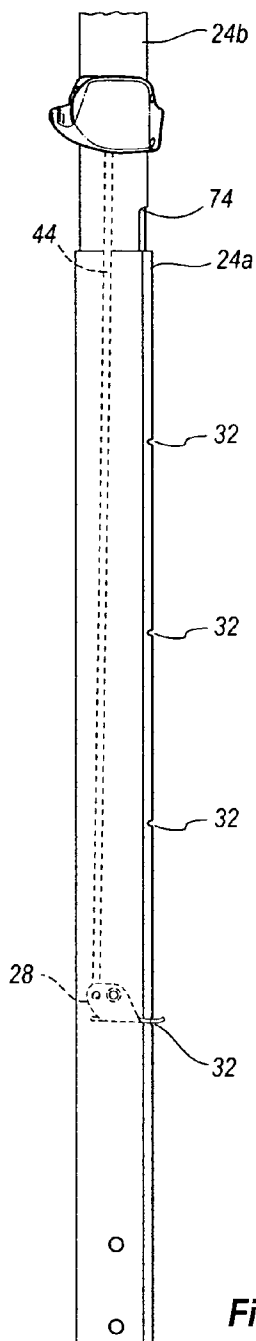

Figure 14

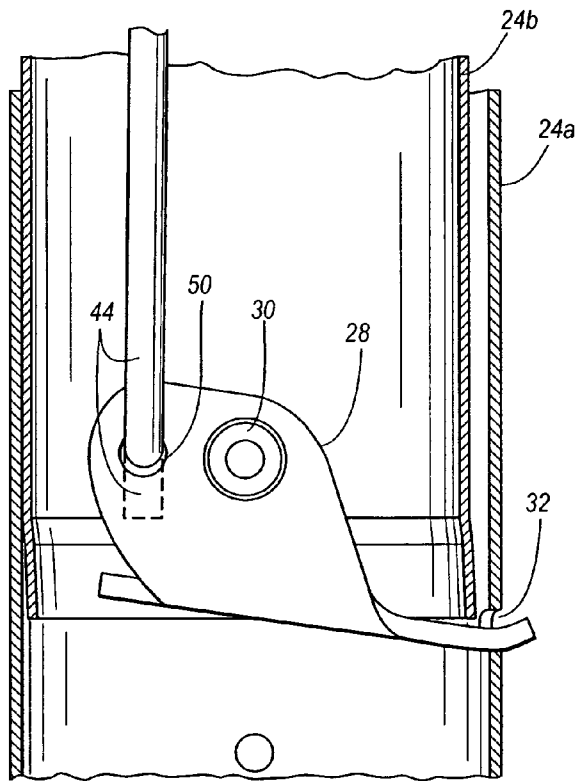

Figure 15



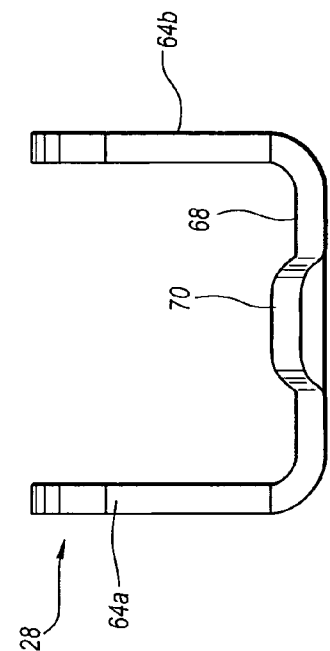

Figure 16

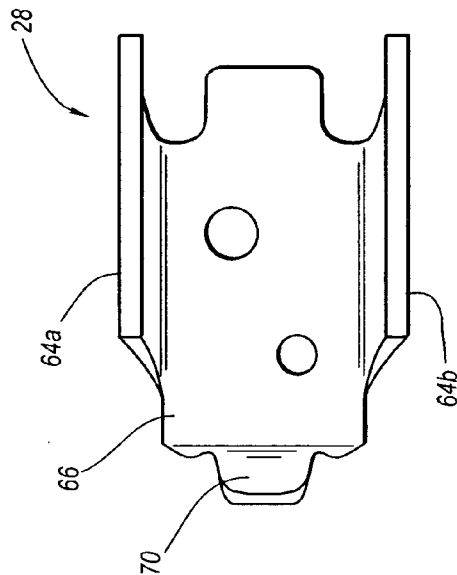

Figure 17

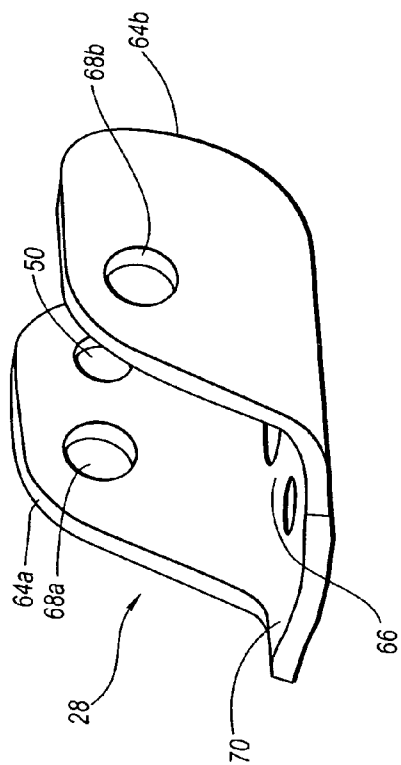

Figure 18

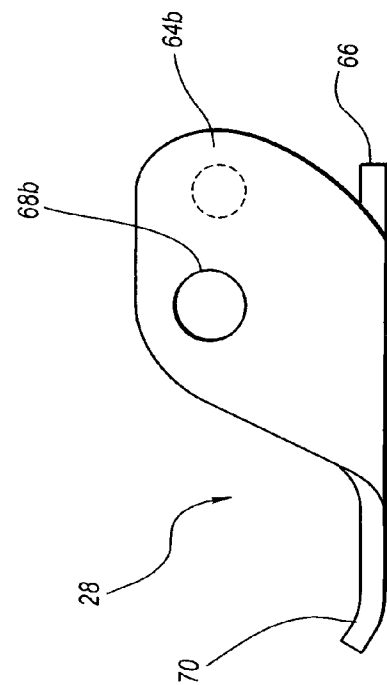

Figure 19

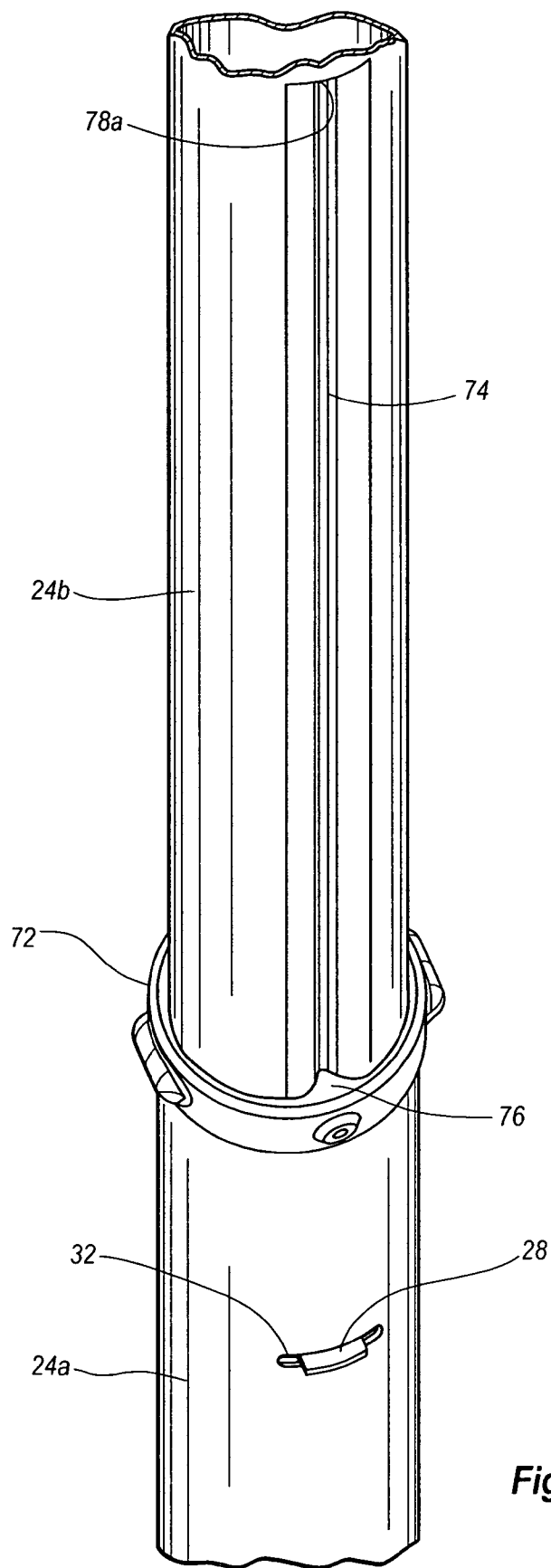

Figure 20

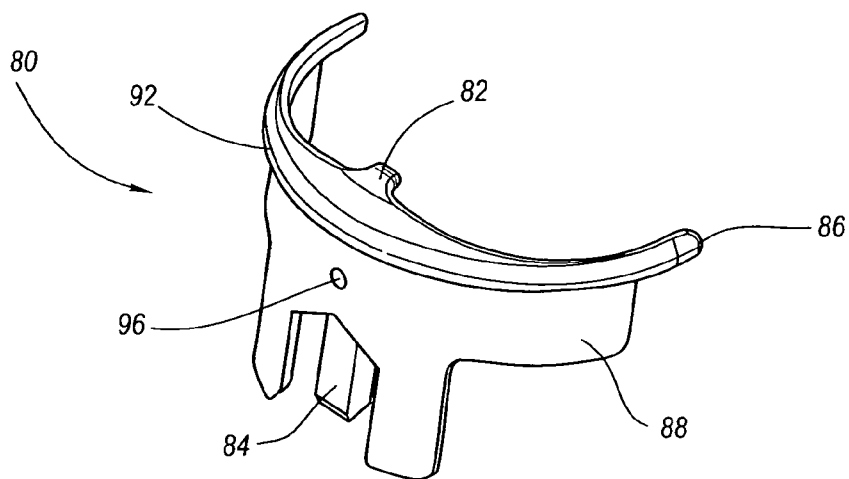

Figure 21

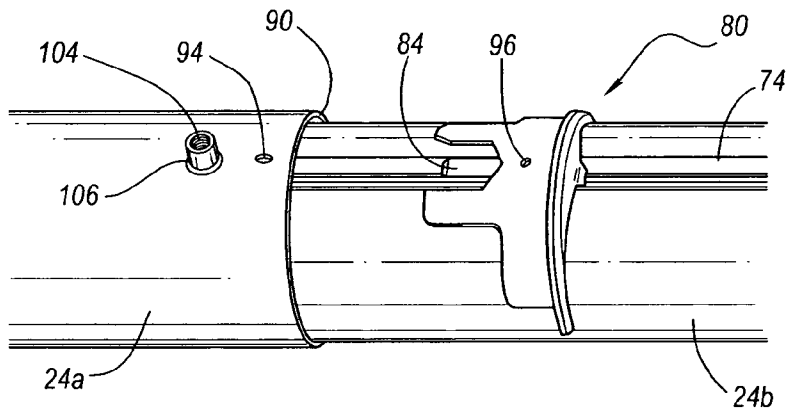

Figure 22

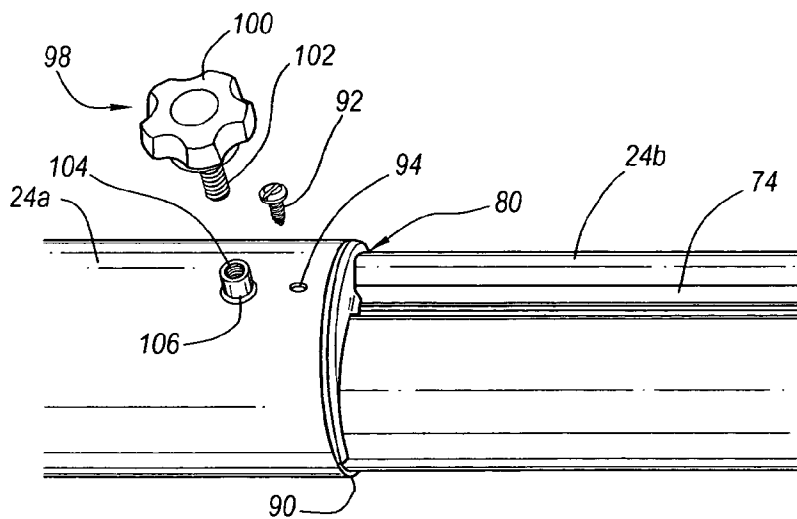

Figure 23

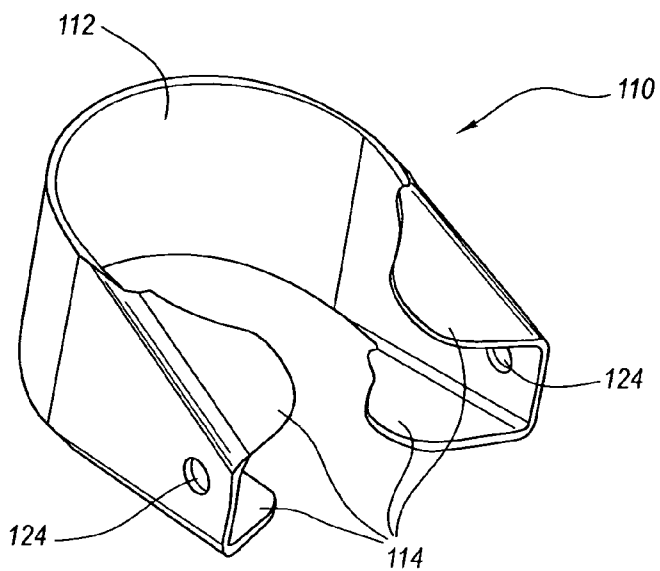

Figure 24

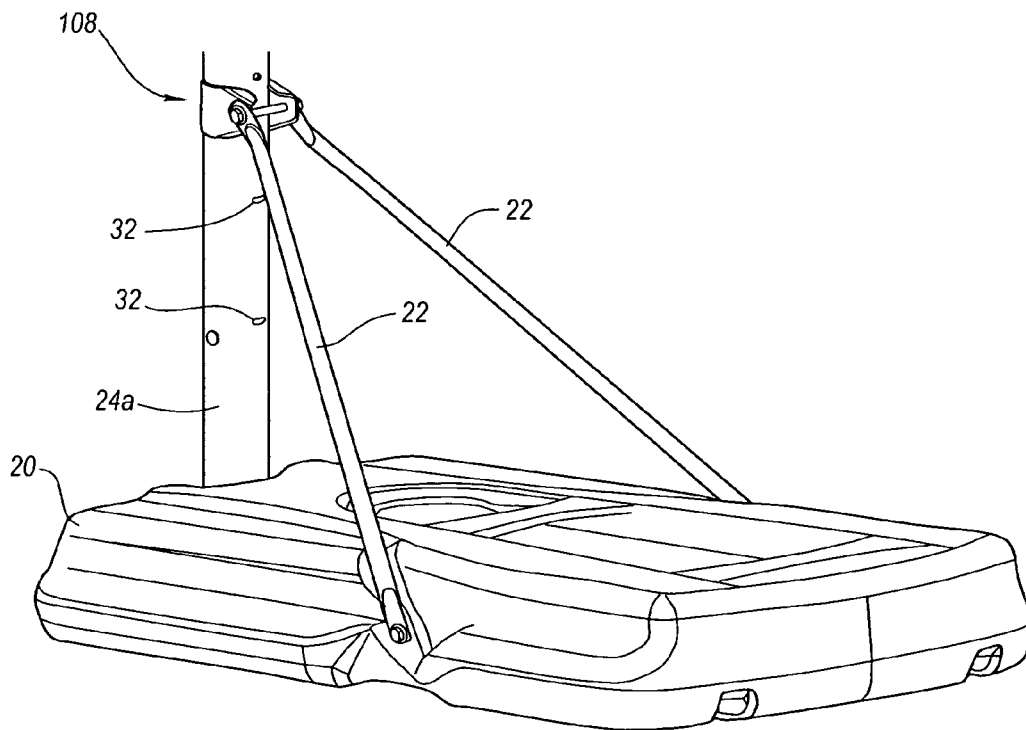

Figure 25

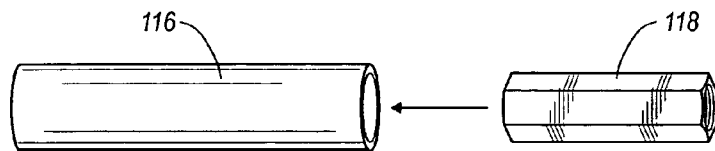

Figure 26

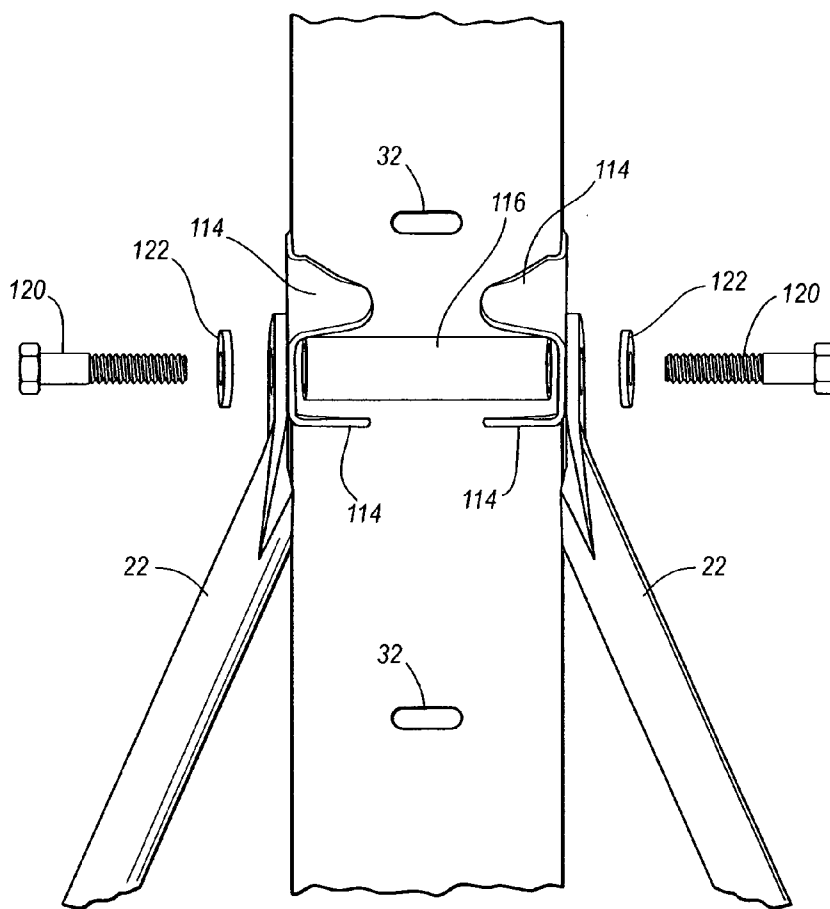

Figure 27

## SUPPORT POLE FOR A BASKETBALL SYSTEM

### CROSS REFERENCE TO RELATED APPLICATIONS

[0001] This application claims priority to and the benefit of U.S. Provisional Patent Application Ser. No. 60/555,528, filed Mar. 22, 2004 and entitled ADJUSTABLE LENGTH BASKETBALL SUPPORT POLE, which is incorporated by reference in its entirety.

### BACKGROUND OF THE INVENTION

[0002] 1. Field of the Invention

[0003] The present invention generally relates to a basketball system and, in particular, to a support pole that may adjust to support a basketball goal at various heights.

[0004] 2. Description of Related Art

[0005] The game of basketball is played by many people throughout the United States and the world. Briefly, the game of basketball typically includes a flat and level playing surface with a basketball goal at each end of the court. The basketball goal, which includes a backboard and a rim or hoop, is typically attached to the top of a support pole. The rim or hoop is normally located ten feet above the playing surface and the backboard is constructed from materials such as wood, plastic or tempered glass.

[0006] Conventional basketball goals often include rigidly mounting the hoop to the basketball backboard so that the face of the backboard is positioned perpendicular to the playing surface and the hoop is positioned parallel to the playing surface. The mounting of the hoop to the backboard must be sufficiently rigid so that the hoop is capable of withstanding various forces and impacts during the game of basketball. For example, the hoop must remain in a generally stationary position so that the basketball rebounds and bounces off the rim in a consistent, dependable manner. In addition, the hoop must be able to withstand various impacts by the players during the game.

[0007] Conventional basketball goals may be permanently mounted by, for example, inserting an end of the support pole into the ground. Conventional basketball goals may also be part of a portable basketball system in which the system may be selectively moved from one location to another.

[0008] In either a portable or a permanently installed basketball system, it may be desirable to adjust the height of the goal above the playing surface. For instance, the basketball system may be used by relatively tall players for some games and by shorter players during other games. The basketball system may also be used at different times by players of different strengths or skill levels. In addition, the basketball system may be used by adults or children. Further, the basketball system may also be used to play a regulation game of basketball or for practicing. In particular, the basketball system may be used to practice dunking the basketball. Accordingly, it is known to adjust the height of the basketball goal above the playing surface so that the basketball system may be used for these different purposes.

[0009] One known approach to adjusting the height of a basketball goal is a support pole with telescoping assembly. In particular, the support pole may include an outer section

and an inner section that is inserted into the outer section. One or more bolts are inserted through openings in the outer section of the support pole to engage the inner section of the support pole. When the bolts are tightened, the bolts engage the inner section of the support pole and the bolts secure the support pole at the desired length. Disadvantageously, the threads on the bolts may be damaged and the bolts may scratch the inner section of pole, particularly where the end of the bolts are forced against the inner section of pole to hold the goal at a particular height. If the inner section of the support pole slips against the bolts, the bolts may create long scratches in the inner section of the support pole. The bolts may also bend, puncture or otherwise the inner section of the support pole.

[0010] Another known approach to adjusting the height of a basketball goal includes a support pole with inner and outer sections that are telescopically connected. One or more retaining pins are inserted through holes in both the inner and outer sections of the telescoping pole. Because the pin extends through the inner section of the support pole rather than engaging the outside surface of the inner section of the pole, the risk of marring or damaging the inner pole is greatly reduced. Once the retaining pins are removed, however, the retaining pins are loose pieces that may easily be lost. In addition, pliers or other tools may be needed to remove or replace the pins. Further, the pins may be very difficult to remove and install.

### BRIEF SUMMARY OF THE INVENTION

[0011] One aspect of the invention is a support pole for a basketball goal system that may be sized and configured to support a basketball backboard and goal above a playing surface. The support pole may be part of a permanent or portable basketball system.

[0012] Another aspect is a support pole for a basketball system that may be adjustable in length. For example, a conventional basketball goal is typically located ten feet above the playing surface, but that height may make it very difficult for children and others to play basketball. The adjustable length support pole, which allows the height of the basketball goal to be raised or lowered, may allow children and others to play basketball. Preferably, the support pole is telescopically adjustable to allow the height of the basketball goal to be adjusted.

[0013] Yet another aspect is a support pole for a basketball system that may include a support pole with an inner section and an outer section. The inner section of the support pole may be telescopically connected to the outer section and an adjustment assembly may allow the length of the support pole to be adjusted. In particular, the adjustment assembly may be sized and configured to normally hold the inner and outer sections of the support pole in a fixed position so that basketball can be played. The adjustment assembly may also allow the inner section and outer sections to move relative to each other to allow the length of the support pole to be adjusted. This may allow the height of the basketball goal to be raised or lowered.

[0014] Still another aspect is a support pole for a basketball system that may include at least one support pole section which is adjustable length. The adjustable length support pole section may allow the height of the basketball goal to be raised or lowered to a desired height.

[0015] A further aspect is a support pole for a basketball system that may include an adjustment assembly which allows the length of the support pole and/or a section of the support pole to be adjusted. The adjustment assembly, for example, may include one or more surfaces or components that frictionally abut or contact the support pole. In particular, the adjustment assembly may include one or more surfaces that frictionally engage or contact an inner section of the support pole to secure the inner section of the support pole in a generally fixed position relative to an outer section of the support pole. The adjustment assembly may also include one or more surfaces or components that engage or are inserted into one or more openings or apertures. For example, the adjustment assembly may include one or more locking members that are selectively inserted through openings, apertures or depressions to secure the support pole at a desired length and/or secure the at least one support pole section at a desired height.

[0016] Still another aspect is a support pole for a basketball system that may include an adjustment assembly with an adjustment mechanism which is sized and configured to allow the height of the basketball goal to be adjusted. For example, the adjustment mechanism may include a handle that can be turned to selectively adjust the length of the support pole and/or the height of at least one support pole section. Also, the adjustment mechanism may include a trigger that can be used to selectively adjust the length of the support pole and/or the height of at least one support pole section. Desirably, the handle and/or the trigger are positioned such that may selectively adjust the length of the support pole and/or the height of at least one support pole section.

[0017] Another aspect is a support pole for a basketball system that may be part of a portable basketball system. The portable basketball system may include, for example, a ballast-receiving base that is attached to an end portion of the support pole. The base may rest on a support surface such as a floor, driveway, or other suitable surface, and it may support the pole.

[0018] A further aspect is a support pole for a basketball system that may be adjustable in height. For example, the support pole may include a telescoping assembly with an inner section and an outer section. The inner section of the support pole may be movable among a plurality of predetermined positions by telescoping movement within the outer section of the support pole. Desirably, the support pole is adjustable in length in the range from about seven-and-one-half feet to about ten feet. Thus, a wide variety of players may use the basketball system. Of course, the support pole may be adjustable to any other suitable lengths, if desired.

[0019] Advantageously, the support pole and the height adjustment assembly may have a pleasing appearance or design. In addition, the support pole and the height adjustment assembly may have few moving parts and these components may be easily manufactured. The support pole and the height adjustment assembly may also have a relatively straight-forward design and these components may be used in connection with any suitable type of basketball system. The support pole and the height adjustment assembly may also be cost effective because they may require few components that can be easily assembled. Further, the height

adjustment assembly may securely and easily allow the length of the support pole to be adjusted, and the adjustment assembly may be relatively lightweight. Desirably, a single person may operate the height adjustment assembly and the user may use one or two hands to operate the assembly. It will be appreciated that more than one person may also operate the height adjustment assembly, if desired.

[0020] These and other aspects, features and advantages of the present invention will become more fully apparent from the following detailed description of preferred embodiments and appended claims.

#### BRIEF DESCRIPTION OF THE DRAWINGS

[0021] The appended drawings contain figures of preferred embodiments to further clarify the above and other aspects, advantages and features of the present invention. It will be appreciated that these drawings depict only preferred embodiments of the invention and are not intended to limit its scope. The invention will be described and explained with additional specificity and detail through the use of the accompanying drawings in which:

[0022] FIG. 1 is a front view of an exemplary embodiment of a basketball system;

[0023] FIG. 2A is an enlarged front view of a portion of the basketball system shown in FIG. 1, illustrating an exemplary embodiment of an adjustment mechanism;

[0024] FIG. 2B is a side view of the adjustment mechanism shown in FIG. 2A;

[0025] FIG. 3 is a perspective view of the adjustment mechanism shown in FIG. 2A, with a portion of the adjustment mechanism cut-away;

[0026] FIG. 4 is a side view of a portion of the adjustment mechanism shown in FIG. 2A;

[0027] FIG. 5 is a cross-sectional, left side view of a portion of an exemplary embodiment of an adjustment assembly including the adjustment mechanism shown in FIG. 2A;

[0028] FIG. 6 is an enlarged cross-sectional, left side view of an upper portion of the adjustment assembly shown in FIG. 5;

[0029] FIG. 7 is another enlarged cross-sectional, left side view of a lower portion of the adjustment assembly shown in FIG. 5;

[0030] FIG. 8 is a rear view of a portion of the basketball system shown in FIG. 1, illustrating an exemplary embodiment of a support pole section;

[0031] FIG. 9 is another perspective view of components of the adjustment mechanism shown in FIG. 2A;

[0032] FIG. 10 is yet another perspective view of components of the adjustment mechanism shown in FIG. 2A;

[0033] FIG. 11 is a partial cross-sectional, rear view of a portion of the basketball system shown in FIG. 1, illustrating the adjustment assembly shown in FIG. 5;

[0034] FIG. 12 is an enlarged cross-sectional, rear view of a portion of an upper portion of the adjustment assembly shown in FIG. 11;

[0035] FIG. 13 is an enlarged cross-sectional, rear view of a portion of a lower portion of the adjustment assembly shown in FIG. 11;

[0036] FIG. 14 is a right side view of a portion of the basketball system, illustrating the adjustment assembly shown in FIG. 5 securing an exemplary embodiment of a pair of support pole sections;

[0037] FIG. 15 is a right cross-sectional side view of a portion of the adjustment assembly and support pole sections shown in FIG. 14;

[0038] FIG. 16 is a perspective view of an exemplary embodiment of a locking member that may be used in connection with an adjustment assembly;

[0039] FIG. 17 is a right side view of the locking member shown in FIG. 16;

[0040] FIG. 18 is a front view of the locking member shown in FIG. 16;

[0041] FIG. 19 is a top view of the locking member shown in FIG. 16;

[0042] FIG. 20 a perspective view a portion of the basketball system illustrating an exemplary embodiment of alignment members;

[0043] FIG. 21 is an enlarged perspective view of a portion of the alignment members shown in FIG. 20;

[0044] FIG. 22 is a side view of a portion of the alignment members shown in FIG. 20;

[0045] FIG. 23 is an exploded side view of a portion of the alignment members shown in FIG. 20;

[0046] FIG. 24 is an enlarged perspective view of a bracket that may be used in connection with a portable basketball system;

[0047] FIG. 25 is a perspective view of a portion of a portable basketball system that may be used in connection with the bracket shown in FIG. 24;

[0048] FIG. 26 is an exploded view of a portion of the portable basketball system shown in FIG. 25; and

[0049] FIG. 27 is another exploded view of a portion of the portable basketball system shown in FIG. 25.

#### DETAILED DESCRIPTION OF THE PREFERRED EMBODIMENTS

[0050] The present invention is generally directed towards a support pole for a basketball system. The support pole may be adjustable to allow a basketball goal to be supported at various heights. The principles of the present invention, however, are not limited to support poles for basketball systems that are adjustable in height. It will be understood that, in light of the present disclosure, the support pole disclosed herein can be successfully used in connection with other types of sports, activities, or structures.

[0051] Additionally, to assist in the description of the support pole, words such as top, bottom, front, rear, right and left may be used to describe the accompanying figures. It will be appreciated, however, that the present invention can be located in a variety of desired positions—including

various angles, sideways and even upside down. A detailed description of the support pole now follows.

[0052] As shown in FIG. 1, an exemplary embodiment of a basketball system 10 includes a support pole 12. The support pole 12 is preferably sized and configured to maintain a basketball goal 14 above a playing surface. The basketball goal 14 preferably includes a basketball backboard 16, a basketball rim 18, and may also include a net (not shown). The basketball system 10 is preferably configured as a portable basketball goal system, which may include a base 20 that is preferably constructed of blow-molded plastic and may include a generally hollow interior portion that is sized and configured to receive ballast, such as sand or water. The basketball systems may include a plurality of braces 22 that connect the base 20 and the support pole 12 to help secure the support pole in a desired position. Also, one or more wheels may be coupled to the base 20 to help move the basketball system 10 to a desired location. Other aspects of exemplary embodiments of portable basketball systems that may be used in connection with the basketball system 10 are disclosed in U.S. Pat. No. 6,432,003, filed Aug. 14, 2000, entitled ADJUSTABLE WHEEL ENGAGEMENT ASSEMBLY FOR BASKETBALL GOAL SYSTEMS; U.S. Pat. No. 6,656,065, filed Jan. 16, 2002, entitled WHEEL MOUNTED ADJUSTABLE ROLLER SUPPORT ASSEMBLY FOR A BASKETBALL GOAL SYSTEM, which are incorporated by reference in their entireties. It will be appreciated that the support pole 12 may be sized and configured to be part of a portable basketball system, a permanent basketball system, or other sporting systems.

[0053] As shown in FIG. 1, the support pole 12 is advantageously sized and configured to adjust the height of the basketball goal 14. For example, a conventional basketball goal is normally located ten feet above the playing surface, but that height may make it very difficult for children and others to play basketball. The support pole 12 may have an adjustable length that allows the height of the basketball goal 14 to be raised or lowered, thus permitting children and others to play basketball.

[0054] To adjust the height of the basketball goal 14, the support pole 12 may include one or more sections that are preferably telescopically, slidably and/or otherwise movably connected. For example, the support pole 12 may include a first support pole section 24a and a second support pole section 24b. The support pole sections 24 are preferably sized and configured to telescope, slide and/or otherwise move between a first position in which the support pole 12 has a first length and a second position in which the support pole 12 has a second length. Thus, the support pole sections 24 are preferably sized and configured to move between a first position in which the basketball goal 14 is supported in a generally fixed position at a first height and a second position in which the basketball goal is supported in a generally fixed position at a second, different height.

[0055] To telescopically connect the support pole sections, at least a portion of the support pole section 24b may nest within the support pole section 24a as shown, for example, in FIG. 1. Also, to telescopically connect the support pole sections, the support pole section 24a may nest within the support pole section 24b, if desired. Advantageously, the telescopically connected support pole sections 24 may move



among a variety of positions to support the basketball goal **14** at a variety of heights. It will be appreciated that the support pole **12** does not require telescopically connected support pole sections **24**, and the support pole may comprise any suitable number of one or more support pole sections that may be connected in other suitable fashions.

[0056] The support pole **12** may also include a support pole section **24b** that is coupled to a mounting member, which supports the support pole section **24b** in a desired position. For example, the support pole section **24b** may be coupled to a mounting member such as the support pole section **24a**, the base **20** or other suitable structure. At least a portion of the support pole section **24b** preferably nests with the mounting member to telescopically, slidably and/or otherwise movably connect the mounting member and the support pole **12**. Advantageously, the support pole section **24b** may move between a first position in which the basketball goal **14** is at a first height and a second position in which the basketball goal is at a second, different height.

[0057] The support pole **12** and/or the support pole sections **24** are preferably constructed of a strong, durable material such as steel, aluminum or other metal, and preferably have a generally cylindrical, tubular configuration. It will be appreciated, however, that the support pole **12** and/or the support pole sections **24** may be constructed from other materials with suitable characteristics. Further, the support pole **12** and/or the support pole sections **24** may have other suitable shapes and/or configurations, such as a generally square or rectangular cross-section.

[0058] As best seen in FIGS. 1, 2A, 2B, 3, 5, and 11, the basketball system **10** may include an adjustment assembly **26** that is preferably sized and configured to releasably and/or selectively secure the basketball goal **14** at a plurality of heights. For example, the height of the basketball goal **14** may be adjusted by adjusting the length of the support pole **12**, and the adjustment assembly **26** is preferably sized and configured to releasably and/or selectively secure the support pole **12** at various lengths. In particular, the adjustment assembly **26** may be sized and configured to releasably and/or selectively secure the support pole **12** in one or more positions, such as a first position in which the support pole has a first length and a second position in which the support pole has a second length. To releasably and/or selectively secure the support pole **12** in a desired position, at least a portion of the adjustment assembly **26** may move between a first position in which the adjustment assembly secures the support pole sections **24** in a generally fixed position and a second position in which the support pole sections may move to adjust the length of the support pole **12**.

[0059] As another example, the height of the basketball goal **14** may be adjusted by adjusting the height of the support pole section **24b**, and the adjustment assembly **26** is preferably sized and configured to releasably and/or selectively secure the support pole section **24b** at various heights. For example, the adjustment assembly **26** may be sized and configured to releasably and/or selectively secure the support pole section **24b** in one or more positions, such as a first position in which the basketball goal **14** is at a first height and a second position in which the basketball goal is at a second height. To releasably and/or selectively secure the support pole section **24b** at a desired height, at least a portion of the adjustment assembly **26** may move between a first

position in which the adjustment assembly secures the support pole section **24b** in a generally fixed position and a second position in which the support pole section **24b** may move to a desired height.

[0060] The adjustment assembly **26**, for example, may include one or more surfaces or components that frictionally abut or contact the support pole **12**. In particular, the adjustment assembly **26** may include one or more surfaces that frictionally engage or contact the support pole section **24b** to secure the support pole section **24b** in a generally fixed position relative to the support pole section **24a**. The adjustment assembly **26** may also include one or more surfaces or components that engage or are inserted into one or more openings or apertures. For example, the adjustment assembly **26** may include one or more locking members **28** that are selectively inserted through openings, apertures or depressions to secure the support pole **12** at a desired length and/or secure the support pole section **24b** at a desired height.

[0061] As best seen in FIGS. 5, 7, 11, 13-19, the adjustment assembly may include a locking member **28** that is preferably sized and configured to releasably and/or selectively secure the basketball goal **14** at various heights. For example, the locking member **28** may be sized and configured to releasably and/or selectively secure the support pole **12** in one or more positions, such as a first position in which the support pole has a first length and a second position in which the support pole has a second length. To releasably and/or selectively secure the support pole **12** in a desired position, at least a portion of the locking member **28** may move between a first position in which the locking member secures the support pole sections **24** in a generally fixed position and a second position in which the support pole sections may move to adjust the length of the support pole **12**. To allow the locking member **28** to pivot or otherwise move among a plurality of positions, the locking member **28** is preferably connected to the support pole section **24b** by a connecting member such as a pin **30**. One of ordinary skill in the art will appreciate that the pin **30** may consist of one or more pins, rods, rivets, bolts, screws, fasteners, or other suitable structures. It will be appreciated that the locking member **28** need not be connected to the support pole section **24b**.

[0062] As another example, the locking member **28** may be sized and configured to releasably and/or selectively secure the support pole section **24b** in one or more positions, such as a first position in which the basketball goal **14** is at a first height and a second position in which the basketball goal is at a second height. To releasably and/or selectively secure the support pole section **24b** at a desired height, at least a portion of the locking member **28** may move between a first position in which the locking member secures the support pole section **24b** in a generally fixed position and a second position in which the support pole section **24b** may move to a desired height.

[0063] In greater detail, to releasably and/or selectively secure the support pole **12** or the support pole sections **24** in a desired position or height, the locking member **28** preferably may pivot or otherwise move between a locked position and an unlocked position. As shown in FIGS. 5, 7, 8, 14, and 15, in the locked position, at least a portion of the locking member **28** may advance beyond an outer surface of the

support pole section **24b**, advance into or through a locking member receiving portion **32**, and/or advance beyond an outer surface of the support pole section **24a**. Thus, in the locked position, at least a portion of the locking member **28** may engage at least a portion of the support pole section **24a** and secure the support pole sections **24** in a generally fixed position—which may secure the basketball goal **14** at a generally fixed height. In the unlocked position, the locking member **28** may be retracted within an outer surface of the support pole section **24a**, retracted from a locking member receiving portion **32**, and/or retracted within an outer surface of the support pole section **24b**. Thus, in the unlocked position, the locking member **28** may allow the support pole sections to move to adjust the length of the support pole **12** and/or the height of the support pole section **24b**—which may allow one to adjust the height of the basketball goal **14**.

[0064] As shown in FIG. 8, to further help secure the basketball goal **14** at different heights, the support pole section **24a** preferably includes one or more locking member receiving portions **32** that are sized and configured to receive and/or retain at least a portion of the locking member **28** in the locked position. The locking member receiving portions **32** may include one or more recessed portions, apertures, openings, grooves, channels and the like. The locking member receiving portions **32** preferably have a generally oblong configuration. The generally oblong locking member receiving portions **32** may have a pair of opposing generally linear sides extending between a pair of opposing generally curvilinear ends. The generally oblong locking member receiving portions **32** may also have a generally rectangular configuration, which may further include rounded corners. Additionally, the generally oblong locking member receiving portions **32** may have a generally oval or elliptical configuration. The generally oblong locking member receiving portions **32** may help apply forces along a greater distance, which may help avoid more concentrated stresses applied against the support pole section **24a** and/or against the locking member. As shown in FIG. 8, the locking member receiving portions **32** are preferably spaced apart at least a substantial distance from each other to help secure the basketball goal **14** at a variety of different heights. It will be appreciated that the locking member receiving portions **32** may be spaced at any suitable relative distances, depending, for example, upon a desired adjustable height range for the basketball goal. Further, it will be appreciated that the locking member receiving portions may have other suitable shapes and/or configurations (including but not limited to circular, square, polygonal, irregular and the like) depending, for example, the particular shape and/or configuration of the locking member **28**. Also, the locking member receiving portions **32** may include, for example, detents or the like.

[0065] As best seen in FIGS. 1, 2A, and 2B, the adjustment assembly **26** preferably includes an adjustment mechanism **34**, which is preferably sized and configured to releasably and/or selectively secure the basketball goal **14** at a plurality of heights. In greater detail, the adjustment mechanism **34** is preferably sized and configured to manipulate the position of the locking member **28**. By manipulating the locking member **28**, the adjustment mechanism **34** may releasably and/or selectively secure the support pole **12** at various lengths and/or the support pole section **24b** at various heights.

[0066] The adjustment mechanism **34** preferably includes a handle **36**, which a person may grasp when adjusting the height of the basketball goal **14**. As shown in FIGS. 3 and 9-12, the handle **36** may include one or more handle sections, such as handle sections **38a**, **38b**, which may be connected using one or more fasteners. For example, the handle sections **38** may include one or more fastener bosses that are sized and configured to receive and/or retain at least a portion of fastener, such as a screw or a bolt. The handle sections **38** may be also be connected using a snap fit, a friction fit, and/or an interference fit. It will be appreciated that the handle **36** may include a plurality of interconnected handle sections **38**, but the handle may have a unitary, one-piece construction. Further, the handle **36** may include one or more knobs, grips and the like.

[0067] In one embodiment, the handle **36** preferably may be turned or otherwise moved to manipulate the position of the locking member **28**. By manipulating the locking member **28**, the handle **36** may releasably and/or selectively secure the support pole **12** at various lengths and/or the support pole section **24b** at various heights, which may releasably and/or selectively securing the basketball goal **14** at a plurality of heights.

[0068] As best seen in FIGS. 1, 2A, 2B, 3, 4, 9, 10, and 12, the adjustment mechanism **34** preferably includes a trigger **40**, which is preferably sized and configured to be operated by a thumb or finger of the user. The trigger **40** is preferably sized and configured to manipulate the position of the locking member **28**. By manipulating the locking member **28**, the trigger **40** may releasably and/or selectively secure the support pole **12** at various lengths and/or the support pole section **24b** at various heights, which may releasably and/or selectively securing the basketball goal **14** at a plurality of heights. For example, to releasably and/or selectively secure the support pole **12** in a desired position, the trigger **40** may move between a first, locked position in which the locking member secures the support pole sections **24** in a generally fixed position and a second, unlocked position in which the support pole sections may move to adjust the length of the support pole **12**. As another example, to releasably and/or selectively secure the support pole section **24b** at a desired height, the trigger **40** may move between a first, locked position in which the locking member **28** the support pole section **24b** in a generally fixed position and a second, unlocked position in which the support pole section **24b** may move to a desired height. As best seen in FIGS. 3-4 and 9-10, to allow the trigger **40** to pivot or otherwise move among a plurality of positions, the trigger **40** is preferably connected to the support pole section **24b** using a connector **42** such as one or more pins, rods, rivets, bolts, screws, fasteners or other suitable structures.

[0069] As best seen in FIGS. 3, 4, 5-7, 9-15, the adjustment assembly **26** may include a connecting member **44** that is sized and configured to connect the adjustment mechanism **34** and the locking member **28**. The trigger **40**, the support pole section **24b** and/or the locking member **28** may be sized and configured to be connected to the connecting member **44**. For example, as best seen in FIGS. 3, 4 and 6, the trigger **40** preferably includes a connecting member receiving portion **46** and the support pole section **24b** preferably includes a connecting member receiving portion **48**. The connecting member receiving portions **46**, **48** are preferably elongated apertures or slots, at least a portion of

which are offset and at least a portion of which intersect. The connecting member receiving portion **46** of the trigger **40** preferably has a generally curvilinear, J-shaped configuration and the connecting member receiving portion **48** of the support pole section **24b** preferably has a generally linear configuration. As best seen in **FIGS. 7 and 15-16**, the locking member **28** may also include a connecting member receiving portion **50**, which preferably comprises an aperture that is sized and configured to receive at least a portion of the connecting member **44**. Of course, the connecting member receiving portions **46**, **48** and **50** may have other suitable shapes and configurations, depending upon the particular configuration of the connecting member.

[0070] As best seen in **FIGS. 3, 4 and 6**, the connecting member **44** is at least partially disposed within each of the connecting member receiving portions **46**, **48** and **50**, which allows the connecting member receiving portions to move the connecting member **44** that moves the locking member. Specifically, as the trigger **40** is depressed, the connecting member **44** moves along the connecting member receiving portions **46** and **48** from a first, locked position to a second, unlocked position. As the connecting member **44** moves along the connecting member receiving portions **46** and **48**, the connecting member **44** pivots the locking member **28** from the locked position to the unlocked position. A person may then adjust the height of the basketball goal **14** as desired. Similarly, as the trigger **40** is released, the connecting member **44** moves along the connecting member receiving portions **46** and **48** from the second, unlocked position to the first, locked position. As the connecting member **44** moves along the connecting member receiving portions **46** and **48**, the connecting member **44** pivots the locking member **28** from the unlocked position to the locked position. Thus, the basketball goal **14** is secured at the desired height.

[0071] It will be appreciated that the connecting member **44**, the trigger **40** and/or the locking member **28** may be sized and configured to allow gravity to apply a force to move the locking member **28** from the unlocked position toward the locked position and/or to move the trigger **40** from the unlocked position toward the locked position. It will also be appreciated that a biasing member, such as a spring, may be sized and configured to bias the locking member **28** from the unlocked position toward the locked position and/or to bias the trigger **40** from the unlocked position toward the locked position.

[0072] As best seen in **FIGS. 9-12**, the handle sections **38** may be connected to the support pole section **24b** using the pin **42** and handle support members **52a**, **52b**. The support pole section **24b** preferably includes a pair of generally opposing apertures that are sized and configured to receive at least a portion of the pin **42** and the handle support members **52a**, **52b** preferably include an aperture that is sized and configured to receive at least a portion of the pin **42**. Each of the handle sections **38** preferably include handle support member receiving portions **54** that are sized and configured to receive at least a portion of a handle support member **52**. For example, as shown in **FIGS. 10 and 12**, the handle section **38a** may include the handle support member receiving portions **54a**, **54b**, **54c** and **54d**. The handle support member receiving portions **54** are preferably sized and configured to receive at least a portion of a handle support member **52** using a snap fit, a friction fit, and/or an

interference fit. The handle support member receiving portions **54** are also preferably sized and configured to slidably receive at least a portion of a handle support member **52**.

[0073] The handle support member receiving portions **54** and the handle support members **52** may also have one or more corresponding locking portions (such as outwardly extending portions and inwardly extending portions) to provide an interlocking connection. For example, as shown in **FIG. 12**, the handle support member receiving portion **54d** may include an outwardly extending portion **56**, which may be received and retained by a corresponding inwardly extending portion **58** of the handle support member **52b**. Similarly, the handle support member **52a** may include an outwardly extending portion **60**, which may be received and retained by a corresponding inwardly extending portion **62** of the handle support member receiving portion **54c**.

[0074] It will be appreciated that the handle support members **52** and the handle support member receiving portions **54** may have any suitable number of locking portions. The handle support members **52** and the handle sections **38** may also be separate components; however, all or a portion of a handle support members and the handle sections could be integrally formed, if desired. Further, the handle sections **38** and/or the handle **36** do not require any handle support sections **52** or the pin **42**, and the handle sections **38** and/or the handle **36** may be connected to the support pole section **24b** in any other suitable fashion.

[0075] As best seen in **FIG. 5**, the connecting member **44** preferably includes an elongated rod with opposing end portions. The connecting member **44** is preferably constructed from steel and with a generally rigid configuration. The connecting member **44** also may have a generally circular cross section and an angled portion proximate each end to facilitate connection to the locking member **28** and/or the trigger **40**. It will be appreciated that the connecting member **44** need not be rigid and it could be flexible such as a cable, a rope, a string, a wire and the like. Also, the connecting member **44** may be constructed from other materials and may have other suitable shapes and/or configurations. Also, the connecting member **44** may include a plurality of interconnected components, or the connecting member may have a unitary, one-piece construction. Additionally, as best seen in **FIG. 5**, at least a substantial portion of the connecting member **44** is disposed within a hollow interior portion of the support pole section **24b**; however, all or a portion of the connecting member may be disposed outside the support pole section **24b**. Further, it will be appreciated that the adjustment mechanism **34** and the locking member **28** need not be connected by the connecting member **44** and could be connected using other suitable structures.

[0076] As shown in **FIGS. 16-19**, the locking member **28** preferably has a generally U-shaped configuration including opposing wall portions **64a**, **64b** and an intermediate portion **66** extending between the wall portions. The wall portions **64a**, **64b** may respectively include apertures **68a**, **68b**, which are preferably sized and configured to receive at least a portion of the pin **30** to help connect the locking member **28** to the support pole section **24b**. The locking member **28** may also include a latch portion **70** with a projection that is sized and configured to releasably and/or selectively secure the support pole **12** or the support pole sections **24** in a desired position or height.

[0077] In greater detail, to releasably and/or selectively secure the support pole 12 or the support pole sections 24 in a desired position or height, the latch portion 70 preferably may move between a locked position and an unlocked position. In the locked position, at least a portion of the latch portion 70 may advance beyond an outer surface of the support pole section 24b, advance into or through a locking member receiving portion 32, and/or advance beyond an outer surface of the support pole section 24a. Thus, in the locked position, at least a portion of the latch portion 70 may engage at least a portion of the support pole section 24a and secure the support pole sections 24 in a generally fixed position, which may secure the basketball goal 14 at a generally fixed height. In the unlocked position, the latch portion 70 may retract within an outer surface of the support pole section 24a, retract from a locking member receiving portion 32, and/or retract within an outer surface of the support pole section 24b. Thus, in the unlocked position, the latch portion 70 may allow the support pole sections to move to adjust the length of the support pole 12 and/or the height of the support pole section 24b, which may allow one to adjust the height of the basketball goal 14.

[0078] The latch portion 70 of the locking member 28 preferably includes a curvilinear portion, which may help the latch portion 70 move between the locked and unlocked positions. The latch portion 70 may advantageously have a generally oblong cross section, which may help apply forces along a greater distance—which may help avoid more concentrated stresses applied against the support pole section 24a and/or against the locking member. The latch portion 70 may include a plurality of projections or other suitable structures and may have other suitable shapes and configurations. Also, the latch portion 70 may be integrally formed in the locking member 28 as part of a unitary one-piece structure, but the latch portion could be assembled with other separate components as part of the locking member.

[0079] The support pole 12, the support pole section 24a and/or the support pole section 24b may be sized and configured to have a range of movement. For example, the support pole sections 24 may be telescopically and/or slidably connected and the telescopic and/or sliding movement of the support pole sections may be restricted to a range of one or more relative positions. Also, for example, the rotational movement of the support pole section 24b and a mounting member (such as, the support pole section 24a) may be restricted to a range of one or more relative positions.

[0080] As shown in FIG. 20, the support pole 12 may include a bracket 72 that is preferably connected to the support pole section 24a. The bracket 72 and/or the support pole section 24b preferably each include one or more alignment members that are preferably sized and configured to help define the movement of the support pole section 24a and/or the support pole section 24b. The alignment members may include, for example, outwardly extending portions (such as a rib, protrusion, a flange or the like), inwardly extending portions (such as a slot, a groove, a notch, channel, recessed portion or the like) and/or other suitable structures.

[0081] As shown in FIGS. 5, 14 and 20, the support pole section 24b may include an elongated alignment member 74. The bracket 72 may include an alignment member 76 that is

sized and configured to be slidably coupled or disposed within the alignment member 74. Advantageously, the alignment members 74 and 76 may help, for example, define the rotational orientation and/or restrict the relative rotational movement of the support pole sections 24. Further, the length of the alignment member 74 may be sized and configured to define and/or restrict at least a portion of the telescopic and/or sliding movement of the support pole sections 24.

[0082] For example, as shown in FIGS. 6-7 and 20, the alignment member 74 may include one or more end portions 78 that define an upper or a lower boundary for the movement of the support pole sections 24, which may define an upper or lower boundary for the height of the basketball goal 14. More specifically, the end portion 78a may define a lower boundary for the height of the support pole section 24b and/or a lower boundary for the length of the support pole 12 and the end portion 78b may define an upper boundary for the height of the support pole section 24b and/or an upper boundary for the length of the support pole 12. It will be appreciated that the end portions 78a, 78b may be spaced apart from the top and bottom edges of the support pole section 24b to help define a desired boundary.

[0083] Accordingly, the end portions 78a, 78b of the alignment member 74 may define an upper boundary, a lower boundary, or both, for the length of the support pole 12 and/or the height of the support pole section 24b—and consequently, may define an upper boundary, a lower boundary, or both the height of the basketball goal 14. Advantageously, by defining an upper boundary, the alignment member 74 may help avoid unintentional disconnection of the support pole sections 24. Likewise, by defining a lower boundary, the alignment member 74 may advantageously help prevent damages to the adjustment mechanism 34 if unintentionally dropped. For example, the alignment member 74 may be sized and configured to prevent the adjustment mechanism 34, when unintentionally dropped, from contacting the support pole section 24a. However, it will be appreciated that the alignment member 74 need not define any such boundaries. For example, the alignment member 74 may extend through the top or bottom edges of the support pole section 24b. Further, the support pole 12 does not require any alignment members, such as the alignment members 74, 76.

[0084] As shown in FIGS. 21-23, the support pole 12 may include a bracket or collar 80 that is preferably connected to the support pole section 24a. The collar 80 may include alignment members 82, 84 that are sized and configured to be slidably coupled to the alignment member 74, and the alignment members 74, 82, 84 are preferably sized and configured to help define the movement of the support pole section 24a and/or the support pole section 24b, for example, as described above with reference to the alignment members 74, 76. The alignment members 82, 84 may be formed as separate components or may consist of a single component. Further, the alignment members 82, 84 may consist of separate components that are connected to the collar 80, but the alignment members 82, 84 may also be formed integrally with the collar 80 as part of unitary, one-piece construction.

[0085] Also, as shown in FIGS. 21-23, the collar 80 preferably includes a head portion 86 and a body portion 88.

At least a portion of the body portion **88** is preferably sized and configured to be received into a hollow interior portion of the support pole section **24a**. In addition, at least a portion of the body portion **88** may be positioned between the support pole sections **24a**, **24b**, and may be sized and configured to guide the relative movement of the support pole sections and/or help reduce friction between the support pole sections **24a**, **24b**. At least a portion of the head portion **86** of the collar **80** preferably is sized and configured to engage, abut and/or contact at least a portion of the support pole section **24a**, such as an edge **90**. For example, as shown in **FIG. 23**, the head portion **86** of the collar **80** may include a lip and the lip is preferably sized and configured to engage, abut, and/or contact at least a portion of the edge **90** of the support pole section **24a**.

[**0086**] As shown in **FIGS. 21-23**, a fastener **92** may be received into apertures **94**, **96** to help secure the collar **80** to the support pole section **24a**, and the fastener and the apertures may have a threaded configuration. For example, the fastener **92** may comprise a bolt, a screw, or other suitable fasteners. As shown in **FIG. 23**, a fastener **98** may be sized and configured to help the alignment member **84** of the collar **80** engage and/or contact at least a portion of the support pole section **24b**. With the alignment member **84** engaging and/or contacting the support pole section **24b**, the alignment member **84** may help secure the support pole **12** in a generally fixed length and/or help secure the support pole **24b** in at a particular height or relative position to the support pole section **24a**. This may be particularly helpful if, for example, the locking member **28** is unintentionally unlocked.

[**0087**] In greater detail, the fastener **98** may include a head **100** and a body **102**. The head **100** may include a knob, grip or other handle and the body **102** may be inserted into an aperture **104** of the support pole section **24a**. As the body **102** of the fastener **98** is received into the aperture **104**, the body may contact and/or exert a force against the alignment member **84**. The alignment member **84** is preferably constructed of a deformable material, which may deform or deflect in response to the exerted force to engage and/or contact at least a portion of the support pole section **24b**. The alignment member **84** preferably frictionally engages the alignment member **74**. With the alignment member **84** frictionally engaging the alignment member **74**, the alignment member **84** may help secure the support pole **12** in a generally fixed length and/or help secure the support pole **24b** at a particular height or relative position to the support pole section **24a**. The alignment member **84** is also preferably constructed of a resilient material, which may substantially return to its original shape when the exerted force is removed.

[**0088**] As shown in **FIG. 23**, the aperture **104** may be formed in a raised portion **106** of the support pole section **24a**. Also, the aperture **104** and the body **102** preferably have a threaded configuration to provide a more stable, adjustable connection between the fastener **98** and the support pole section **24a**.

[**0089**] The bracket **72** and/or the collar **80** may be connected to the support pole section **24a** using one or more fasteners or the like. Further, the bracket **72** and/or the collar **80** may be connected to the support pole section **24a** using a snap fit, a friction fit, and/or an interference fit. Also, if

desired, all or at least a portion of the bracket **72**, the collar **80**, and/or the alignment members **76**, **82**, **84** may be integrally formed in the support pole section **24a** as part of a unitary, one-piece construction.

[**0090**] As shown in **FIGS. 24-27**, the basketball system **10** may include an attachment assembly **108** that may be sized and configured to connect one or more braces **22** to the support pole **12**. The attachment assembly **108** preferably includes an attachment member **110**, which may include a pole receiving portion **112** sized and configured to receive and/or retain at least a portion of the support pole **12**. The attachment member **110** may have a generally C-shaped configuration, but may have other suitable shapes and/or configurations. As shown in **FIG. 24**, the attachment member **110** also preferably includes one or more clamp members **114**. The clamp members **114** are preferably sized and configured to help retain at least a portion of the support pole **12** within the pole receiving portion **112**. The clamp members **114** may include edges that contact, engage, abut, and/or bite into at least a portion of the support pole **12** to help secure the support pole **12** in a desired position. As best seen in **FIGS. 26 and 27**, the attachment assembly **108** may also include a spacer **116** and an elongated coupler **118**.

[**0091**] As shown in **FIGS. 24-27**, the attachment assembly **108** may include fasteners **120** that are connected to washers **122**, the braces **22**, the attachment member **110** and the coupler **118**. The apertures formed in the coupler **118** and the fasteners **120** may have a threaded configuration, which may be used to draw the fasteners **120** toward each other. As the fasteners **120** are drawn toward each other, the clamp members **114** may move from a first position in which at least a portion of the clamp members is spaced apart from the support pole **12** and a second position in which at least a portion of the clamp members **114** contact, engage, abut, and/or bite into at least a portion of the support pole **12**. The spacer **116** may be sized and configured to position the attachment member **110** and/or clamp members **114** in a desired configuration and/or position.

[**0092**] As shown in **FIGS. 24-27**, the attachment assembly **108** may be sized and configured to facilitate the telescopic, slidable, and/or movable connection of the support pole sections **24**. For example, because all or at least a substantial portion of the attachment assembly **108** may be disposed outside the path of the support pole section **24b**, the attachment assembly **108** may help facilitate telescopic, slidable and/or movable connection of the support pole sections **24**. In greater detail, because the attachment member **110** and/or the fasteners **120** may be positioned outside of a hollow interior portion of the support pole section **24a**, the braces **22** may be connected to the support pole section **24a** without significantly interfering with the telescoping movement of the support pole sections **24**. Accordingly, one or more apertures **32** may be disposed below the attachment assembly **108**. Likewise, an end portion of the support pole section **24b** may be disposed below the attachment assembly **108**, if desired.

[**0093**] It will be appreciated, however, that the attachment assembly **108** need not be used with a support pole including telescopically, slidably, or movably connected support pole sections, and the attachment assembly could be used with support poles having other suitable constructions. It will also be appreciated that the basketball system **10** does not require

the attachment assembly **108**, the braces **22** and/or the base **20**. Also, the braces **22** may be connected to the support pole **12** and/or to the base **20** in any other suitable fashions or manners depending, for example, upon the intended use or design of the basketball system.

[0094] The collars **72**, **80**, the handle **36**, the handle sections **38**, the handle support sections **52** and the trigger **40** may be constructed a relatively durable material, such as polypropylene plastic, and using an injection or extrusion molding process. The locking member **28** may be constructed from steel and may have a generally rigid construction. The attachment member **28** may be constructed from metal and may have a generally durable construction. It will be appreciated that the locking member **28**, the attachment member **28**, the collars **72**, **80**, the handle **36**, the handle sections **38**, the handle support sections **52** and the trigger **40** may be constructed of other suitable materials, including but not limited to other types of metals or plastics, and other materials with suitable characteristics. Further, it will be appreciated that the locking member **28**, the attachment member **28**, the collars **72**, **80**, the handle **36**, the handle sections **38**, the handle support sections **52** and the trigger **40** may be constructed using other suitable processes and may have other suitable shapes and/or configurations.

[0095] One skilled in the art will also appreciate that although the exemplary embodiments discussed above have been described with respect to support poles for basketball systems, these aspects and features may also be used in connection with other sports. For example, a volleyball net may be connected to, and extend between, a pair of support poles **12** that have an adjustable length. Advantageously, the support poles **12** may be adjusted to position the net at the standard height for men's volleyball, the standard height for women's volleyball, or other heights. It will also be appreciated that these aspects and features may also be used in connection with other types of sports.

[0096] Although this invention has been described in terms of certain preferred embodiments, other embodiments apparent to those of ordinary skill in the art are also within the scope of this invention. Accordingly, the scope of the invention is intended to be defined only by the claims which follow.

What is claimed is:

**1.** A basketball system comprising:

a basketball goal including a basketball backboard and a rim;

a support pole sized and configured to support the basketball goal, the support pole including a first support pole section and a second support pole section telescopically connected to the first support pole section, the first support pole section and the second support pole section being movable between a first position in which the support pole has a first length to support the basketball goal at a first height and a second position in which the support pole has a second length to support the basketball goal at a second height; and

an adjustment assembly sized and configured to selectively secure the first and second support pole sections in the first position and the second position, the adjustment assembly including a locking member sized and configured to pivot between a first position in which the

locking member secures the first and second support pole sections in a generally fixed position, and a second position in which the first and second support pole sections may telescopically move to adjust the length of the support pole.

**2.** The basketball system as in claim 1, wherein the adjustment assembly further comprises:

an adjustment mechanism including a handle and a trigger; and

a connecting member connecting the trigger to the locking member to allow the trigger to selectively move the locking member between the first position and the second position.

**3.** The basketball system as in claim 1, wherein the second support pole section includes a plurality of locking member receiving portions sized and configured to receive at least a portion of the locking member in the first position.

**4.** The basketball system as in claim 1, wherein the locking member includes a latch portion having a generally oblong cross section.

**5.** The basketball system as in claim 1, wherein the locking member includes a first wall portion, a second wall portion, and an intermediate portion defining a generally U-shaped configuration.

**6.** The basketball system as in claim 1, wherein the support pole further comprises a plurality of alignment members sized and configured to define at least a portion of the movement of the first and second support pole sections, the plurality of alignment members including an outwardly extending portion and an elongated inwardly extending portion sized and configured to slidably receive at least a portion of the outwardly extending portion.

**7.** The basketball system as in claim 6, wherein the first support pole includes the elongated inwardly extending portion and wherein the support pole further includes a collar and the collar includes the outwardly extending portion.

**8.** The basketball system as in claim 6, wherein the plurality of alignment members are sized and configured to define a lower boundary for the length of the support pole.

**9.** The basketball system as in claim 6, wherein the plurality of alignment members are sized and configured to define an upper boundary for the length of the support pole.

**10.** The basketball system as in claim 6, wherein the plurality of alignment members are sized and configured to restrict the relative rotational orientation of the first and second support pole sections.

**11.** A basketball system comprising:

a basketball goal including a basketball backboard and a rim;

a support pole sized and configured to support the basketball goal above a playing surface, the support pole comprising:

a first support pole section and a second support pole section movably connected to the first support pole section, the first support pole section and the second support pole section being movable between a first position in which the basketball goal is supported at a first height and a second position in which the basketball goal is supported at a second height; and

one or more alignment members sized and configured to define at least a portion of the movement of the first support pole section and second support pole section; and

an adjustment assembly sized and configured to selectively secure the first and second support pole sections in the first position and the second position, the adjustment assembly including a locking member that is sized and configured to move between a first position in which the locking member secures the first and second support pole sections in a generally fixed position, and a second position in which the first and second support pole sections may move to adjust the length of the support pole.

12. The basketball system as in claim 11, wherein the one or more alignment members are sized and configured to define a lower boundary for the length of the support pole.

13. The basketball system as in claim 11, wherein the one or more alignment members are sized and configured to define an upper boundary for the length of the support pole.

14. The basketball system as in claim 11, wherein the one or more alignment members are sized and configured to restrict the relative rotational orientation of the first and second support pole sections.

15. The basketball system as in claim 11, wherein the adjustment assembly further comprises:

an adjustment mechanism including a handle and a trigger; and

a connecting member connecting the trigger to the locking member.

16. The basketball system as in claim 11, wherein the locking member includes a latch portion having a generally oblong cross section.

17. A basketball system comprising:

a basketball goal including a basketball backboard and a rim;

a mounting member;

a first support pole section movably connected to the mounting member, the first support pole section being movable between a first position in which the basketball goal is supported at a first height and a second position in which the basketball goal is supported at a second height; and

an adjustment assembly sized and configured to selectively secure the first support pole section in the first position and the second position, the adjustment assembly comprising:

a locking member; and

an adjustment mechanism including a trigger sized and configured to move between a first position in which

the locking member secures the first support pole section in a generally fixed position, and a second position in which the first support pole section may move to adjust the height of the basketball goal.

18. The basketball system as in claim 17, wherein adjustment mechanism further includes a handle and wherein the adjustment assembly further includes a connecting member connecting the trigger and the locking member.

19. The basketball system as in claim 17, wherein the mounting member comprises a second support pole section.

20. The basketball system as in claim 17, wherein the locking member includes a projection having a generally oblong cross section, the projection sized and configured to move between a first position in which the projection secures the first support pole section in a generally fixed position, and a second position in which the first support pole section may move to adjust the height of the basketball goal.

21. A basketball system comprising:

a basketball goal including a basketball backboard and a rim;

a support pole including a first support pole section and a second support pole section telescopically connected to the first support pole section;

a base connected to the section support pole section;

at least one brace including a first end portion and a second end portion, the first end portion of the at least one brace connected to the base; and

an attachment assembly connected to the support pole and connected to the second end portion of the at least one brace;

the first support pole section being telescopically movable between a first position in which at least a portion of the first support pole section is at a first height below the attachment assembly and a second position in which at least a portion of the first support pole section is at a second height above the attachment assembly.

22. The basketball system as in claim 21, wherein the attachment assembly includes an attachment member sized and configured to bite into at least a portion of the support pole.

23. The basketball system as in claim 21, wherein the attachment assembly includes an attachment member having a generally C-shaped configuration.

24. The basketball system as in claim 21, wherein the attachment assembly includes an attachment member having at least one clamping member.

\* \* \* \* \*