

**(12) PATENT**  
**(19) AUSTRALIAN PATENT OFFICE**

**(11) Application No. AU 199730198 B2**  
**(10) Patent No. 725059**

(54) Title  
A fish hook and knot therefor

(51)<sup>6</sup> International Patent Classification(s)  
A01K 083/00 A01K 091/04

(21) Application No: 199730198 (22) Application Date: 1997.06.13

(87) WIPO No: W097/49280

(30) Priority Data

(31) Number	(32) Date	(33) Country
PO 0667	1996.06.25	AU
PO 1404	1996.08.02	AU

(43) Publication Date : 1998.01.14  
(43) Publication Journal Date : 1998.03.12  
(44) Accepted Journal Date : 2000.10.05

(71) Applicant(s)  
Jeffrey William Turner

(72) Inventor(s)  
Jeffrey William Turner; James Otter Turner

(74) Agent/Attorney  
GRIFFITH HACK,GPO Box 4164,SYDNEY NSW 2001

(56) Related Art  
US 5237772  
US 3834060  
US 3626629

OPI DATE 14/01/98 APPLN. ID 30198/97  
AOJP DATE 12/03/98 PCT NUMBER PCT/AU97/00373



AU9730198

(PCT)

(51) International Patent Classification <sup>6</sup> : A01K 83/00, 91/04		A1	(11) International Publication Number: <b>WO 97/49280</b>
			(43) International Publication Date: 31 December 1997 (31.12.97)
(21) International Application Number: PCT/AU97/00373		(81) Designated States: AL, AM, AT, AU, AZ, BA, BB, BG, BR, BY, CA, CH, CN, CU, CZ, DE, DK, EE, ES, FI, GB, GE, GH, HU, IL, IS, JP, KE, KG, KP, KR, KZ, LC, LK, LR, LS, LT, LU, LV, MD, MG, MK, MN, MW, MX, NO, NZ, PL, PT, RO, RU, SD, SE, SG, SI, SK, TJ, TM, TR, TT, UA, UG, US, UZ, VN, YU, ZW, ARIPO patent (GH, KE, LS, MW, SD, SZ, UG, ZW), Eurasian patent (AM, AZ, BY, KG, KZ, MD, RU, TJ, TM), European patent (AT, BE, CH, DE, DK, ES, FI, FR, GB, GR, IE, IT, LU, MC, NL, PT, SE), OAPI patent (BF, BJ, CF, CG, CI, CM, GA, GN, ML, MR, NE, SN, TD, TG).	
(22) International Filing Date: 13 June 1997 (13.06.97)		Published <i>117 Derby Street Penrith NSW 2751 Au</i> With international search report.	
(30) Priority Data: PO 0667 25 June 1996 (25.06.96) AU PO 1404 2 August 1996 (02.08.96) AU			
(71)(72) Applicant and Inventor: TURNER, Jeffrey, William [AU/AU]; Unit 4, 13 River Road, Wollstonecraft, NSW 2065 (AU). <del>TURNER, James, Offer</del>			
(74) Agent: SPRUSON & FERGUSON; G.P.O. Box 3898, Sydney, NSW 2001 (AU).			
<i>see folio 45</i> (72) TURNER, James, Offer			



(54) Title: A FISH HOOK AND KNOT THEREFOR

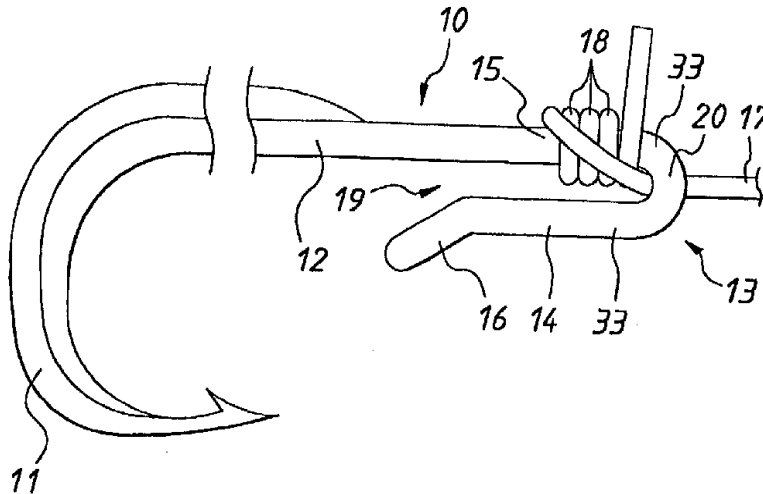

(57) Abstract

A fish hook (10) comprising: a hook portion (11); a shank (12) extending from the hook portion (11); and a line attachment portion (13) to engage a fishing line (17) to secure the fishing line (17) to the hook (10), said attachment portion (13) comprising a pair of legs (14, 15) which extend to a junction, with one of the legs (14, 15) having a free end (16) and the other leg being a continuation of the shank (12), said legs (14, 15) each having a line engagement portion (33), with the line engagement portions (33) being spaced by a distance of at least one time the diameter of the fishing line (17). A knot to secure the hook (10) and a method of forming it is also disclosed.

## A Fish Hook and Knot Therefor

Technical Field

The present invention relates to fishing hooks.

Background of the Invention

5 Fishing hooks have conventionally consisted of a hook portion from which there extends a shank. The shank terminates with an eyelet which cooperates with the fishing line to secure the hook to the fishing line.

10 Securing the line to a conventional fishing hook is reasonably tedious and time consuming. These problems are exacerbated in cold weather or if the user is wearing gloves. Still further, conventional attachment methods are known to fail in that the hook becomes detached.

15 The two most common knots used are the blood knot or several half hitches which, when tied by amateurs, result in a reduction of the achievable line strength by 30 to 50 % from the nominal line strength. This is due to the fact that today most mono-filament lines are very good in tensile strength but are weakened easily by heating and  
20 chain relocation. Most of the afore mentioned conventional knots cause the polymer chain to twist in both dimensions around sharp angles especially as the line tightens against itself in knot formation. These distortions create frictional heat and the knot and line wrapping does not  
25 allow generated heat to escape, thereby reducing the normal line strength significantly. The above problems are equally applicable to the construction of commercial fishing lines, in which the hooks are secured to the line by means of a mechanically constructed knot. These knots  
30 formed by machine in addition to the afore mentioned problems frequently over stress the line which can further increase the possibility of failure of the line.

35 From the above it follows that conventional fishing hooks with an eyelet onto which the fishing line is secured using conventional attachment knots does significantly limit the line strength, i.e. premature line breaking



75417-A

AMENDED SHEET  
IPE/AU

occurs.

**Summary of the Invention**

In accordance with a first aspect of the present  
5 invention there is provided a fish hook including a hook  
portion, a shank extending from the hook portion, and a line  
attachment portion to engage a fishing line to secure the  
fishing line to the hook, said attachment portion including  
10 two legs which extend from a junction, with a first of the  
legs having a free end which in use remains spaced from the  
secured leg, and a second leg being connected to the shank,  
wherein the second leg is arranged to extend in  
substantially the same direction as the shank, said legs  
15 each having a line engagement portion, with the line  
engagement portions, from the free end of the first leg  
substantially to the junction, being spaced by a distance of  
at least one times the diameter of the fishing line, the  
first leg being arranged such that a blood knot when tied  
20 from the fishing line at the attachment portion could be  
slid off along the second leg, and slid around the junction  
and shield along the first leg and over the free end of the  
first leg.

Preferably, an elongated clear space is defined  
between said line engagement portions, the clear space  
25 having a length several times the spacing between the line  
engagement portions.

Advantageously, the first leg terminates with an end  
portion which diverges away from the second leg.

Further, the line engaging portions are preferably  
30 spaced by a distance of between one and two times the  
fishing line diameter.



Preferably, the hook is formed from plastic or metal.

In accordance with a second aspect of the present invention there is provided a method of forming a knot when used to attach a fishing line to the fishing hook of the present invention, said method including the steps of  
5 locating two portions of the line together so that the line portions are generally co-extensive, wrapping the co-extensive portions about the shank to form pairs of convolutions, with each pair consisting of a convolution  
10 from each coextensive portion, a first one of the pairs being located closer to the hook portion and a second one of the pairs being located closer to the attachment portion, with said line extending from one of the coextensive portions of the first one of the pairs back upon itself to  
15 the other coextensive portion of the first one of the pairs so that the line forms a loop, passing said loop over said attachment portion, moving the convolutions towards the junction and applying a force to one or both of the lines extending from the pair of convolutions closest to the  
20 junction away from the convolutions so as to diminish the size of the loop without the loop being passed back over the attachment portion.

In accordance with a third aspect of the present invention there is provided a knot when used to secure the hook of the present invention, said knot including a pair of  
25 generally parallel coextensive line portions wound about one of said two legs to form pairs of convolutions and extending to a loop joining the line portions, the loop being formed around one of the two legs with said line portions passing  
30 between the loop and the pairs of convolutions.



It is an advantage of at least one embodiment of the present invention to provide a knot that reduces damaging effects to the fishing line during the tying of the knot as the tightening occurs around the shank of the hook thereby  
5 resulting in a larger diameter with a gentler bending rate when compared to a knot wherein the line is bent around itself (i.e. a smaller diameter). In at least one embodiment the shank acts as a heat sink for the fishing line thereby conducting frictional heat that may be created under a  
10 varying load away from the knot (i.e. the fishing line). It is another advantage of at least one embodiment of the invention to provide a knot configured such that tying occurs without excessive frictional resistance as the knot forms on the shank with little slippage (thus light tension)  
15 when compared to a knot wherein the tightening includes tightening the line against itself.

SECRET



twist per length of line in the knot thus reducing the chain damage due to the twisting of the line.

It is another advantage of at least one embodiment of the invention to provide a knot wherein the line spirals along the shank of the hook such that under load the line does not twist or rotate excessively but does elongate by slight slippage along the hook.

The invention may be more fully understood from the following description of preferred embodiments of the method, the hook and the knot of the present invention provided with the accompanying drawings.

**Brief Description of the Drawings**

In the figures

Figure 1 is a schematic side elevation of the steps of applying a fishing line to a fishing hook;

Figure 2 is a schematic side elevation of the fishing hook of Figure 1 with the fishing line attached thereto;

Figure 3 is a schematic top plan view of the fishing hook and line of Figure 2;

Figure 4 is a schematic bottom plan view of the fishing hook of Figure 2;

Figure 5 is a series of schematic illustrations of method steps of applying a fishing line to the fishing hook of Figure 1;

Figure 6 is a schematic side elevation of a hook;

Figure 7 provides four end elevations of different modifications of one hook portion of the hook of Figure 6; and

Figure 8 provides a side elevation of a modification of one portion of the hook of Figure 6.

**Detailed Description of the Preferred Embodiment**

In the accompanying drawings there is schematically depicted a fish hook 10. The fish hook 10 has a hook portion 11 extending to a shank 12. The shank 12 extends to an attachment portion 13. The attachment portion 13 in this embodiment is of a "U" configuration in that a pair of

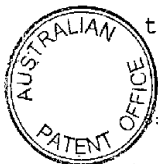

25417-A

AMENDED SHEET  
IPEA/AU

RECEIVED 23 JAN 1998

spaced legs 14 and 15 are provided. The leg 15 is a continuation of the shank 12, while the leg 14 has an end part 16 which diverges with respect to the other leg 15.

5 The fishing line 17 is attached to the hook 10 in the following manner.

The hook is held between the thumb and a finger with the hook portion 11 closer to the palm of the hand. The attachment portion is exposed as best seen in Figure 1(A).

10 The line is then gripped and wrapped around the shank three or four times. This is shown in Figure 1(D). In that regard it should be appreciated that the line can be wrapped clockwise or anti-clockwise about the shank 12.

15 The free end of the line is released and the other portion of the line extending from the shank 12 is gripped and pulled so that the coils 18 are pulled into the slot 19. The finished assembly is best seen in Figures 2 to 4.

20 Preferably the legs 14 and 15 have line engaging portions 33 separated by a distance of at least one times the diameter of the line 17. When the hook 10 is formed of plastics material, preferably the portions 33 are spaced by one to two times the line diameter. It is also preferred that the slot 19 defined between portions 33 has a length of approximately five times the diameter of the line 17.

The slot 19 could taper towards the end junction 20.

25 To remove the line 17, the coils 18 are moved down the shank 12 towards the hook portion 11.

30 In Figure 5 there is illustrated a knot 32. In this embodiment the fishing line 17 is held so as to provide two generally co-extensive line portions 20 and 21. The portions 20 and 21 are wrapped around the shank 11 as best seen in Figure 5(B) so as to form at least two sets 22 and 23 of convolutions. Each set 22 and 23 consists of a pair of convolutions 24 and 25 and 26 and 27. The set of convolutions 22 is closest to the hook portion of the hook 35 10, while the set of convolutions 23 are closest to the attachment portion 13. Extending from the set 22 is a loop



25417-A

AMENDED SHEET  
IPE/AU



28 which is passed over the attachment portion 13 so that the line portion 20 is on the side of the shank 11 that can be seen while the portion 21 is on the other side of the shank 11. The loop 28 is then located in the position shown in Figure 5(D). Thereafter, the convolutions are moved into engagement with the attachment portion 13 and one or preferably both of the line portions are pulled so as to decrease the size of the loop 29 so that a knot 32 is formed. (During this step it has to be ensured that the loop 28 is not passed back over the attachment portion 13.) Figure 5(E) is the top plan view of the knot 32, while 5(F) is the bottom plan view.

The above described preferred embodiments have the advantages of making it easy to attach the line 17 to the hook 10. The tedious steps of trying to thread the line through the eye of and then tying a conventional hook are eliminated.

In Figure 6 there is schematically depicted a fishing hook 40. The hook 40 is similar to the previous embodiments except that in the present instance the hook 40 is formed of plastics material and would preferably be moulded therefrom. The hook 40 has a hook portion 41 extending to a shank 42. The shank 42 extends to an attachment portion 43. The arrangement is basically the same as the previously discussed embodiments.

The shank 42 is of a "T" transverse cross section so as to provide a longitudinally extending ridge 46 extending from a base 47. The ridge 46 may also extend to the hook portion 41. The ridge 46 may be straight as illustrated in Figure 7(B) or may follow a curved path as shown in Figure 7(A). As a further alternative, the ridge 46 may be provided with barbs as shown in Figure 7(C) and 7(D). As a further alternative the hook portion 41 may terminate with a barbed end 48 provided with smaller barbed portions 49 as shown in Figure 8. The ridge 46 may include the barbs to aid in holding bait on the hook portion 41.



S:25417-A

The hook portion 41 may also be of a triangular transverse cross section as shown by the cross sections 50.

It would be appreciated by a person skilled in the art that numerous variations and/or modifications may be made  
5 to the present invention as shown in the specific embodiment without departing from the spirit or scope of the invention as broadly described. The present embodiment is, therefore, to be considered in all respects to be illustrative and not restrictive.

10 In the claims that follow and in the summary of the invention, except where the context requires otherwise due to express language or necessary implication, the word "comprising" is used in the sense of "including", i.e. the features specified may be associated with further features in various embodiments of the invention.

8  
7  
6  
5  
4  
3  
2  
1



The Claims Defining the Invention are as Follows:

1. A fish hook including:
  - a hook portion;
  - a shank extending from the hook portion; and
  - 5 a line attachment portion to engage a fishing line to secure the fishing line to the hook, said attachment portion including two legs which extend from a junction, with a first of the legs having a free end which in use remains spaced from a second leg, and the second
  - 10 leg being connected to the shank, wherein the second leg is arranged to extend in substantially the same direction as the shank, said legs each having a line engagement portion, with the line engagement portions, from the free end of the first leg substantially to the junction, being spaced by a distance of at least one times the diameter of
  - 15 the fishing line: the legs being arranged such that a blood knot when tied from the fishing line at the attachment portion of the second leg could be slid off along the second leg, and slid around the junction and slide along the first leg and over the free end of the
  - 20 first leg.
2. The hook of claim 1, wherein an elongated clear space is defined between said line engagement portions, the clear space having a length several times the spacing
- 25 between the line engagement portions.
3. The hook of claims 1 or 2, wherein said first leg terminates with an end portion which diverges away from the second leg.
4. The hook of any one of claims 1 to 3 and wherein
- 30 the line engaging portions are spaced by a distance of between one and two times the fishing line diameter.
5. The hook of any one of claims 1 to 4 when formed from plastic or metal.

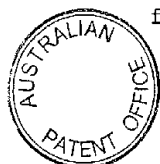
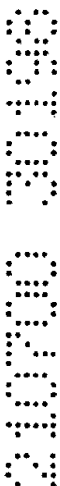

6. A method of forming a knot when used to attach a fishing line to the hook of any one of claims 1 to 5, said method including the steps of:

5 locating two portions of the line together so that the line portions are generally co-extensive;  
wrapping the co-extensive portions about the shank to form pairs of convolutions, with each pair consisting of a convolution from each coextensive portion, a first one of the pairs being located closer to the hook portion and a second one of the pairs being located closer to the attachment portion, with said line extending from one of the coextensive portions of the first one of the pairs back upon itself to the other coextensive portion of the first one of the pairs so that the line forms a loop;  
10 passing said loop over said attachment portion;  
moving the convolutions to said retaining means and applying a force to one or both of the lines extending from the pair of convolutions closest to the retaining means away from the convolutions so as to diminish the size of the loop without the loop being passed back over the attachment portion.

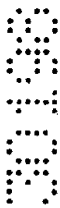

7. A knot when used to secure the hook of any one of claims 1 to 5, said knot including:

25 a pair of generally parallel coextensive line portions wound about one of said two legs to form pairs of convolutions and extending to a loop joining the line portions, the loop being formed around one of the two legs with said line portions passing between the loop and the pairs of convolutions.

30 8. A fish hook substantially as hereinbefore described with reference to the accompanying drawings.

9. A knot substantially as hereinbefore described with reference to Figure 5 of the accompanying drawings.

35 10 A method of tying a fishing line to a fishing hook substantially as hereinbefore described with reference to Figure 5 of the accompanying drawings.



Dated this 20<sup>th</sup> day of July 2000

JEFFREY WILLIAM TURNER

5 By his Patent Attorney

GRIFFITH HACK

SECRET



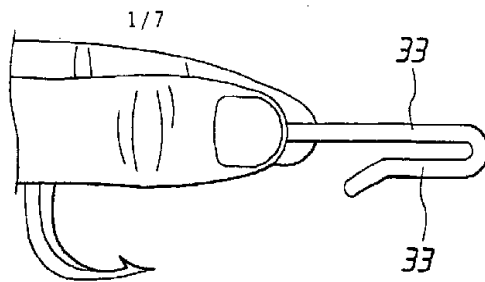

FIG. 1(A)

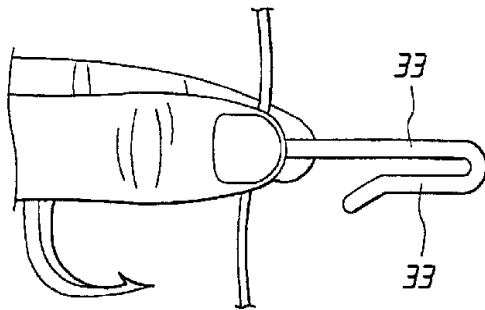

FIG. 1(B)

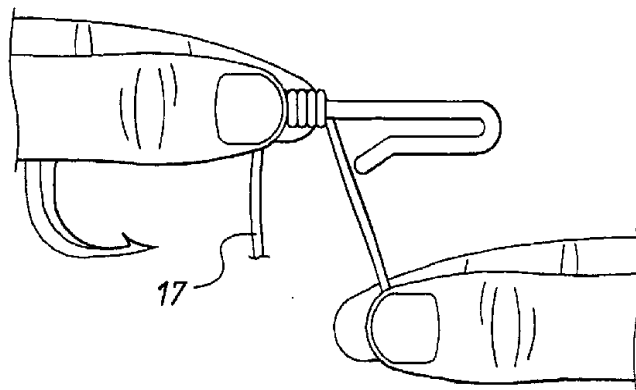

FIG. 1(C)

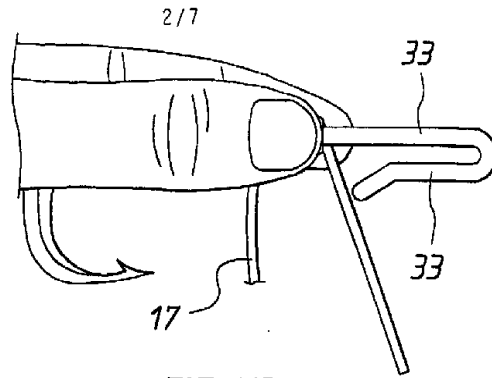

FIG. 1(D)

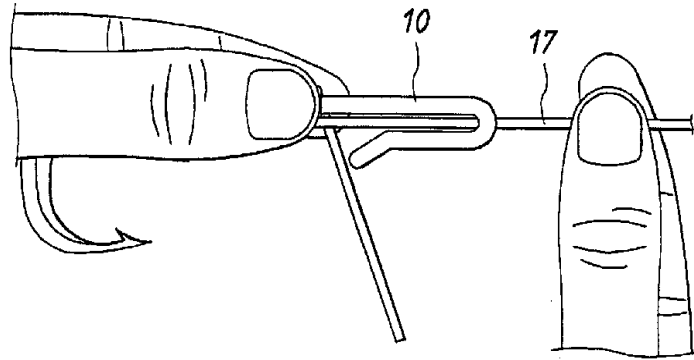

FIG. 1(E)

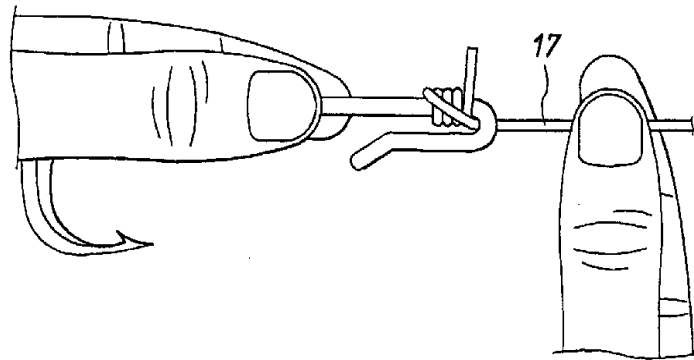

FIG. 1(F)

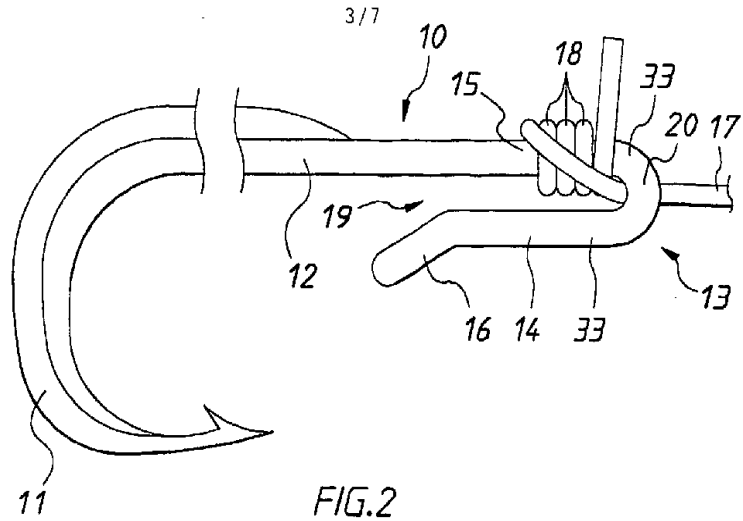

FIG. 2

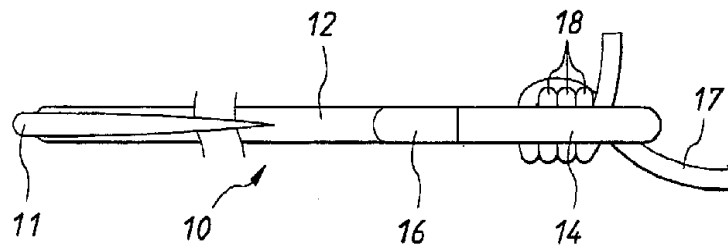

FIG. 3

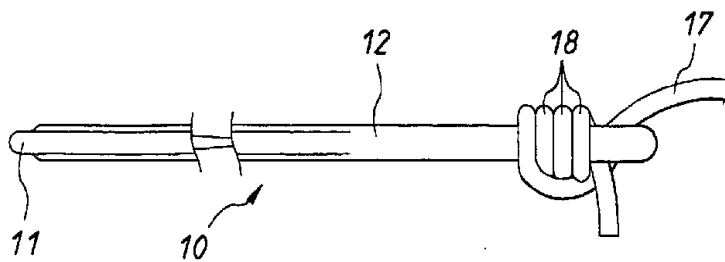

FIG. 4



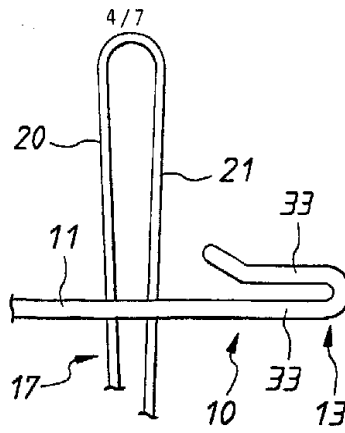

FIG. 5(A)

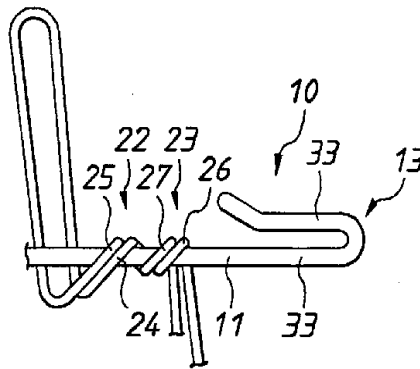

FIG. 5(B)

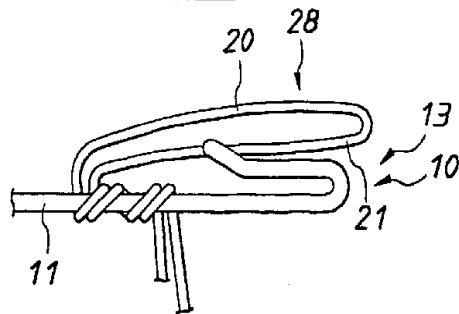

FIG. 5(C)

RECEIVED 23 JAN 1998

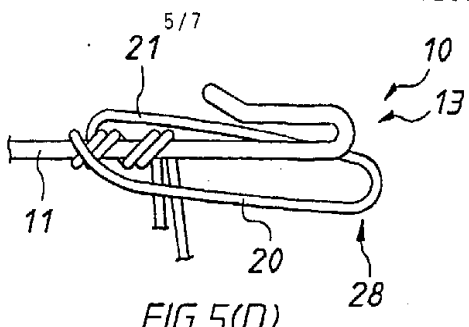

FIG.5(D)

AMENDED SHEET  
IPER/AU

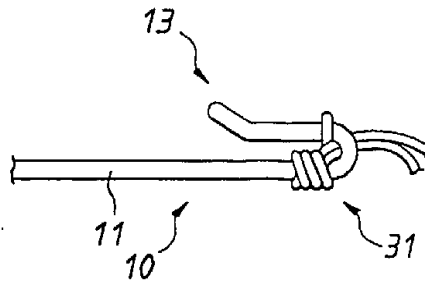

FIG. 5(E)

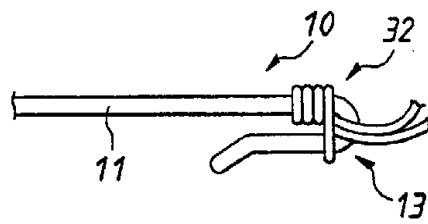

FIG. 5(F)

RECEIVED 23 JAN 1998

7/7

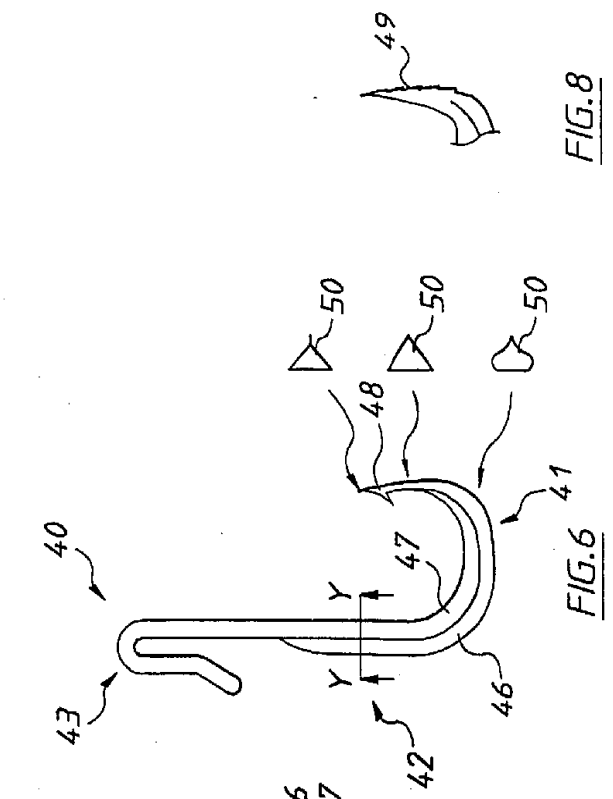

FIG. 6

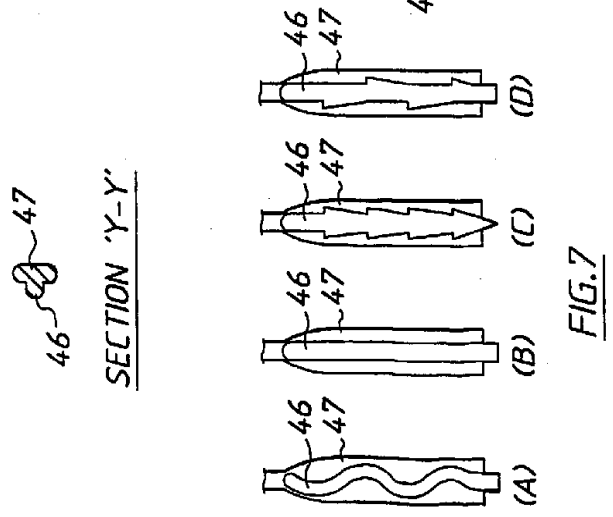

FIG. 7



FIG. 8

AMENDED SHEET  
IPE/AU