



(86) Date de dépôt PCT/PCT Filing Date: 2016/12/21
 (87) Date publication PCT/PCT Publication Date: 2017/06/29
 (45) Date de délivrance/Issue Date: 2023/12/05
 (85) Entrée phase nationale/National Entry: 2018/06/19
 (86) N° demande PCT/PCT Application No.: NL 2016/050902
 (87) N° publication PCT/PCT Publication No.: 2017/111585
 (30) Priorité/Priority: 2015/12/21 (EP15201598.8)

(51) Cl.Int./Int.Cl. *B01D 53/58* (2006.01),
C05C 1/00 (2006.01)
 (72) Inventeurs/Inventors:
PUCI, GIUSY ELISA, NL;
DOBREE, JOEY, NL
 (73) Propriétaire/Owner:
STAMICARBON B.V., NL
 (74) Agent: SMART & BIGGAR LP

(54) Titre : PRODUCTION DE NITRATE D'AMMONIUM-UREE
 (54) Title: UREA AMMONIUM NITRATE PRODUCTION

(57) **Abrégé/Abstract:**

The invention relates to a process for the production of urea ammonium nitrate, a system and a method of modifying a plant. The process comprises treating ammonia-containing off-gas resulting from the production of ammonium nitrate (AN off-gas) with acidic scrubbing liquid in a finishing treatment section having a gas inlet in fluid communication with a gas outlet of a finishing section of a urea production unit, wherein the finishing section is adapted to solidify urea liquid, and wherein said finishing treatment section is adapted to subject ammonia-containing off-gas of the finishing section to treatment with an acidic scrubbing liquid.

(12) INTERNATIONAL APPLICATION PUBLISHED UNDER THE PATENT COOPERATION TREATY (PCT)

(19) World Intellectual Property
Organization
International Bureau(10) International Publication Number
WO 2017/111585 A1(43) International Publication Date
29 June 2017 (29.06.2017)

- (51) **International Patent Classification:**
B01D 53/58 (2006.01) *C05C 1/00* (2006.01)
- (21) **International Application Number:**
PCT/NL2016/050902
- (22) **International Filing Date:**
21 December 2016 (21.12.2016)
- (25) **Filing Language:** English
- (26) **Publication Language:** English
- (30) **Priority Data:**
15201598.8 21 December 2015 (21.12.2015) EP
- (71) **Applicant:** STAMICARBON B.V. [NL/NL]; Mercator 3, 6135 KW Sittard (NL).
- (72) **Inventors:** PUCI, Giusy Elisa; c/o Mercator 3, 6135 KW Sittard (NL). DOBREE, Joey; c/o Mercator 3, 6135 KW Sittard (NL).
- (74) **Agent:** JANSEN, C.M.; V.O., Carnegieplein 5, 2517 KJ Den Haag (NL).
- (81) **Designated States** (unless otherwise indicated, for every kind of national protection available): AE, AG, AL, AM, AO, AT, AU, AZ, BA, BB, BG, BH, BN, BR, BW, BY, BZ, CA, CH, CL, CN, CO, CR, CU, CZ, DE, DJ, DK, DM, DO, DZ, EC, EE, EG, ES, FI, GB, GD, GE, GH, GM, GT, HN, HR, HU, ID, IL, IN, IR, IS, JP, KE, KG, KH, KN,

KP, KR, KW, KZ, LA, LC, LK, LR, LS, LU, LY, MA, MD, ME, MG, MK, MN, MW, MX, MY, MZ, NA, NG, NI, NO, NZ, OM, PA, PE, PG, PH, PL, PT, QA, RO, RS, RU, RW, SA, SC, SD, SE, SG, SK, SL, SM, ST, SV, SY, TH, TJ, TM, TN, TR, TT, TZ, UA, UG, US, UZ, VC, VN, ZA, ZM, ZW.

- (84) **Designated States** (unless otherwise indicated, for every kind of regional protection available): ARIPO (BW, GH, GM, KE, LR, LS, MW, MZ, NA, RW, SD, SL, ST, SZ, TZ, UG, ZM, ZW), Eurasian (AM, AZ, BY, KG, KZ, RU, TJ, TM), European (AL, AT, BE, BG, CH, CY, CZ, DE, DK, EE, ES, FI, FR, GB, GR, HR, HU, IE, IS, IT, LT, LU, LV, MC, MK, MT, NL, NO, PL, PT, RO, RS, SE, SI, SK, SM, TR), OAPI (BF, BJ, CF, CG, CI, CM, GA, GN, GQ, GW, KM, ML, MR, NE, SN, TD, TG).

Declarations under Rule 4.17:

- as to applicant's entitlement to apply for and be granted a patent (Rule 4.17(ii))
- as to the applicant's entitlement to claim the priority of the earlier application (Rule 4.17(iii))
- of inventorship (Rule 4.17(iv))

Published:

- with international search report (Art. 21(3))



WO 2017/111585 A1

(54) **Title:** UREA AMMONIUM NITRATE PRODUCTION

(57) **Abstract:** The invention relates to a process for the production of urea ammonium nitrate, a system and a method of modifying a plant. The process comprises treating ammonia-containing off-gas resulting from the production of ammonium nitrate (AN off-gas) with acidic scrubbing liquid in a finishing treatment section having a gas inlet in fluid communication with a gas outlet of a finishing section of a urea production unit, wherein the finishing section is adapted to solidify urea liquid, and wherein said finishing treatment section is adapted to subject ammonia-containing off-gas of the finishing section to treatment with an acidic scrubbing liquid.

Title: UREA AMMONIUM NITRATE PRODUCTION

The invention is in the field of the production of a solution of urea ammonium nitrate in water (UAN). The invention also pertains to a system for producing UAN and to a method of modifying a plant.

5 **Background of the Invention**

Urea ammonium nitrate (UAN) is an aqueous solution of urea and ammonium nitrate and is used as fertilizer. A process for producing UAN generally comprises producing ammonium nitrate in an ammonium nitrate section (AN production section), forming urea in a urea production unit, and combining said
10 produced ammonium nitrate and urea to produce urea ammonium nitrate in a urea ammonium nitrate section (UAN production section).

The production of ammonium nitrate solution involves the neutralisation reaction of gaseous ammonia with concentrated nitric acid solution according to the
15 following reaction:



The production of ammonium nitrate solution generally results in an off-gas (AN off-gas), in particular from the neutralization reaction of ammonia with nitric acid. Because the formation of ammonium nitrate is a highly exothermic reaction,
20 the AN off-gas generally comprises water vapor, residual ammonia and entrained droplets from the reaction medium. The droplets can comprise ammonium nitrate and/or nitric acid. Accordingly, AN off-gas may for instance comprise CO₂, NH₃, water, ammonium nitrate, N₂, O₂ and nitric acid. The AN off-gas is usually subjected to condensation and the condensate is for instance passed in part to the
25 UAN production section.

Some general desires for improving a process comprising producing UAN include reducing steam consumption (increasing energy efficiency) and reducing emissions and emission points, in particular of ammonia. It is also desired to

reduce waste streams, improve product recovery and reduce the amount of make-up water and acid used for scrubbing. Such advantages are desirably obtained for new plants (grass-roots plants) as well as by modifying or revamping existing plants. Equipment costs and other capital expenditures are preferably minimized.

5 **Summary of the Invention**

In order to better address one or more of the foregoing desires, the invention, in one aspect, provides a process for the production of urea ammonium nitrate, comprising:

10 (a) subjecting ammonia and carbon dioxide to urea forming conditions so as to obtain an aqueous urea solution,

 (b) purifying the aqueous urea solution in a recovery section to remove residual ammonium carbamate so as to form a purified aqueous urea solution, and optionally subjecting at least part of the purified aqueous urea solution to evaporation so as to form concentrated urea liquid (urea melt),

15 (c) subjecting ammonia and nitric acid to ammonium nitrate forming conditions so as to form an aqueous ammonium nitrate solution;

 (d) combining said aqueous ammonium nitrate solution and at least a part of the purified aqueous urea solution and/or concentrated urea liquid in a urea ammonium nitrate section so as to obtain an aqueous solution of urea ammonium
20 nitrate;

 (e) treating ammonia-containing off-gas resulting from the production of ammonium nitrate (AN off-gas) with acidic scrubbing liquid in a finishing treatment section having a gas inlet in fluid communication with a gas outlet of a finishing section of a urea production unit, wherein the finishing section is adapted
25 to solidify urea liquid, wherein said finishing treatment section is adapted to subject ammonia-containing off-gas of the finishing section to treatment with an acidic scrubbing liquid.

The invention also relates to a system for the production of at least urea and urea ammonium nitrate, comprising:

30 (a) a urea production unit comprising a finishing section, wherein the finishing section has a gas outlet for ammonia-containing off-gas,

(b) an ammonium nitrate section for producing ammonium nitrate in fluid communication with a source of nitric acid and a source of ammonia, having an outlet for aqueous ammonium nitrate solution and an outlet for off-gas,

5 (c) a urea ammonium nitrate section comprising a unit having an inlet in fluid connection with said outlet for aqueous ammonium nitrate solution and an inlet for receiving urea liquid, for combining said ammonium nitrate solution and said urea liquid, and having an outlet for urea ammonium nitrate solution, and

(d) a finishing treatment section having a gas inlet in fluid connection with said gas outlet for off-gas of said finishing section, adapted to subject ammonia-containing off-gas of the
10 finishing section to treatment with an acidic scrubbing liquid,

wherein said finishing treatment section comprises a gas inlet in fluid communication with said outlet for off-gas of said ammonium nitrate section.

The invention also relates to a method of modifying a plant, wherein the plant comprises an ammonium nitrate section for reacting ammonia and nitric acid under ammonium nitrate
15 forming conditions, a finishing section adapted to solidify a urea liquid, and a finishing treatment section having a gas inlet in fluid communication with a gas outlet of said finishing section, adapted to subject ammonia-containing off-gas of the finishing section to treatment with an acidic scrubbing liquid, wherein the method comprises adding a connection for fluid communication between an outlet for off-gas from said ammonium nitrate section and an gas
20 inlet of said finishing treatment section, such as piping or tubing.

In another aspect, the invention relates to a process for the production of urea ammonium nitrate comprising (a) subjecting ammonia and carbon dioxide to urea forming conditions in a high pressure urea synthesis section of a first urea production unit so as to obtain an aqueous urea solution, (b) purifying the aqueous urea solution in a recovery section of the first urea
25 production unit to remove residual ammonium carbamate so as to form a purified aqueous urea solution; (c) subjecting ammonia and nitric acid to ammonium nitrate forming conditions in an ammonium nitrate production unit so as to form an aqueous ammonium nitrate solution and a first ammonia-containing off-gas; (d) combining the aqueous ammonium nitrate solution (i) with at least a part of the purified aqueous urea solution, and/or (ii) with a concentrated urea liquid in
30 a urea ammonium nitrate section so as to obtain an aqueous solution of urea ammonium nitrate; (e) treating the first ammonia-containing off-gas resulting from the production of ammonium nitrate with

an acidic scrubbing liquid in a treatment section, wherein either the first urea production unit comprises a finishing section that produces a second ammonia-containing off-gas and is adapted to solidify a urea liquid, and the treatment section is in fluid communication with a gas outlet of said finishing section for the second ammonia-containing off-gas of the finishing section, or the treatment section is in fluid communication with a gas outlet for third ammonia-containing off-gas of a finishing section of a second urea production unit, wherein the finishing section of the second urea production unit produces the third ammonia-containing off-gas and is adapted to solidify urea liquid.

In another aspect, the invention relates to a plant for the production of at least urea and urea ammonium nitrate, comprising: (a) a urea production unit comprising a high pressure urea synthesis section, a recovery section, and a finishing section, wherein the urea production unit is configured for forming urea from ammonia and carbon dioxide under urea forming conditions in the high pressure urea synthesis section so as to obtain an aqueous urea solution, wherein the recovery section is configured for removal of residual ammonium carbamate so as to obtain a purified aqueous urea solution from the aqueous urea solution, (b) an ammonium nitrate section comprising an ammonium nitrate production unit for producing ammonium nitrate in fluid communication with a source of nitric acid and a source of ammonia, having an outlet for an aqueous ammonium nitrate solution and an outlet for a first ammonia-containing off-gas, wherein the finishing section of the urea production plant is adapted to solidify a first urea liquid and has a gas outlet for a second ammonia-containing off-gas, (c) a urea ammonium nitrate section comprising a unit having an inlet in fluid connection with the outlet for the aqueous ammonium nitrate solution and an inlet for receiving a part a second urea liquid, for combining the ammonium nitrate solution and the second urea liquid, and having an outlet for a urea ammonium nitrate solution, and (d) a treatment section is in fluid connection with the gas outlet for the second ammonia containing off-gas of the finishing section, adapted to subject the second ammonia-containing off-gas of the finishing section to treatment with an acidic scrubbing liquid, wherein the treatment section is in fluid communication with the outlet for the first ammonia-containing off-gas of the ammonium nitrate section.

In another aspect, the invention relates to a method of modifying an existing plant into the plant as described herein, wherein the existing plant comprises an ammonium nitrate section, a urea production unit, a treatment section, and a urea ammonium nitrate section, wherein the urea production unit comprises a high pressure urea synthesis section, a recovery section and an

evaporation section, and a finishing section, wherein the ammonium nitrate section is configured for reacting ammonia and nitric acid under ammonium nitrate forming conditions and is in fluid communication with a source of nitric acid and a source of ammonia and has an outlet for aqueous ammonium nitrate solution and an outlet for a first ammonia-containing off-gas, 5 wherein the finishing section is adapted to solidify a first urea liquid, and wherein the finishing section has a gas outlet for a second ammonia-containing off-gas, wherein the treatment section has a first gas inlet in fluid communication with the gas outlet for a second ammonia containing off-gas of the finishing section, adapted to subject the second ammonia-containing off-gas of the finishing section to treatment with an acidic scrubbing liquid, wherein the urea ammonium 10 nitrate section comprises a unit having an inlet in fluid connection with the outlet for aqueous ammonium nitrate solution and an inlet for receiving a second urea liquid, for combining the ammonium nitrate solution and the second urea liquid, and having an outlet for a urea ammonium nitrate solution, wherein the method comprises adding a connection for fluid communication between the outlet for a first ammonia containing off-gas from the ammonium 15 nitrate section and the treatment section.

In another aspect, the invention relates to a process for the production of urea ammonium nitrate comprising (a) subjecting ammonia and carbon dioxide to urea forming conditions in a high pressure urea synthesis section of a first urea production unit so as to obtain an aqueous urea solution; (b) purifying the aqueous urea solution in a recovery section of the first urea 20 production unit to remove residual ammonium carbamate so as to form a purified aqueous urea solution; (c) dividing the purified aqueous urea solution stream of step (b) into three streams: (i) a first purified aqueous urea solution stream, (ii) a second purified aqueous urea solution stream, and (iii) a third purified aqueous urea solution stream; (d) adding an additive to the second purified aqueous urea solution stream downstream of the dividing, wherein the additive is 25 selected from the group consisting of anti-caking agents and granulation aids, subjecting the second purified aqueous urea solution stream with the additive to evaporation in an evaporation section, so as to form a concentrated urea liquid with the additive, and subjecting at least part of the concentrated urea liquid with the additive to solidification in a finishing section of the first urea production unit; (e) diluting the third purified aqueous urea solution stream with water 30 downstream to the dividing; (f) subjecting ammonia and nitric acid to ammonium nitrate forming conditions in an ammonium nitrate production unit so as to form an aqueous ammonium nitrate solution and a first ammonia-containing off-gas; (g) combining the aqueous ammonium nitrate

solution and (i) the first purified aqueous urea solution stream, and/or (ii) the concentrated urea liquid with the additive, in a urea ammonium nitrate section so as to obtain an aqueous solution of urea ammonium nitrate; (h) treating the first ammonia-containing off-gas resulting from the production of ammonium nitrate with an acidic scrubbing liquid in a treatment section, wherein
5 the first urea production unit comprises the finishing section that produces a second ammonia-containing off-gas and is adapted to solidify the concentrated urea liquid with the additive, and the treatment section is in fluid communication with a gas outlet of the finishing section for the second ammonia-containing off-gas of the finishing section; and (i) recycling all or part of a spent acidic scrubbing liquid utilized in the treatment section to the urea ammonium nitrate
10 section.

Brief Description of the Drawings

Figure 1 shows a process scheme for a non-limiting example of a process and system according to the invention.

Detailed Description of the Invention

15 The invention is based on the judicious insight to integrate the treatment of ammonia-containing off-gas resulting from the production of ammonium nitrate (AN off-gas) with a treatment of ammonia-containing off-gas of a finishing section (finishing off-gas) with an acidic scrubbing liquid.

The process of the invention accordingly comprises treating ammonia-containing off-gas resulting from the production of ammonium nitrate (AN off-gas) with acidic scrubbing liquid in a finishing treatment section.

In the process, AN off-gas is sent to a gas inlet of the finishing treatment section so as to be subjected to treatment with the acidic scrubbing liquid. Preferably, at least part of the AN-off gas is supplied into the finishing treatment section. Preferably at least part of the AN off-gas is contacted with, combined with and/or mixed with finishing off-gas that is supplied to the finishing treatment section. Hence, at least part of the AN off-gas is treated in a finishing treatment section. In this way, the integration may provide for more efficient treatment of AN off-gas and/or finishing off-gas.

In contrast to prior art processes, a step of condensing the AN off-gas can be omitted. This allows for eliminating the condenser used in some prior art processes.

The AN off-gas comprises at least ammonia when supplied into the finishing treatment section. In the process, ammonia-containing AN off-gas is sent to a gas inlet of said finishing treatment section so as to be subjected to treatment with the acidic scrubbing liquid in the finishing treatment section.

In the process, at least part of the AN off-gas enters the finishing treatment section as gaseous stream (which may contain droplets and entrainments). The process can for example comprise combining a gaseous AN off-gas stream with gaseous ammonia-containing off-gas of the finishing section. The gaseous AN off-gas stream can for example have the same composition at the gas inlet of the finishing treatment section as at the outlet of the AN production section. Preferably, at least 50 vol% of the AN off-gas, more preferably at least 90 vol%, or essentially all of the AN off-gas stream as obtained from the AN production section is combined as gaseous stream with a finishing off-gas stream to give a combined gaseous stream. The combined gaseous stream is treated in the finishing treatment section. The AN off-gas stream may amount to for example from 0.5 to 10 vol% of the finishing off-gas, such as from 1.0 to 5.0 vol.%, although the process is not limited to a particular ratio between AN off-gas and finishing off-gas. The relative amount of AN off-gas depends for instance on the capacity of the urea finishing section.

Advantageously, treatment of AN off-gas in a finishing treatment section allows for a net reduction of ammonia emission. The process of the invention surprisingly allows for treating additional AN off-gas in the finishing treatment section with no or only a small increase of the emission of ammonia and urea dust
5 from the finishing treatment section. Advantageously, aerosols in the AN off-gas can be captured in the finishing treatment section, for example by a scrubber such as a venturi scrubber, which can for example be additional to the scrubber used for scrubbing with acid liquid. Since the finishing treatment section is generally designed for removing particles from the finishing off-gas, it can advantageously be
10 used for removing aerosol droplets from the AN off-gas, furthermore in combination with ammonia removal from the AN-off gas.

In addition, the presence of urea dust in the off-gas from the finishing section may provide more feeding material to enlarge particles entrained in AN off-gas during a quench step, if used, thereby further improving the removal of such
15 particles.

Hence, the process of the invention allows for eliminating the ammonia emission from the conventional separate treatment section for AN off-gas, which can for example be about 25 mg ammonia / Nm³ dry air. In this way, ammonia emission from the AN production section can be decreased or eliminated while
20 ammonia emission from the finishing treatment section can for example remain the same, or possibly decrease, or increase less than the ammonia emission decrease for the AN production section. In this way, the process may allow for a reduction of total ammonia emission and emission points.

Moreover, with the process of the invention advantageously less equipment
25 is required for the AN production section, for example by eliminating a scrubber and condenser for AN off-gas in the AN production section, and auxiliary equipment thereof such as pumps. Hence, in a preferred embodiment, all or essentially all of the AN off-gas is passed to the finishing treatment section as gaseous stream without an intermediate step of condensing, or without an
30 intermediate step of scrubbing, or even without any intermediate steps yielding liquid streams. By eliminating a separate scrubber for the AN off-gas, the need for recovering ammonium nitrate and nitric acid from scrubbing liquid thereof is also

eliminated. By eliminating the condenser of the AN production section no condensate needs to be treated.

In a preferred embodiment, the process does not involve condensing off-gas resulting from the production of ammonium nitrate between the urea ammonium
5 nitrate section and the finishing treatment section.

The process also allows for reduced water consumption by a more efficient use of make-up water, as a combined stream is treated, for example by 10-20%. The process further allows for a reduction of power consumption, for example of up to 2 kWh/ton, such as compared to a process with a separate scrubber for AN off-gas.

10 The finishing section is for example the finishing section of the urea production unit wherein aqueous urea solution and/or concentrated urea liquid are produced. In another embodiment, the finishing section is a finishing section of a second urea production unit from which no urea liquid is supplied to the urea ammonium nitrate section. In such case, the first urea production unit does not
15 necessarily have a finishing section.

The aqueous urea solution, the purified aqueous urea solution and the concentrated urea liquid are some of the streams of urea liquid in the process of the invention. The term "urea liquid" can also refer to a urea-containing liquid stream of a second urea production unit.

20 Preferably, the process comprises recycling scrubbing liquid utilized in the finishing treatment section to the UAN production section. Preferably, the scrubbing liquid is recycled such that it is at least in part included in the aqueous solution of urea ammonium nitrate. The process may for example comprise combining scrubbing liquid utilized in the finishing treatment section with the
25 aqueous ammonium nitrate solution, the purified aqueous urea solution and/or concentrated urea liquid.

The process comprises subjecting ammonia-containing off gas of the finishing section and AN off-gas to a treatment with an acidic scrubbing liquid, in particular in the same finishing treatment section. Accordingly, various
30 components of both the off-gas streams are removed from the off-gas and end up in a liquid stream (liquid recycle stream), in particular urea and ammonium nitrate. For example, the scrubbing uses a circulating solution as scrubbing liquid, with

additional make-up water. A purge flow is obtained from the scrubber, usually with 10% - 60% urea by weight, which provides the liquid recycle stream.

The process preferably comprises including at least part of the liquid recycle stream, such as all, in the UAN solution. Preferably, at least part of the liquid
5 recycle stream, such as all, is combined with an ammonium nitrate containing stream in the UAN production section, for example in the mixing unit. Herein, the liquid recycle stream refers to the scrubbing liquid utilized in the finishing treatment section after withdrawal from that section.

This preferred embodiment advantageously avoids the need for a separate
10 treatment of said liquid recycle stream. Moreover, this embodiment allows for recovering for instance ammonium nitrate and/or urea from the off-gasses, thereby allowing for a higher UAN production. This embodiment may also allow for recovering nitric acid from the AN off-gas, thereby allowing for reduced nitric acid consumption in the AN production section. In addition, it can allow for adjusting
15 the concentration of the UAN solution. A particular advantage of this embodiment is that urea in the finishing off-gas can optionally be recovered into UAN rather than in a urea product stream. Accordingly, the process allows for eliminating the recycling of any additives added to the urea, such as anti-caking agents and granulation aids, in particular formaldehydes, back into a urea production unit.

20 Recycling scrubbing liquid utilized in the finishing treatment section to the UAN production section is in particular advantageous if a part of the urea liquid is used as very pure urea product or is used for the production of such urea product. Examples of such urea products are Diesel Exhaust Fluid (DEF) and urea products which are suitable for the preparation of DEF by adding demineralized water
25 (together referred to as DEF products). DEF is generally an aqueous urea solution with maximum 0.3 wt.% biuret and maximum 0.2 wt.% of alkalinity, in particular <0.2 wt.% ammonia, with 32.5 wt.% urea. DEF is injected in the tail gas of combustion engines to react with NO_x to reduce NO_x emission. Presence of contaminations in DEF is not desirable; in particular the presence of formaldehyde
30 and other anti-caking agents is unwanted. DEF is generally produced by diluting a urea liquid, such as purified aqueous urea solution, or by dissolving urea granules

with demineralized water. The urea liquid or urea granules accordingly should also have a very low level of biuret, alkalinity and other contaminations.

Accordingly, the process preferably comprises a step of preparing a urea product from a part of a stream of urea liquid of the urea production unit having the finishing section, wherein the urea product is a DEF product. Preferably, the DEF product has maximum 0.3 wt.% biuret and maximum 0.2 wt.% of alkalinity, in particular <0.2 wt.% ammonia, and comprises maximum 0.10 wt.% additives, preferably less than 0.010 wt.% additives, or for example less than 0.010 wt.% formaldehyde, and at least 30 wt.% urea, based on total weight of the product.

Preferably, the product is essentially free of formaldehyde. Preferably the process further comprises adding an additive to another part of said stream of urea liquid, for example an anti-caking agent such as formaldehyde. Hence, a preferred process comprises dividing a stream of urea liquid of the urea production unit having the finishing section in at least two parts, and adding an additive to one of said streams downstream of said dividing, wherein downstream is defined with respect to said stream, and preparing a DEF product from the other stream, wherein said additive is preferably formaldehyde, and wherein the stream with said additive is subjected to solidification in the finishing section, wherein the solidification is preferably granulation. In such process, the off-gas from the solidification is scrubbed in the finishing treatment section and the liquid recycle stream obtained with the scrubbing is included in the UAN product, for example supplied to the UAN production section.

Accordingly, a process for the production of a solid urea product, a DEF product and UAN preferably comprises producing UAN and a urea liquid, using a part of the urea liquid for producing a DEF product, and using another part of the urea liquid for producing a solid urea product by adding an additive, such as formaldehyde, and solidifying the urea, such as by granulating, wherein finishing off-gas is obtained. The off-gas comprises urea, ammonia and said additive. At least part of the urea is recovered from the off-gas into a recycle stream, for example by scrubbing, and at least part of said recycle stream is included in the UAN product. The process preferably does not comprise supplying the recycle stream into a stream from which the DEF product is prepared. This process can in principle be

used independently of the feature of supplying AN off-gas to a finishing treatment section, although the combination is preferred.

A suitable process for DEF preparation is described in for example EP1856038A1 and comprises using a urea aqueous solution obtained directly from
5 or after the recovery section of the urea melt plant, and diluting the urea aqueous solution with water to obtain the desired solution. In terms of the present invention, for example the purified aqueous urea solution can be diluted to prepare DEF.

The process comprises subjecting ammonia and carbon dioxide to urea
10 forming conditions so as to obtain an aqueous urea solution.

The urea can be synthesized by any suitable method. A frequently used process for the preparation of urea according to a stripping process is the carbon dioxide stripping process as for example described in Ullmann's Encyclopedia of Industrial Chemistry, Vol. A27, 1996, pp 333-350. In this process, a high pressure
15 synthesis section is followed by one or more recovery sections. The synthesis section comprises for example a reactor, a stripper, and a condenser. The synthesis section is operated at high pressure, such as between 12 and 18 MPa and preferably in between 13 and 16 MPa. In the synthesis section the urea solution leaving the urea reactor is fed to a stripper in which a large amount of non-
20 converted ammonia and carbon dioxide is separated from the aqueous urea solution. Such a stripper can be a shell and tube heat exchanger in which the urea solution is fed to the top part at the tube side and a carbon dioxide feed to the synthesis is added to the bottom part of the stripper. At the shell side, steam is added to heat the solution. The urea solution leaves the heat exchanger at the
25 bottom part, while the vapor phase leaves the stripper at the top part. The vapor leaving said stripper contains ammonia, carbon dioxide and a small amount of water. Said vapor is condensed by formation of ammonium carbamate in a falling film type heat exchanger or a submerged type of condenser that can be a horizontal type or a vertical type. A horizontal type submerged heat exchanger is described in
30 Ullmann's Encyclopedia of Industrial Chemistry, Vol. A27, 1996, pp 333-350. The heat released by the exothermic carbamate condensation reaction in said condenser is usually used to produce steam that is used in a downstream urea processing

section for heating and concentrating the urea solution. Since a certain liquid residence time is created in a submerged type condenser, a part of the urea reaction takes already place in said condenser. The formed solution, containing ammonium carbamate, water and urea together with the non-condensed ammonia, carbon dioxide and inert vapor is sent to the reactor. In the reactor the above mentioned reaction from carbamate to urea approaches the equilibrium. The ammonia to carbon dioxide molar ratio in the urea solution leaving the reactor is generally in between 2.5 and 4 mol/mol. It is also possible that the condenser and the reactor are combined in one piece of equipment (for example a pool reactor). An example of this piece of equipment is described in Ullmann's Encyclopedia of Industrial Chemistry, Vol. A27, 1996, pp 333-350. The formed urea solution leaving the urea reactor is supplied to the stripper and the inert vapor containing non-condensed ammonia and carbon dioxide is for example sent to a scrubbing section operating at a similar pressure as the reactor. In that scrubbing section the ammonia and carbon dioxide is scrubbed from the inert vapor. The formed carbamate solution from the downstream recovery system is used as absorbent in that scrubbing section.

Said vapor from said reactor can for example also be sent directly to the ammonium nitrate section for neutralization (i.e. reaction with nitric acid so as to form ammonium nitrate). The urea solution leaving the stripper in this synthesis section can for example have a urea concentration of at least 45 % by weight and preferably at least 50 % by weight thereby allowing for treatment in a single recovery system downstream the stripper. This urea solution is referred to as aqueous urea solution. These preferences also apply for the second urea production unit, if used.

In the process of the invention, at least part of the aqueous urea solution is purified in a recovery section. In this section, aqueous urea solution is purified to remove residual ammonium carbamate so as to form a purified aqueous urea solution. The recovery section comprises for example a heater, a liquid/gas separator and a condenser. The pressure in this recovery section is for instance between 200 to 6000 kPa. For example, a low pressure recovery section (2-7 bar) can be used, or a medium pressure recovery section (12-40 bar) followed by a low

pressure recovery section. In the heater of the recovery section the bulk of ammonia and carbon dioxide is separated from the urea and water phase by heating the urea solution. Usually steam is used as heating agent. The purified aqueous urea solution contains a small amount of dissolved ammonia and carbon dioxide and leaves the recovery section. Optionally, at least part of the purified aqueous urea solution is sent to a downstream urea processing section, also referred to as urea evaporation section or evaporation section. Herein, purified aqueous urea solution is optionally subjected to evaporation of water so as to form a concentrated urea liquid that is generally referred to as a urea melt.

10 The invention is not limited to any particular urea production process. Other processes and plants include those that are based on technology such as total recycle plants, the HEC process developed by Urea Casale, the ACES process developed by Toyo Engineering Corporation and the process developed by Snamprogetti. All of these processes, and others, may be used in the process of the invention.

15 The process of the invention comprises subjecting ammonia and nitric acid to ammonium nitrate forming conditions so as to form an aqueous ammonium nitrate solution. This step also results in an off-gas. The unit, reactor or section in which this reaction is carried out, can be referred to as AN production section.

20 Ammonium nitrate can for example be produced by reacting ammonia with a strong solution of nitric acid while maintaining the pH of the solution within narrow boundaries. Ammonia is for example used in its anhydrous form as gas and the nitric acid is for example concentrated (typical concentration range: 40 to 80 wt.%, such as about 60 wt.%). Via an exothermic neutralization reaction, the ammonium nitrate solution is readily formed, typically at a concentration of about 25 70% to 95%, such as 83% to 88%, for example with pH of about 7.

The AN production section can for instance comprise a neutralizer reactor based on a U-type combination of a circulator tube and mixing tube with a separation vessel reactor. The reaction is for example performed at 0.15 MPa and 30 135-165 °C.

Optionally, the process may comprise preparing solid ammonium nitrate products from a part of the ammonium nitrate, such as prills or granules, wherein

preferably the excess water is evaporated to an ammonium nitrate (AN) content of 95% to 99.9% concentration.

Nitric acid used in the production of ammonium nitrate can be obtained as an external feed. Preferably, the nitric acid is produced on site. Accordingly, the process optionally comprises oxidizing anhydrous ammonia to nitric oxide, for example in the presence of a catalyst, and reacting nitric oxide with oxygen to form nitrogen dioxide. The process optionally comprises absorbing nitrogen dioxide in water to form nitric acid and nitric oxide, or reacting nitrogen dioxide with oxygen and water to form nitric acid. Accordingly, the system for the process of the invention optionally comprises a unit for the production of nitric acid. This unit will generally be fed from external sources and has an outlet for nitric acid that is in fluid communication with an inlet for nitric acid of the unit for the production of ammonium nitrate.

Ammonia used in the AN production section can for example at least in part be obtained from off-gas of the urea production unit and/or from the UAN production section. Preferably, also ammonia-containing off-gas from the urea production unit and/or from the urea ammonium nitrate section is sent to a gas inlet of the finishing treatment section.

Accordingly, the process may comprise supplying to the AN production section ammonia containing off-gas, such as overhead vapors, from the urea synthesis section, the recovery section, and/or the urea evaporation section.

The off-gas may for instance be obtained from a recovery section of the urea production unit, wherein ammonium carbamate in the urea synthesis solution is decomposed to carbon dioxide and ammonia, typically at low pressure (0.1 – 1 MPa, in particular 0.2 – 0.7 MPa), and/or at medium pressure (1 - 4 MPa, preferably 1.5 - 3.0 MPa).

The process optionally further comprises passing off-gas from a section of the urea production unit other than the finishing section, for example from the urea evaporation section, to the finishing treatment section. For example, at least part of a stream comprising water vapor evaporated in the urea evaporation section can be supplied to the finishing treatment section.

The process comprises combining aqueous ammonium nitrate solution and at least some urea liquid in a urea ammonium nitrate section (UAN production section) so as to obtain an aqueous solution of urea ammonium nitrate (UAN).

In the process of the invention, a part of the purified aqueous urea solution
5 and/or concentrated urea liquid is combined with aqueous ammonium nitrate solution. Accordingly, the aqueous ammonium nitrate solution is combined with purified aqueous urea solution in case the process does not involve subjecting at least part of the purified aqueous urea solution to evaporation, and the aqueous ammonium nitrate solution is combined with purified aqueous urea solution and/or
10 concentrated urea liquid if the process involves subjecting at least part of the purified aqueous urea solution to evaporation. However, this is not essential and that in principle urea supplied to the UAN production section can be obtained from any source.

In a preferred embodiment a stream of concentrated urea liquid supplied to
15 the UAN production section comprises a minor part of the total amount of urea liquid supplied to the UAN production section. This allows for adjustment and control of the urea concentration in the UAN production section.

Optionally, a part of the purified aqueous urea solution obtained from the recovery section of the urea production unit can be supplied to the UAN production
20 section, whereas another part can be supplied to the evaporation section and subsequently to the finishing section. Accordingly, the urea concentration of the urea liquid supplied to the UAN production section can for example be different from the urea concentration of urea liquid supplied to the finishing section.

The UAN production section preferably comprises a mixing unit, for
25 instance comprises a static mixer or a pipe mixer, for example a series of static mixers. The process preferably comprises mixing aqueous ammonium nitrate solution and urea liquid.

The UAN products obtained with the present process contain for example 28
wt.% to 32 wt.% of total nitrogen and typically of from 29 wt.% to 38 wt.% urea and
30 of from 36 wt.% to 48 wt.% of ammonium nitrate, with the remainder being water.

In the process of the invention, a urea production unit comprises a finishing section adapted to solidify urea liquid. Usually, the urea liquid is concentrated

before being subjected to solidification. The finishing section is for example the finishing section of the urea production unit wherein aqueous urea solution and/or concentrated urea liquid are produced.

5 The process optionally comprises solidifying urea liquid in the finishing section.

The solidification in the finishing section results in ammonia-containing off gas (finishing off-gas). The solidification for example comprises prilling, granulation, and/or pastillation of urea in the finishing section. The solidification in the finishing section preferably comprises exposing concentrated urea liquid to
10 an air stream so as to obtain solid urea particles. The use of such air stream results in finishing off-gas. Accordingly, the finishing section has a gas outlet in fluid communication with a gas inlet of a finishing treatment section adapted to subject ammonia-containing off-gas of the finishing section to treatment with an acidic scrubbing liquid.

15 This finishing section may for example be a prilling tower, granulation section, pelletizing section, or a section or equipment based on any other finishing technique. A granulation section may for example be a fluidized bed-granulation, or a drum granulation, or a pan- granulation, or any other similar granulation device. The main function of this finishing section is the conversion of a urea liquid, for
20 example urea melt, into a stream of solidified particles. To transfer the urea from the liquid phase into the solid phase, the heat of crystallization has to be removed. Moreover, usually some sensible heat is removed from the solidified urea particles, in order to cool them to a temperature that is suitable for further processing and handling, including safe and comfortable storage and transport of this final
25 product. The resulting total removal of heat in the finishing section is usually done by evaporation of water and/or by cooling with air. For water evaporation, the water enters the finishing section either as part of the urea liquid, or is sprayed as liquid water at an appropriate place in the finishing process. Usually most of the heat is removed by cooling with air. Usually an amount of air equal to 3 - 30 kg of
30 air per kg of final solidified product is applied, preferably 3-10 kg. This is the typical off-gas of the finishing section. In the finishing section the air comes into direct contact with the urea melt and with the solidified urea particles. This leads

to contamination of the air with urea dust and ammonia. Depending on the nature of the finishing section (prilling/granulation, type of granulation, conditions selected in granulation), the amount of urea dust present in the air may vary widely, values in the range of 0.05% to 10% by weight (with respect to the final product flow) having been observed. For a finishing section based on granulation, the amount of dust more typically is in a range of from 2% to 8% by weight. Urea in the finishing off-gas is mainly present as urea dust comprising particles with a diameter less than 500 μm , with a large fraction of particles smaller than 10 μm , such as sub-micron particles. Generally, this dust is carried along by the air stream when the air stream leaves the finishing section as off-gas. This presence of urea dust in the finishing off-gas usually makes a treatment comprising urea dust removal desirable, either for environmental or for efficiency considerations, before the air can be vented into the atmosphere. The removal of urea dust is challenging per se, since the amounts of off-gas (mainly air) are enormous, whilst the concentration of urea dust is low. An example airstream is of the order of 750 000 Nm^3/h . A typical concentration of urea dust therein is about 2 wt.%. Further, part of the urea dust is of a submicron size. Satisfying current standards implies the need to remove a major part of this submicron dust.

The solidification process may also comprise pelletizing, for example as described in WO 2006/111331. In such process, urea-comprising particles are produced in a pelletizer, comprising a feeding device, a belt and a device to remove the formed pellets from the belt, by feeding a urea containing liquid stream to the feeding device from which droplets of the liquid are dosed to the belt, whereon the urea-containing droplets solidify and cool to a temperature of $< 55\text{ }^\circ\text{C}$. The formed urea-containing particles are removed from the belt.

In the process of the invention, a finishing treatment section is involved having a gas inlet in fluid communication with a gas outlet of the finishing section, adapted to subject ammonia-containing off-gas of the finishing section (finishing off-gas) to treatment with an acidic scrubbing liquid. The treatment with an acidic scrubbing liquid results in removal of at least part of the urea dust and/or ammonia. Hence, the process may comprise scrubbing finishing off-gas. Scrubbing

for example comprises adding scrubbing liquid into a gas stream, usually in counter-current flow.

The finishing treatment section comprises at least one scrubber for scrubbing with acidic scrubbing liquid. The finishing treatment section may
5 comprise additional scrubbers for scrubbing with acidic scrubbing liquids or other liquids.

Suitable types of scrubbers include for example venturi scrubbers, packed bed scrubbers, impingement scrubbers, and sieve tray scrubbers. In a venturi scrubber the effluent gas is forced or drawn through a venturi tube having a
10 narrow "throat" portion. As the air moves through the throat it is accelerated to a high velocity. A scrubbing liquid in the form of droplets, typically of water, is added to the venturi, usually at the throat, and enters the gas flow. The water droplets used are generally many orders of magnitude larger than the contaminant particles to be collected and, as a consequence, accelerate at a different rate
15 through the venturi. The differential acceleration causes interactions between the water droplets and the contaminant particles, such that the contaminant particles are collected by the water droplets. Aerosol droplets of AN off-gas can be considered as contaminant particles for the purpose of their removal in a venturi scrubber. The collection mechanisms involve, primarily, collisions between the particles and
20 the droplets and diffusion of particles to the surface of the droplets. In either case, the particles are captured by the droplets. Depending on the size of the contaminant particles, one or the other of these mechanisms may predominate, with diffusion being the predominant collection mechanism for very small particles, and collision or interception being the predominant mechanism for larger particles.
25 A venturi scrubber can also be efficient at collecting highly soluble gaseous compounds by diffusion. A detailed description of these scrubbing mechanisms is discussed in Chapter 9 of Air Pollution Control Theory, M. Crawford, (McGraw-Hill 1976).

The finishing treatment section may comprise a single venturi scrubber or a
30 plurality of venturi scrubbers. Further, one or more venturi scrubbers can themselves comprises one or more venturi tubes.

A venturi scrubber usually comprises three sections: a converging section, a throat section, and a diverging section. The inlet gas stream enters the converging section and, as the area decreases, gas velocity increases. Liquid is introduced either at the throat or at the entrance to the converging section.

5 The inlet gas, forced to move at extremely high velocities in the small throat section, shears the liquid from its walls, producing an enormous number of very tiny droplets. Particle and gas removal occur in the throat section as the inlet gas stream mixes with a fog of tiny liquid droplets. The inlet stream then exits through the diverging section, where it is forced to slow down.

10 In case of a finishing treatment section comprising a scrubber, the treatment section may comprise sections for one or more pre-treatments or post-treatments. For instance, a venturi scrubbing method as described in WO 2015/002535 can be used. Such method comprises quenching off-gas to a temperature below about 45°C and/or to a temperature decrease of at least 50 °C,
15 and subjecting the quenched off-gas to scrubbing using at least one venturi scrubber. Quenching comprises adding aqueous quenching liquid to a gas stream, preferably by spraying, more preferably using an atomization nozzle, such as through a jet nozzle, for example co-currently with the gas stream. Quenching generally provides a liquid saturation near equilibrium. Preferably the quenching
20 stream has a temperature of below 45°C, more preferably below 40°C, most preferably below 35°C. The typical air temperature of the off-gas exiting a finishing section of a urea plant, such as in fluid bed granulation, is about 110°C. After quenching, the temperature is preferably below 45°C. Accordingly, the temperature of the gas stream is lowered by typically more than 50°C, preferably more than
25 60°C, and most preferably more than 65°C. Preferably, the liquid is sprayed in such a way and consistency that liquid droplets are formed that are so small that the droplets evaporate quickly and a liquid saturation in the vapor near equilibrium is reached within a short time, for example with a droplet size of less than 700 µm or less than 500 µm, or less than 100 µm.

30 In addition, a method such as described in WO 2015/072854 can be used. In such method, the gas stream is subjected to quenching in at least two stages in series, using an upstream quenching liquid and a downstream quenching liquid,

with the terms upstream and downstream being defined with reference to the flowing direction of the gas stream, wherein soluble particulate matter dissolves in the aqueous quenching liquid and wherein the downstream quenching liquid has a lower concentration of dissolved said particulate matter than the upstream quenching liquid. Such quenching
5 may provide for condensation of water on particles to be removed, thereby increasing their particle size, such that they are better removed in a venturi scrubber.

In a preferred embodiment, the finishing treatment section comprises a plurality of venturi scrubbers, operated in parallel. Preferably, the finishing treatment section is so designed that these parallel venturi tubes can be operated independently of each other, i.e.
10 the number of venturi tubes used at the same time, can be adapted during the process as desired.

A preferred venturi scrubber comprises a so-called MMV-section (micro-mist venturi). The MMV-section consists of multiple parallel venturis. In the MMV-section large quantities of liquid are sprayed in the throat of the venturis co-current with the gas-
15 flow through single phase nozzles, creating a consistent and adjustable liquid droplet-size, typically in a range of from 50 μm to 700 μm . The liquid droplet size is one of the parameters that can be used to control the efficiency of dust-removal.

A preferred system is that provided by Envirocare, comprising a quenching section and downstream thereof a MMV-section.

20 In a packed bed scrubber, separation is usually achieved by contact between the gas and the scrubbing liquid over a random packed bed. In an impingement scrubber, separation is usually achieved by inertia through a central impingement plate. For example, an off-gas stream enters the unit from the bottom and flows upward through a series of trays, each containing perforations. Scrubbing liquid is introduced from above the
25 top tray and cascades downward to the lower trays. The gas stream passes through the perforations and accelerates. This results in a fluidized zone of liquid and gas. An impingement scrubbing unit is usually furnished with a final demister section. Yet a further option for the scrubber is a sieve tray scrubber. Herein, liquid gas contact occurs on the sieve tray. For

example, a liquid stream flows horizontally while the gas passes through the sieves.

Yet a further option is a finishing treatment section comprising a wet electrostatic precipitator (WESP). Wet electrostatic precipitators of this general
5 type are known and described in prior art patents including U.S. patent numbers 1,339,480; 2,722,283; 4,389,225; 4,194,888; 6,106,592; and the prior art discussed and cited therein.

The finishing treatment section preferably comprises two parts in series, a part for scrubbing with acidic scrubbing liquid and a urea dust removal part. The
10 parts are optionally separate compartments. The dust removal part, such as a venturi scrubber, is preferably upstream (with respect to the off-gas stream) of the part for scrubbing with acidic scrubbing liquid.

In one embodiment, in addition to the AN plant, also a calcium ammonium nitrate plant is present. Calcium ammonium nitrate or CAN, also known as nitro-
15 limestone, is a widely used inorganic fertilizer. One variety of calcium ammonium nitrate is made by adding powdered limestone/calcium carbonate to ammonium nitrate; another, fully water-soluble version, is a mixture of calcium nitrate and ammonium nitrate, which crystallizes as a hydrated double salt:
 $5\text{Ca}(\text{NO}_3)_2 \cdot \text{NH}_4\text{NO}_3 \cdot 10\text{H}_2\text{O}$.

20 The finishing section of the CAN plant (in either process) produces a CAN off-gas, gas which can also be scrubbed in the finishing treatment section. The finishing treatment section wherein also the CAN off-gas is scrubbed, comprises 2 separate compartments in series for scrubbing with acidic scrubbing liquid, designed to allow the spent scrubbing liquids of each compartment to be used
25 differently. Generally, the compartment for scrubbing CAN off-gas is positioned downstream of the compartment for scrubbing AN off-gas.

The scrubber may comprise an overflow of the acidic scrubber part. The acidic scrubbing is for removing ammonia.

As mentioned above, the utilized scrubbing liquid from the finishing
30 treatment section, can be sent to the mixing unit for the UAN synthesis. In the event of the presence of a CAN plant, this will generally require first removing a calcium containing salt solution. In an interesting embodiment, said utilized

scrubbing liquid can itself be used as a UAN product stream. Accordingly, the scrubbing liquid can be merged with a UAN product stream, or it can be stored in a tank for later use.

In a preferred embodiment, ammonia-containing off-gas resulting from the production of ammonium nitrate is combined with ammonia-containing off-gas of the finishing section to provide a combined gas stream and the combined gas stream is subjected to scrubbing to remove droplets and particles and subsequently to scrubbing with acidic scrubbing liquid in said finishing treatment section.

If the finishing treatment section comprises one or more venturi scrubbers, the gaseous stream of AN off-gas is preferably introduced into the finishing treatment section upstream of one or more, or all, of the venturi scrubbers, in particular upstream of the venturi tubes. This can help to scrub entrainments from the gas flow. Optionally, the AN off-gas is supplied into or upstream of a quenching step upstream of a venturi step. This can advantageously provide for growth of the particles entrained in the AN off-gas.

The finishing treatment section for example comprises a venturi scrubber or a WESP, more preferably a combination of, in series, a wet scrubber (such as a tray scrubber) and, a venturi scrubber, with the venturi scrubber more preferably downstream of the wet scrubber. More preferably, the venturi scrubber comprises a plurality of venturi tubes in parallel. In another preferred embodiment, a WESP is positioned downstream of the wet scrubber, or downstream of the Venturi scrubber, or most preferably in series after the wet scrubber and the Venturi scrubber. Optionally, the finishing treatment section comprises a scrubber for scrubbing with acidic scrubbing liquid downstream of the venturi scrubber and/or WESP.

The invention also provides as mentioned a method of modifying a plant, wherein the method comprises adding a connection for fluid communication between an outlet for off-gas from said ammonium nitrate section and a gas inlet of said finishing treatment section, such as piping or tubing.

The method is usually a method for modifying or revamping a pre-existing plant. The plant can be of various types and the method may comprise additional steps prior to adding said connection. The method may be a method for modifying a

plant for producing urea ammonium nitrate and a solid urea product. Preferably, the plant comprises, before the modification, a condensation unit for condensing a part of the off-gas from said ammonium nitrate section and the method involves eliminating or bypassing said condensation unit.

5 The method may also be part of a method for modifying an ammonium nitrate plant, wherein the method further comprises adding a urea production unit and adding a UAN production section. Preferably, the plant comprises, before the modification, a condensation unit for condensing a part of the off-gas from said ammonium nitrate section and the method involves eliminating or bypassing said
10 condensation unit. The method may also be part of a method for modifying a plant for the production of UAN comprising a urea production unit, wherein the method further comprises expansion of the urea production unit by adding a finishing section.

 The method may also be part of a method for modifying a urea plant
15 including a finishing section, wherein the method further comprises adding an ammonium nitrate section.

 The invention also relates to a system for the production of at least urea and urea ammonium nitrate, comprising as mentioned (a) a urea production unit (b) an ammonium nitrate section, (c) a urea ammonium nitrate section and (d) a finishing
20 treatment section wherein said finishing treatment section comprises a gas inlet in fluid communication with said outlet for off-gas of said ammonium nitrate section.

 Preferably, the inlet for receiving urea liquid of said urea ammonium nitrate section is in fluid connection with said urea production unit comprising a finishing section. Preferably, the urea production unit comprises a high pressure urea
25 synthesis section comprising a high pressure stripper and a carbamate condenser and a urea reactor, or an integrated carbamate condenser and a urea reactor, wherein said urea production unit further comprises a recovery section and an evaporation section. Preferably, the ammonium nitrate section comprises an inlet in fluid communication for off-gas with one or more of said high pressure synthesis
30 section, recovery section and evaporation section.

 Preferably, the finishing treatment section comprises an outlet for a liquid stream in fluid communication with a point downstream of said outlet for

ammonium nitrate solution, such as with an inlet of said mixing unit. Preferably, such system is also suitable for the production of a DEF product, wherein the urea production unit comprises a divider for dividing a stream of urea liquid in at least two streams, and a unit for adding an additive to one of said streams downstream of said divider and upstream of a finishing section, and a unit for preparing a DEF product from the other stream.

Preferably, the treatment section comprises a venturi scrubber, more preferably an MMV scrubber.

Figure 1 shows a process scheme for a non-limiting example of a process and system according to the invention. Nitric acid 1 and ammonia gas 2 are reacted to provide aqueous ammonium nitrate solution 3 in an ammonium nitrate section A, thereby also yielding AN off-gas 4. Aqueous ammonium nitrate solution 3 is supplied to urea ammonium nitrate section B and off-gas 4 from ammonium nitrate section A is supplied to a finishing treatment section C. In urea production unit D urea is produced from carbon dioxide 5 and ammonia 6, yielding a urea liquid 9 (purified aqueous urea solution and/or concentrated urea liquid) which is supplied to finishing section E. Optionally, a part of the urea liquid 7 is supplied to urea ammonium nitrate section B. It is also possible that section B receives urea liquid from another urea production unit, instead or in combination with urea liquid 7. In section B, urea liquid is mixed with aqueous ammonium nitrate solution 3 to provide UAN stream 8. The system also comprises finishing section E wherein concentrated urea liquid 9 from urea production unit D is solidified. Finishing section E yields a solid urea product 10 and is for example a granulator or prilling tower. Finishing section E uses drying/cooling air 11 and provides ammonia-containing off-gas 12 that is supplied to finishing treatment section C adapted to subject off-gas 12 to treatment with an acidic scrubbing liquid 13 to give a cleaned off-gas 14. Optionally, spent scrubbing liquid 15 is recycled by supplying it to urea ammonium nitrate section B. Optionally, off-gas from urea production unit D is supplied to finishing treatment section C as a stream 16 and/or to ammonium nitrate section A as stream 17.

The term "fluid communication" includes any connection any connection between a first part or section of a plant and a second part or section of a plant via

which fluids, notably liquids, can flow from the first part of the plant to the second part of the plant. Such fluid communication is typically provided by piping systems, hoses, ducts, pumps, or other devices well-known to the skilled person for the transportation of fluids. The fluid communication can be direct fluid
5 communication, such as any of the foregoing without involving any further equipment other than the fluid transportation devices themselves. The fluid communication can also be indirect, wherein the fluid may be transported via piping system, hoses, ducts or pumps, and also including other equipment such as strippers or reactors. As used herein, the terms "inlet" and "outlet" can also be used
10 for intermediate streams.

The term "liquid stream" includes suspensions and dispersions and generally relates to a fluid stream comprising a continuous liquid phase. The term "gaseous stream" does not exclude the presence of entrained droplets and particles.

CLAIMS:

1. A process for the production of urea ammonium nitrate comprising
 - (a) subjecting ammonia and carbon dioxide to urea forming conditions in a high pressure urea synthesis section of a first urea production unit so as to obtain an aqueous urea solution;
 - 5 (b) purifying the aqueous urea solution in a recovery section of said first urea production unit to remove residual ammonium carbamate so as to form a purified aqueous urea solution;
 - (c) subjecting ammonia and nitric acid to ammonium nitrate forming conditions in an ammonium nitrate production unit so as to form an aqueous ammonium nitrate solution and a first ammonia-containing off-gas;
 - 10 (d) combining said aqueous ammonium nitrate solution
 - (i) with at least a part of the purified aqueous urea solution, and/or
 - (ii) with a concentrated urea liquidin a urea ammonium nitrate section so as to obtain an aqueous solution of urea ammonium nitrate; and
 - 15 (e) treating said first ammonia-containing off-gas resulting from the production of ammonium nitrate with an acidic scrubbing liquid in a treatment section, wherein either said first urea production unit comprises a finishing section that produces a second ammonia-containing off-gas and is adapted to solidify a urea liquid, and the treatment section is in fluid communication with a gas outlet of said finishing section for said second
 - 20 ammonia-containing off-gas of said finishing section, or the treatment section is in fluid communication with a gas outlet for a third ammonia-containing off-gas of a finishing section of a second urea production unit, wherein said finishing section of the second urea production unit produces said third ammonia-containing off-gas and is adapted to solidify a urea liquid.
- 25 2. The process of claim 1, wherein step (b) further comprises subjecting at least part of the purified aqueous urea solution to evaporation in an evaporation section so as to form the concentrated urea liquid of step (d)(ii).
3. The process of claim 1 or 2, comprising recycling all or part of a spent acidic scrubbing liquid utilized in the treatment section to the urea ammonium nitrate section.

4. The process of any one of claims 1 to 3, wherein all or part of the spent acidic scrubbing liquid utilized in the treatment section is combined with the aqueous solution of urea ammonium nitrate.
5. The process of any one of claims 1 to 4, wherein a fourth ammonia containing off-gas from the high pressure urea synthesis section and/or the recovery section of said first urea production unit is sent to a gas inlet of the ammonium nitrate production unit.
6. The process of any one of claims 1 to 5, wherein said first ammonia-containing off-gas resulting from the production of ammonium nitrate is combined with said second ammonia-containing off-gas of the finishing section to provide a combined gas stream.
- 10 7. The process of claim 6, wherein the combined gas stream is subjected to scrubbing to remove droplets and particles, and wherein the combined gas stream is subsequently subjected to scrubbing with the acidic scrubbing liquid in said treatment section.
8. The process of any one of claims 1 to 7, wherein the process is performed without condensing the first ammonia-containing off-gas resulting from the production of ammonium nitrate between the ammonium nitrate section and the treatment section.
- 15 9. The process of any one of claims 1 to 8, the process further comprising producing Calcium Ammonium Nitrate granules by
- (f) subjecting a part of the aqueous ammonium nitrate solution of (c) and a calcium salt stream, to a Calcium Ammonium Nitrate finishing unit so as to form Calcium Ammonium Nitrate-granules and a Calcium Ammonium Nitrate off-gas, said Calcium Ammonium Nitrate off-gas containing ammonia, ammonium nitrate and entrained Ca-containing particles; and
- 20 (g) feeding said Calcium Ammonium Nitrate off-gas to the treatment section wherein said treatment section is adapted to treat said Calcium Ammonium Nitrate off-gas with said acidic scrubbing liquid thereby forming a Ca-containing salt solution.
- 25 10. A process for the production of urea ammonium nitrate comprising
- (a) subjecting ammonia and carbon dioxide to urea forming conditions in a high pressure urea synthesis section of a first urea production unit so as to obtain an aqueous urea solution;
- (b) purifying the aqueous urea solution in a recovery section of said first urea production unit to remove residual ammonium carbamate so as to form a purified aqueous urea solution;
- 30 (c) dividing the purified aqueous urea solution stream of step (b) into three streams:

- (i) a first purified aqueous urea solution stream,
 - (ii) a second purified aqueous urea solution stream, and
 - (iii) a third purified aqueous urea solution stream;
- (d) adding an additive to the second purified aqueous urea solution stream downstream of
5 said dividing, wherein the additive is selected from the group consisting of anti-caking agents
and granulation aids, subjecting said second purified aqueous urea solution stream with said
additive to evaporation in an evaporation section, so as to form a concentrated urea liquid with
said additive, and subjecting at least part of said concentrated urea liquid with said additive to
solidification in a finishing section of the first urea production unit;
- 10 (e) diluting the third purified aqueous urea solution stream with water downstream to said
dividing;
- (f) subjecting ammonia and nitric acid to ammonium nitrate forming conditions in an
ammonium nitrate production unit so as to form an aqueous ammonium nitrate solution and a
first ammonia-containing off-gas;
- 15 (g) combining said aqueous ammonium nitrate solution and
- (i) the first purified aqueous urea solution stream, and/or
 - (ii) the concentrated urea liquid with the additive,
- in a urea ammonium nitrate section so as to obtain an aqueous solution of urea ammonium
nitrate;
- 20 (h) treating said first ammonia-containing off-gas resulting from the production of
ammonium nitrate with an acidic scrubbing liquid in a treatment section, wherein said first urea
production unit comprises the finishing section that produces a second ammonia-containing
off-gas and is adapted to solidify the concentrated urea liquid with the additive, and the treatment
section is in fluid communication with a gas outlet of said finishing section for said second
- 25 ammonia-containing off-gas of said finishing section; and
- (i) recycling all or part of a spent acidic scrubbing liquid utilized in the treatment section to the
urea ammonium nitrate section.
11. A plant for the production of at least urea and urea ammonium nitrate, comprising:
- 30 (a) a urea production unit comprising a high pressure urea synthesis section, a recovery
section, and a finishing section, wherein the urea production unit is configured for forming urea
from ammonia and carbon dioxide under urea forming conditions in the high pressure urea

synthesis section so as to obtain an aqueous urea solution, wherein the recovery section is configured for removal of residual ammonium carbamate so as to obtain a purified aqueous urea solution from the aqueous urea solution,

- (b) an ammonium nitrate section comprising an ammonium nitrate production unit for
5 producing ammonium nitrate in fluid communication with a source of nitric acid and a source of ammonia, having an outlet for an aqueous ammonium nitrate solution and an outlet for a first ammonia-containing off-gas,
wherein the finishing section of the urea production plant is adapted to solidify a first urea liquid and has a gas outlet for a second ammonia-containing off-gas,
- 10 (c) a urea ammonium nitrate section comprising a unit having an inlet in fluid connection with said outlet for the aqueous ammonium nitrate solution and an inlet for receiving a part of a second urea liquid, for combining said ammonium nitrate solution and said second urea liquid, and having an outlet for a urea ammonium nitrate solution, and
- (d) a treatment section is in fluid connection with said gas outlet for the second
15 ammonia-containing off-gas of said finishing section, adapted to subject said second ammonia-containing off-gas of the finishing section to treatment with an acidic scrubbing liquid, wherein said treatment section is in fluid communication with said outlet for the first ammonia-containing off-gas of said ammonium nitrate section.

12. The plant of claim 11, wherein said treatment section comprises an outlet for a spent
20 acidic scrubbing liquid utilized in the treatment section in fluid communication with a point downstream of said outlet for the aqueous ammonium nitrate solution.

13. The plant of claim 12, wherein the urea production unit comprises a divider for dividing a
purified aqueous urea solution stream in a first purified aqueous urea solution stream and a
second purified aqueous urea solution stream downstream to the recovery section of said urea
25 production unit, wherein the urea production unit further comprises a section for adding an additive to the first purified aqueous urea solution stream downstream of said divider and upstream of the finishing section, and wherein the urea production unit further comprises a section for preparing a Diesel Exhaust Fluid from the second purified aqueous urea solution stream downstream to said divider.

14. The plant of any one of claims 11 to 13, wherein said inlet for receiving a part of the second urea liquid of said urea ammonium nitrate section is in fluid connection with an outlet for the second urea liquid of the urea production unit,
wherein the high pressure urea synthesis section comprises a high pressure stripper and a
5 carbamate condenser and a urea reactor, or an integrated carbamate condenser and a urea reactor,
and wherein said ammonium nitrate section further comprises an inlet in fluid communication
with an outlet for a fourth ammonia-containing off-gas from one or more sections selected from
the group consisting of said high pressure urea synthesis section, the recovery section and an
evaporation section.
- 10 15. The plant of any one of claims 11 to 14, wherein said treatment section comprises a
venturi scrubber.
16. The plant of any one of claims 11 to 15, comprising a calcium ammonium nitrate
production section, said calcium ammonium nitrate production section comprising an inlet for
ammonium nitrate in fluid communication with an outlet for ammonium nitrate from the
15 ammonium nitrate section, wherein the calcium ammonium nitrate production section comprises
a granulation section having an outlet for calcium ammonium nitrate off-gas in fluid
communication with the treatment section.
17. A method of modifying an existing plant into the plant according to claim 11, the existing
plant comprising an ammonium nitrate section, a urea production unit, a treatment section, and a
20 urea ammonium nitrate section, wherein the urea production unit comprises a high pressure urea
synthesis section, a recovery section and an evaporation section, and a finishing section,
wherein the ammonium nitrate section is configured for reacting ammonia and nitric acid under
ammonium nitrate forming conditions and is in fluid communication with a source of nitric acid
and a source of ammonia and has an outlet for aqueous ammonium nitrate solution and an outlet
25 for a first ammonia-containing off-gas,
wherein the finishing section is adapted to solidify a first urea liquid, and wherein the finishing
section has a gas outlet for a second ammonia-containing off-gas,
wherein the treatment section has a first gas inlet in fluid communication with said gas outlet for
a second ammonia-containing off-gas of said finishing section, adapted to subject said second
30 ammonia-containing off-gas of the finishing section to treatment with an acidic scrubbing liquid,

wherein the urea ammonium nitrate section comprises a unit having an inlet in fluid connection with said outlet for aqueous ammonium nitrate solution and an inlet for receiving a second urea liquid, for combining said ammonium nitrate solution and said second urea liquid, and having an outlet for a urea ammonium nitrate solution,

- 5 the method comprising adding a connection for fluid communication between said outlet for a first ammonia-containing off-gas from said ammonium nitrate section and said treatment section.

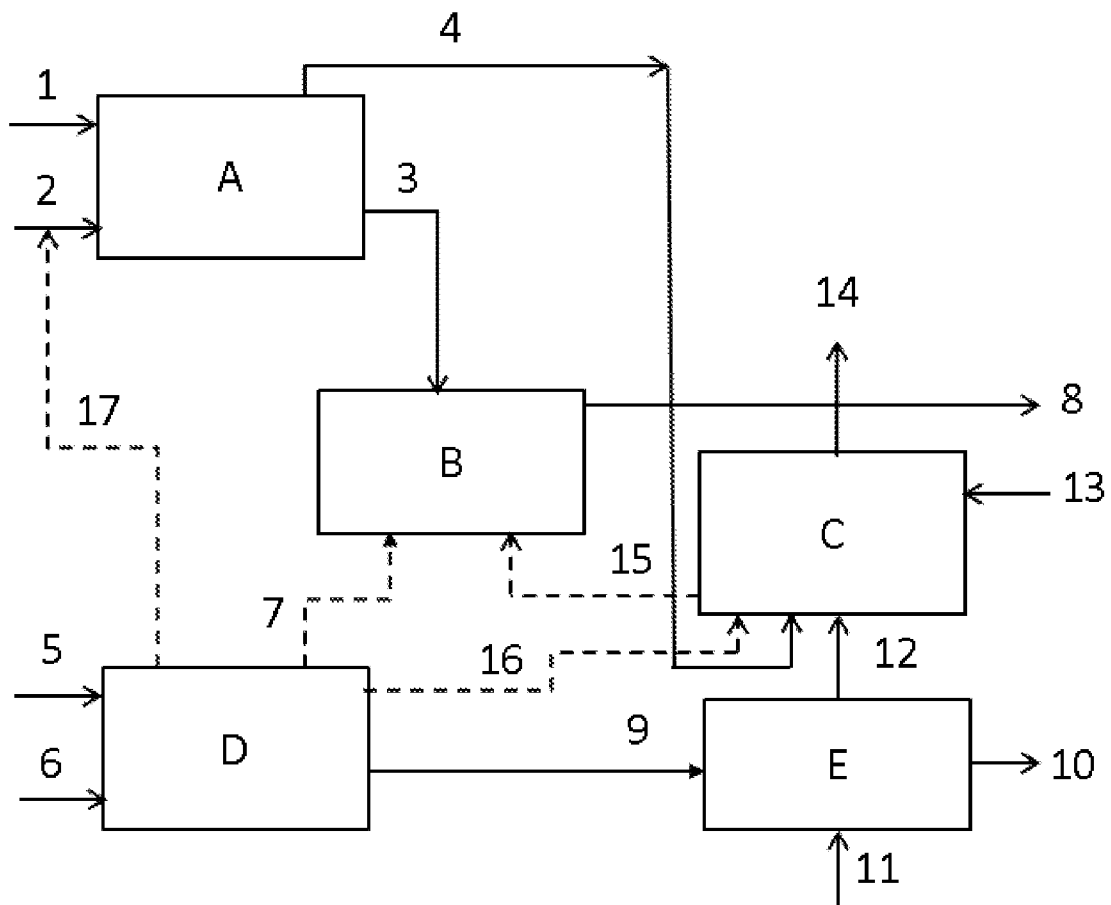

FIG. 1