

(19)  
(12)

(KR)  
(B1)

(51) 。 Int. Cl. <sup>7</sup>  
H02K 3/46  
H02K 1/12

(45)  
(11)  
(24)

2002 05 03  
10 - 0334221  
2002 04 12

(21) 10 - 2000 - 0069979  
(22) 2000 11 23

(65) 2001 - 0016218  
(43) 2001 03 05

(73)

가 569 - 21

II 505

(72)

370 101

(74)

:

(54)

, , , , ,  
,  
;  
, 가  
,  
;  
,  
;

, , , , , ,

1

2 (a) (b) 가

3 (a) (b)

4 (a) (b) (eddy current)

5

\* \*

20: 21:

22: 23:

24: ( ) 40:

45:

가 (cogging)

가 , 1 (a) (b) 가 1 (b)

가 ( )

1 (a) 가 ( ) (salient pole, 1 (a) 3 )

(半開)

가

가

가

[      ]

2 (a)

(24) , (20) (21), (22), (23)  
( )

(21) ( )  
(21) (20) (22)  
가

3 (a) (b)  
가

(brushless) 2  
, 3

가 가

4

(eddy current) (40)  
(45)  
4 (a) (21) 가 (N, S )  
가

(45) 4 (b)  
가 , 4 (b)

1/3

5

.  
 ,  
 , 가  
 , 가  
 , 가

(57)

1.

, ,  
 , ,  
 , ,

4.

1 ,

5.

4 ,

6.

1, 4, 5

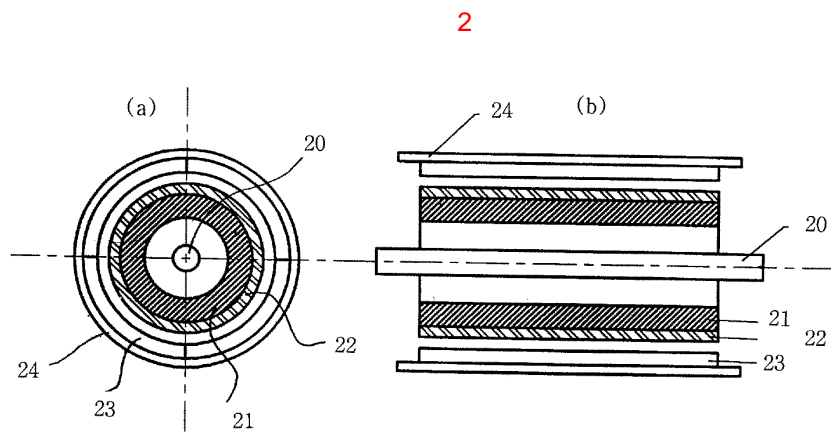
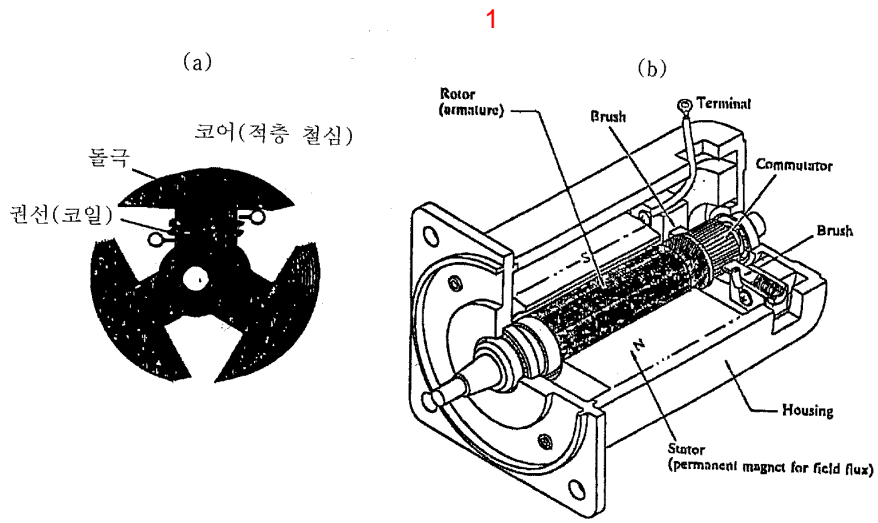

3

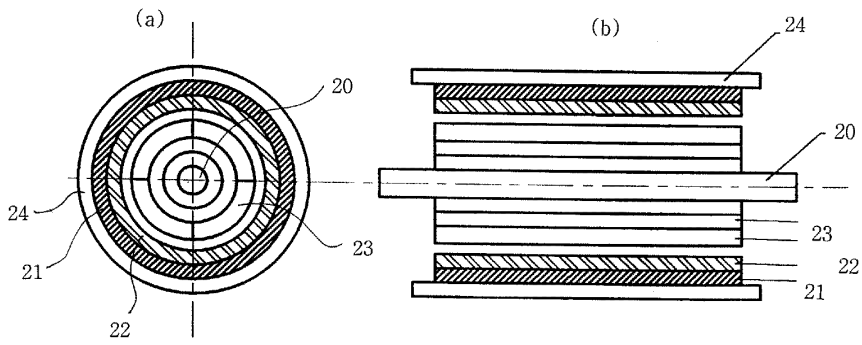

4

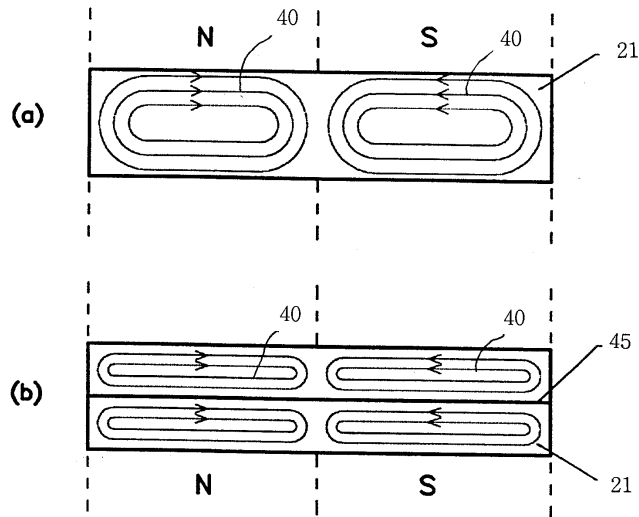

5

