



US 20130189900A1

(19) **United States**

(12) **Patent Application Publication**
Bloch Marco

(10) **Pub. No.: US 2013/0189900 A1**

(43) **Pub. Date: Jul. 25, 2013**

(54) **PIECE OF CLOTHING**

(52) **U.S. Cl.**

(76) Inventor: **Mauricio Bloch Marco**, Barcelona (ES)

CPC **A41C 3/00** (2013.01)

USPC **450/93**

(21) Appl. No.: **13/877,819**

(57) **ABSTRACT**

(22) PCT Filed: **Oct. 4, 2010**

(86) PCT No.: **PCT/ES2010/070640**

§ 371 (c)(1),

(2), (4) Date: **Apr. 4, 2013**

This piece of clothing comprises: a front portion (11) having two bags (12) longitudinally shaped and aligned to receive the wearer's bust, and extends in side portions (13) and a rear portion (14); said portions (11, 13, 14) being made of fabric of the same structure, and with a uniform horizontal flexibility for adaptation and action of the garment on the contour of the wearer's torso with a uniform pressure throughout. Said side and rear portions (13, 14) have a height or transverse dimension approximately equal to the height of the front portion (11).

Publication Classification

(51) **Int. Cl.**

A41C 3/00

(2006.01)

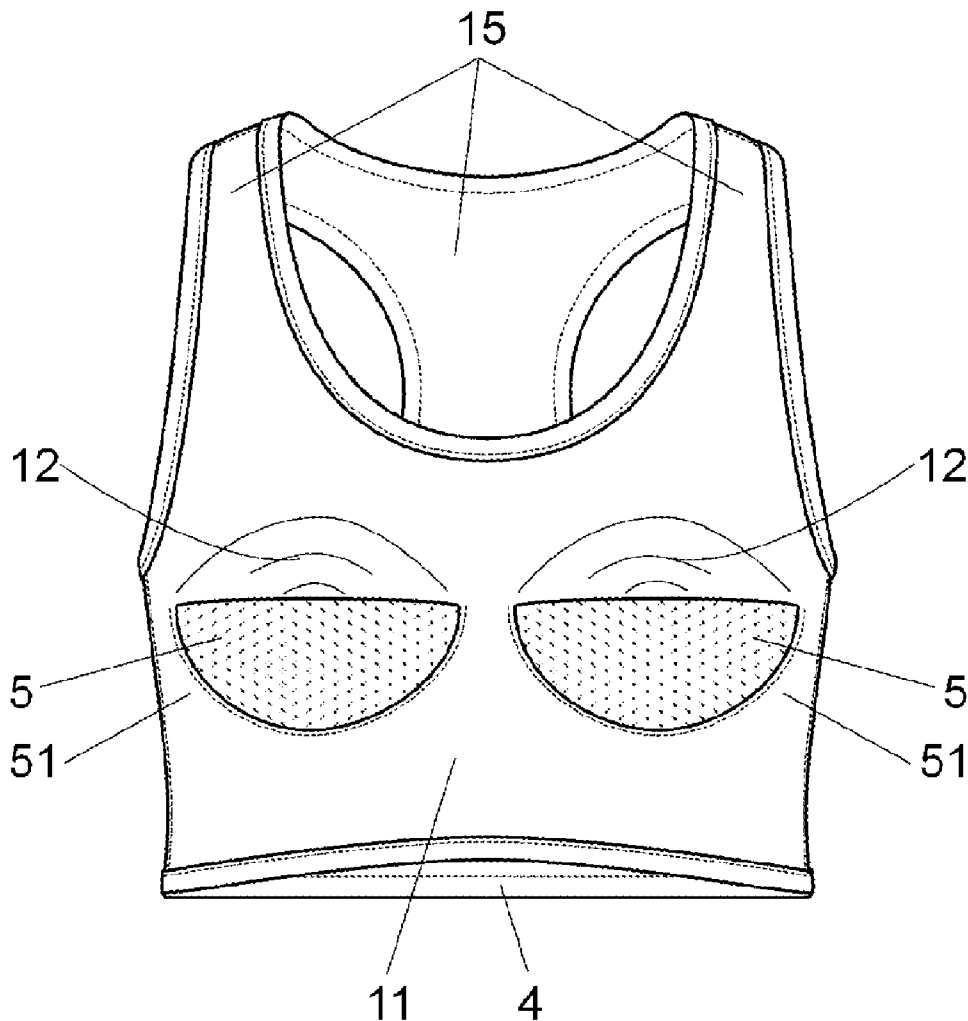

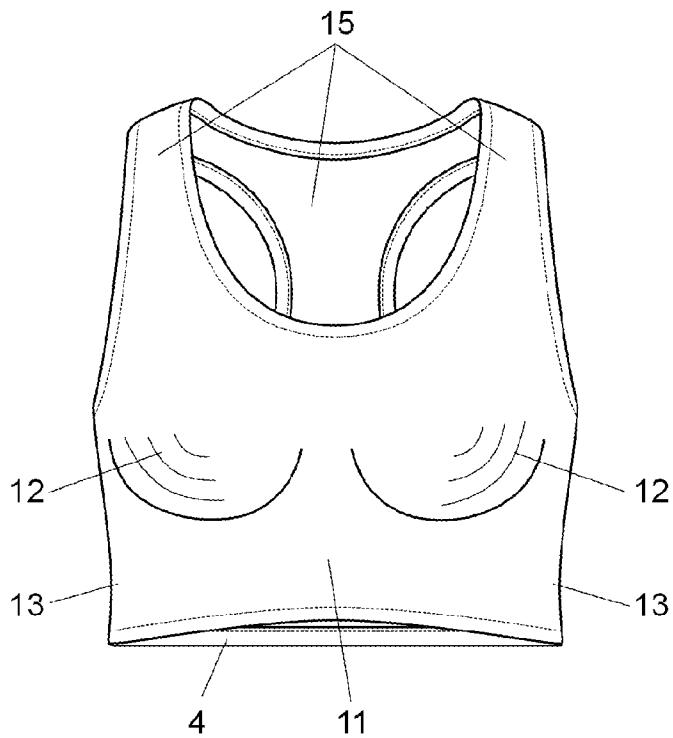

Fig. 1

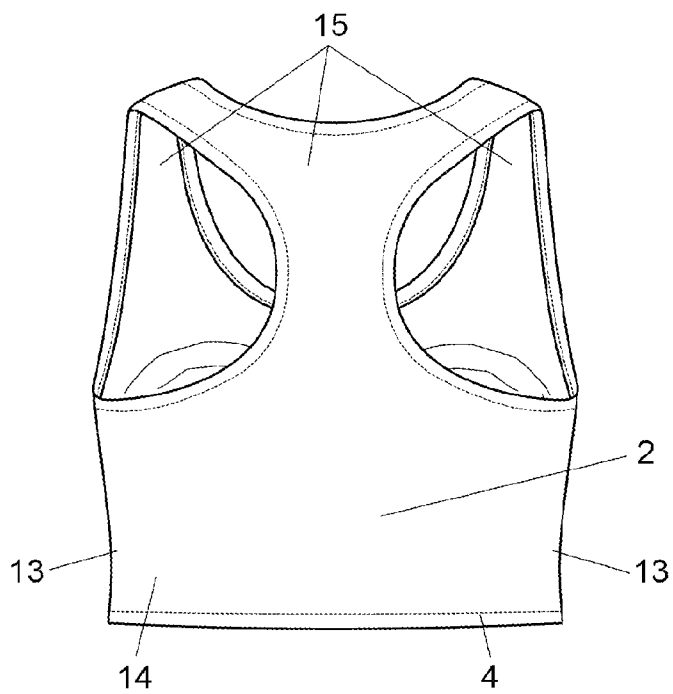

Fig. 2

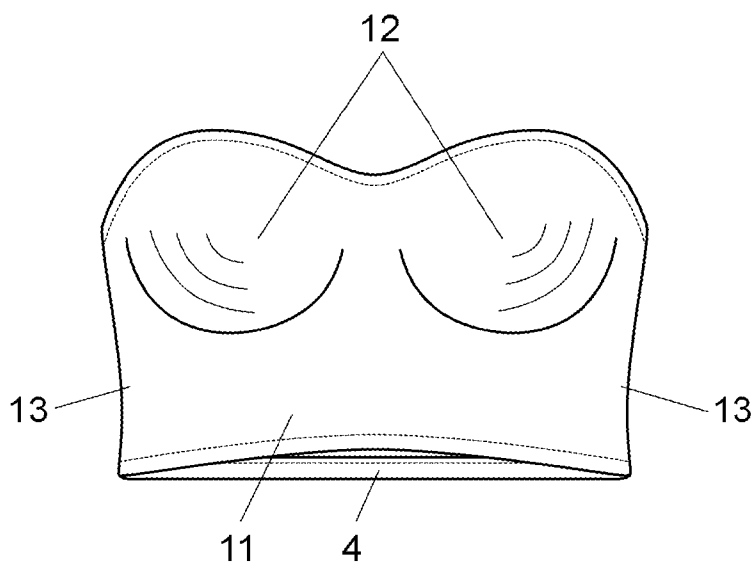

Fig. 3

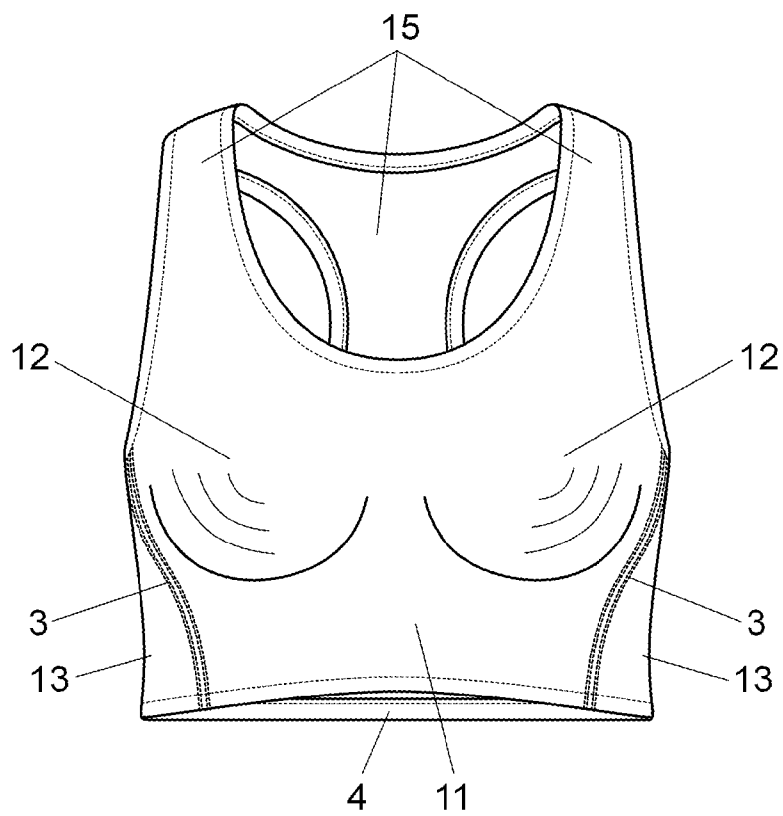

Fig. 4

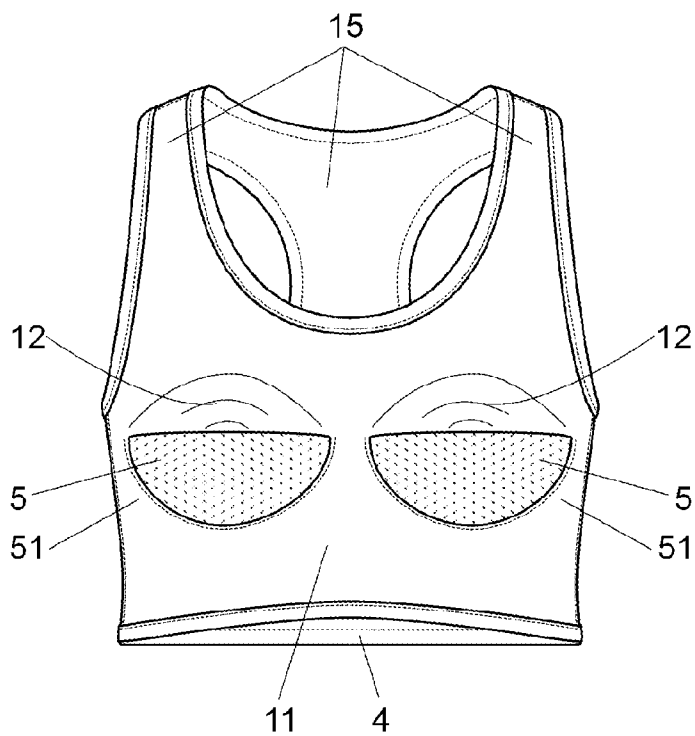

Fig. 5

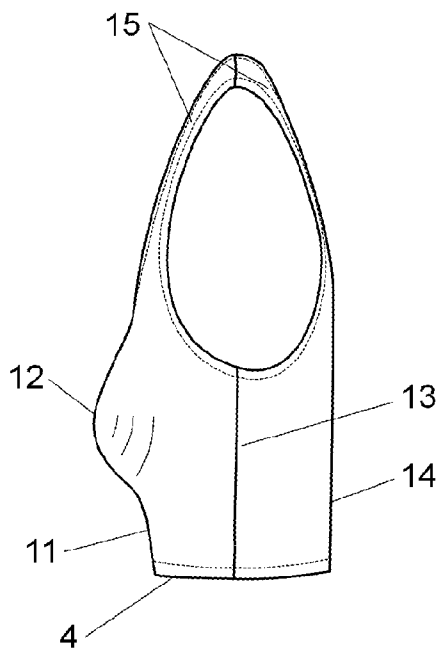

Fig. 6

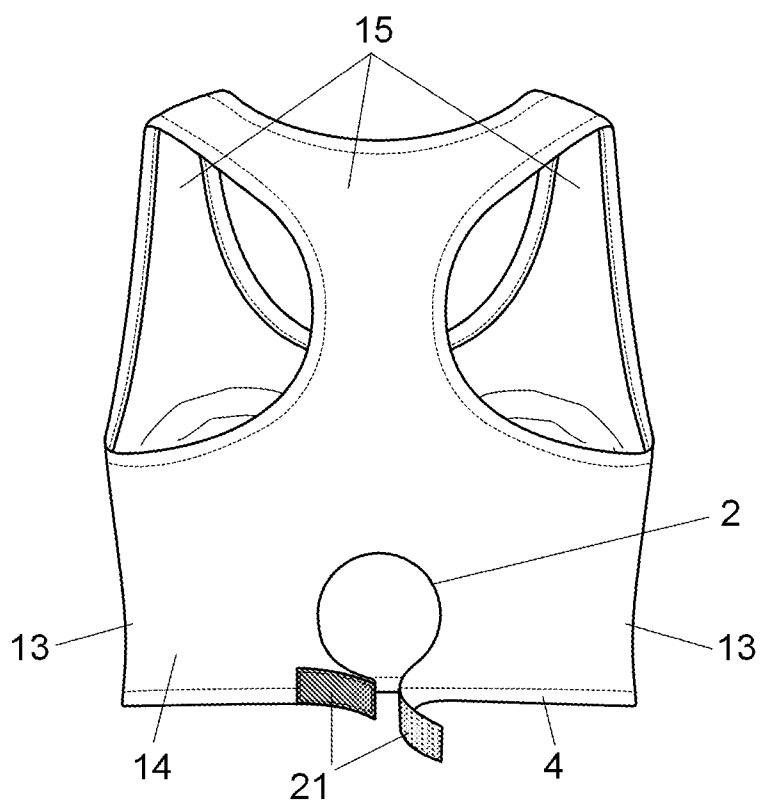

Fig. 7

PIECE OF CLOTHING

OBJECT OF THE INVENTION

[0001] The present invention relates to a piece of clothing which has features intended to carry out an effective support of the wearer's breasts, and provide a high wearing comfort.

FIELD OF APPLICATION OF THE INVENTION

[0002] This piece of clothing is applicable in the sector of clothing industry.

BACKGROUND OF THE INVENTION

[0003] It is common among the female population using underwear to support the bust, especially brassieres. These garments are designed with the primary objective to provide better esthetic appearance of the wearer to model the position and volume of the bust.

[0004] The bras are made of several pieces, conveniently attached together and made with materials of different characteristics, mainly in regard to their stiffness and elasticity.

[0005] Thus a conventional bra comprises a front structure that includes a pair of cups made of materials with limited or no elasticity, joined to each other by inelastic textile elements; usually including metal rings intended to be positioned below the breast, in order to provide stiffness to the cups.

[0006] This front structure is attached behind the torso with elastic bands whose ends are fixed through hooks or other similar closure means. Thus it is ensured that the bra is fitted tightly to the torso, and that the front structure is pushed by the action of elastic bands against the front of the torso.

[0007] Regardless of whether the brassiere has, or not, straps for the support on the shoulders, the features mentioned above and especially the combination of a front structure of limited or practically negligible flexibility, with elastic bands for the side support, determines that the use of these bra is uncomfortable for the wearer; on the one hand because the support tension is concentrated in elastic side bands with a reduced width, which causes that these elastic bands are nailed in the side areas of the torso and, on the other hand, because the tension transmitted by these elastic bands to a practically inelastic frontal structure determines that said frontal structure is also nailed in the front of the torso, especially in the lower area of the breast.

[0008] Due to this discomfort is common that wearers take off their bra when they get their home, or subsequently, when they are going to sleep, covering itself just with a T-shirt, top, or piece of clothing that has no specific characteristics for an effective support of the bust, which is also uncomfortable.

[0009] U.S. Pat. No. 5,944,579 "Non-constricting brassiere" by Marcia C. Fleischman describes a piece of clothing, more in particular a non-constricting brassiere that provides limited support. The brassiere comprises a single piece of fabric having a front panel and a continuous rear panel with shoulder straps connected from said panels. The front and rear panels are centrally connected at the front panel forming a vertical seam. Said seam has a gather that forms two separate areas for the breasts. The shoulder straps are a continuation of the material of the front and rear panels. Affixed to the lower portion of the front and rear panels is a continuous sewn hem. The bra provides a limited support so as to not adversely affect lymphatic circulation and to increase the wearer comfort. However, this bra still comprises an element limiting the inelastic constitution in the front part between the breasts,

formed by the vertical seam and the fabric gathered that is pulled or tightened by the rest of the front panel and rear panel. In addition, the reception areas of the breasts on each side of this seam do not have a suitable configuration which accepts the natural shape of said breasts.

[0010] Therefore, the problem that arises is the development of a garment, that in addition to perform a proper support of the bust, provides a high comfort of use, eliminating the inconvenience caused by conventional bras and which can be used both as an underwear as an outer garment, or swimsuit.

DESCRIPTION OF THE INVENTION

[0011] The piece of clothing, object of this invention has technical particularities intended to offer to the wearer great comfort of use without rigid elements or reinforcements that can be nailed to the skin, but providing an optimal level of support for long periods of time.

[0012] The piece of clothing is of the type comprising support means for the wearer's bust by its arrangement around the torso.

[0013] According to the invention said support means comprise a front portion having two longitudinally shaped and aligned bags for the placement of each breast, side portions and a rear portion which are applied to the contour of the torso, being said portions made of with fabric of the same structure, with properties of uniform horizontal flexibility preconizing the adaptation of the garment on the contour of the wearer's torso with a constant pressure at any point. Side and rear portions have a height or transverse dimension approximately equal to the height of the front portion.

[0014] This configuration allows that the garment is fitted to the contour of the wearer like a second skin following the movements of her body and providing through a distributed compression, a proper support of the bust. Since the piece of clothing lacks of rigid elements, seams between elastics fabrics and inelastic fabrics, and areas where the width of the fabric is weakened or suspension parts, does not nail in the torso, such as occurs with a conventional brassiere, and therefore does not create areas of friction, pressure or punching.

[0015] In a preferred embodiment, the front, side and rear portions, made of one or more pieces of fabric with the same structure, give to the garment a tubular configuration, which exerts a nearly uniform pressure throughout its length on the wearer's body and provides a high comfort of use of the garment.

[0016] In one embodiment of the invention the garment comprises in at least one area of its perimeter an opening that extends vertically from the lower edge of the garment and presents on the opposite edges complementary closure means.

[0017] The release of these closure means allows the partial enlargement of the garment during its placement or removal, by passing appropriately inside the same the head and arms, or else the hip.

[0018] In one embodiment, the front portion and the rear portion extend through its upper edge in support wide bands on the shoulders, adopting the garment a configuration as a "top" with the added function of supporting for the bust.

[0019] In this embodiment it is provided for the incorporation in the garment of means for adjusting the length of said upper support bands, and thus, regulating the height of the bust.

[0020] In a specific example, the piece of clothing has oblique seams at outer sides of the bags which define centering means for the breast, improving thus the aesthetics of the silhouette.

[0021] In an embodiment, the garment comprises a hem, with or without elastic, at its lower edge intended to prevent rolling during its use, ensuring thus that the fabric is fully fitted on the wearer's torso.

[0022] In an alternative embodiment, the garment comprises partial filling elements made of a foamy and/or elastic material, fixed on the inside of the bags so that it is achieved an enhanced effect of the wearer's bust, increasing the volume effect, known as push-up effect.

[0023] These filling elements, with concave shape, and approximately semi-circular elevation, are fixed preferably by a seam.

[0024] It is not ruled out the adaptation of the garment, in regard to the size of the bags and the filling, to ensure an appropriate use by those male users who wish to increase the volume of the pectoral muscles in order to get an athletic and muscular appearance.

DESCRIPTION OF THE FIGURES

[0025] To complement the description being made and in order to facilitate understanding of the features of the invention is attached to this specification a set of drawings in which, with illustrative and non-limiting character, the following has been represented:

[0026] FIG. 1 shows an elevation view of a piece of clothing provided with the supporting bands or straps to the shoulders.

[0027] FIG. 2 shows a rear elevation view of the garment of the previous figure.

[0028] FIG. 3 shows an elevation view of the piece of clothing made of a single tubular piece of continuous fabric.

[0029] FIG. 4 shows an elevation view of a piece of clothing with centering seams of the bust.

[0030] FIG. 5 shows an elevation view of the garment turned inside out, in which it can see the inside of the front area and the filling elements fixed in the bags.

[0031] FIG. 6 shows a profile view of the garment of the previous figure.

[0032] FIG. 7 shows a rear elevation view of an alternative embodiment of the garment provided with a lower opening in "V" with complementary closure means at the opposite edges.

PREFERRED EMBODIMENT OF THE INVENTION

[0033] As can be seen in the referenced figures, the piece of clothing comprises support means for the bust constituted by: a front portion (11) having two bags (12) longitudinally shaped and aligned made for the accommodation of the breasts, side portions (13) and a rear portion (14); said portions (11, 13, 14) being made of fabric of the same structure, with properties of uniform horizontal flexibility.

[0034] The garment has a tubular configuration defined by one or more pieces of fabric with the same structure, conveniently attached.

[0035] As can be seen in the accompanying figures the side and rear portions (13, 14) have a height or transverse dimension approximately equal to the height of the front portion (11).

[0036] In the embodiment shown in FIG. 7, the garment has at the rear portion (14) an opening (2) which extends from the lower edge of the garment and having in the opposite edges complementary closure means (21) mutually attachable for the closure of this opening (2) in an operative position.

[0037] The release or opening of said complementary closure means provides additional enlargement of the garment in order to facilitate its placement or removal by the wearer.

[0038] In the embodiment shown in FIGS. 1 and 2, the garment has the front and rear portions (11, 14) extended along its upper edge in wide bands (15) for its support on the wearer's shoulders.

[0039] In said embodiment the garment comprises diagonal seams (3) at the outer sides of the bags (12), whose purpose is to define centering means for the bust and improve the silhouette.

[0040] In the examples shown, the garment comprises a hem (4) at the lower edge to prevent the garment from rolling on itself during its normal use and forming a perimeter thickening that might become uncomfortable for the wearer's since creates a higher pressure area.

[0041] In the example shown in FIG. 5, the garment comprises, inside the bags, filling elements (5), made of foamy and/or elastic material, fixed by means of semicircular seams (51) on the inside of the bags (12).

[0042] With the features mentioned, this garment may further incorporate laces, embroideries, prints or any other finishes intended to its embellishment.

[0043] Having sufficiently described the nature of the invention as well as a preferred embodiment, it is stated for pertinent purposes that the materials, shape, size and arrangement of elements described may be modified, provided that this does not alter the essential features of the invention claimed below.

1. Piece of clothing, of the type comprising support means for supporting the wearer's bust or breasts through its arrangement around the contour of the torso, said support means comprise a front portion having two bags longitudinally shaped and aligned to receive the wearer's bust, side portions and a rear portion, applied on the contour of the torso, said portions being made of fabric of the same structure, and with a uniform horizontal flexibility for adaptation and action of the garment on the contour of the wearer's torso with a uniform pressure throughout; and in that the side and rear portions have a height or transverse dimension approximately equal to the height of the front portion; and in that comprises in the outer sides of the bags, oblique seams having means for centering the wearer's bust.

2. The garment, according to the claim 1, wherein the front, side, and rear portions made of one or several pieces of fabric with the same structure give to the garment a tubular configuration.

3. The garment, according to claim 1 comprising at least an opening which extends vertically from the lower edge of the garment and having in its opposite edges complementary closure means, whose release allows additional enlargement of the garment during its placement or removal in relation to the wearer's torso.

4. The garment, according to claim 1 wherein the front portion and the rear portion extend along its upper edge in wide bands for its support on the wearer's shoulders.

5. The garment, according claim 1 wherein the garment comprises at its lower and/or upper edge a hem or another equivalent mean to prevent the rolling on itself during its use.

6. The garment, according to claim 1 comprising partial filling elements of the bags, made of a foamy and/or elastic material, and fixed into the inside of said bags.

* * * * *