

**(12) PATENT**  
**(19) AUSTRALIAN PATENT OFFICE**

**(11) Application No. AU 199670262 B2**  
**(10) Patent No. 703687**

(54) Title  
**Refrigerant evaporator, improved for uniform temperature of air blown out therefrom**

(51)<sup>6</sup> International Patent Classification(s)  
**F 25B 039/02 F 28F 013/06**  
**F 25B 041/00**

(21) Application No: **199670262** (22) Application Date: **1996 .10 .17**

(30) Priority Data

(31) Number	(32) Date	(33) Country
<b>7-273221</b>	<b>1995 .10 .20</b>	<b>JP</b>
<b>8-182307</b>	<b>1996 .07 .11</b>	<b>JP</b>

(43) Publication Date : **1997 .04 .24**

(43) Publication Journal Date : **1997 .04 .24**

(44) Accepted Journal Date : **1999 .04 .01**

(71) Applicant(s)  
**Denso Corporation**

(72) Inventor(s)  
**Eiichi Torigoe; Masahiro Shimoya**

(74) Agent/Attorney  
**GRIFFITH HACK,GPO Box 3125,BRISBANE QLD 4001**



AU9670262

(12) PATENT ABSTRACT (11) Document No. AU-A-70262/96  
(19) AUSTRALIAN PATENT OFFICE

(54) Title  
REFRIGERANT EVAPORATOR, IMPROVED FOR UNIFORM TEMPERATURE OF AIR BLOWN OUT THEREFROM

International Patent Classification(s)  
(51)<sup>6</sup> F25B 039/02 F25B 041/00 F28F 013/06

(21) Application No. : 70262/96 (22) Application Date : 17/10/96

(30) Priority Data

(31) Number	(32) Date	(33) Country
7-273221	20/10/95	JP JAPAN
8-182307	11/07/96	JP JAPAN

(43) Publication Date : 24/04/97

(71) Applicant(s)  
DENSO CORPORATION

(72) Inventor(s)  
EIICHI TORIGOE; MASAHIRO SHIMOYA

(74) Attorney or Agent  
GRIFFITH HACK, GPO Box 4164, SYDNEY NSW 2001

(57) According to the present invention, plural downstream side evaporation passages in a downstream side heat exchanging unit are divided into two groups substantially at the middle of the width by a separator, plural upstream side evaporation passages in an upstream side heat exchanging unit are divided into two groups substantially at the middle of the width by a separator, and a downstream side lower tank and an upstream side upper tank are communicated by a communication passage so that inefficient heat exchanging areas of the downstream side heat exchanging unit and the upstream side heat exchanging unit disposed one after the other with respect to the flowing direction of air may not overlap with each other. Since the inefficient heat exchanging area in the downstream side heat exchanging unit and the inefficient area in the upstream side heat exchanging unit are disposed symmetrically with each other, the temperature distribution of air blown out from the

(11) 70262/96

-2-

refrigerant evaporator is prevented from being biased, and air having a uniform temperature distribution can be produced by the refrigerant evaporator.

**ABSTRACT OF THE DISCLOSURE**

According to the present invention, plural downstream side evaporation passages in a downstream side heat exchanging unit are divided into two groups substantially at the middle of the width by a separator, plural upstream side evaporation passages in an upstream side heat exchanging unit are divided into two groups substantially at the middle of the width by a separator, and a downstream side lower tank and an upstream side upper tank are communicated by a communication passage so that inefficient heat exchanging areas of the downstream side heat exchanging unit and the upstream side heat exchanging unit disposed one after the other with respect to the flowing direction of air may not overlap with each other. Since the inefficient heat exchanging area in the downstream side heat exchanging unit and the inefficient area in the upstream side heat exchanging unit are disposed symmetrically with each other, the temperature distribution of air blown out from the refrigerant evaporator is prevented from being biased, and air having a uniform temperature distribution can be produced by the refrigerant evaporator.



AUSTRALIA  
Patents Act 1990

**ORIGINAL  
COMPLETE SPECIFICATION  
STANDARD PATENT**



Invention Title: REFRIGERANT EVAPORATOR, IMPROVED FOR  
UNIFORM TEMPERATURE OF AIR BLOWN OUT  
THEREFROM

The following statement is a full description of this invention, including  
the best method of performing it known to us:

GH REF: P14339-BF:CAS:RK

**REFRIGERANT EVAPORATOR, IMPROVED FOR  
UNIFORM TEMPERATURE OF AIR BLOWN OUT THEREFROM**

**BACKGROUND OF THE INVENTION**

5    **1. Field of the Invention:**

The present invention relates to a refrigerant evaporator which evaporates and gasifies the refrigerant by performing heat exchange between a gas-liquid two-phase refrigerant received from a pressure reducing means and air.

10    **2. Description of Related Art:**

Recently, there have been high demands for downsizing a refrigerant evaporator, i.e., one of the components for forming the refrigeration cycle for an automotive air conditioner, by reducing the depth, i.e., a dimension in the flowing direction of air in a unit case, for increasing the size of the refrigerant evaporator by increasing the width and the height, i.e., dimensions in directions perpendicular to the airflow direction in the unit case, and for leveling the distribution of the temperature of air blown out from the refrigerant evaporator. There is also a demand for extending a refrigerant inlet and a refrigerant outlet in the same direction from one side surface of the refrigerant evaporator in view of the relation of the installation of the other components for forming the refrigeration cycle with the refrigerant evaporator.

15  
20  
25    Referring to FIG. 10, a refrigerant evaporator 100 proposed in JP-U-7-12778 has a downstream side heat exchanging unit 104 constructed by laminating in the direction of width

plural refrigerant passage units each having an upper tank 101,  
a refrigerant evaporation passage 102 and a lower tank 103, and  
an upstream side heat exchanging unit 108 constructed by  
laminating plural refrigerant passage units each having an upper  
5 tank 105, refrigerant evaporation passages 106 and a lower tank  
107. The downstream side heat exchanging unit 104 and the  
upstream side heat exchanging unit 108 are disposed one after the  
other in the airflow direction, and a refrigerant inlet 109 and  
a refrigerant outlet 110 are extended in the same direction from  
10 one side of the refrigerant evaporator 100.

In this refrigerant evaporator 100, the right end of the  
upper tank 101 and the right end of the upper tank 105 are  
communicated by a communication passage 111, the refrigerant  
inlet is formed in the left end of the upper tank 101, and the  
15 refrigerant outlet is formed in the left end of the upper tank  
105. The upper tanks 101 and 105 are provided substantially in  
middle portions with partition members 112 and 113 for dividing  
the refrigerant evaporation passages 102 and 106 into two  
sections, respectively, so that the refrigerant flows through the  
two sections of each of the refrigerant evaporation passages as  
20 shown in FIG. 10.

20  
25

The refrigerant having flowed from the refrigerant inlet  
109 into the left section of the upper tank 101 flows through the  
left section of the refrigerant evaporation passage 102, the  
lower tank 103, the right section of the refrigerant evaporation  
25 passage 102, the right section of the upper tank 101, the  
communication passage 111, the right section of the upper tank

105 of the upstream side heat exchanging unit 108, the right section of the refrigerant evaporation passage 106, the lower tank 107, the left section of the refrigerant evaporation passage 109 and the left section of the upper tank 105 in that order and  
5 flows outside through the refrigerant outlet 110.

In this refrigerant evaporator 100, the refrigerant flowing in one direction through the upper tanks 101 and 105 is distributed to the refrigerant evaporation passages 102 and 106. Therefore, most part of the refrigerant may flow by gravity more  
10 easily into portions of the refrigerant evaporation passages connected to portions of the upper tanks 101 and 105 on the upstream side than portions on the downstream side. Since the refrigerant flows upward from the lower tanks 103 and 107 into the refrigerant evaporation passages 102 and 106 after the  
15 refrigerant has reached portions of the lower tanks 103 and 107 on the downstream side, the refrigerant may flow easily into portions of the refrigerant evaporation passages 102 and 106 connected to the downstream side of the lower tanks 103 and 107.

20

25

30

35

When the refrigerant thus flows in the refrigerant evaporator 100 shown in FIG. 10, the direction of flow of the refrigerant in the refrigerant evaporation passage 102 of the downstream side heat exchanger 104 and that of flow of the refrigerant in the refrigerant evaporation passage 106 of the upstream side heat exchanger 108 facing the refrigerant evaporation passage 102 are opposite to each other. Consequently, the distribution of flow the refrigerant in the upstream side heat exchanger 108 and that of flow of the



refrigerant in the downstream side heat exchanger 104 coincide substantially with each other and hence there is a problem that the distribution of temperature of air blown out from the refrigerant evaporator may be biased.

5

**SUMMARY OF THE INVENTION**

Accordingly it would be advantageous if at least a preferred embodiment in accordance with the present invention could suppress the biased distribution of the temperature of air blown out from the refrigerant evaporator due to the uneven flow of the refrigerant into the refrigerant evaporation passages.

According to the present invention there is provided a refrigerant evaporator for evaporating refrigerant flowing therein to cool outside air flowing therethrough said evaporator comprising:



15 first evaporation passage means for defining plural first evaporation passages through which the refrigerant flows, said plural first evaporation passages being formed substantially vertically and arranged substantially in parallel with each other in a direction substantially perpendicular to the flowing direction of said outside air;



25 a first tank portion connected to each of upper ends and lower ends of said plural first evaporation passages, said first tank portion extending in a direction crossing said first evaporation passages;



30 second evaporation passage means for defining plural second evaporation passages through which the refrigerant flows, said plural second evaporation passage being formed substantially vertically and arranged substantially in parallel with each other in a direction substantially perpendicular to the flowing direction of said outside air, said plural second evaporation passages being disposed adjacent to said first evaporation passages at a downstream side of the evaporator with respect to the flow direction of said outside air;

35 a second tank portion connected to each of upper ends and lower ends of said plural second evaporation



4339BF/703

passages, and said second tank portion extending in a direction crossing said second evaporation passages; and

communication means for defining a communication passage for communicating between said plural first evaporation passages and said second evaporation passage, wherein:

the refrigerant flows in the same vertical direction at least in portions where said plural first evaporation passages are aligned in the flow direction of the outside air and said plural second evaporation passages are aligned in the flow direction of the outside air; and

said first tank portion has a first refrigerant distributing portion through which refrigerant is distributed into said first evaporation passages, and a first refrigerant joining portion into which refrigerant having passed through said first evaporation passages flows;

said second tank portion has a second refrigerant distributing portion through which refrigerant is distributed into said second evaporation passages, and a second refrigerant joining portion into which refrigerant having passed through said second evaporation passages flows;

said first refrigerant distributing portion and said second refrigerant distributing portion are disposed in such a manner that the flow direction of refrigerant in said first refrigerant distributing portion is opposite to that in said second refrigerant distributing portion; and

said first refrigerant joining portion and said second refrigerant joining portion are disposed in such a manner that the flow direction of refrigerant in said first refrigerant joining portion is opposite to that in said second refrigerant joining portion.

It is preferred that the evaporation passage groups of the first evaporation passages where the liquid refrigerant flows easily and the evaporation passage groups of the second evaporation passages where the



S:14339BF/703

liquid refrigerant does not flow easily are symmetrical with each other. Consequently by not overlapping the first evaporation passages with the second evaporation passages with respect to the flowing direction of the outside air, in which air is not cooled efficiently, the bias of distribution of the temperature of air passing the outside of the first evaporation passages and the outside of the second evaporation passages can be suppressed.

10 **BRIEF DESCRIPTION OF THE DRAWINGS**

A preferred embodiment of the present invention will now be described by way of example only with reference to the accompanying drawings in which:

15 Figure 1 is a perspective view of a left-right two-sectioned refrigerant evaporator in a first embodiment;

Figure 2 is a diagrammatic view for explaining the flowing direction of a refrigerant in the refrigerant evaporator in the



first embodiment;

FIG. 3 is a perspective view of a pair of pressed plates employed in the first embodiment;

FIG. 4 is a diagrammatic view showing the state of the  
5 refrigerant in right evaporation passage groups of a first and a second heat exchanging unit in the first embodiment;

FIG. 5 is a diagrammatic view showing the state of the refrigerant in the left evaporation passage groups of the first and the second heat exchanging unit in the first embodiment;

10 FIG. 6 is a perspective view of a left-right two-sectioned refrigerant evaporator in a second embodiment;

FIG. 7 is a diagrammatic view for explaining the flowing direction of a refrigerant in a three-sectioned refrigerant evaporator in a third embodiment;

15 FIG. 8 is a diagrammatic view for explaining the flowing direction of a refrigerant in a four-sectioned refrigerant evaporator in a fourth embodiment;

FIG. 9 is a diagrammatic view of assistance in explaining the flowing direction of a refrigerant in a one-way type  
20 refrigerant evaporator in a fifth embodiment;

FIG. 10 is a diagrammatic view for explaining the flowing direction of a refrigerant in a conventional two-sectioned refrigerant evaporator;

FIG. 11 is a perspective view of a modification of the  
25 refrigerant evaporator;

FIG. 12 is a perspective view of another modification of the refrigerant evaporator;

FIG. 13 is a side view of the modification;  
FIG. 14 is another side view of the modification; and  
FIG. 15 is a perspective view of another modification of  
the refrigerant evaporator.

5

#### DETAILED DESCRIPTION OF THE PREFERRED EMBODIMENTS

A first embodiment of the present invention will be described.

FIG. 1 is a perspective view of a left-right  
10 two-sectioned refrigerant evaporator in a first embodiment according to the present invention, FIG. 2 is a diagrammatic view showing the flow of a refrigerant in the refrigerant evaporator of FIG. 1, and FIG. 3 is a perspective view of a pair of plates.

The left-right two-sectioned refrigerant evaporator  
15 (hereinafter referred to simply as "refrigerant evaporator") 1 is a laminated heat exchanger functioning as an evaporator for forming the refrigeration cycle of an automotive air conditioner. The refrigerant evaporator 1 cools air by heat exchanging between the air passing therethrough and a refrigerant flowing therein so as to vaporize and gasify the refrigerant. The refrigerant evaporator 1 is installed perpendicularly to the airflow direction in an air duct (unit case) of air conditioner, for example, in a front section of the passenger compartment of a vehicle. The refrigerant evaporator 1 has a downstream side heat  
20 exchanging unit (a heat exchanger body, or an evaporator body) 2 on the downwind side (downstream side) with respect to the airflow direction, and a front heat exchanging unit (a heat  
25

exchanger or an evaporator) 3 disposed on the upwind side (upstream side, or front side) with respect to the flowing direction of air.

Each of the downstream side heat exchanging unit 2 and the upstream side heat exchanging unit 3 includes plural pairs of pressed plates 4 laminated in the width direction perpendicular to the airflow direction (horizontal direction), plural corrugated fin plates 5 disposed between the adjacent pressed plates for improving the efficiency of heat exchange (heat transfer efficiency) between the refrigerant and air, an end plate 6, and a side plate 7. The end plate 6 and the side plate 7 reinforce the downstream side heat exchanging unit 2 and the upstream side heat exchanging unit 3. Those components are integrally joined together by brazing in a furnace.

The pair of pressed plates 4 will be described in detail with reference to FIGS. 1 to 3. The pair of pressed plates 4 are formed by pressing thin aluminum alloy plates having a high thermal conductivity. The pair of pressed plates 4 are joined together by brazing. Each pressed plate 4 has a substantially rectangular flange 11, and a partition rib 14 for dividing a space surrounded by the flange 11 into two elongated (I-shaped) recesses 12 and 13.

The pair of pressed plates 4 define a downstream side passage tube 20 on the downstream air side with respect to the airflow direction, and an upstream side passage tube 30 on the upstream air side with respect to the airflow direction. The downstream side passage tube 20 has a second evaporation passage

21 formed by the elongated recesses 12 of the pair of pressed plates 4. The front passage tube 30 has a first evaporation passage 31 formed by the elongated recesses 13 of the pair of pressed plates 4.

5           The second evaporation passage 21 is formed on the upstream air side with respect to the flowing direction of the refrigerant relative to the first evaporation passage 31 to evaporate and gasify the refrigerant by performing the heat exchange between the liquid-dominant gas-liquid two-phase  
10 refrigerant flowing through the second evaporation passage 21 and air. The opposite surfaces of the pair of pressed plates 4 forming the second evaporation passage 21 may be provided with plural ribs to spread the refrigerant in a width direction of the passage and with inner fins to promote the heat transfer.

15           The first evaporation passage 31 is formed on the downstream side with respect to the flowing direction of the refrigerant relative to the second evaporation passage 21. The gas-dominant gas-liquid two-phase refrigerant flowing through the first evaporation passage 31 absorbs heat from air and evaporates. The opposite surfaces of the pair of pressed plates  
20 4 forming the first evaporation passage 31 may be provided with plural ribs (protrusion) for spreading the refrigerant widthwise or inner fins for promoting heat transfer.

25           A second upper tank portion 22 is formed at the upper end of the downstream side passage tube 20, i.e., the upper side of the second evaporation passage 21, and a second lower tank portion 23 is formed at the lower end of the downstream side

passage tube 20, i.e., the lower side of the second evaporation passage 21. A first upper tank portion 32 is formed at the upper end of the front passage tube 30, i.e., the upper side of the first evaporation passage 31, and a first lower tank portion 33 is formed at the lower end of the front passage tube 30, i.e., the lower side of the first evaporation passage 31.

Elliptic communication holes 221 and 231 are formed in the second upper tank portion 22 and the second lower tank portion 23, respectively. The interiors of the adjacent downstream side passages 20 communicate with each other by the holes 221 and 231. Elliptic holes 321 and 331 are formed in the first upper tank portion 32 and the first lower tank portion 33, respectively. The interiors of the adjacent upstream side passage tube 30 communicate with each other by the holes 321 and 331. Thus, the upper half and the lower half of the pair of pressed plates 4 are symmetric with respect to a horizontal center axis, and the upstream side half and the downstream side half of the pair of pressed plates 4 are symmetric with respect to a vertical center line. A second upper tank 24 is formed at the upper end of the downstream side heat exchanging unit 2 by communicating plural second upper tank portions 22 in the direction of laminating the downstream side passage tubes 20, as shown in FIG. 1. A second lower tank 25 is formed at the lower end of the downstream side heat exchanging unit 2 by communicating plural second lower tank portions 23 in the direction of laminating the downstream side passage tubes 20, as shown in FIG. 1.



A separator 27 is at the substantially middle of the second lower tank 25 with respect to the width direction (the laminating) to divide the plural second lower tank portions 23 into two lower tank groups 23a and 23b (FIG. 2). The separator 27 is formed by not providing the communication holes 231 of the second lower tank portions 23 of the two downstream side passage tubes 20 substantially at the middle of the second lower tank 25 by partition walls. The separator serves also as a downstream side evaporation passage dividing means for dividing the plural second evaporation passages 21 into two groups (an even number of groups), i.e., a first evaporation passage group 21a and a second evaporation passage group 21b (FIG. 2).

As shown in FIGS. 1 and 2, a first upper tank 34 is formed at the upper end of the upstream side heat exchanging unit 3 by communicating the first upper tank portions 32 in the direction of laminating the upstream side passage tubes 30. As shown in FIG. 2, a second lower tank 35 is formed at the upstream side heat exchanging unit 3 by communicating the first lower tank portions 33 in the direction of laminating the upstream side passage tubes 30.

20  
25

A separator 36 is formed substantially at the middle of the first upper tank 34 with respect to the laminating direction to divide the plural first upper tank portions 32 into two upper tank portion groups 32a and 32b as shown in FIG. 2. The separator 36 divides the first upper tank 34 into two sections at a position substantially corresponding to the second evaporation passage 21 of the downstream side heat exchanging

unit 2. The separator 36 is formed by not providing the holes 321 of the first upper tank portions 32 of the two upstream side passage tubes 30 substantially at the middle by partition walls. The separator 36 serves also as an upstream side evaporation passage dividing means for dividing the plural first evaporation passages 31 into a first evaporation passage group 31a and a second evaporation passage group 31b (FIG. 2).

The lower tank portion group 23a forms a refrigerant inlet portion of the refrigerant evaporator 1. An inlet pipe 15 is connected to the second lower tank portion 23 of the right end downstream side passage tube 20. The inlet pipe 15 has an inlet passage communicating the downstream side heat exchanging unit 2 of the refrigerant evaporator 1 with a pressure reducing device (not shown) such as an expansion valve, a capillary tube or an orifice, as shown in FIG. 2.

The upper tank portion group 32a forms a refrigerant discharge portion of the refrigerant evaporator 1. A discharge pipe 16 is connected to the first upper tank portion 32 of the right end downstream side passage tube 30. The discharge pipe 16 has a discharge passage 16a communicating the upstream side heat exchanging unit 3 of the refrigerant evaporator 1 with the suction port of a refrigerant compressor (not shown). Thus, the inlet pipe 15 and the discharge pipe 16 extend from one side surface of the refrigerant evaporator 1, for instance, on the side of the engine compartment.

The end plate 6 and the side plate 7 will be described in detail with reference to FIG. 1. The end plate 6 is formed by

processing a metal plate, such as an aluminum alloy plate, and is joined to the left ends of the downstream side heat exchanging unit 2 and the upstream side heat exchanging unit 3. Elliptic communication holes 41 and 42 to be communicated with the communication hole 231 of the left end second lower tank portion 23 of the lower tank portion group 23b and the hole 321 of the left end first upper tank portion 32 of the upper tank portion group 32b are formed in a lower end portion and an upper end portion of the end plate 6, respectively.

10 The side plate 7 is formed by pressing a metal plate, such as an aluminum alloy plate and is provided with plural ribs (four ribs in this embodiment) 43. When the side plate 7 is joined to the end plate 6, plural communication passages (four communication passages in this embodiment) 44 are formed between 15 the inner surfaces of the ribs 43 and the outer surface of the end plate 6. The communication passages 44 communicate the lower tank portion group 23b of the second lower tank 25 with the upper tank portion group 32b of the first upper tank 34, and serve as one-way passages for leading the refrigerant flowing from the second lower tank 25 toward the first upper tank 34.

20 A downstream side refrigerant passage A is formed in the downstream side heat exchanging unit 2 by the separator 27, and an upstream side refrigerant passage B is formed in the upstream side heat exchanging unit 3 by the separator 36.

25 As shown in FIG. 2, the refrigerant flowing through the inlet passage 15a of the inlet pipe 15 is introduced through the downstream side refrigerant passage A of the downstream side heat

exchanging unit 2, i.e., through the lower tank portion group 23a among the plural downstream side lower tank portions 23, the first evaporation passage group 21a among the plural downstream side evaporation passages 21, the plural downstream side upper tank portions 22, the second evaporation passage group 21b among the plural downstream side evaporation passages 21, the lower tank portion group 23b among the plural downstream side lower tank portions 23, and the communication passages 44 in this order.

10           The refrigerant flowing into the communication passages 44 is introduced through the upstream side refrigerant passage B, i.e., flows through the upper tank portion group 32b among the plural upstream side upper tank portions 32, the second evaporation passage group 31b among the plural upstream side evaporation passages 31, the plural upstream side lower tank portions 33, the first evaporation passage group 31a among the plural upstream side evaporation passages 31, the upper tank portion group 32a among the plural upstream side upper tank portions 32, and the discharge passage 16a of the discharge pipe 16 in this order.

20           An operation of the refrigerant evaporator in this embodiment will briefly be described with reference to FIGS. 1 to 5.

25           The low-temperature, low-pressure gas-liquid two-phase refrigerant which has been adiabatically expanded in the pressure reducing device flows through the inlet passage 15a of the inlet pipe 15 into the lower tank portion group 23a among the plural

downstream side lower tank portions 23. Then, the refrigerant is distributed to the downstream side evaporation passages 21 of the first evaporation passage group 21a among the plural downstream side evaporation passages 21.

5 As shown in FIG. 4, the liquid-phase refrigerant among the gas-liquid two-phase refrigerant flowing through the lower tank portion group 23a flows into a downstream section (a rear side) of the lower tank portion group 23a by inertia, and the gas-phase refrigerant flows into an upstream section (a front side) of the lower tank portion group 23a. Consequently, the  
10 liquid-phase refrigerant is easy to flow into the downstream side lower evaporation passages 21 in a downstream section of the first evaporation passage group 21a, and the gas-phase refrigerant is easy to flow into the downstream side lower  
15 evaporation passages 21a in an upstream section of the first evaporation passage group 21a

Accordingly, the efficiency of heat transfer from air flowing outside the plural downstream side passage tubes 20 to the refrigerant flowing through the downstream side evaporation passages 21 in the downstream section of the first evaporation  
20 passage group 21a is higher than that of heat transfer from air flowing outside the plural downstream side passage tubes 20 to the refrigerant flowing through the downstream side evaporation  
25 passages 21 in the upstream section of the first evaporation passage group 21a.

Consequently, air flowing outside the downstream side evaporation passages 21 in the downstream section of the first

evaporation passage group 21a is cooled more efficiently than air flowing outside the downstream side evaporation passages 21 in the upstream section of the first evaporation passage group 21a. Air flowing outside the downstream side evaporation passages 21  
5 in the upstream section of the first evaporation passage group 21a is not cooled efficiently.

Thus, the refrigerant flowing through the first evaporation passage group 21a is evaporated and gasified by the heat exchange with air, and the liquid-phase dominant gas-liquid  
10 two-phase refrigerant flows into the plural downstream side upper tank portions 22, and then flows through the downstream side upper tank portions 22 in the left half section into the downstream side evaporation passages 21 of the second evaporation passage group 21b among the plural downstream side  
15 evaporation passages 21.

As shown in FIG. 5, the liquid-phase refrigerant among the refrigerant flowing through the downstream side upper tank portions 22 in the left half section mainly flows into an  
upstream section by its gravity, and the gas-phase refrigerant  
20 mainly flows into a downstream section. Consequently, the liquid-phase refrigerant is easy to flow into the downstream side evaporation passages 21 in an upstream section of the second evaporation passage group 21b among those of the second  
evaporation passage group 21b, and the gas-phase refrigerant is  
25 easy to flow into the downstream side evaporation passages 21 in a downstream section of the second evaporation passage group 21b among those of the second evaporation passage group 21b.

Accordingly, the heat exchange efficiency between air flowing outside the plural downstream side passage tubes 20 and the refrigerant flowing through the downstream side evaporation passages 21 in the upstream section of the second evaporation passage group 21b is higher than that between air flowing outside the plural downstream side passage tubes 20 and the refrigerant flowing through the downstream side evaporation passages 21 in the downstream section of the first evaporation passage group 21b.

Consequently, air flowing outside the downstream side evaporation passages 21 in the upstream section of the second evaporation passage group 21b is cooled more efficiently than air flowing outside the downstream side evaporation passages 21 in the downstream section of the second evaporation passage group 21b. Air flowing outside the downstream side evaporation passages 21 in the downstream section of the second evaporation passage group 21b is not cooled efficiently.

Thus, the refrigerant flowing through the second evaporation passage group 21b is evaporated and gasified by the heat exchange with air to be the gas-liquid two-phase refrigerant having the liquid-phase dominant to some extent, and after flowing into the downstream side upper tank portions 22 of the upper tank portion group 22b, flows through the communication passages 45 into the upper tank portion group 32b of the upstream side heat exchanging unit 3. The refrigerant entered the upper tank portion group 32b is distributed to the upstream side evaporation passages 31 of the second evaporation passage group

31b.

AS shown in FIG. 5, similarly to the flow of the refrigerant in the downstream side upper tank portions 22 in the left half section, the liquid-phase refrigerant mainly flows into an upstream section of the upper tank portion group 32b and the gas-phase refrigerant mainly flows into a downstream section of the upper tank portion group 22b. Consequently, the liquid-phase refrigerant is easy to flow into the upstream side evaporation passages 31 in an upstream section of the second evaporation passage group 31b and the gas-phase refrigerant is easy to flow into the upstream side evaporation passages 31 in a downstream section of the second evaporation passage group 31b.

Accordingly, the heat exchange efficiency between the air flowing outside the plural rear passage tubes 20 and the refrigerant flowing through the front evaporation passages 31 in the upstream section of the second evaporation passage group 31b is higher than that between the air and the refrigerant flowing through the front evaporation passages 31 in the downstream section of the second evaporation passage group 31b.

Consequently, air flowing outside the upstream side evaporation passages 31 in the upstream section of the second evaporation passage group 31b is cooled more efficiently than air flowing outside the upstream side evaporation passages 31 in the downstream section of the second evaporation passage group 31b. Air flowing outside the upstream side evaporation passages 31 in the downstream section of the second evaporation passage group 31b is not cooled efficiently.



Thus, the refrigerant flowing through the second evaporation passage group 31b is evaporated and gasified by heat exchange with air to be the gas-phase dominant gas-liquid two-phase refrigerant and flows into the upstream side lower tank sections 33. Then, the refrigerant entered the upstream side lower tank portions 33 in the right half section is distributed to the upstream side evaporation passages 31 of the first evaporation passage group 31a.

As shown in FIG. 4, similarly to the refrigerant in the lower tank portion group 23a, the liquid-phase refrigerant among the gas-liquid two-phase refrigerant mainly flows into the lower tank portions 33 in a downstream section, and the gas-phase refrigerant mainly flows in the lower tank portions 33 in an upstream section. Therefore, the liquid-phase refrigerant is easy to flow into the upstream side evaporation passages 31 in the downstream section of the first evaporation passage group 31a, and the gas-phase refrigerant is easy to flow into the upstream side evaporation passages 31 in the upstream section of the first evaporation passage group 31a.

Accordingly, the efficiency of heat transfer from air flowing outside the plural upstream side passage tubes 30 to the refrigerant flowing through the upstream side evaporation passages 31 in the downstream section is higher than that of heat transfer from air flowing outside the plural upstream side passage tubes 30 to the refrigerant flowing through the upstream side evaporation passages 31 in the upstream section.

Consequently, air flowing outside the upstream side

evaporation passages 31 in the downstream section of the first evaporation passage group 31a is cooled efficiently by the liquid-phase refrigerant. Air flowing outside the upstream side evaporation passages 31 in the upstream section is not cooled efficiently.

5

Thus, the refrigerant flowing through the first evaporation passage group 31a is evaporated and gasified by heat exchange with air to be a superheated vapor (superheated gas), and flows through the upstream side upper tank portions 32 of the upper tank portion group 32a into the discharge passage 16a of the discharge pipe 16. Subsequently, the superheated vapor of the refrigerant flows through a refrigerant discharge pipe (not shown), and is sucked through the suction port into the refrigerant compressor.

10

15

An effect of the first embodiment will be described.

In this embodiment, in the refrigerant evaporator 1, of the plural downstream side evaporation passages 21 and the plural upstream side evaporation passages 31 are divided into two groups substantially at the middles thereof with respect to the width, the refrigerant flows in the same direction through the first evaporation passage group 21a of the downstream side heat exchanging unit 2 and the first evaporation passage group 31a of the upstream side heat exchanging unit 3 overlapping with the first evaporation passage group 21a of the downstream side heat exchanging unit 2, and flows in the same direction through the second evaporation passage group 21b of the downstream side heat exchanging unit 2 and the second evaporation passage group 31b

20

25

of the upstream side heat exchanging unit 3 overlapping with the second evaporation passage group 21b of the downstream side heat exchanging unit 2.

Accordingly, as shown in FIG. 4, an efficient heat exchange area 2a in the first evaporation passage group 21a in which the liquid-phase refrigerant is easy to flow, and an efficient heat exchange area 3a in the first evaporation passage group 31a in which the liquid-phase refrigerant is easy to flow are symmetrical with each other. Similarly, an inefficient heat exchange area 2c in the first evaporation passage group 21a in which the liquid-phase refrigerant is hard to flow and an inefficient heat exchange area 3c in the first evaporation passage group 31a in which the liquid-phase refrigerant is hard to flow are symmetrical with each other.

As shown in FIG. 5, an efficient heat exchange area 2b in the second evaporation passage group 21b in which the liquid-phase refrigerant is easy to flow, and an efficient heat exchanging area 3b in the second evaporation passage group 31b in which the liquid-phase refrigerant is easy to flow are symmetrical with each other. Similarly, an inefficient heat exchange area 2d in the second evaporation passage group 21b in which the liquid-phase refrigerant is hard to flow and an inefficient heat exchange area 3d in the second evaporation passage group 31b in which the liquid-phase refrigerant is hard to flow are symmetrical with each other.

Thus, the respective inefficient heat exchange areas of the downstream side heat exchanging unit 2 and the upstream side

heat exchanging unit 3 disposed so as to overlap with each other with respect to the airflow direction do not overlap with each other with respect to the airflow direction. Consequently, the biased temperature distribution of air cooled by heat exchange  
5 can be prevented, and air having uniform temperature distribution can be blown out from the refrigerant evaporator 1.

A second embodiment of the present invention will be described.

FIG. 6 shows a left-right two-sectioned refrigerant  
10 evaporator 1 in the second embodiment according to the present invention.

In the refrigerant evaporator 1 in this embodiment, a downstream side lower tank 25 of a downstream side heat exchanging unit 2 and an upstream side upper tank 34 of an upstream side heat exchanging unit 3 are communicated by a  
15 communication pipe 17 to introduce the refrigerant in one direction from the downstream side heat exchanging unit 2 to the upstream side heat exchanging unit 3. The connecting pipe 17 is attached to the outer surface of a flat side plate 7 to form a  
20 communication passage of a circular, a C-shaped, a U-shaped or V-shaped cross section in the communication pipe 17 or between the communication pipe 17 and the side plate 7. A hole (not shown) formed at a position in a lower end portion on the downstream side and a hole (not shown) at a position in an upper  
25 end portion on the upstream side of the side plate 7 are communicated by the communication passage.

A third embodiment of the present invention will be

described.

FIG. 7 shows the flow of a refrigerant in a left-right three-sectioned refrigerant evaporator (hereinafter referred to simply as "refrigerant evaporator") 1 in the third embodiment according to the present invention.

In this refrigerant evaporator 1, a downstream side upper tank 24 and an upstream side lower tank 35 are communicated, and the refrigerant flows in one direction from a downstream side heat exchanging unit 2 toward an upstream side heat exchanging unit 3 through a communication passage 45.

The downstream side heat exchanging unit 2 is provided with a separator 26 for dividing plural downstream side upper tank portions 22 of the downstream side heat exchanging unit 2 into two upper tank portion groups 22a and 22b, and a separator 27 for dividing plural downstream side lower tank portions 23 into two lower tank portion groups 23a and 23b. The separators 26 and 27 divide plural downstream side evaporation passages 21 into three evaporation passage groups, i.e., a first evaporation passage group 21a, a second evaporation passage group 21b and a third evaporation passage group 21c.

The upstream side heat exchanging unit 3 is provided with a separator 36 for dividing plural upstream side upper tank portions 32 into two upper tank portion groups 32a and 32b, and a separator 37 for dividing plural upstream side lower tank portions 33 into two lower tank portion groups 33a and 33b. The separators 36 and 37 divide plural upstream side evaporation passages 31 into three evaporation passage groups, i.e., a first

evaporation passage group 31a, a second evaporation passage group 31b and a third evaporation passage group 31c.

The refrigerant flowing through an inlet passage 15a is introduced through a downstream side refrigerant passage A formed  
5 in the downstream side heat exchanging unit 2, i.e., through the lower tank portion group 23a, the first evaporation passage group 21a, the upper tank portion group 22a, the second evaporation passage group 21b, the lower tank portion group 23b, the third evaporation passage group 21c, the upper tank portion group 22b,  
10 and the communication passage 45 in this order.

The refrigerant flowing from the communication passage 45 is introduced through an upstream side refrigerant passage B, i.e., through the lower tank portion group 33b, the third evaporation passage group 31c, the first evaporation passage group 31a and the upper tank portion group 32a, and a discharge passage 16a in this order.  
15

A fourth embodiment of the present invention will be described.

FIG. 8 shows the flow of a refrigerant in a right-left four-sectioned refrigerant evaporator (hereinafter referred to simply as "refrigerant evaporator") 1 in the fourth embodiment according to the present invention.  
20

A downstream side heat exchanging unit 23 is provided with a separator 26 for dividing plural downstream side upper tank portions 22 into two upper tank portion groups 22a and 22b, and separators 27 and 28 for dividing plural downstream side lower tank portions 23 into three lower tank portion groups 23a  
25

to 23c. The separators 26 to 28 divide plural downstream side evaporation passages 21 into four evaporation passage groups, i.e., a first evaporation passage group 21a, a second evaporation passage group 21b, a third evaporation passage group 21c and a fourth evaporation passage group 21d.

An upstream side heat exchanging unit 3 is provided with separators 36 and 38 for dividing plural upstream side upper tank portions 32 into three upper tank portion groups 32a to 32c, and a separator 37 dividing plural upstream side lower tank portions 33 into two lower tank portion groups 33a and 33b. The separators 36 to 38 divide plural downstream side evaporation passages 31 into four evaporation passages, i.e., a first evaporation passage group 31a, a second evaporation passage group 31b, a third evaporation passage group 31c and a fourth evaporation passage group 31d.

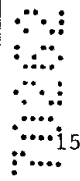

The refrigerant flowing through an inlet passage 15a is introduced through a downstream side refrigerant passage A formed in the downstream side heat exchanging unit 2, i.e., through the lower tank portion group 23a, the first evaporation passage group 21a, the upper tank portion group 22a, the second evaporation passage group 21b, the lower tank portion group 23b, the third evaporation passage group 21c and the upper tank portion group 22b, the fourth evaporation passage group 21d, the lower tank portion group 23c, and a communication passage 44 in this order.

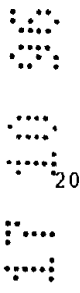

The refrigerant flowing from the communication passage 44 is introduced through an upstream side refrigerant passage B, i.e., through the upper tank portion group 32c, the fourth

evaporation passage group 31d, the lower tank portion group 33b,  
the third evaporation passage group 31c, the upper tank portion  
group 32b, the second evaporation passage group 31b, the lower  
tank portion group 33a, the first evaporation passage group 31a,  
5 the upper tank portion group 32a, and a discharge passage 16a in  
this order.

A fifth embodiment of the present invention will be  
described.

10 FIG. 9 shows the flow of a refrigerant in a one-way type  
refrigerant evaporator (hereinafter referred to simply as  
"refrigerant evaporator") 1 in the fifth embodiment according to  
the present invention.

15  
20

In this embodiment, the refrigerant flowing through a  
inlet passage 15a is introduced through a downstream refrigerant  
passage A formed in the downstream side heat exchanging unit 2,  
i.e., through plural downstream lower tank portion 23, plural  
downstream side evaporation passages 21, plural downstream side  
upper tank portions 22, and a communication passage 45, in this  
order. The refrigerant flowing from the communication passage  
20 44 is introduced through an upstream side refrigerant passage B,  
i.e., through plural upstream side lower tank portions 33, the  
plural upstream side evaporation passages 31, plural upstream  
side upper tank portions 32, and a discharge passage 16a.

25 Although the present invention is applied to the  
refrigerant evaporator 1 constructed by laminating plural flat  
passage tubes formed by joining together the pair of pressed  
plates 4 in this embodiment, the present invention can be applied



to plate-fin tube type refrigerant evaporators and multiflow type refrigerant evaporator having flat tubes internally provided with plural refrigerant passages.

In the foregoing embodiments, the refrigerant evaporator  
5 1 is disposed with its height in a vertical direction and its width in a horizontal direction, and the plural downstream side evaporation passages 21 and the plural upstream side evaporation passages 31 are disposed so that the refrigerant flows vertically. The same effects as those of the foregoing  
10 embodiments can be obtained by a modification in which a refrigerant evaporator 1 is disposed with its height inclined to a vertical direction, and plural downstream side evaporation passages 21 and plural upstream side evaporation passages 31 are inclined to a vertical direction so that the refrigerant flows in directions inclined to a vertical direction.

Although the refrigerant inlet passage is formed in the downstream side lower tank portion 23 of the lower tank portion group 23a, and the refrigerant discharge passage is formed in the upstream side upper tank portion 32 of the upper tank portion group 32a in the foregoing embodiments, the plural downstream  
15 side upper tank portions 22 may be divided into an odd or even number of downstream side upper tank portion groups, the refrigerant inlet passage may be formed in the downstream side upper tank portion 22 of the upper tank portion group 22a on the  
20 most upstream side with respect to the flowing direction of the refrigerant, the plural upstream side lower tank portions 23 may be divided into an odd or even number of groups, and the

refrigerant discharge passage may be formed in the upstream side lower tank portion 33 of the lower tank portion group 33a on the most downstream side with respect to the flowing direction of the refrigerant; that is, the refrigerant evaporator 1 in each of the  
5 foregoing embodiments may be disposed upside down.

The first evaporation passages may be divided into an even number of evaporation passage groups by separators and the second evaporation passages may be divided into an odd number of evaporation passage groups by separators. When the first and the  
10 second evaporation passages are thus divided, the refrigerant flows in the same vertical direction only in some of the first evaporation passages and some of the second evaporation passages overlapping with the first evaporation passages, and the refrigerant inlet passage and the refrigerant discharge passage are formed side by side in the first and the second upper or in  
15 the first and the second lower tank.

Although the inlet pipe 15 and the discharge pipe 16 are attached to the refrigerant evaporator while being apart from each other in the embodiments illustrated in FIGS. 1 to 9, the refrigerant evaporator may be provided with a side plate 50 to  
20 form the inlet passage and the discharge passage adjacent to each other as shown in FIG. 11, and the inlet pipe 15 and the discharge pipe 16 may be gathered on and connected to a long cylindrical joint 51 attached to an upper portion of the side  
25 plate 50.

The inlet pipe 15 and the discharge pipe 16 may be gathered on the central portion of the side plate 50 as shown in

FIG. 12. In this case, long sides of the joint 51 may be attached while being inclined as shown in FIG. 13, or long sides of the joint 51 may be attached while being extended transversely as shown in FIG. 14.

5 The inlet pipe 15 and the discharge pipe 16 may be extended so as to project on the upstream side or on the downstream side of the refrigerant evaporator as shown in FIG. 15.

10 Although the present invention has been fully described in connection with the preferred embodiments thereof with reference to the accompanying drawings, it is to be noted that various changes and modifications will become apparent to those skilled in the art. Such changes and modifications are to be understood as being included within the scope of the present invention as defined in the appended claims.

15  
20  
25  
30  
35

**THE CLAIMS DEFINING THE INVENTION ARE AS FOLLOWS:**

1. A refrigerant evaporator for evaporating refrigerant flowing therein to cool outside air flowing therethrough said evaporator comprising:

5 first evaporation passage means for defining plural first evaporation passages through which the refrigerant flows, said plural first evaporation passages being formed substantially vertically and arranged substantially in parallel with each other in a direction  
10 substantially perpendicular to the flowing direction of said outside air;

a first tank portion connected to each of upper ends and lower ends of said plural first evaporation passages, said first tank portion extending in a direction crossing  
15 said first evaporation passages;

second evaporation passage means for defining plural second evaporation passages through which the refrigerant flows, said plural second evaporation passage being formed substantially vertically and arranged  
20 substantially in parallel with each other in a direction substantially perpendicular to the flowing direction of said outside air, said plural second evaporation passages being disposed adjacent to said first evaporation passages at a downstream side of the evaporator with respect to the flow direction of said outside air;

a second tank portion connected to each of upper ends and lower ends of said plural second evaporation passages, and said second tank portion extending in a direction crossing said second evaporation passages; and  
25

30 communication means for defining a communication passage for communicating between said plural first evaporation passages and said second evaporation passage, wherein:

35 the refrigerant flows in the same vertical direction at least in portions where said plural first evaporation passages are aligned in the flow direction of the outside air and said plural second evaporation passages are aligned in the flow direction of the outside air; and

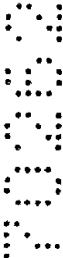

S:14339BF/703

said first tank portion has a first refrigerant distributing portion through which refrigerant is distributed into said first evaporation passages, and a first refrigerant joining portion into which refrigerant  
5 having passed through said first evaporation passages flows;

said second tank portion has a second refrigerant distributing portion through which refrigerant is distributed into said second evaporation passages, and a  
10 second refrigerant joining portion into which refrigerant having passed through said second evaporation passages flows;

said first refrigerant distributing portion and said second refrigerant distributing portion are disposed in  
15 such a manner that the flow direction of refrigerant in said first refrigerant distributing portion is opposite to that in said second refrigerant distributing portion; and

said first refrigerant joining portion and said  
20 second refrigerant joining portion are disposed in such a manner that the flow direction of refrigerant in said first refrigerant joining portion is opposite to that in said second refrigerant joining portion.

2. A refrigerant evaporator according to claim 1,  
25 wherein:

said first tank portion includes a first upper tank connected to each of said upper ends of said first evaporation passages, and a first lower tank connected to each of said lower ends of said first evaporation  
30 passages; and

said second tank portion includes a second upper tank connected to each of said upper ends of said second evaporation passages, and a second lower tank connected to each of said lower ends of said second evaporation  
35 passages.

3. A refrigerant evaporator according to claim 2,  
wherein:

said second lower tank includes a refrigerant inlet at one end thereof:



said first upper tank includes a refrigerant outlet at one end thereof, and

refrigerant introduced through said refrigerant inlet into said second lower tank flows upward through all of said second evaporation passages, flows from said second upper tank through said communication passage into said first lower tank, flows upward through said first evaporation passages, and then flows outside through said refrigerant outlet.

4. A refrigerant evaporator according to claim 2, further comprising:

a first partition member for partitioning an interior of said first upper tank into plural sections; and

a second partition member for partitioning an interior of said second lower tank into plural sections.

5. A refrigerant evaporator according to claim 4, wherein the number of said sections of said first upper tank partitioned by said first partition member is equal to that of said second lower tank partitioned by said second partition member.

6. A refrigerant evaporator according to claim 5, wherein each interior of said first upper tank and said second lower tank is partitioned into two sections.

7. A refrigerant evaporator according to claim 5,

wherein each interior of said first upper tank and said second lower tank is divided into two sections, and each interior of said first lower tank and said second upper tank is divided into two sections.

8. A refrigerant evaporator according to claim 5, wherein each interior of said first upper tank and said second lower tank is divided into three sections, and each interior of said first lower tank and said second upper tank is divided into two sections.

9. A refrigerant evaporator according to claim 5, wherein,

said second lower tank includes a refrigerant inlet at one end thereof;

said first upper tank includes a refrigerant outlet at one end thereof; and

the other end of said second lower tank and the other end of said first upper tank are communicated by said communication passage.

10. A refrigerant evaporator according to claim 1, wherein,

each of said plural first evaporation passages overlaps with each of said plural second evaporation passages overlap with respect to the flowing direction of the outside air, and

each pair of directions of the refrigerant flowing

vertically in said first evaporation passage and said second evaporation passage, which overlap with each other, are the same.

5 11. A refrigerant evaporator according to claim 4, wherein said first evaporation passages are divided into an even number of evaporation passage groups, and said second evaporation passages are divided into an odd number of evaporation passages groups.

10 12. A refrigerant evaporator according to claim 2, wherein:

said first lower tank is said first refrigerant distributing portion, and said first upper tank is said first refrigerant joining portion; and

15 said second lower tank is said second refrigerant distributing portion, and said second upper tank is said refrigerant joining portion.

20 13. A refrigerant evaporator as claimed in claim 1, wherein the first refrigerant distributing portion and the second refrigerant distributing portion are disposed at the same side of the evaporator and at substantially the same height and the first refrigerant joining portion and the second refrigerant joining portion are disposed at the same side of the evaporator and at substantially the same height.

25 14. A refrigerant evaporator substantially in accordance with any one of the individual embodiments as herein described with reference to the accompanying drawings.

Dated this 28th day of January 1999

30 DENSO CORPORATION  
By their Patent Attorney  
GRIFFITH HACK



S:14339BF/703



FIG. 1

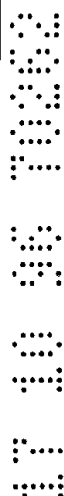
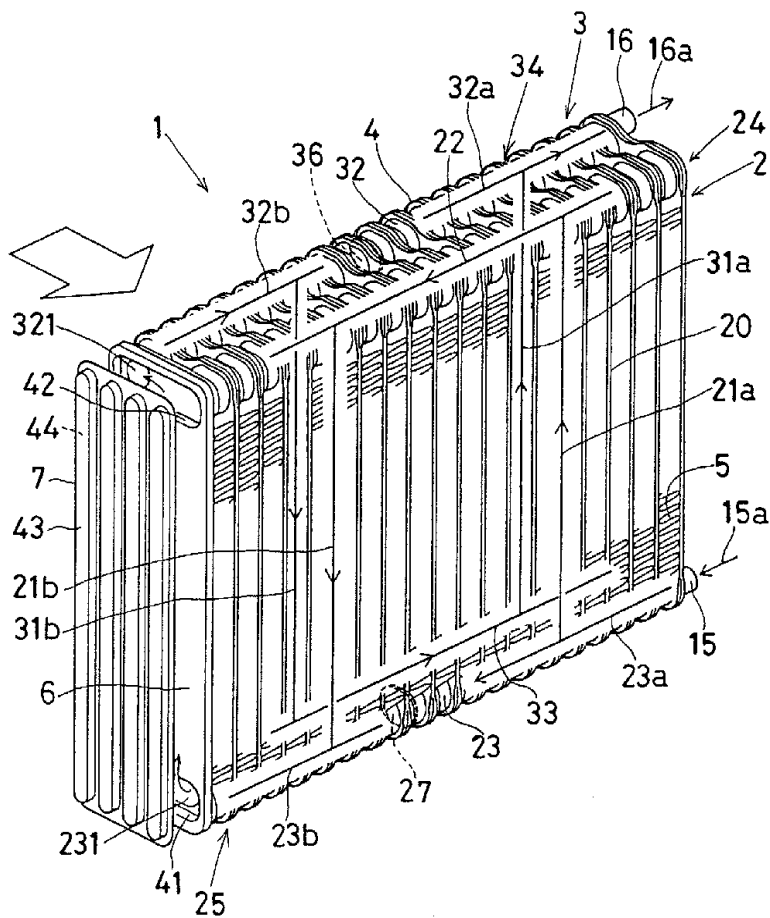

FIG. 2

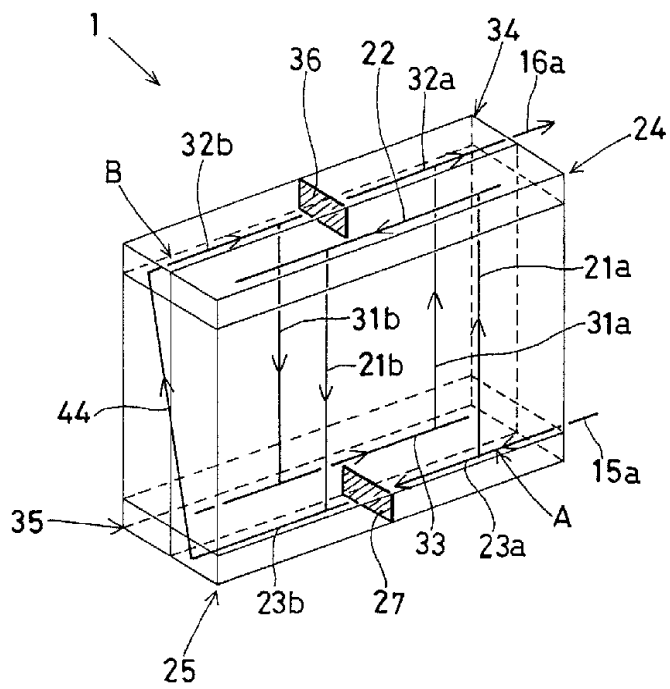

FIG. 9

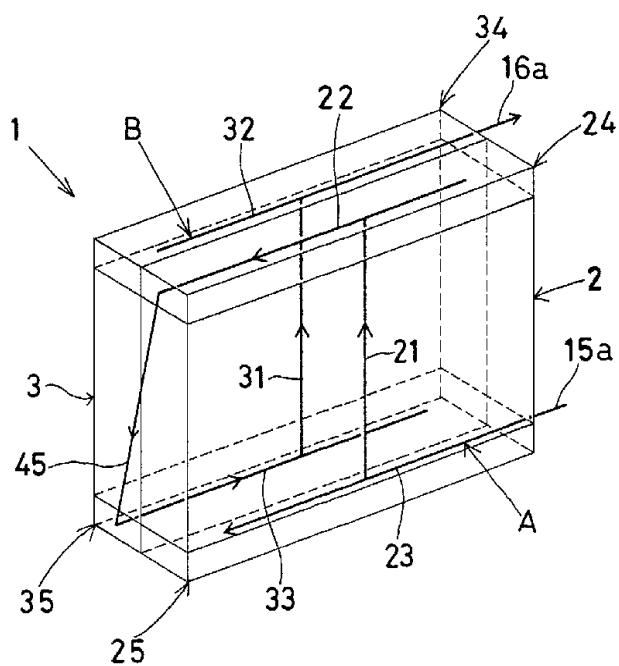

FIG. 3

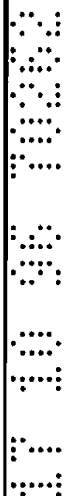
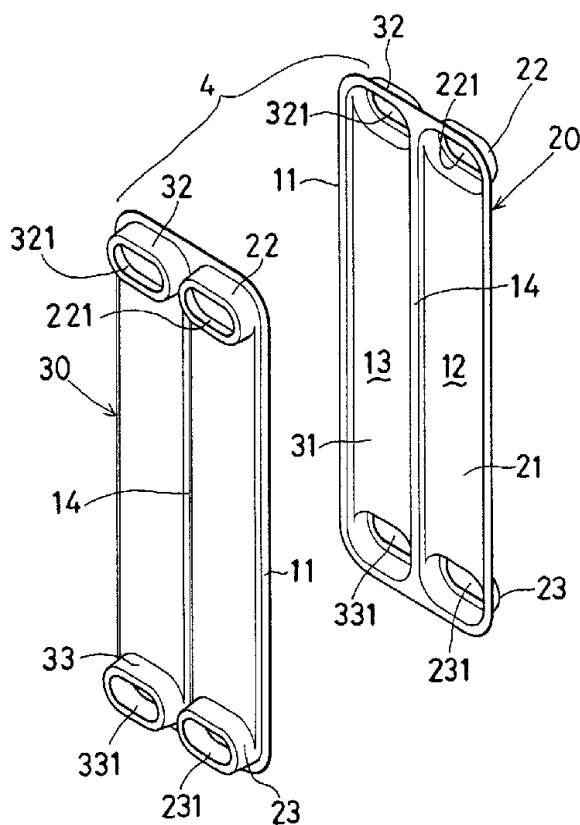

FIG. 4

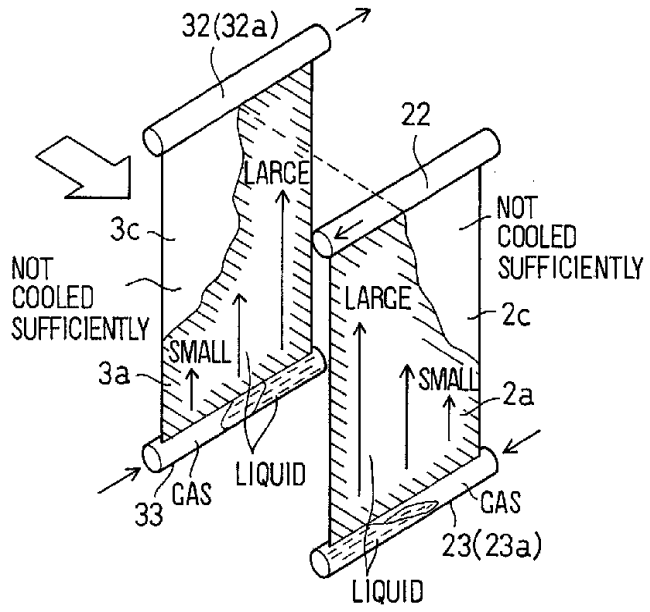

FIG. 5

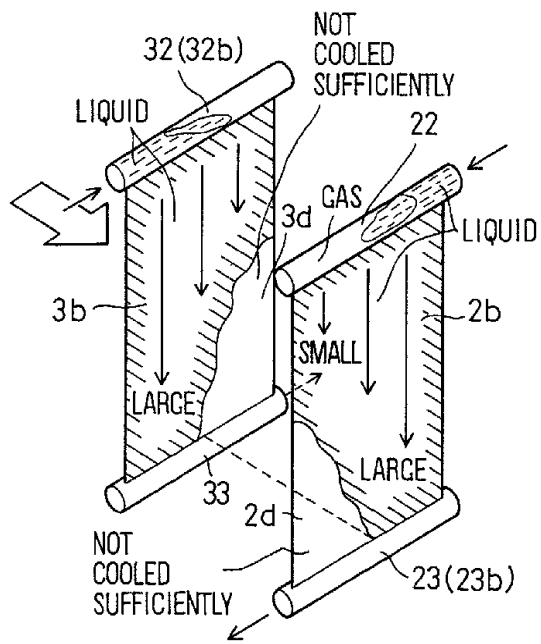

FIG. 6

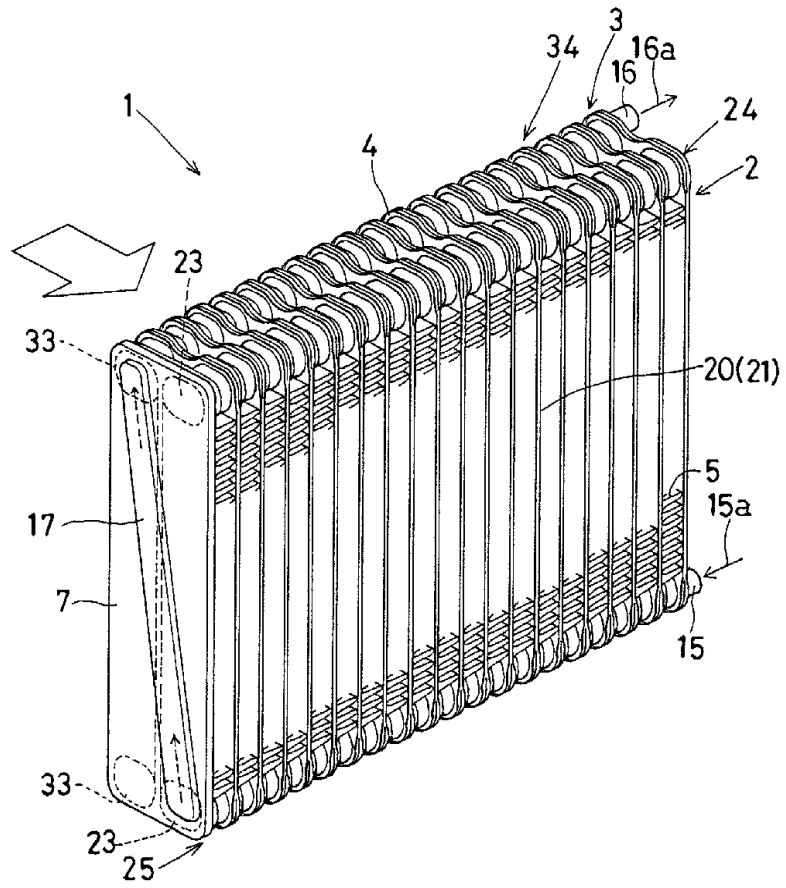

FIG. 7

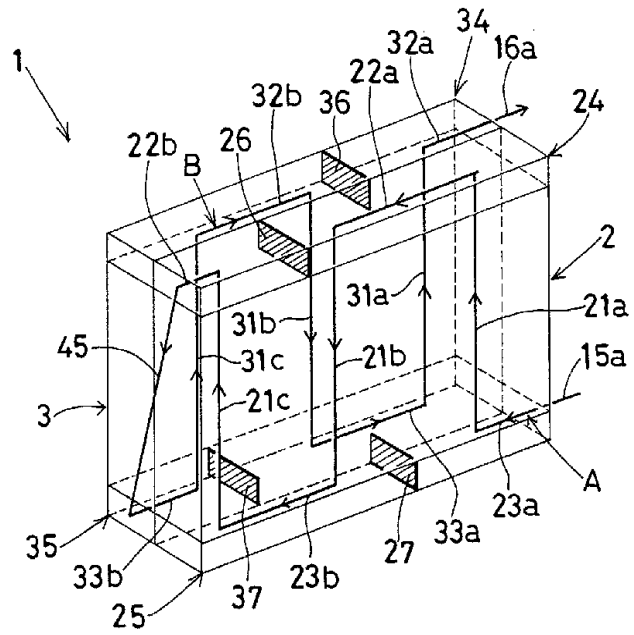

FIG. 8

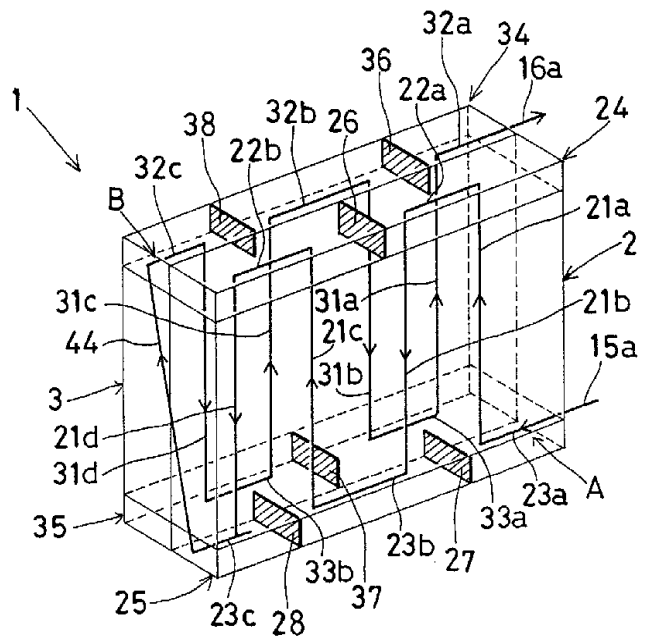
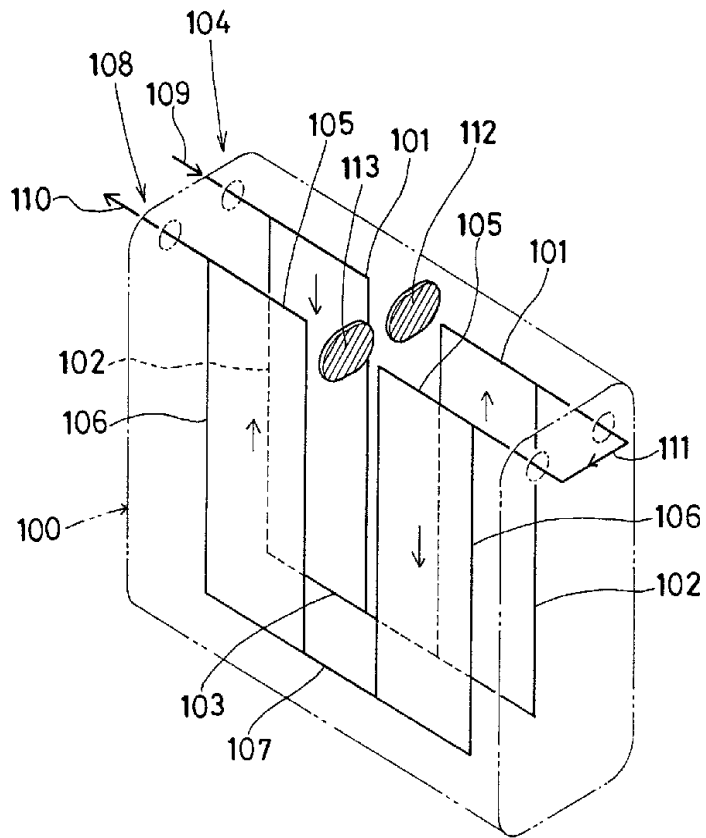

FIG. 10

PRIOR ART



NO  
A  
T

FIG. 11

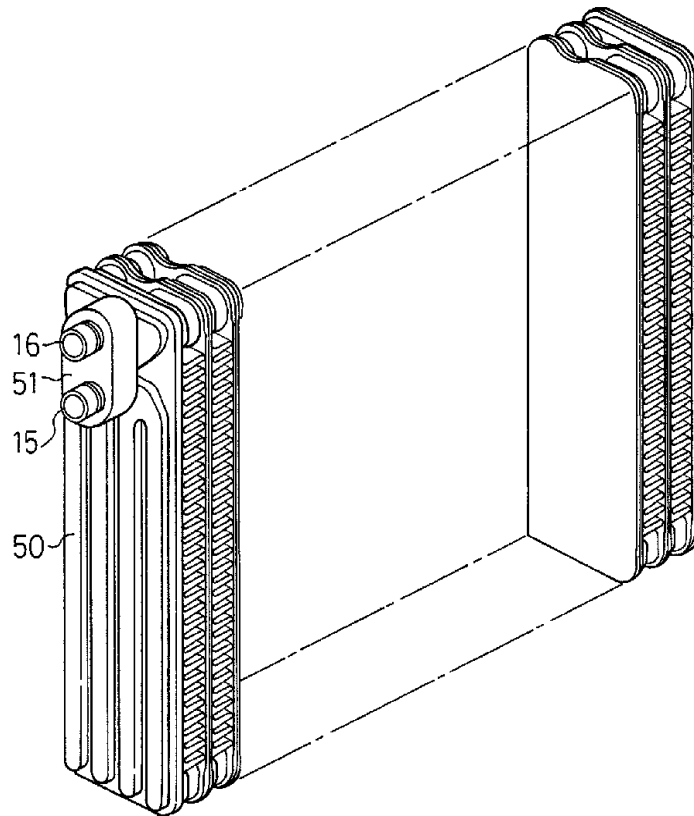

16  
51  
15  
50



FIG. 12

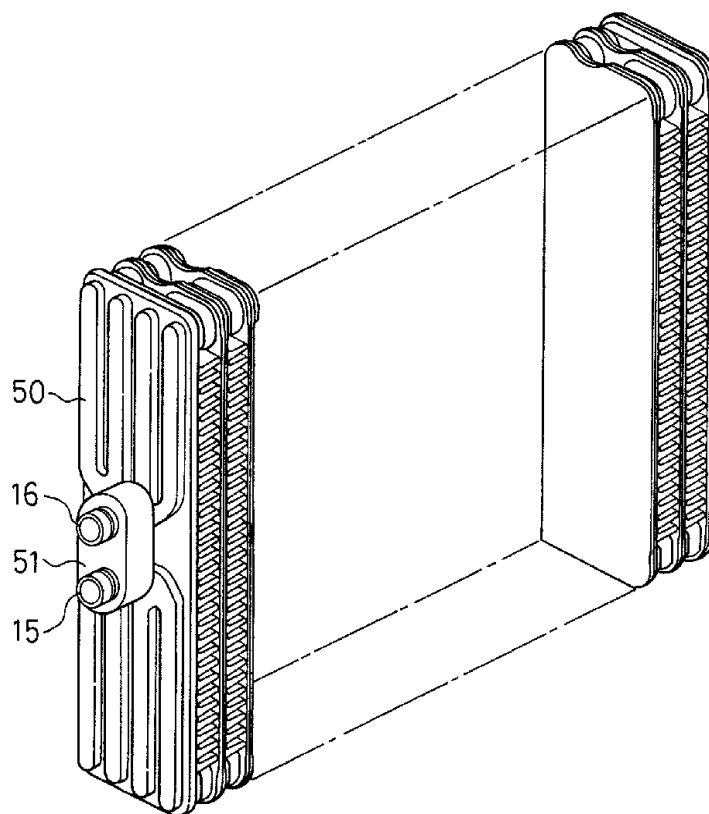

FOR INFORMATION

FIG. 13

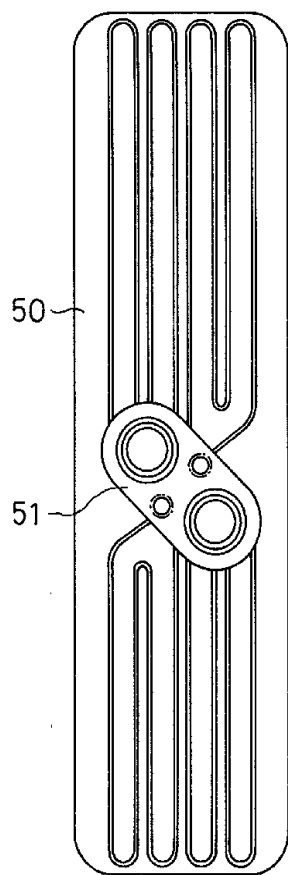
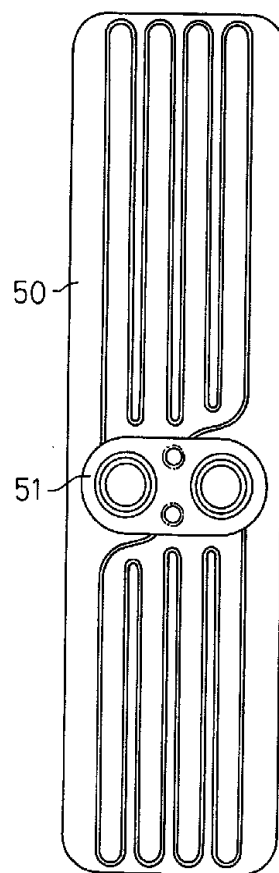
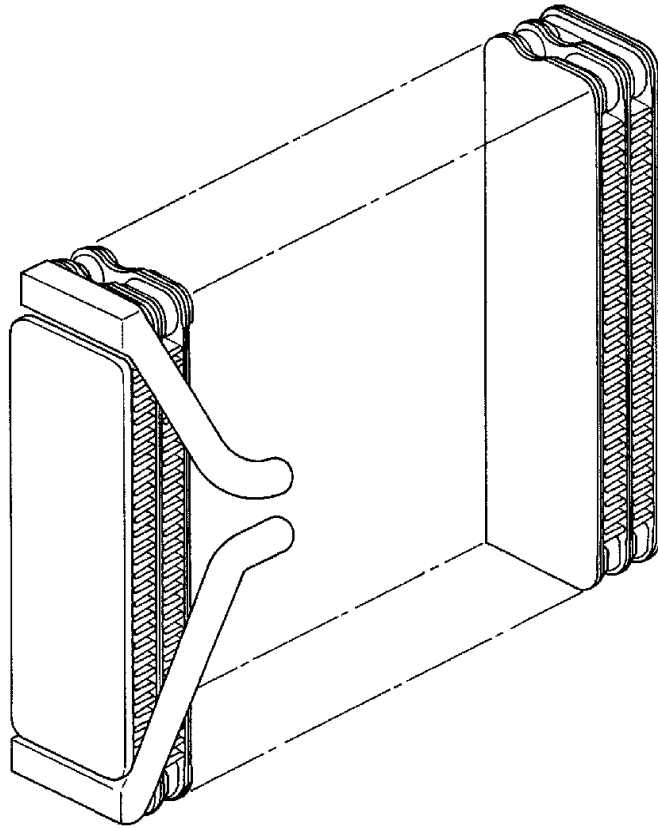

FIG. 14



FOR  
RE  
MI

FIG. 15



2025 05 17 10:00