

Dec. 11, 1956

J. O. SILVEY ET AL
TUNABLE COAXIAL LINE
Filed Aug. 9, 1952

2,774,044

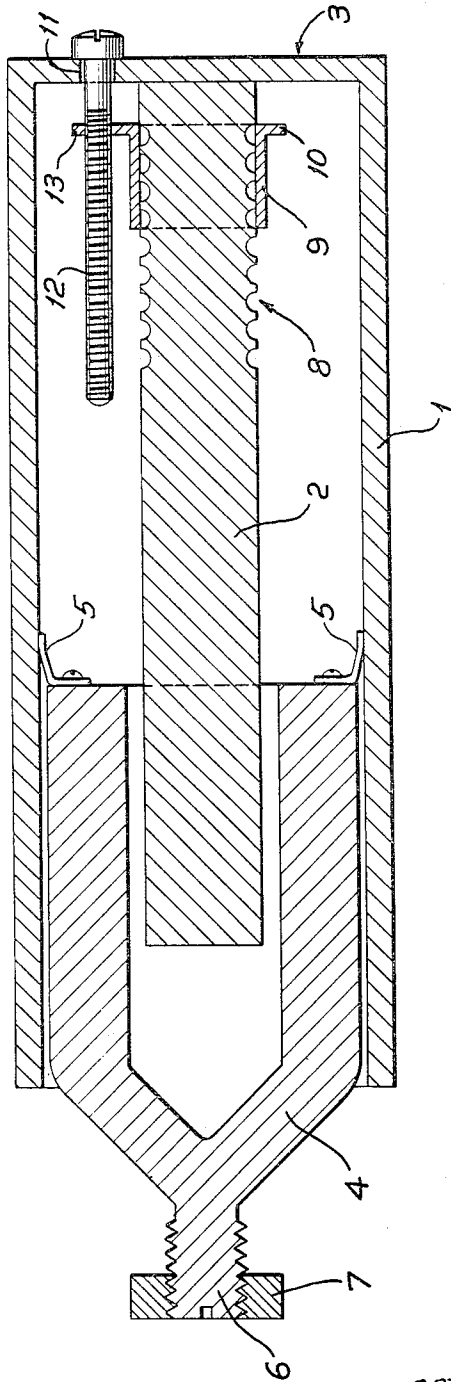

INVENTORS.
JOHN O. SILVEY
BY ORTIS C. BOOHER
Philip M. Bolton
ATTORNEY

1

2,774,044

TUNABLE COAXIAL LINE

John O. Silvey, Fort Wayne, and Ortis C. Booher, Huntington, Ind., assignors to International Telephone and Telegraph Corporation, a corporation of Maryland

Application August 9, 1952, Serial No. 303,456

2 Claims. (Cl. 333—82)

This invention relates to means for varying the electrical length of a line, and particularly to means for varying the inductance of a line without varying the physical length thereof.

This invention has particular applicability to tuning circuits of the coaxial line resonator type. Tunable coaxial resonator lines are known which employ capacitive tuning for varying the frequency of the line. An example of such tuning is disclosed in the copending application Serial No. 303,457, filed August 9, 1952, John O. Silvey inventor, assigned to the same assignee as this application, wherein there is shown a tuner for ultra high frequencies. Tuning or frequency variation is accomplished by varying the capacity between the inner and outer conductors of the coaxial line resonator. The coaxial line is short-circuited at one end and the capacity of the line is varied by positioning at the open end of the line a cap surrounding a portion of the inner conductor and contacting the outer conductor, thereby controlling the capacity between the conductors.

An important application of the present invention is in improving the tuning range of the above-mentioned coaxial line resonator by increasing the electrical length of the line.

An important object of the present invention is the provision of a simple and economical means for varying the electrical length of the tuned line.

A feature of the invention is the provision of means for varying the electrical length of the line without changing the physical length thereof.

Another object of the present invention is to provide an improved tunable circuit of the coaxial line type.

Another feature of the present invention is to provide an inner conductor for the coaxial line which is readily interchangeable and requires no change in the coaxial line for the utilization thereof.

In accordance with one aspect of applicants' invention there is provided a variable inductance line comprising a conductor having grooves formed on its surface thereof. A sleeve is provided which fits snugly over the conductor and movably over the grooves to short circuit variable numbers of said grooves, whereby the electrical length may be varied without changing the physical length of the line.

In accordance with another aspect of applicants' invention, there is provided a tunable coaxial line comprising an outer conductor and an inner conductor concentric therewith and spaced therefrom. The coaxial line is shorted at one end thereof and has positioned at the opposite end a capacitive cap for varying the capacity between the conductors. The inner conductor has grooves formed over a portion thereof to increase the inductance of the line so that the electrical length of the line is increased without increasing the physical length of the line.

The above-mentioned and other features and objects of this invention and the manner of attaining them will become more apparent and the invention itself will be

2

best understood, by reference to the following description of an embodiment of the invention taken in conjunction with the accompanying drawing, wherein the single figure shows a cross-sectional view of the tunable coaxial line resonator forming an embodiment of this invention.

Referring to the figure, there is shown a tunable coaxial line resonator comprising an outer conductor 1 and an inner conductor 2 concentric therewith and spaced therefrom. One end of the coaxial line may be shorted as shown at 3. At the open end of the line there is shown a movable conductive cap which is positioned over a portion of the inner conductor 2 and makes contact with outer conductor 1 by means, such as wiper strips 5. The conductive cap, which may be considered a capacitive cap since it varies the capacitance between the inner and outer conductors, has a threaded portion 6 which cooperates with a stationary threaded member 7, so that by rotating the cap, it is made to move longitudinally over the inner conductor 2.

The inner conductor has grooves generally indicated at 8 formed over a portion thereof to increase the inductance of the line. A sleeve 9 having a flange 10 at one end thereof may be slidably mounted on the inner conductor 2. The electrical length, or the inductance of the line is varied by moving the sleeve over the inner conductor 2, thereby shorting out a given number of grooves. At the shorted end 3 of the coaxial line there is provided an opening 11 for accommodating an adjusting screw 12. The flange is provided with a tapped hole for engaging the screw 12 and controlling the movement sleeve 9.

Thus it is seen that tuning of the line is characterized by both capacitive and inductive adjustments; the capacitive adjustment by cap 4 and the inductive adjustment by sleeve 9. By virtue of the capacitive and inductive adjustment means, a somewhat greater frequency coverage is made possible.

While we have described above the principles of our invention in connection with specific apparatus, it is to be clearly understood that this description is made only by way of example and not as a limitation of the scope of our invention as set forth in the objects thereof and in the accompanying claims.

We claim:

1. A tunable coaxial line comprising, an outer conductor, an inner conductor concentric therewith and spaced therefrom, means for short-circuiting said line at one end thereof, a movable conductive cap positioned at the opposite end of said line over a portion of said inner conductor and contacting said outer conductor, whereby the capacity between said conductors may be varied by moving said cap over said inner conductor; said inner conductor having circumferential grooves formed over a portion thereof, to increase the inductance of said line, a sleeve fitting snugly over a given portion of said grooves and moveable to short circuit a variable number of said grooves, whereby the electrical length of said line may be varied without increasing the physical length of said line.

2. A tunable coaxial line comprising an outer conductor, an inner conductor concentric therewith and spaced therefrom, means for short-circuiting said line at one end thereof, a movable conductive cap positioned at the opposite end of said line over a portion of said inner conductor and contacting said outer conductor, whereby the capacity between said conductors may be varied by moving said cap over said inner conductor; said inner conductor having circumferential grooves formed over a portion thereof, to increase the inductance of said line, a sleeve fitting snugly over a given portion of said grooves and moveable to short circuit a variable number of said

3

grooves, whereby the electrical length of said line may be varied without increasing the physical length of said line, said sleeve having a flange at one end extending radially outwardly therefrom, and means for longitudinally moving said sleeve over said grooves comprising a threaded member extending into the space between said outer and inner members, and threadedly engaging a hole provided in said flange, and said threaded member fitting in an aperture provided at the shorted end of said line, whereby said threaded member may be adjusted externally of said line to move the sleeve longitudinally along said inner conductor.

5

10

1,904,208
 2,222,902
 2,429,811
 2,567,748
 2,572,232
 2,579,315
 2,641,708
 2,659,817
 2,686,903
 2,714,192

4

References Cited in the file of this patent

UNITED STATES PATENTS

Dow -----	Apr. 18, 1933
Hahn -----	Nov. 26, 1940
Guarrera -----	Oct. 28, 1947
White -----	Sept. 11, 1951
Wolfe -----	Oct. 23, 1951
Gurewitsch -----	Dec. 18, 1951
Carlson -----	June 9, 1953
Cutler -----	Nov. 17, 1953
Pan -----	Aug. 17, 1954
Pan et al. -----	July 26, 1955