



(19) **United States**

(12) **Patent Application Publication**

Gueret

(10) **Pub. No.: US 2001/0001029 A1**

(43) **Pub. Date: May 10, 2001**

(54) **MAKE-UP BRUSH AND METHOD FOR MANUFACTURING SUCH A BRUSH**

(30) **Foreign Application Priority Data**

Feb. 8, 1993 (FR)..... 93 01344

(75) Inventor: **Jean-Louis H. Gueret, Paris (FR)**

Publication Classification

Correspondence Address:

**FINNEGAN, HENDERSON, FARABOW,
GARRETT &
DUNNER LLP
1300 I STREET, NW
WASHINGTON, DC 20005 (US)**

(51) **Int. Cl.⁷** **A46B 11/00; A46B 17/08;**
A 46B

(52) **U.S. Cl.** **401/122; 401/121; 15/206**

(73) Assignee: **L'Oreal of Paris, France**

(57) **ABSTRACT**

(21) Appl. No.: **09/754,287**

The brush (1) includes a core (2) formed from a metal wire bent into a U and the branches of which are twisted to trap radial bristles (3) between them, the core (2) being fixed to the end of a wand (6). The branches of the core are twisted, turning to the left, to form turns which turn in the clockwise direction about the axis (X) of the core when progressing from the wand towards the end of the brush, whereas the bristles (3) of the brush form helical layers (S) rising from left to right in the area located between the core and an observer who holds the brush substantially vertical in front of him/her with its tip pointing upwards.

(22) Filed: **Jan. 5, 2001**

Related U.S. Application Data

(63) Continuation of application No. 08/512,952, filed on Aug. 10, 1995, which is a continuation of application No. 08/179,700, filed on Jan. 11, 1994, now abandoned.

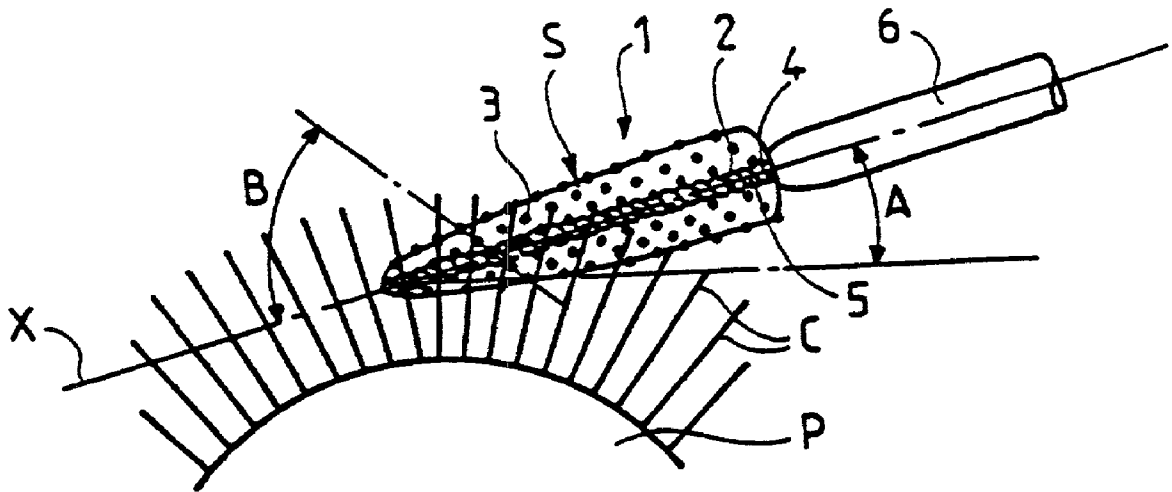

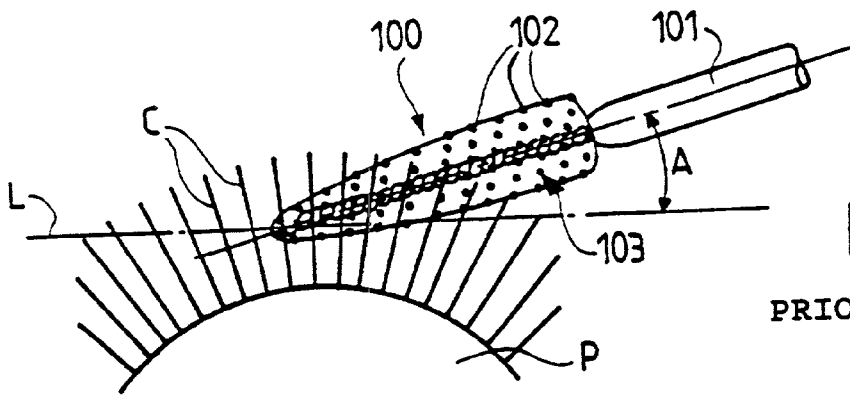

FIG. 1

PRIOR ART

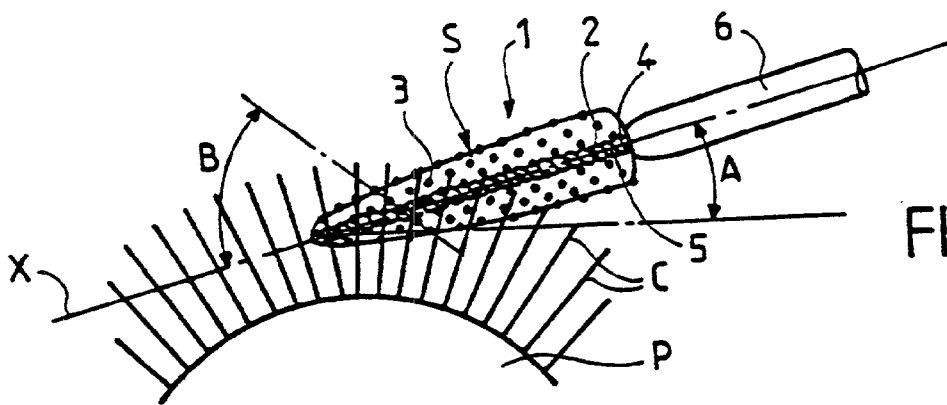

FIG. 2

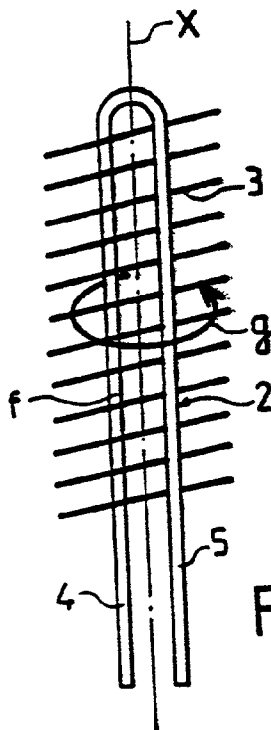

FIG. 3

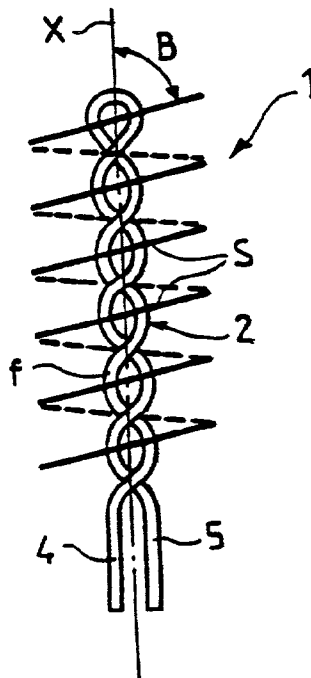
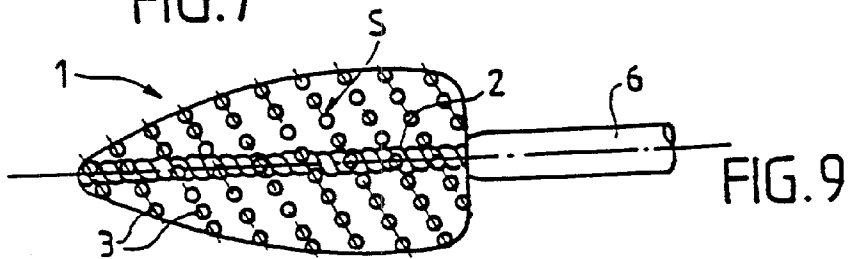
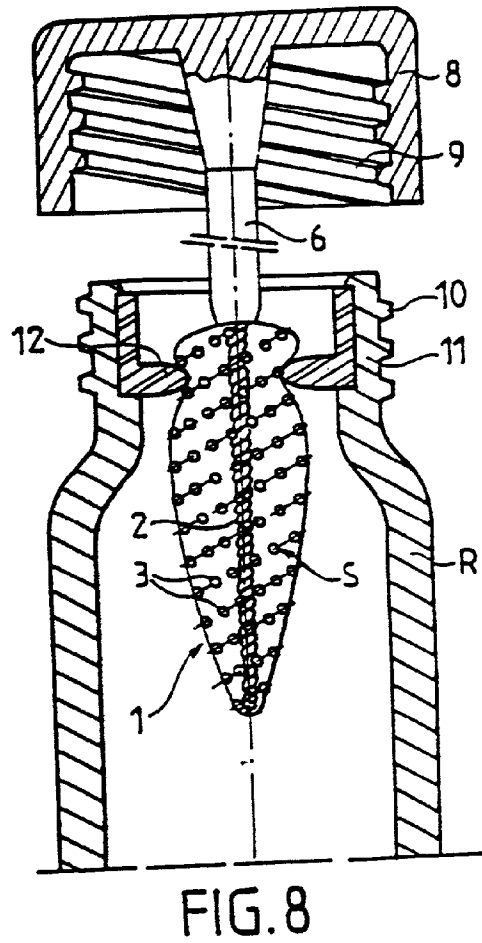
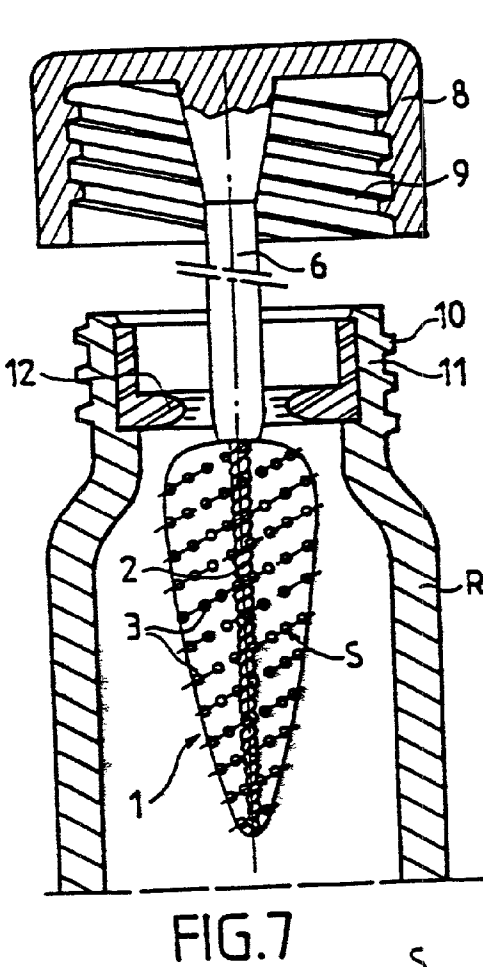
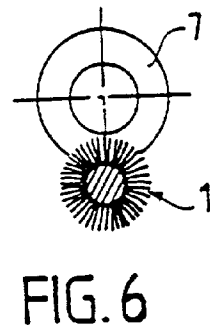
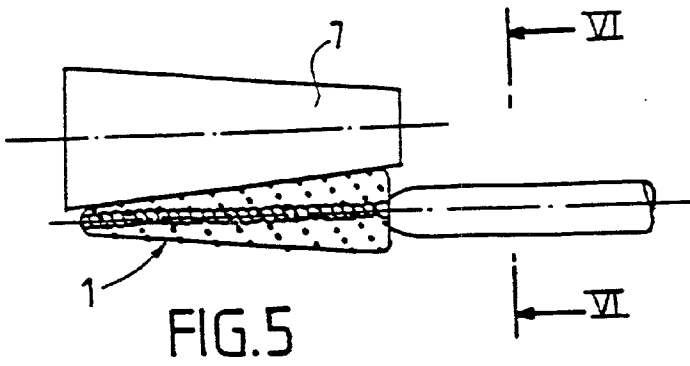

FIG. 4



MAKE-UP BRUSH AND METHOD FOR MANUFACTURING SUCH A BRUSH

[0001] The invention relates to a make-up brush, particularly for applying mascara to the eyelashes, of the type of those which include a core formed from a metal wire bent into a U and the branches of which are twisted to trap radial bristles between them, the core being fixed at the end of a wand.

[0002] A brush of this type is shown, for example, by FR-A-2,663,826.

[0003] When making-up, the user holds the wand of the brush forming a non-zero angle with respect to the mean transverse line of the two eyes. As a result, with conventional brushes known to date, the user frequently offers up the bristles of the brush in alignment with the eyelashes and deposits blobs of mascara, without separating the eyelashes. The make-up effect obtained therefore needs to be improved.

[0004] Furthermore, the brush is generally placed in a container containing the mascara, this container being equipped with a neck provided with a wringing device through which the brush passes. It is desirable for it to be possible for wringing to take place with lower resistance, giving a better smoothing of the product along the bristles.

[0005] The object of the invention, above all, is to provide a make-up brush, particularly for applying mascara to the eyelashes, which no longer exhibits the drawbacks recalled above, or exhibits them to a lesser degree.

[0006] According to the invention, a make-up brush of the sort defined previously is characterized in that the branches of the core are twisted, turning to the left, to form turns which, viewed along the axis of the core from that end which is fixed in the wand, turn in the clockwise direction about the axis of the core when progressing from the wand towards the end of the brush, whereas the bristles of the brush form helical layers rising from left to right in the area located between the core and an observer who holds the substantially vertical brush in front of him/her with its tip pointing upwards.

[0007] Preferably, the angle of inclination of the layers of bristles with respect to the axis is approximately 35°.

[0008] In general, the wand carrying the core includes, at its end distant from the core, a stopper provided with a screw thread for screwing onto the neck of a container containing the mascara, this neck being equipped with a wringing device through which the brush passes when it is withdrawn from the container; according to the invention, the branches of the core of the brush are twisted to form turns turning in the same direction as the screw thread of the stopper.

[0009] In practice, the direction of screwing of the stopper relative to the container is the clockwise direction, and the branches of the core are twisted so that the turns turn in the clockwise direction about the axis of the core when progressing from that part of the core which is fixed in the wand towards the free end of the core.

[0010] Thus, the rotational movement for unscrewing the stopper relative to the neck takes place in the same direction as the rotational movement which unscrews the brush relative to the wringing device.

[0011] The invention also relates to a method for manufacturing a make-up brush, according to which method, after having folded a metal wire over into a U, and after having placed bristles between the branches of the U, the branches of the U are twisted by turning the bent part of the U in the anticlockwise direction relative to the free ends of the branches.

[0012] For shaping the bristles of the brush the direction of rotation of the brush and the direction of rotation of a trimmer are reversed with respect to the usual direction of rotation.

[0013] The invention consists, apart from the arrangements expounded hereinabove, of a certain number of other arrangements which will be dealt with more fully later with regard to embodiments which are described with reference to the drawings appended hereto but which are in no way limiting.

[0014] FIG. 1 of these drawings is a diagram illustrating the making-up of the eyelashes with a brush in accordance with the prior art.

[0015] FIG. 2 is a diagram similar to that of FIG. 1 illustrating making-up with a brush in accordance with the invention.

[0016] FIGS. 3 and 4 are diagrams illustrating phases of manufacturing the core of a brush according to the invention.

[0017] FIG. 5 is a diagram illustrating the cutting of the bristles of the brush.

[0018] FIG. 6 is a diagrammatic view along the line VI—VI of FIG. 5.

[0019] FIG. 7 is a diagrammatic section illustrating the beginning of taking a brush according to the invention out of its mascara container.

[0020] FIG. 8 illustrates the passage of the brush according to the invention through the wringing device.

[0021] FIG. 9, finally, is a diagram of a variant embodiment of the brush.

[0022] Referring to FIG. 1 of the drawings, a diagram can be seen illustrating a making-up operation using a brush 100 of the prior art, carried by a wand 101. The eyelid P of the right eye is viewed from above. The user holds the wand 101 in her right hand forming an angle A between the axis of the wand and a line L parallel to the mean transverse line of the two eyes. The angle A is, in practice, of the order of 10 to 15°. In the conventional brush 100, the bristles 102 form layers 103 in a helix which, for an observer holding the brush 100 vertically in front of him/her, with its end pointing upwards, rise from right to left in the area lying between the observer and the axis of the brush.

[0023] With such an arrangement, as visible in FIG. 1, eyelashes C are practically aligned with the layers 103 of bristles of the brush. As a result blobs of mascara are deposited on the eyelashes without these being separated by brushing. The resulting make-up effect needs to be improved.

[0024] To do that, according to the invention, a mascara brush 1 includes a core 2 formed from a metal wire f bent into a U conventionally as illustrated in FIG. 3, the bristles

3 being arranged between the branches 4, 5 of the U, substantially perpendicularly to the plane of these branches 4 and 5. The said branches 4 and 5 are then twisted by turning to the left, that is to say in the anticlockwise direction, the bent-over end of the U with respect to the free ends of the branches. This twisting movement is illustrated by an arrow g in FIG. 3.

[0025] To show the turns obtained clearly, FIG. 4 represents the branches 4, 5 twisted partially, the turns not yet being substantially adjoining. When the core is finished, as illustrated in FIG. 2, the turns are practically adjoining, gripping the bristles 3 between them.

[0026] It appears from FIGS. 2 and 4 that the turns of the core 2, viewed along the axis X from the free ends of the branches 4, 5 which are intended to be fixed in the wand, turn in the clockwise direction about the axis X of the core when progressing from the free end of the branches 4, 5 towards the opposite end of the core. The bristles 3 of the brush form helical layers S rising from left to right in an area located between the core and an observer who holds the brush substantially vertical in front of him/her with its tip pointing upwards. To illustrate this direction of rise of the layers S clearly, the layers which are located to the front of the plane of the drawing have been represented in solid line, whereas those which are located to the rear of the plane have been represented in dashes.

[0027] The mean angle of inclination B of the layers S with respect to the axis of the core 2 depends on the pitch of the turns of the core 2.

[0028] With a brush 1 in accordance with the invention, in which the turns are reversed with respect to a conventional brush, during making-up, as illustrated in FIG. 2, the eyelashes C are offered up transversely to the layers S of bristles, which has the effect of depositing the make-up product more homogeneously, and above all, of separating the eyelashes C right from the start. With the same angle A of approximately 15°, the eyelashes C are at substantially 70° across the layers S for an angle B of approximately 35°.

[0029] The bristles 3, when they are placed between the branches 4, 5 of the U, as illustrated in FIG. 3, generally have the same length and their ends are aligned, the middle of the bristles being substantially on the axis of the core. As a result, after twisting the branches 4, 5, the envelope surface of the ends of the bristles is a cylindrical surface, axisymmetric about the axis X of the core. In general, the brush 1 is given a shape which is different from the cylindrical shape, for example a frustoconical shape tapered towards that end which is distant from the wand.

[0030] To do that, a trimmer 7 is used, for example of frustoconical shape, of axis parallel to that of the core, but pointing in the opposite direction. During the cutting operation, the brush 1 and the trimmer 7 are made to turn about their respective axis. Owing to the reversal of the direction of the turns, with respect to a conventional brush, the brush and the trimmer are made to rotate in a direction which is the reverse of that adopted for cutting a conventional brush.

[0031] The brush 1 generally includes, at that end of the wand 6 which is remote from the core 2, a stopper 8 (see FIGS. 7 and 8) equipped with an internal screw thread 9 for screwing onto the external screw thread 10 of the neck 11 of a container R containing the mascara. This neck 11 is

provided, internally, with a wringing device 12 generally consisting of a sort of washer made from a flexible material, particularly from an elastomeric material; the diameter of the internal orifice of the wringing device 12 is only slightly greater than that of the wand 6, so that passing through this wringing device 12 takes place with a certain resistance developed by the bristles 3, which must fold at least partially.

[0032] According to the invention, the turns of the core 2 of the brush and the layers S of bristles turn about the axis of the wand 6 in the same direction as the internal screw thread 9 of the stopper 8 and as the external screw thread 10 of the neck 11.

[0033] When the brush 1 is extracted from the container R, the user first of all exerts a rotational movement on the stopper 8 to unscrew it from the neck 11. This rotational movement takes place in an anticlockwise direction. When the stopper 8 is unscrewed, the user terminates the extraction by exerting a translational movement. In practice, this translational movement is accompanied by a rotational movement in the same direction as the one which caused the unscrewing of the stopper 8.

[0034] Owing to the fact that the layers S of the brush 1 turn in the same direction as the screw thread 9, the negotiation of the wringing device 12 by the layers S, which are given a rotational movement in the anticlockwise direction, corresponds to unscrewing the brush 1 with respect to the wringing device 12, which reduces the resistance offered by the bristles 3 when passing through the wringing device 12.

[0035] The bristles 3 of the brush, resisting the wringing device to a lesser extent, create less of a partial vacuum, and therefore less of a pressure effect during extraction. The product is better distributed along the bristles, and these smooth the product better along the eyelashes C.

[0036] The pitch of the turns of the core 2 may be chosen to be different from the pitch of the screw thread 9, to modulate the wringing through the wringing device 12.

[0037] Numerous variant embodiments of the brush 1 are possible. FIG. 9 illustrates a slightly different form of brush produced with bristles of larger cross-section and where a smaller number per turn is used. The brush may include an off-centred core.

[0038] The brush could include a mixture of bristles of different cross-sections. The bristles may include longitudinal capillary slits or grooves. The bristles may be tubular.

[0039] The transverse section of the bristles 3 may have different shapes: circular, oval, multilobed, rectangular, flat, etc.

[0040] The ends of the bristles may be jagged or include a bulge. The bristles may be formed from a mixture of relatively rigid bristles and more flexible bristles.

[0041] In the case of a mixture of bristles of different diameter, the bristles of large diameter may be longer or shorter than those of smaller diameter. The bristles are made of a conventional thermoplastic material such as polyamides, polyesters, polyether-block-amides or polytetrafluoroethylene. These thermoplastic materials may contain additives changing the wettability of these bristles or their slip

characteristics. These additives are chosen from among molybdenum sulphide, boron nitride, or the product marketed under the trade name "Teflon", fullerenes, graphite, talc or similar materials.

What is claimed is:

1. Make-up brush, particularly for applying mascara to the eyelashes, including a core formed from a metal wire bent into a U and the branches of which are twisted to trap radial bristles between them, the core being fixed to the end of a wand, characterized in that the branches (4, 5) of the core (2) are twisted, turning to the left, to form turns which, viewed along the axis (X) from that end of the core which is fixed in the wand, (6) turn in the clockwise direction about the axis of the core when progressing from the wand (6) towards the end of the brush, whereas the bristles (3) of the brush form helical layers (S) rising from left to right in the area located between the core (2) and an observer who holds the substantially vertical brush (1) in front of him/her with its tip pointing upwards.

2. Brush according to claim 1, characterized in that the angle of inclination (B) of the layers of bristles (S) with respect to the axis (X) of the brush is approximately 35°.

3. Brush according to claim 1 or 2, in which the wand (6) carrying the core includes, at its other end, distant from the core, a stopper (8) provided with a screw thread (9) for

screwing onto the neck (11) of a container (R) containing the mascara, this neck (11) being equipped with a wringing device (12) through which the brush passes when it is withdrawn from the container, characterized in that the branches (4, 5) of the core (2) of the brush are twisted to form turns turning in the same direction as the screw thread (9) of the stopper.

4. Brush according to claim 3, for which the direction of screwing of the stopper (8) relative to the container (11) is the clockwise direction, characterized in that the branches (4, 5) of the core (2) are twisted so that the turns turn in the clockwise direction about the axis (X) of the core, when progressing from that part of the core which is fixed in the wand towards the free end of the core.

5. Method for manufacturing a make-up brush, particularly for applying mascara to the eyelashes, according to which method, after having folded a metal wire (f) over into a U and after having placed bristles (3) between the branches (4, 5) of the U, the branches of the U are twisted, characterized in that, to twist the branches, the bent part of the U is turned in the anticlockwise direction (g) relative to the free ends of the branches (4, 5).

* * * * *