



US 20160256751A1

(19) **United States**

(12) **Patent Application Publication**
Barandao et al.

(10) **Pub. No.: US 2016/0256751 A1**

(43) **Pub. Date: Sep. 8, 2016**

(54) **SPORTS BALL COLLECTOR AND DISPENSER APPARATUS**

Publication Classification

(71) Applicants: **Mossa Barandao**, Washington, DC (US); **Miin-Jy Tsai**, Fairfax, VA (US)

(51) **Int. Cl.**
A63B 47/02 (2006.01)
A63B 47/00 (2006.01)

(72) Inventors: **Mossa Barandao**, Washington, DC (US); **Miin-Jy Tsai**, Fairfax, VA (US)

(52) **U.S. Cl.**
CPC *A63B 47/02* (2013.01); *A63B 47/002* (2013.01)

(21) Appl. No.: **15/063,508**

(57) **ABSTRACT**

(22) Filed: **Mar. 7, 2016**

A sporting ball collector and apparatus is provided to overcome undesirable issues in the existing ball-collector apparatuses. The disclosed apparatus is structured and configured to achieve, among many other advantages, a realizing of the pick-and-use type of ease to use, an obviating of any need for bending down when it comes to ball-collecting, and a rendering of the dispensing process easy and defined and the emptying process easy and controlled. The disclosed apparatus comprises a receptacle-collector part, a multi-purpose tray part and a handle-bracket part.

Related U.S. Application Data

(60) Provisional application No. 62/129,013, filed on Mar. 5, 2015.

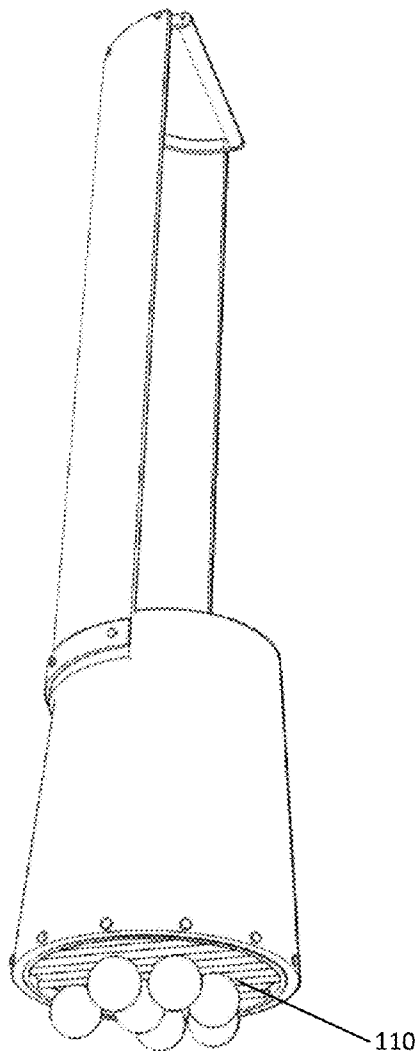

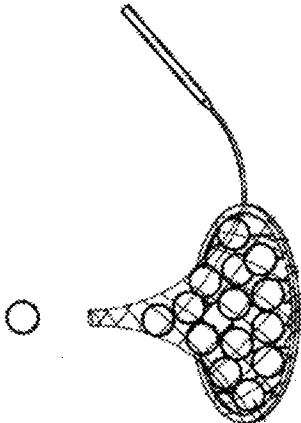

FIG. 1A
(Related Art)

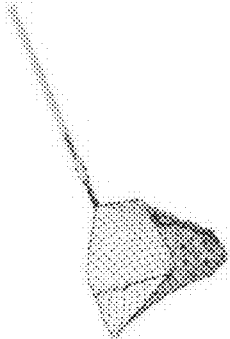

FIG. 1B
(Related Art)

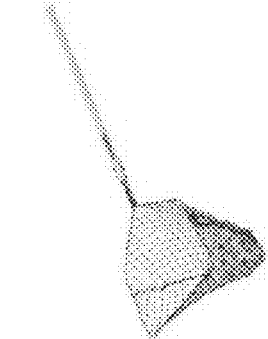

FIG. 1C
(Related Art)

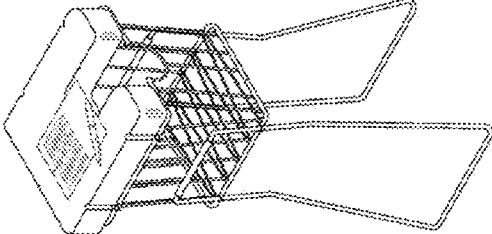

FIG. 1D
(Related Art)

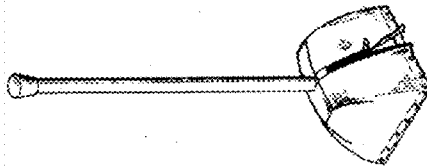

FIG. 1E
(Related Art)

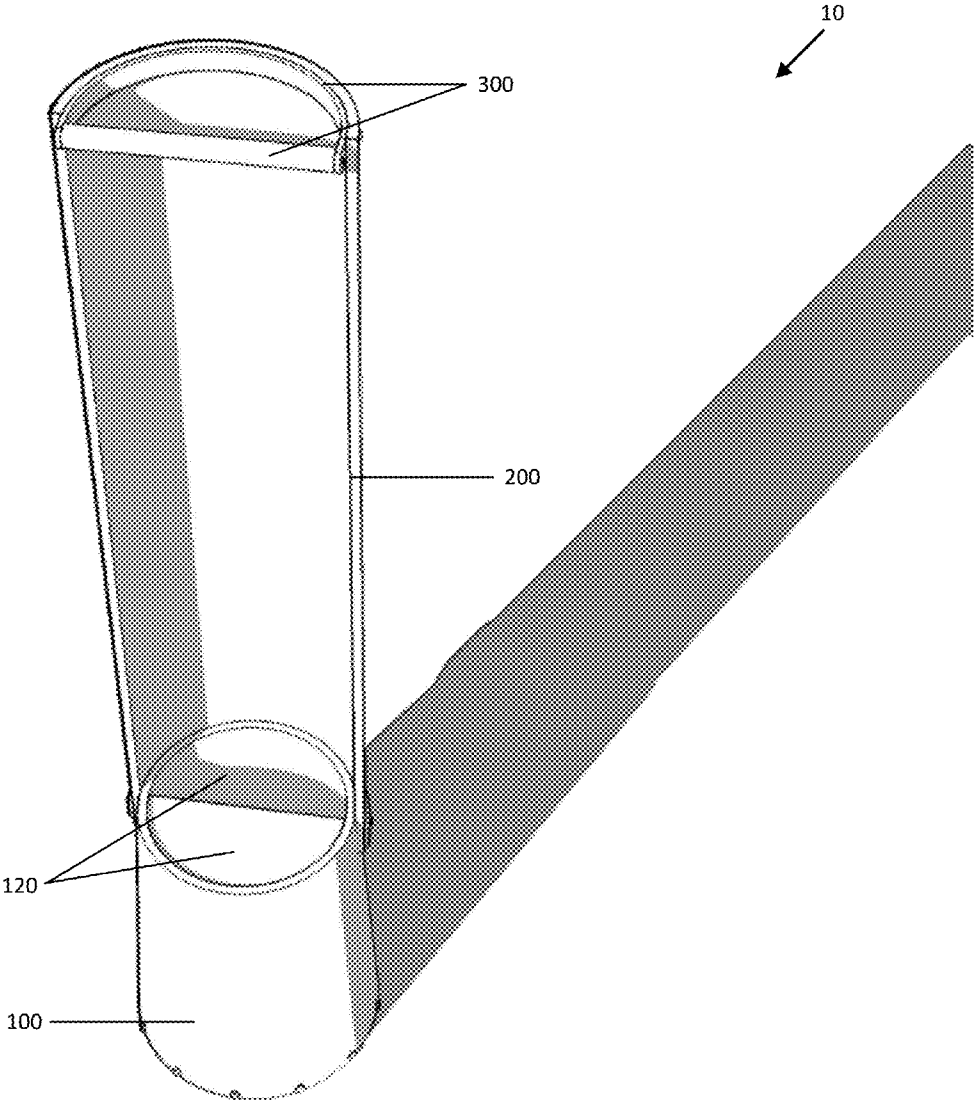

FIG. 2A

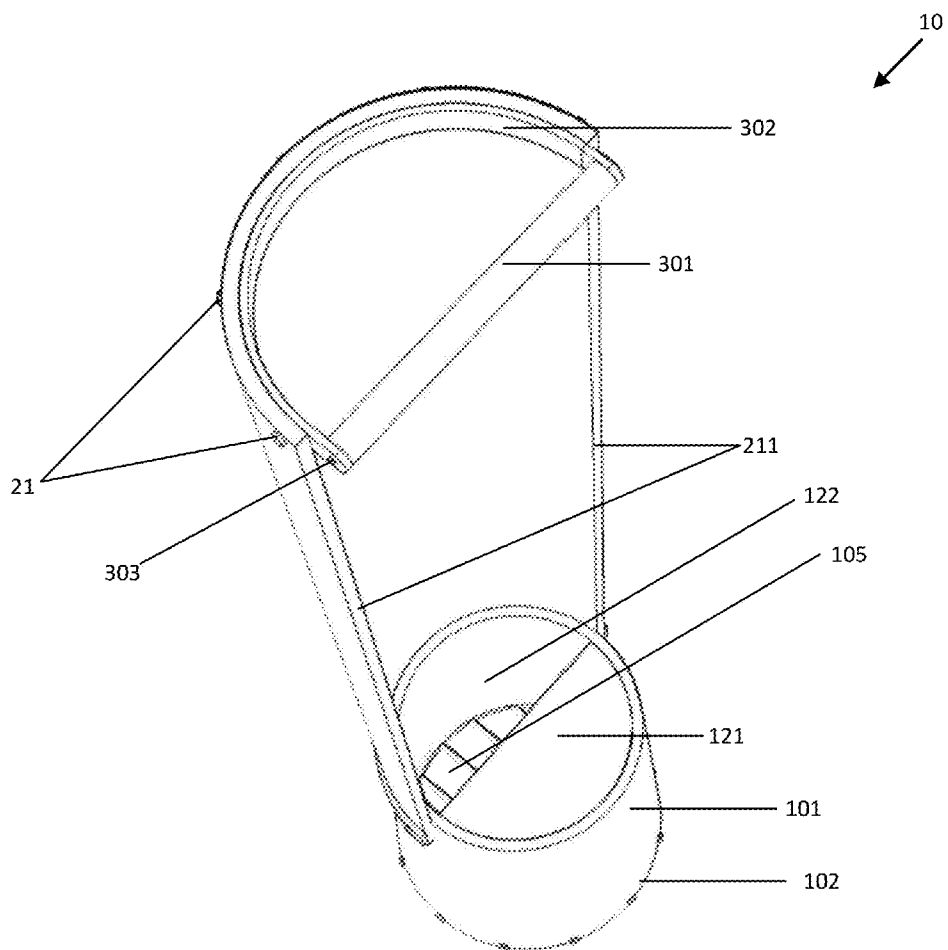

FIG. 2B

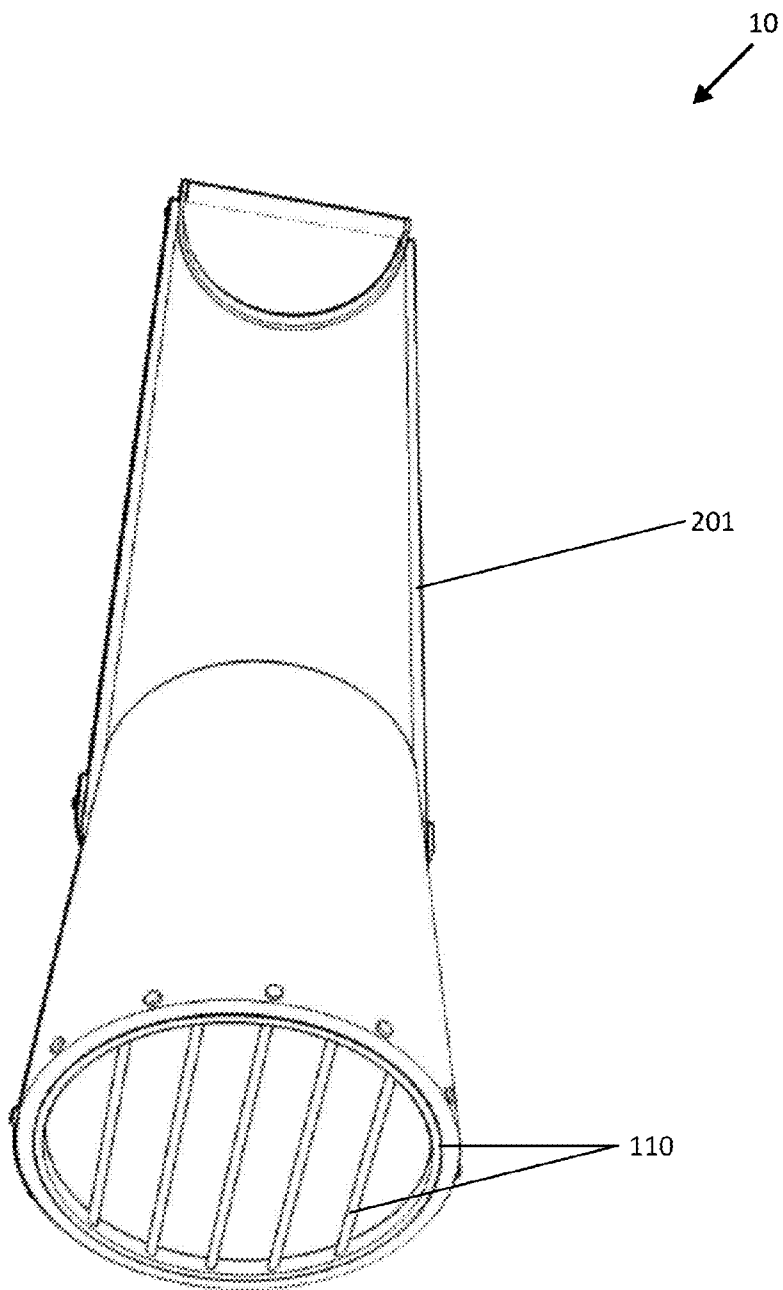

FIG. 2C

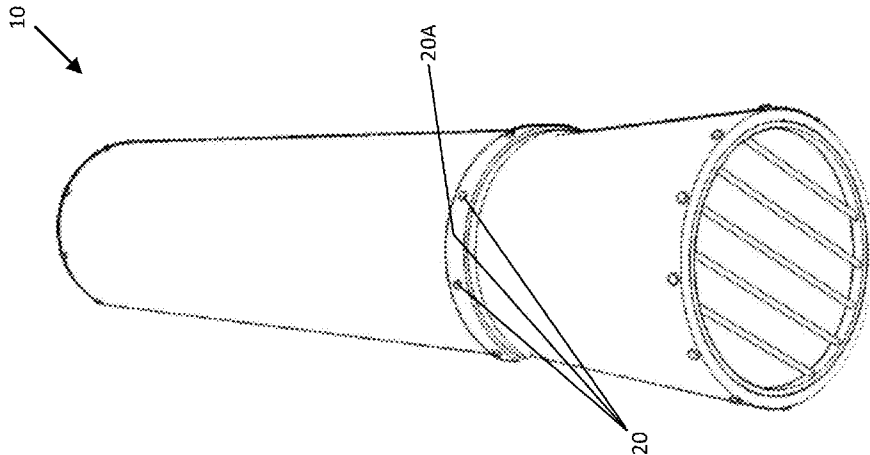

FIG. 2E

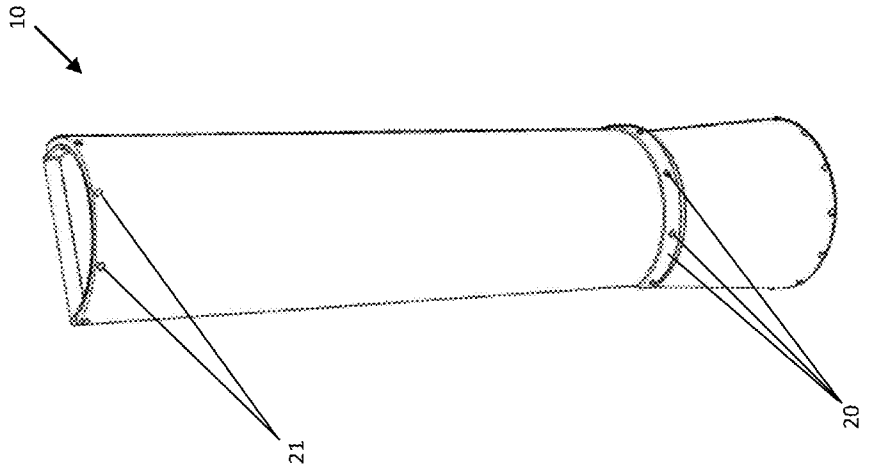

FIG. 2D

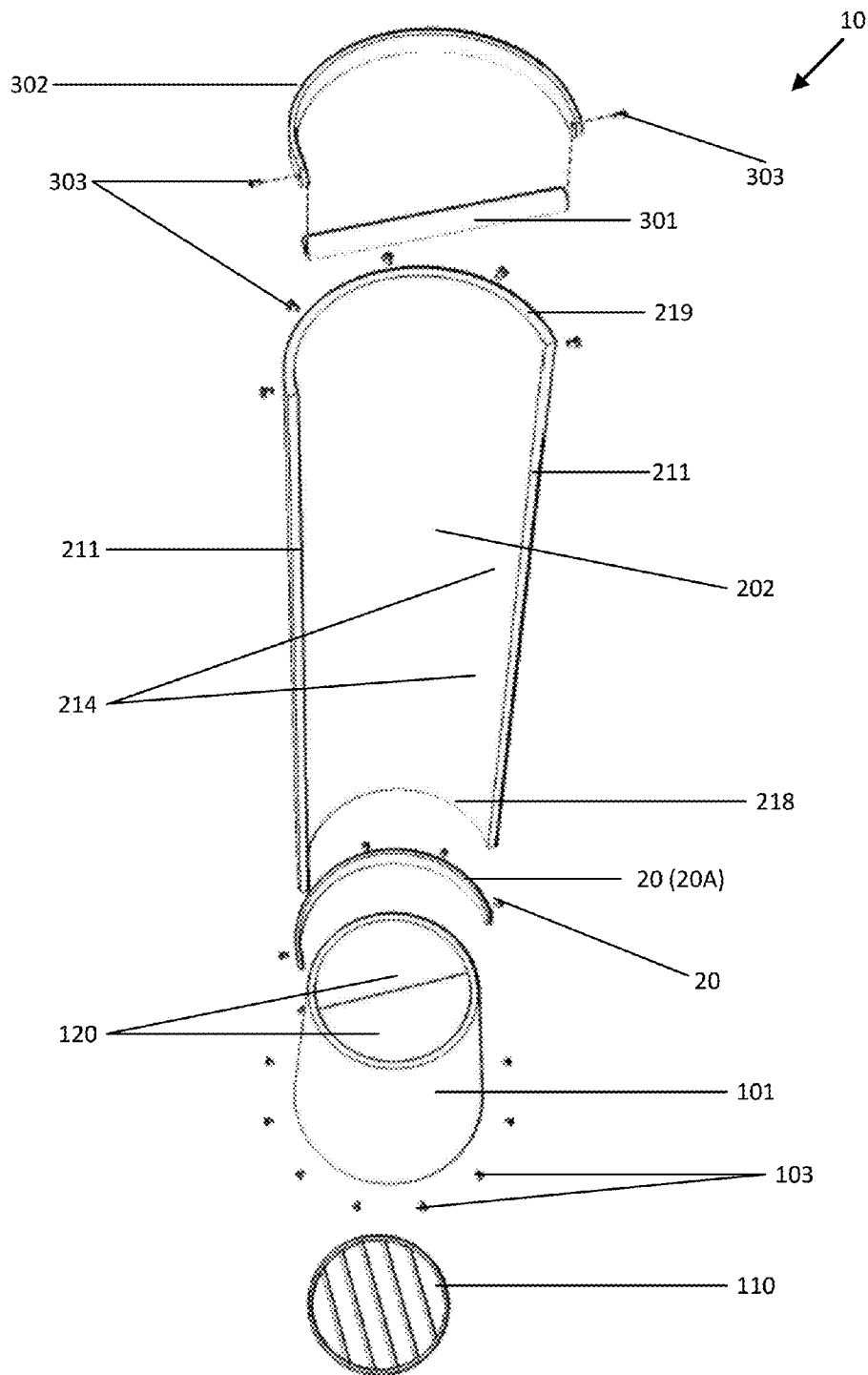

FIG. 3

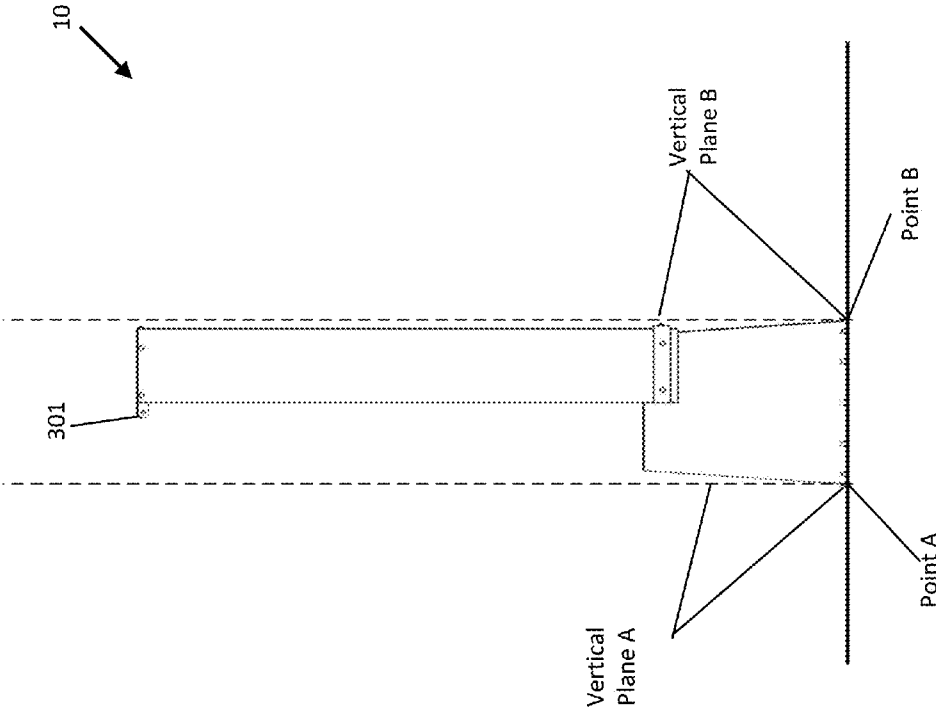

FIG. 4B

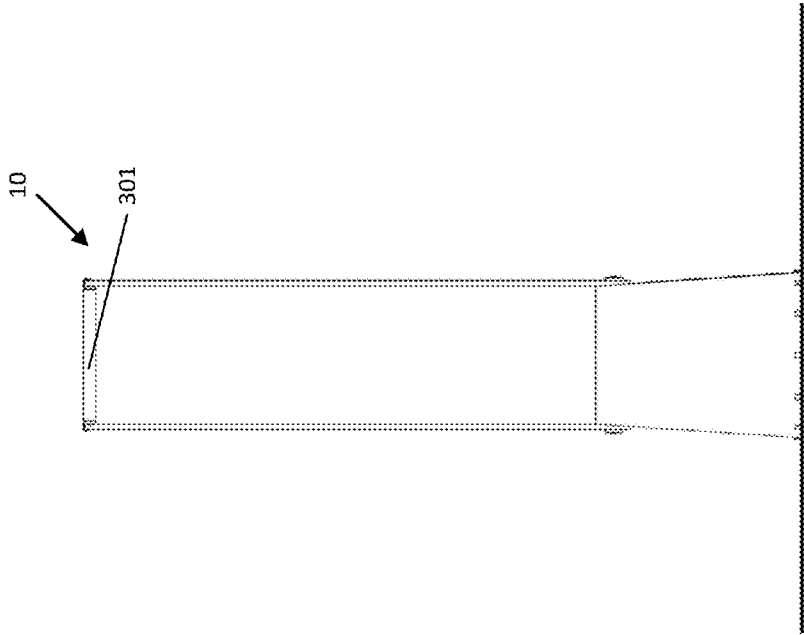

FIG. 4A

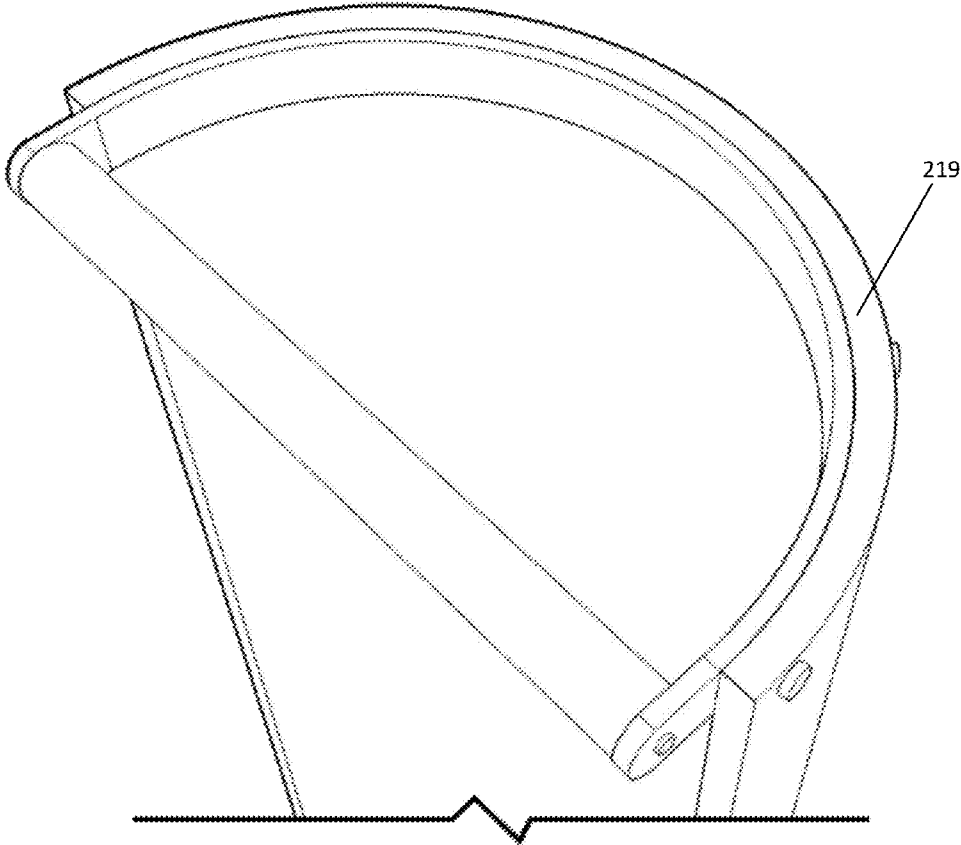

FIG. 5A

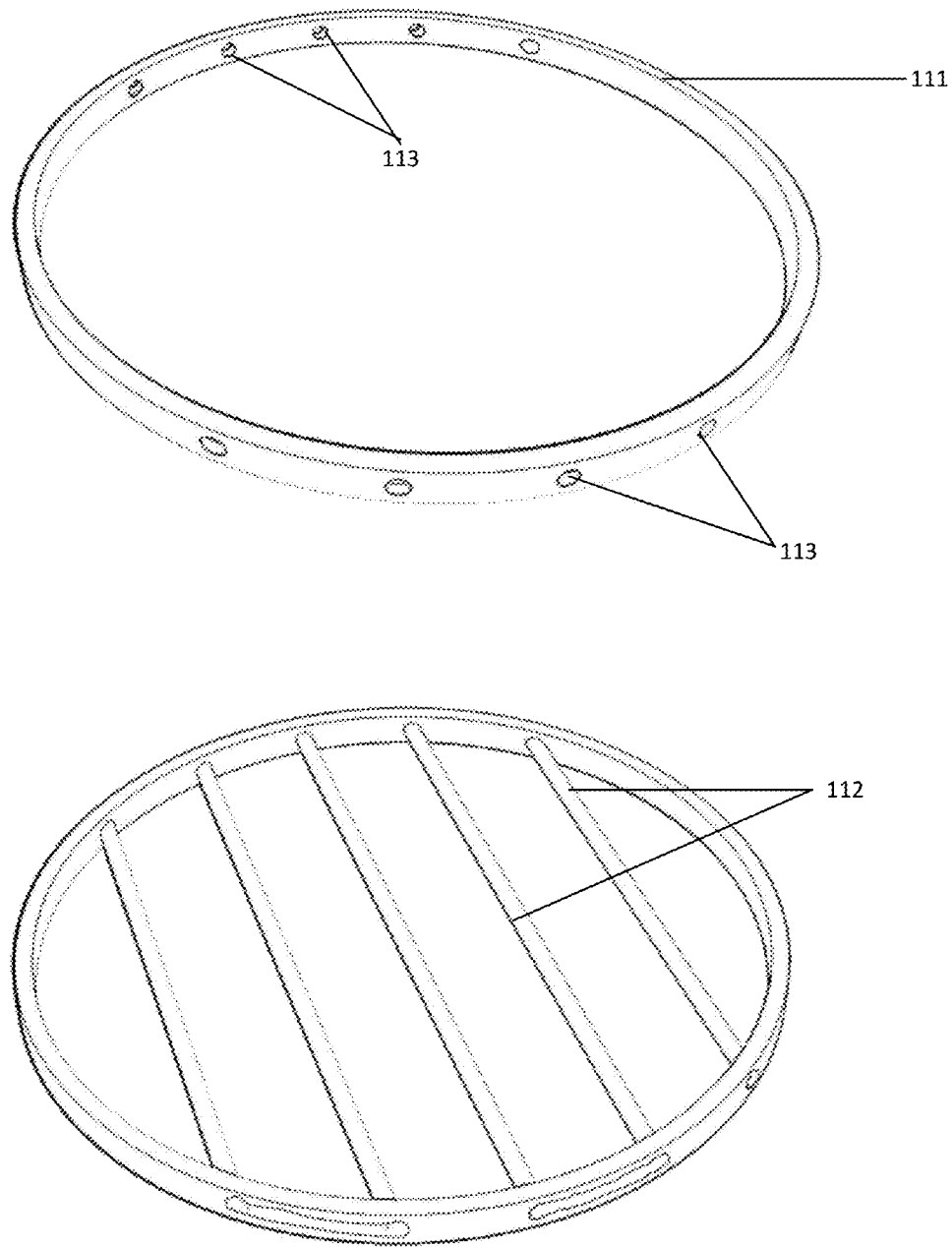

FIG. 5B

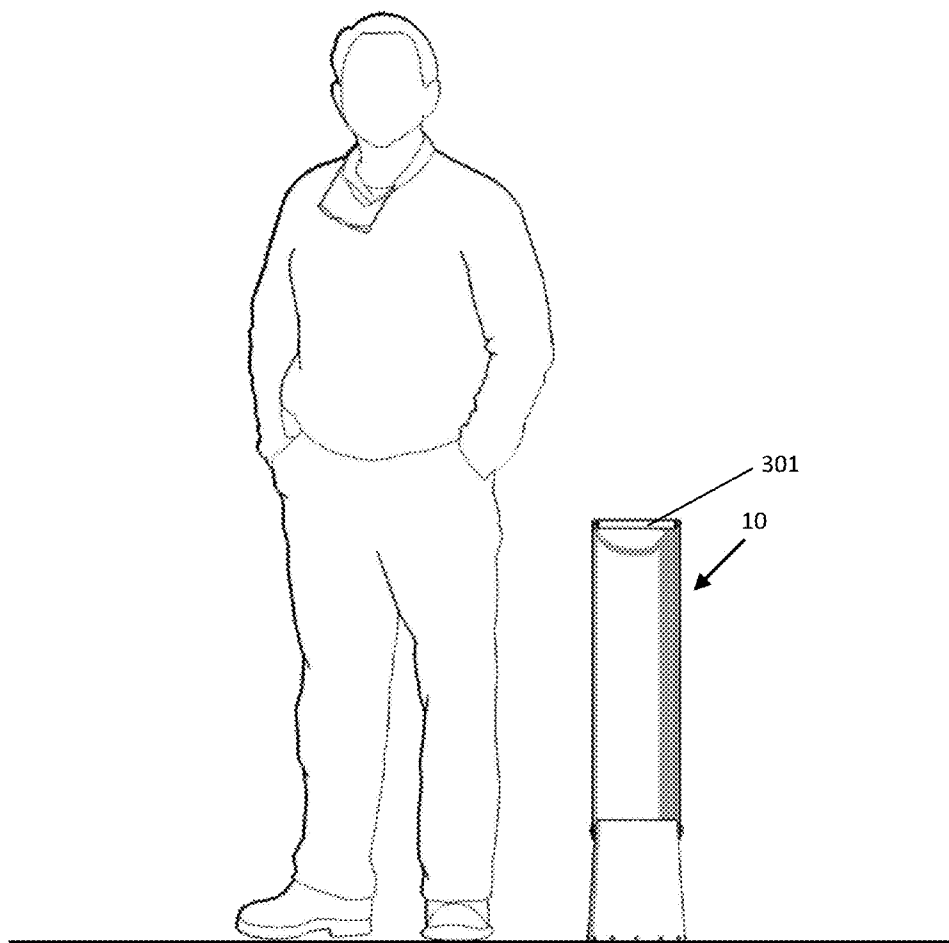

FIG. 6A

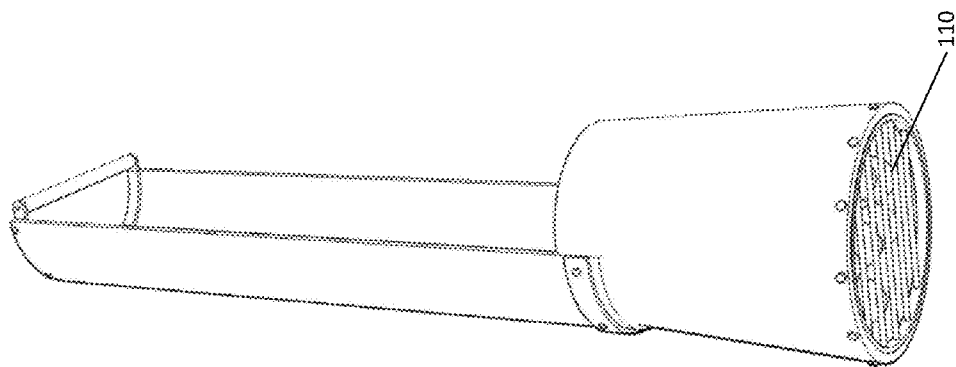

FIG. 6C

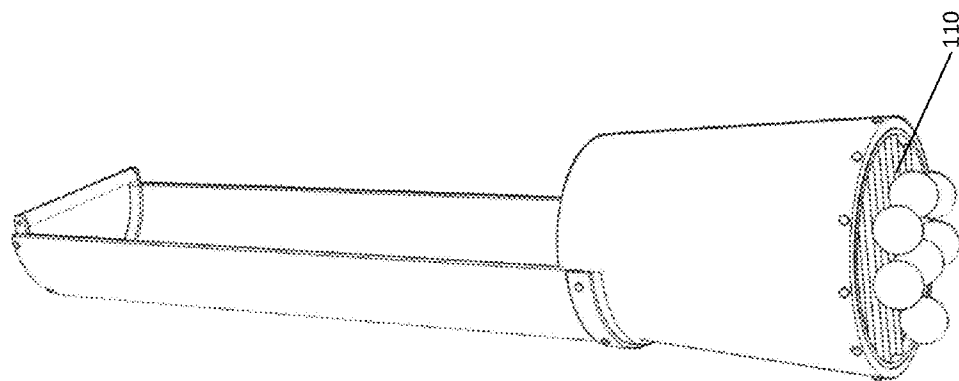

FIG. 6B

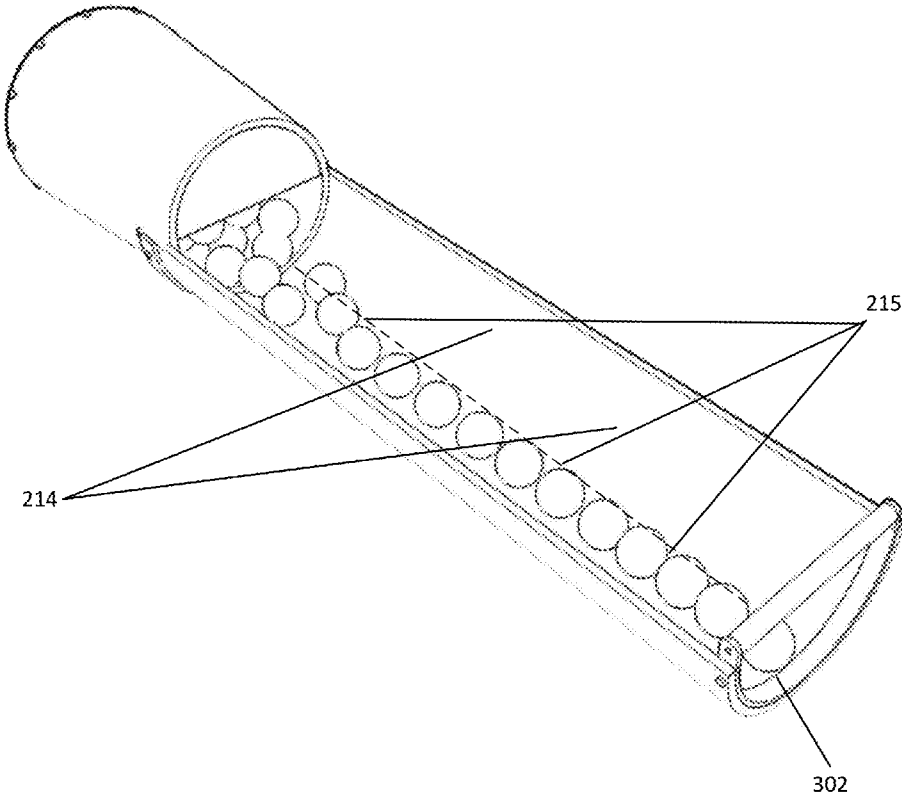

FIG. 7A

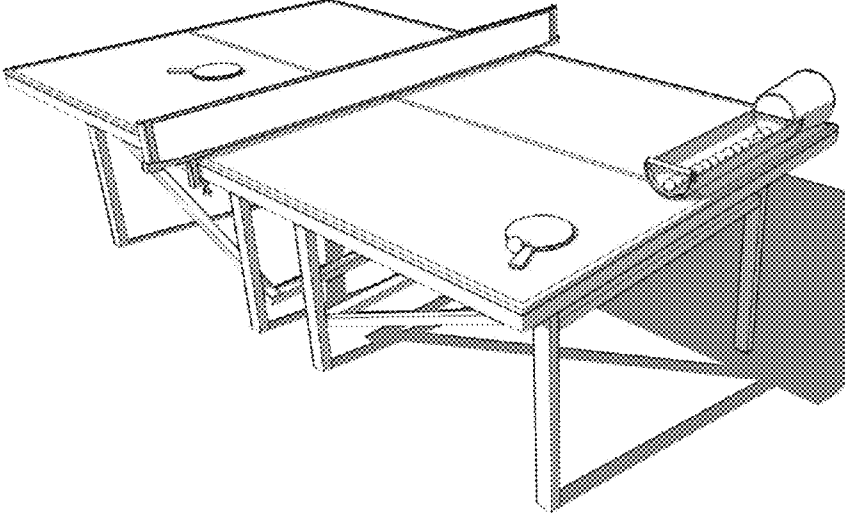

FIG. 7B

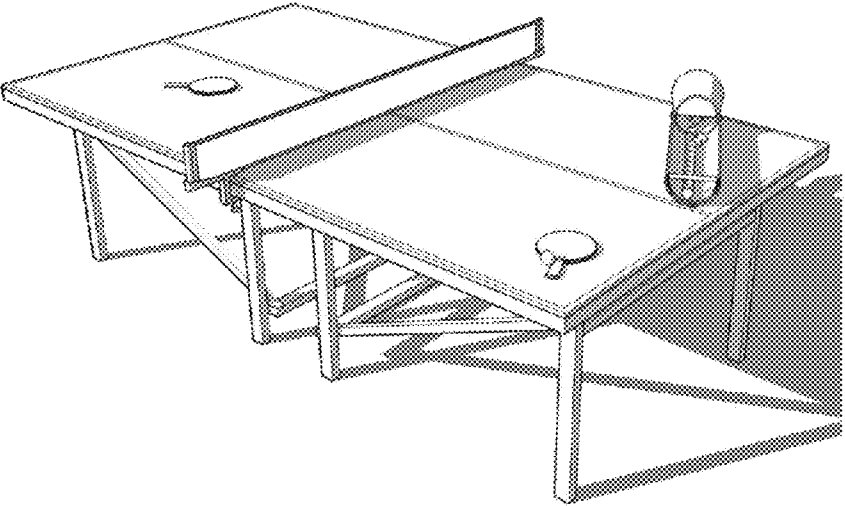

FIG. 7C

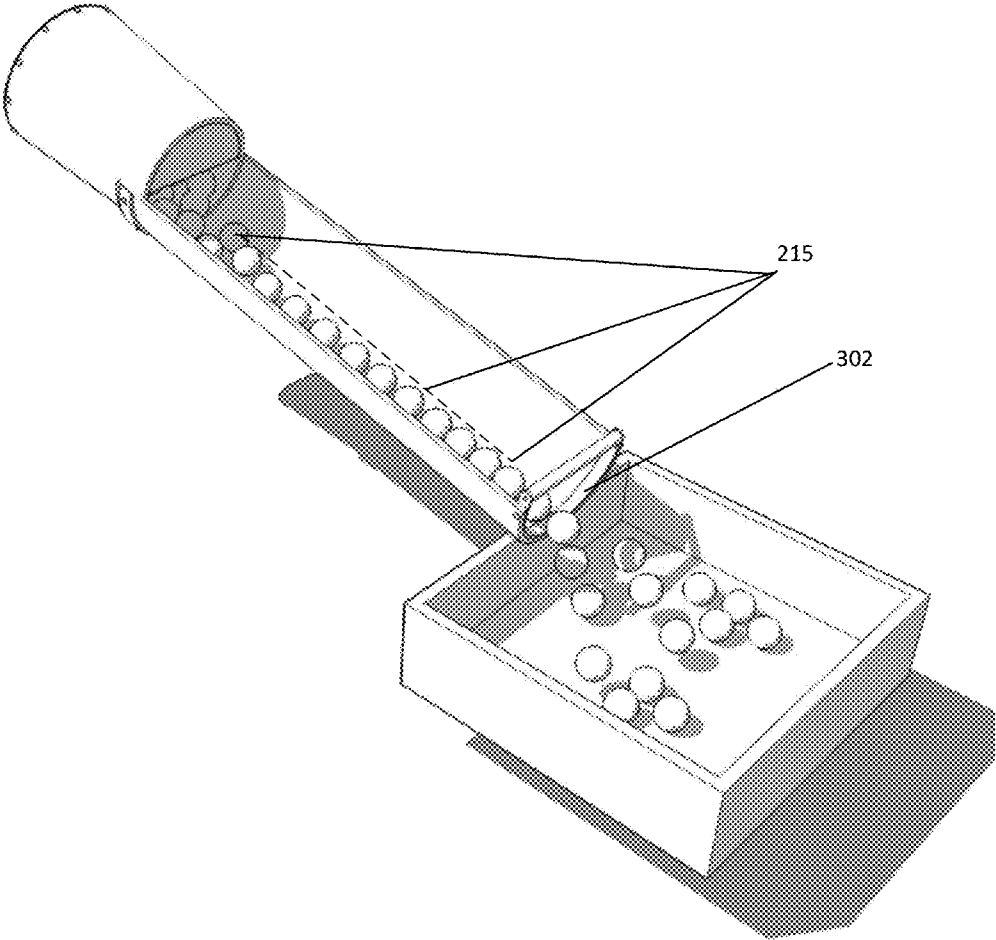

FIG. 8

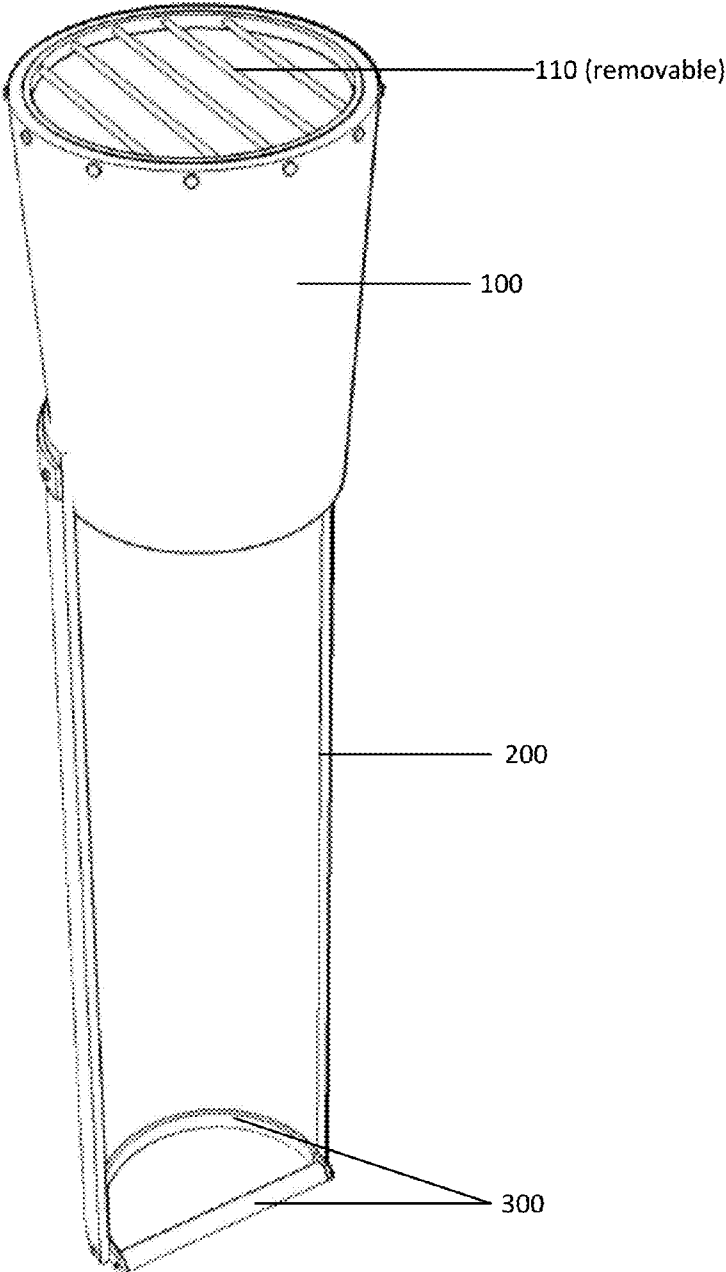

FIG. 9A

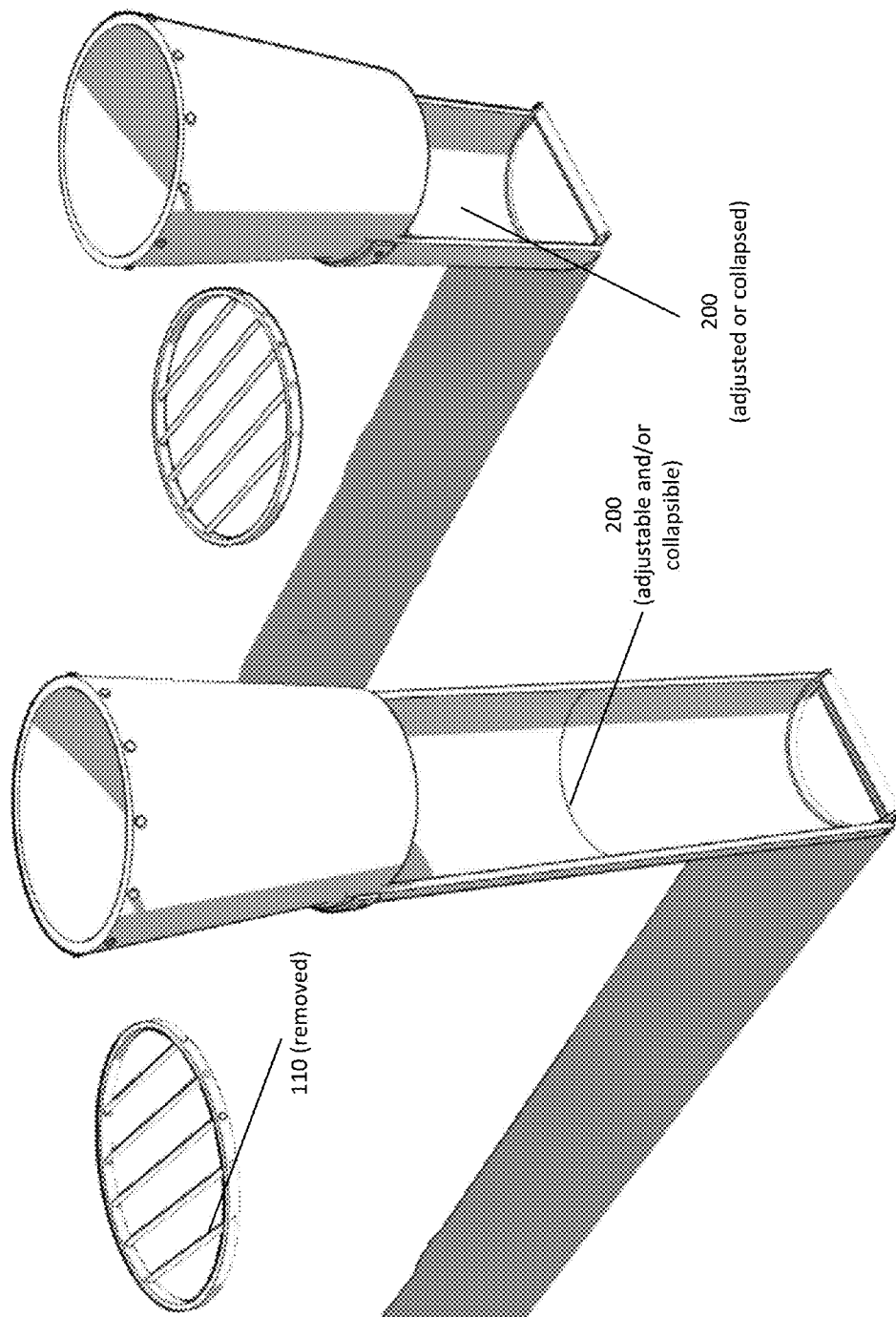

FIG. 9B

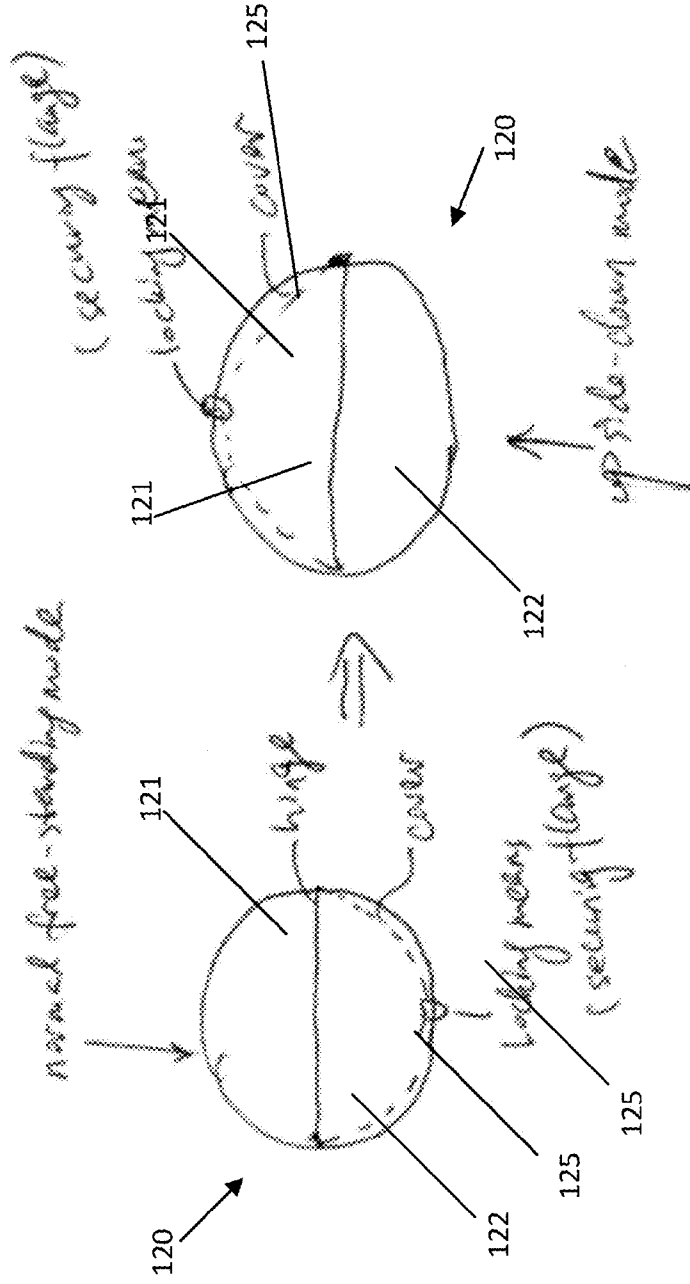

FIG. 9C

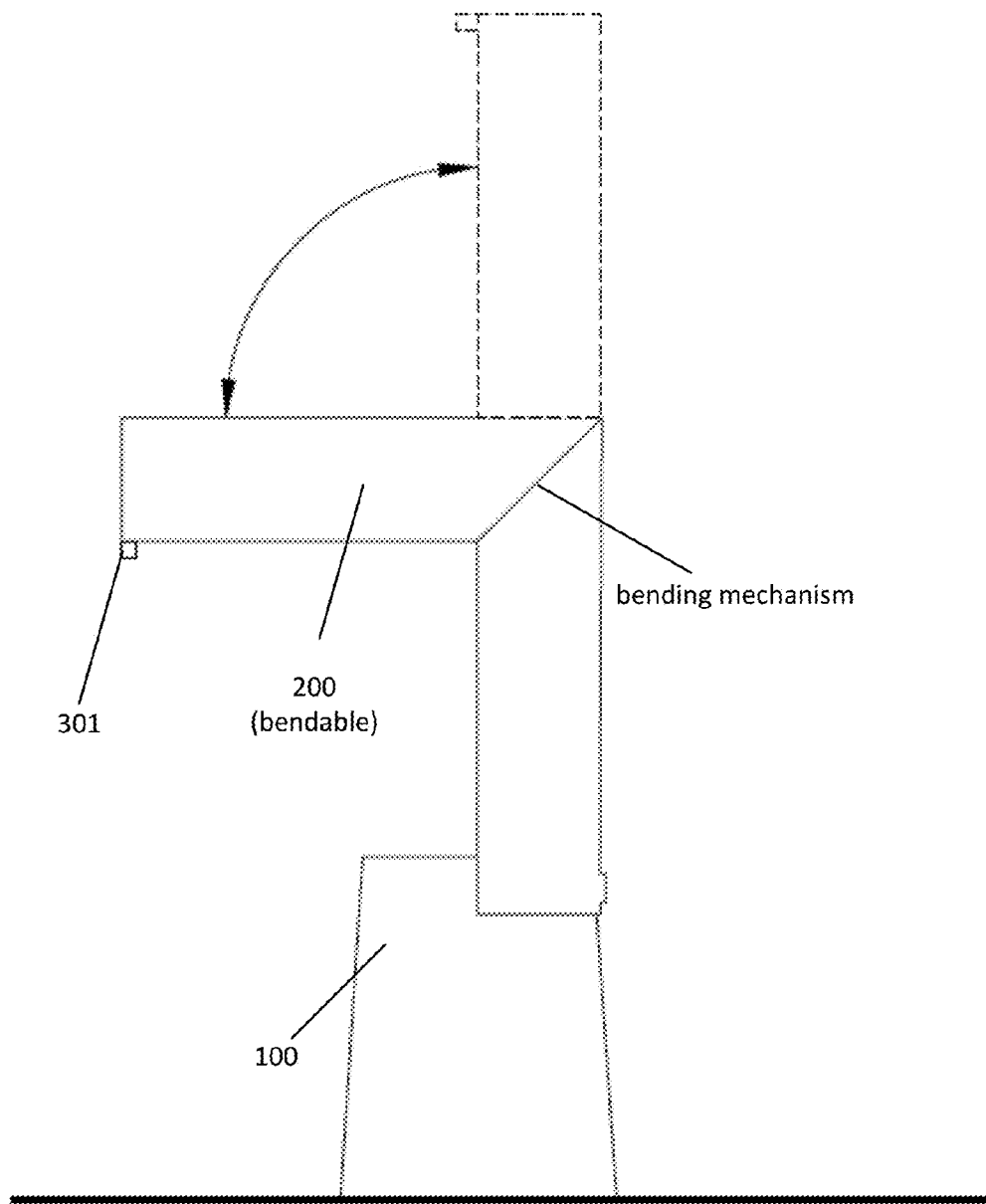

FIG. 10

SPORTS BALL COLLECTOR AND DISPENSER APPARATUS

CROSS-REFERENCE TO RELATED APPLICATION

[0001] This application claims the benefit under 35 U.S.C. §119(e) of Provisional Patent Application No. 62/129,013, filed Mar. 5, 2015, the entire disclosure of which is hereby incorporated by reference.

BACKGROUND

[0002] 1. Technical Field

[0003] The present disclosure generally relates to a sports ball collector apparatus. More particularly, the present disclosure relates to a light-weight and durable sports ball collector apparatus which is easy-to-operate and pretty much stress-and-discomfort-free when it comes to collecting sports balls scattered on a ground or floor as the apparatus does not require a user to bend the user’s back during the collecting operation, and which can be quickly, easily and conveniently turned into a ball-dispenser or ball-emptier without any need for the user to go through steps that may incur stress, difficulty or inconvenience.

[0004] 2. Description of the Related Art

[0005] There are quite a few different types of sports ball collector apparatuses that have been on the market or have been invented. FIGS. 1A-E illustrate several different such sports ball collector apparatuses.

[0006] As used herein, “sports ball” and “ball” may be used interchangeably to refer to a sports ball of a limited size and weight which may be easily scattered around a ground-level or floor-level area (e.g., a floor, a ground, a field, a course, and etc.) during a playing session of a corresponding sport. Examples of a sports ball include a table-tennis ball (which may also be called “ping-pong ball”), a golf ball, a tennis ball, and etc. As used herein, a floor, a ground, a field, a course, and other similar terms, may be used interchangeably to refer to a ground-level or floor-level area of a size considered limited with respect to the corresponding sport in which a sports ball is used or featured during a playing session thereof.

[0007] FIG. 1A shows a tube-based ball collector apparatus that have been available on the market. A ball collector of this tub-based design (type) or similar design (type) suffers several weaknesses. First, its single-tube design makes it impossible for the ball collector to collect more than one ball at a time. Second, bending down is required to pick up a ball collector of this type when the ball collector is resting on the floor, as the ball collector cannot stand alone, and thus requires a supporting wall, a column, or a flat surface to rest (lean or lie) against, thereby causing repeated physical stresses and strains onto the user every time the user needs to bend lower his/her back to reach for the ball collector. Also, the nature of not being able to stand alone, which is apparently caused by its lacking of sustainable center of activity to support its entire structure, also renders a ball collector of this type unsuitable to be a storage unit even though such a ball collector can collect and hold around 23 balls. Third, when it comes to collecting balls scattered across a floor in a heavy usage environment, a ball collector of this or similar type can only picks up one ball at a time and requires proper aligning of its tube nozzle over an aimed ball and applying a downward force or pressure to cause to the aimed ball to enter and be retained inside the single tube. Thus, the ball-collecting pro-

cess is rather inefficient, slow, and requires a high level of steady hand eye coordination, which can be stressful for many users. Fourth, when it comes to dispensing and emptying collected balls, a ball collector of this type only allows one ball at a time to exit one end of the single tube, thereby rendering a dispensing or emptying process relatively unsmooth inefficient, and relatively slow. Also, for sports like table-tennis or tennis, there is no convenient way for the user to reach the inside of the single-tube for a retained ball, thereby not being able to function as a “serve practice buddy” to facilitate the training of serving (which may be considered one of the most important area of sports like table-tennis or tennis).

[0008] FIG. 1B shows a scooper-net-based collector apparatus that have been available on the market, a ball collector of this or similar type suffers a few weaknesses similar to the weakness associated with a ball collector of the tube-based design discussed above. Briefly, bending down is once again required to pick up a ball collector of this type when the ball collector is resting on the floor, as the ball collector cannot stand alone due to its lacking of a solid base. The repeated motions of bending down inevitably causes stress and discomfort onto the user. Due to this nature of not being able to stand alone by itself, a ball collector of this type is not suitable to be an effective storage unit. Further, when it comes to collecting scattered balls, a good net-scooping motion and technique (with the long handle which extends laterally away from the net) is required, lacking of which would often causes aimed balls being pushed away from the ball collector. Also, when the net is close to two-thirds (2/3) of its capacity, continuous scooping motion used to collect more balls becomes less and less efficient as the scooping motion tends to send balls already in the net flying out. These limitations render the ball-collecting process rather inefficient, slow and difficult for many users. Also, repeated scooping can quickly wear out the frame of the netting and compromise its structural integrity, thus making the ball collector less durable. When it comes to emptying collected balls, a ball collector of this or similar type has not predefined path or channel for emptying collected balls (usually into a container placed there-beneath). Specifically, the emptying is usually achieved by first having one hand on the handle and another hand pulling the bottom of the net to form a funnel-like shape and then inverting the “funnel”, which doe cause the collected balls to be emptied but in such a highly scattered or unordered manner that a good portion of collected balls can miss the beneath container and fall and become scattered on the floor.

[0009] FIG. 1C shows a sports ball collector and dispenser apparatus disclosed in U.S. Pat. No. 8,534,726 to Bulatao. The entire disclosure of the ’726 patent to Bulatao is hereby incorporated by reference. Briefly, Bulatao’s apparatus incorporates a well-known ball-collector frame generally involving the use of a set of parallel spaced-apart elastic members or a grid of spaced-apart elastic members each biased to its respective original position with adjacent elastic members spaced slightly smaller than the diameter of a sports ball of a particular type (such as a table-tennis ball). When a downward force or pressured is exerted on or otherwise received by the ball-collector frame (which is usually situated at the bottom of a frame) while ball-collector device is over one or multiple sports balls, elastic members expand to make respective spaces there-between larger than the diameter of the aimed sports balls, thus allowing the sports balls to be retained above the elastic members of the ball-collector

frame. Hereinafter, a ball-collector frame of this nature—namely, involving the generic use of space-apart elastic members to capture balls on the floor and retain captured balls above the elastic members—will be simply referred to as “elastic-member-based ball-collecting frame”. Bulatao’s ball-collector apparatus—which is mostly superior to ball-collectors of types shown in FIGS. 1A and 1B in terms of ball-collecting—however, also suffers a few drawbacks.

[0010] First, Bulatao’s ball-collector apparatus uses an elongated bar handle that laterally extends away from the ball-collector frame. This causes Bulatao’s apparatus to be not capable of standing alone with its elongated bar handle disposed and extended in its upright direction, since this elongated bar handle design, when paired with its away-situated ball-collector frame, simply lacks a center of gravity to support the elongated bar handle to stand in its upright direction. In fact, even if there is a wall or column which the elongated bar handle can lean against in its upright direction, the leaning is largely unreliable and unstable, causing the elongated bar handle to eventually fall from its upright direction to its natural generally lateral direction. As such, bending down is still mostly required to pick up Bulatao’s ball-collector apparatus (as the ball-collector apparatus usually ends up resting on the floor in its natural lateral resting position with the ball-collector frame sitting on the floor and the elongated bar handle extending laterally away from the ball-collector frame). Such a bending down to pick up the ball-collector apparatus, when repeated times after times, can, as discussed above in connection with the ball collectors shown in FIGS. 1A and 1B, cause physical stress, strains and discomfort onto the user.

[0011] Second, Bulatao’s elongated bar handle design, when paired with its away-situated ball-collector frame, may present some safety challenges. Briefly, its elongated bar handle extending away from the ball-collector frame essentially causes the elongated bar handle to protrude across the floor at a relatively low height, which can easily cause a passer-by (not aware of the handle situated beneath him/her) to be tripped when a Bulatao’s apparatus is resting on the floor in its natural resting position of its ball-collector frame resting on the floor.

[0012] Third, when it comes to collecting balls scattered on the floor, Bulatao’s elongated bar handle design, when paired with its away-situated ball-collector frame, requires an exertion of additional force or pressure from the user via the elongated bar handle, when compared to a ball-collector apparatus with a same or similar bottom-level ball-collector frame but with a handle immediately and directly elevated above the ball-collector frame, due to apparent physics principles, thereby making the capturing of scattered balls with its ball-collector frame more difficult and less efficient for a user. Also, the use of its elongated bar handle requires lowering of a user’s hands, and therefore body frame, which causes more stress and discomfort onto the user.

[0013] Fourth, when it comes to dispensing or emptying collected balls (contained in the ball-container receptacle above the elastic-members-based ball-collector frame), due to its tapered and relatively narrow dispensing end, a user has to squeeze on the dispensing end to make collected balls to be dispensed one ball at a time, especially causing the operation of getting the last few contained balls to become rather difficult and inconvenient. In addition, due to its tapered and relatively narrow dispensing end, it is also difficult for a user to reach a ball contained inside the ball-container receptacle,

a characteristics which makes a Bulatao’s apparatus unsuitable to be a serve practice buddy. Further, Bulatao’s apparatus simply lacks a rather smooth and fast way of emptying collected balls (contained in the ball-container receptacle) into a container lying beneath the apparatus.

[0014] FIG. 1D shows a sports ball collector and dispenser apparatus disclosed in US Pat. Publication No. 20100278626 to Beavin. The entire disclosure of the ’626 published patent application to Beavin is hereby incorporated by reference. Briefly, although Beavin’s apparatus also employs an elastic-members-based ball-collector frame and a handle (for exerting downward force or pressure on the ball-collector frame) which may be held during a ball-collecting process without requiring a user to bend down, Beavin’s device also suffers a few drawbacks.

[0015] First, Beavin’s design still requires some transformation before the handle (for exerting downward force or pressure on the ball-collector frame) can be formed. As such, Beavin’s apparatus is not a “pick-and-use” type of conveniently accessible ball-collector apparatus. Second, Beavin’s apparatus requires a relatively oversize design, since the apparatus is designed to transform a collector apparatus into a seat where an adult user of a reasonable weight can sit. As such, Beavin’s apparatus most likely requires a steel frame, and is inevitably relatively bigger and heavier (compared to a typical ball-collector apparatus), which is not convenient and optimal for a user to carry the apparatus as the user moves around to collect balls scattered on the floor, ground or field. Third, the handle, when not used for exerting downward force or pressure on the ball-collector frame to collect scattered balls, is designed to be also used as two legs in the seating mode, which can weaken and wear out the handle (formed of the two legs) over a relatively shorter passage of time (compared to a ball-collector apparatus which does not require such a dual use of the grabbing handle). Fourth, when it comes to the process of emptying the collected balls into a container (typically lying underneath its ball-container receptacle), Beavin’s apparatus requires the user to go through a series of transformation steps, such as, e.g., retracting the two legs (which can be doubly used to form the grabbing handle for ball-collecting). Besides, there is no defined path way for the otherwise retained balls (retained in the ball-container receptacle) to exit the ball-container receptacle, and as a result, the retained balls may flow out of the receptacle scattered without order, which, similar to the emptying process of the net-scooper apparatus shown in FIG. 1B, may cause a few otherwise retained balls miss the beneath container and fall and become scattered on the floor or on the field.

[0016] FIG. 1E shows a sports ball collector apparatus disclosed in U.S. Pat. No. 3,982, 781 to Tucker et al. The entire disclosure of the ’781 patent to Tucker et al. (hereinafter simply referred to as “Tucker”) is hereby incorporated by reference. Briefly, although Tucker’s apparatus also employs an elastic-members-based ball-collector frame and a handle (for exerting downward force or pressure on the ball-collector frame) which may be held during a ball-collecting process without requiring a user to bend down, the handle of Tucker’s apparatus nonetheless has no other meaningful use. Thus, when it comes to the ball-dispensing and the ball-emptying processes, a user has to bend down to reach the ball-container receptacle immediately above the ball-collector frame, unzip a zip lock, and let the balls retained in the ball-container receptacle roll out, which renders either process inconvenient

to carry out and which certainly renders Tucker's apparatus unsuitable to be a serve practice buddy.

[0017] Thus, there is a need to have a lightweight and durable ball collector and dispenser apparatus which can overcome the above-discussed undesirable issues in the existing ball-collector apparatuses, an apparatus which can achieve, among many other advantages, a realizing of the pick-and-use type of ease to use, an obviating of any need for bending down when it comes to ball-collecting, a rendering of the dispensing process easy and defined (controlled) and the emptying process easy and controlled (defined).

BRIEF SUMMARY

[0018] The present disclosure provides a lightweight and durable ball collector and dispenser apparatus which overcomes the above-discussed undesirable issues in the existing ball-collector apparatuses. The disclosed apparatus is structured and configured to achieve, among many other advantages, a realizing of the pick-and-use type of ease to use, an obviating of any need for bending down when it comes to ball-collecting, and a rendering of the dispensing process easy and defined (controlled) and the emptying process easy and controlled (defined).

[0019] The above summary contains simplifications, generalizations and omissions of detail and is not intended as a comprehensive description of the claimed subject matter but, rather, is intended to provide a brief overview of some of the functionality associated therewith. Other systems, methods, functionality, features and advantages of the claimed subject matter will be or will become apparent to one with skill in the art upon examination of the following figures and detailed written description.

BRIEF DESCRIPTION OF THE DRAWINGS

[0020] The description of the illustrative embodiments can be read in conjunction with the accompanying figures. It will be appreciated that for simplicity and clarity of illustration, elements illustrated in the figures have not necessarily been drawn to scale. For example, the dimensions of some of the elements may be exaggerated relative to other elements. Embodiments incorporating teachings of the present disclosure are shown and described with respect to the figures presented herein, in which:

[0021] FIGS. 1A-E are a set of figures showing sports ball collector and dispenser apparatuses in the related art, which are provided to help understand the novel, inventive and advantageous aspects of the disclosed sports ball collector and dispenser apparatus.

[0022] FIGS. 2A-E are a set of perspective views illustrating one example of the disclosed sports ball collector and dispenser apparatus, according to one or more embodiments of the present disclosure.

[0023] FIG. 3 is an exploded view illustrating exemplary components of the disclosed sports ball collector and dispenser apparatus, according to one or more embodiments of the present disclosure.

[0024] FIGS. 4A-B are elevation views illustrating one example of the disclosed sports ball collector and dispenser apparatus, according to one or more embodiments of the present disclosure.

[0025] FIGS. 5A-B are sectional and component views illustrating exemplary configurations of selected individual sections and components of the disclosed sports ball collector

and dispenser apparatus, according to one or more embodiments of the present disclosure.

[0026] FIGS. 6A-C are views collectively illustrating an exemplary operation of collecting sports balls using the disclosed sports ball collector and dispenser apparatus, according to one or more embodiments of the present disclosure.

[0027] FIGS. 7A-B are views collectively illustrating an exemplary operation of dispensing collected sports balls using the disclosed sports ball collector and dispenser apparatus, according to one or more embodiments of the present disclosure.

[0028] FIG. 8 is a perspective view illustrating an exemplary operation of emptying collected sports balls into a storage container using the disclosed sports ball collector and dispenser apparatus, according to one or more embodiments of the present disclosure.

[0029] FIGS. 9A-C are perspective and component views illustrating an exemplary use of the disclosed sports ball collector and dispenser apparatus as well as different alternative configurations thereof providing expanded desirable functions, according to one or more embodiments of the present disclosure.

[0030] FIG. 10 is a simplified elevation view illustrating an exemplary use of the disclosed sports ball collector and dispenser apparatus with one or more alternative configurations thereof, according to one or more embodiments of the present disclosure.

DETAILED DESCRIPTION

[0031] In the following detailed description of exemplary embodiments of the disclosure, specific exemplary embodiments in which the disclosure may be practiced are described in sufficient detail to enable those skilled in the art to practice the disclosed embodiments. For example, specific details such as specific method orders, structures, elements, and connections have been presented herein. However, it is to be understood that the specific details presented need not be utilized to practice embodiments of the present disclosure. The following detailed description is, therefore, not to be taken in a limiting sense, and the scope of the present disclosure is defined by the appended claims and equivalents thereof.

[0032] References within the specification to "one embodiment," "an embodiment," "embodiments", and "one or more embodiments" are intended to indicate that a particular feature, structure, or characteristic described in connection with the embodiment is included in at least one embodiment of the present disclosure. The appearance of such phrases in various places within the specification are not necessarily all referring to the same embodiment, nor are separate or alternative embodiments mutually exclusive of other embodiments. Further, various features are described which may be exhibited by some embodiments and not by others. Similarly, various requirements are described which may be requirements for some embodiments but not other embodiments.

[0033] The terminology used herein is for the purpose of describing particular embodiments only and is not intended to be limiting of the disclosure. As used herein, the singular forms "a", "an" and "the" are intended to include the plural forms as well, "or" includes "and/or," and reference to a numerical value includes at least that value, unless the context clearly indicates otherwise. Moreover, the use of the terms

first, second, etc. do not denote any order or importance, but rather the terms first, second, etc. are used to distinguish one element from another.

[0034] Within the descriptions of the different views of the figures, the use of the same reference numerals and/or symbols in different drawings indicates identical, similar, or close related items, and similar or closely related elements can be provided similar names, reference numerals, and reference alpha-numerals throughout the figures. If a reference numeral is once used to refer to a plurality of like elements, unless required otherwise by context, the reference numeral may refer to any, a subset of, or all of, the like elements in the figures bearing that reference numeral. Thus, for example, if reference numeral “20” is once referred to a fastening means or device or any element of the fastening means or device, reference numeral “20” may then also refer to any, a subset of, or all of, the elements of the fastening means or device, or the fastening means or device in its entirety, and reference alpha-numeral “20A” may then refer to one implementation or one portion of the fastening means or device, or any, a subset of, or all of the elements of that implementation or that portion. The specific identifiers/names, reference numerals and reference alpha-numerals assigned to the elements are provided solely to aid in the description and are not meant to imply any limitations (structural or functional or otherwise) on the described embodiments.

[0035] In the description, relative terms such as “left,” “right,” “vertical,” “horizontal,” “upper,” “lower,” “top” and “bottom” as well as any derivatives thereof (e.g., “top portion,” “bottom plate,” etc.) should be construed to refer to the logical orientation as then described or as shown in the drawing figure under discussion. These relative terms are for convenience of description and are not intended to convey any limitation with regard to a particular orientation.

[0036] As used herein, the term “fastening means” refers to any suitable known or future fastening mechanism, or any combination of suitable known or future fastening mechanisms (including but are not limited to fastening screws, fastening rivets, fastening bolts, mounting brackets, fastening holes, fastening pegs, fastening hooks, flanges provided for fastening purposes, pressure fitting mechanisms, and so on). As used herein, terms such as “fastening,” “locking,” “securing,” “fastened,” “locked,” “secured”, and so on, may be used interchangeably to refer to securely joining one component to another component, or one component being securely joined to another component.

[0037] Referring now to the detailed description of the disclosed sports ball collector and dispenser apparatus, the disclosed apparatus 10 may generally comprise a receptacle-collector part 100, a multi-purpose tray part 200, and a bracket-handle part 300. With reference now to the figures, and beginning with FIGS. 2A-E, 3, 4A-B and 5A-B, there is illustrated one example of the disclosed apparatus.

[0038] Referring to FIGS. 2A-E, FIGS. 2A-E are a front top view, side top view, front bottom view, back top view, and back bottom view of one exemplary embodiment of the disclosed sports ball collector and dispenser apparatus 10, respectively. Referring to FIG. 2A, which illustrates the exemplary embodiment of the disclosed apparatus 10 in its free-standing mode, the receptacle-collector part 100 look like a “bucket” with the “bucket” frame stands upside down. Receptacle-collector part 100 is generally configured to collect one or more sports balls scattered on, e.g., a floor or a field with an elastic-members-based ball-collector device well

known in the art (which has been discussed in connection with FIGS. 1C, 1D and 1E). Receptacle-collector part 100 generally comprises a receptacle frame 101, a ball-collector device 110, and a controlled-dispenser device 120.

[0039] Receptacle frame 101 is generally configured to form a containment space 105 where collected sports balls (e.g., collected using ball-collector device 110) are stored or otherwise contained. Bottom portion 101 is configured to be integrally joined to ball-collector device 110. Thus, receptacle frame 101 generally comprises a bottom portion 102 and a top portion 103 and an enclosure wall there-between. As illustrated, in this exemplary embodiment, receptacle frame 101 is an upside-down “bucket-like” circular frame, with bottom portion 102 having a bigger diameter than top portion 103 such that the bottom portion 102 tapers towards top portion 103. In one implementation, as illustrated, bottom portion 102 is fastened to an above-discussed elastic-members-based ball-collector device 110 with fastening means 103. In one implementation, top portion 102 and controlled-dispenser device 120 are part of one-cast mold pre-cast together. In another implementation, top portion 102 may be fastened to controlled-dispenser device 120 with one or more known fastening means. A skilled artisan readily appreciate that receptacle frame 101 can be of any suitable shape for its horizontal cross sections, and does not have to be of a circular shape.

[0040] Ball-collector device 110—which, when fastened to bottom portion 102, is at ground level (floor level)—is configured to capture one or multiple sports balls (scattered on a ground or floor) when being pushed downward there-against and retain the captured sports balls there-above. Such a ball-collector device is well known in the art. Typically, such a ball-collector device comprises spaced-apart elastic members each biased to its respective original position with adjacent elastic members spaced slightly smaller than the diameter of a sports ball of a targeted type (such as a table-tennis ball). As such, when a downward force is exerted on ball-collector device 110 while ball-collector device 110 is over one or multiple sports balls, elastic members expand to make respective spaces there-between larger than the diameter of the sports balls (against which ball-collector device 110 are pushed), thus allowing the sports balls to be retained above the elastic members of ball-collector device 110.

[0041] In this exemplary embodiment, referring to FIGS. 2C, 2E, 3 and 5B, ball-collector device 110 comprises ring member 111 and parallel elastic members 112 (e.g., elastic strings 112), with each elastic member 112 fastened to ring member 111 through each of both ends of the respective elastic member being fastened to a corresponding fastening hole 113 disposed on ring member 111. A skilled artisan readily appreciates that there may be many different ways of implementing this elastic-members-based ball-collector device 110. For example, Beavin discloses several different prior art devices implementing such ground-level (floor-level) ball-collector devices, including Beavin’s own featured ball-collector device which may collect sports balls of even different sizes. Each of these prior art ball-collector devices 110 disclosed in Beavin may be used and adapted to implement ball-collector device 110 of the disclosed apparatus 10. Thus, ball-collector device 110 does not have to be of a circular shape. It can be, e.g., a square shape without departing from the spirit and scope of the present disclosure.

[0042] Controlled-dispenser device 120 is configured on one hand to provide an opening for retained sports balls

(retained inside receptacle chamber 105 through an aforementioned collecting operation) to exit receptacle chamber 105. Controlled-dispenser device 120 is configured on another hand to cause the exiting of retained sports balls to be conducted in a controlled (defined) manner so that retained sports balls are prevented from exiting receptacle chamber 105 in an unordered manner (as is the case for the Tucker's seating device). In this embodiment, controlled-dispenser device 120 comprises opening 122 and blocking member 121, with blocking member 121 blocking any potential flow of retained sports balls and opening 122 providing an exit for any potential flow of retained sports balls to exit receptacle chamber 105.

[0043] Referring to FIGS. 2A, 2B, 2C, 3, 4A-B and 5A, multi-purpose tray part 200 is on one hand configured to be fastened to the top portion 103 of receptacle frame 101 in such a manner that the convex-shaped interior surface 214 is in communication with receptacle chamber 105 of receptacle-collector part 100) through a channel formed by opening 122 of controlled-dispenser device 120. With this communication channel, when the disclosed apparatus 100 is positioned or repositioned to a "dispensing mode" by being laid down on a flat surface (referring to FIG. 7A, 7B and 7C), at least of a sub set of sports balls retained in receptacle chamber 105 naturally flows from receptacle chamber 105 to an open-ended chamber 202 defined by interior surface 201 as well as its two raised rims along a flow path 215 defined by the flat portion 215 of interior surface 214.

[0044] Multi-purpose tray part 200 may comprise an elongated tray-shaped body 201. That is, elongated body 201 extends between a generally proximal end 218 (having a convex-shaped interior contour) and a generally distal end 219 (having a convex-shaped interior contour). Elongated body 201 comprises an elongated flat portion 215, two elongated raised rims (edges) 211 (relative to elongated flat portion 215 when elongated flat portion 215 is laid down on a flat surface), and elongated wall portion erected (formed) between elongated flat portion 215 and the two elongated raised rims 211. Elongated flat portion 215, both elongated raised rims (edges) 211, and elongated wall portion form an elongated open-ended chamber 202. A portion of the interior contour of proximal end 218 of elongated body 201 may match or substantially match a portion of the exterior contour of top portion 103, such that proximal end 218 of elongated body 201 is fastened to top portion 103 of receptacle frame 101 along their respective matching portions of contours through known fastening means 20. In particular, opening 122 of controlled-dispenser device 120 (which is integrally joined to top portion 103) is so configured that after proximal 218 is fastened to top portion 103 of receptacle frame 101, at least a portion of opening 122 opens to, and therefore is in communication with, the elongated open-ended chamber 202 of multi-purpose tray part 200.

[0045] Referring to FIGS. 2A, 2B, 2C, 2D, 3, 4A-B and 5A, bracket-handle part 300 is, in one aspect, configured to securely attach a handle 301 to multi-purpose tray part 200 such that the handle 301 is in a substantially and directly elevated position with respect to receptacle-collector part 100, particularly ball-collector device 110, when the disclosed apparatus is oriented in its upright "collecting mode" position (as, e.g., illustrated in FIG. 2A). Bracket-handle part 300 is, in another aspect, configured to provide a limited ball-stopping function (through a limited stopper) aimed to stop the defined flow of sports balls (towards distal end 219 of

the multi-purpose tray part 200 along the defined flow path 215) only when the disclosed apparatus 10 is oriented in or near its horizontal "dispensing mode" position but continue the defined flow of sports balls even beyond past the stopper when the disclosed apparatus 10 is oriented in its tilted "emptying-mode" position.

[0046] Bracket-handle part 300 may comprise handle 301 and a bracket 302 having two opposing ends and a convex-shaped contour of interior surface between the two opposing ends. A portion of the exterior contour of bracket 302 may match or substantially match a corresponding portion of the interior contour of distal end 219 (or a cross section along elongated body 201 substantially parallel to the plane defined by distal end 219), such that bracket 302 may be laterally fastened to distal end 219 (or a horizontal cross section along elongated body 201) with respect to their respective matching contours using known fastening means 22. Handle 301 is laterally disposed and fastened between the two opposing ends of bracket 302 using known fastening means 303. Referring to FIG. 4B, handle 301 is substantially and directly elevated with respect to ball-collector device 110 such that the vertical plane which handle 301 lies in is between the two opposing vertical planes A and B respectively tangent to two opposing points A and B defining a diameter of the circular contour of bottom portion 102 of receptacle frame 101. A skilled artisan readily appreciates that bracket-handle part 300 can be configured in many alternative manners so long as handle 301 is, e.g., within vertical planes A and B. Thus, the bracket-handle part 300 can be so configured that handle 301 is positioned outside chamber 202 (as is the case illustrated in this exemplary embodiment) or alternately inside chamber 202. In another aspect, bracket 302 serves as the aforementioned limited stopper 302 as it is fastened to the interior surface 214 of multi-purpose tray 200.

[0047] Referring to FIGS. 6A-C, when the disclosed apparatus 10 is oriented in its upright direction and stands on the floor when used in its "free-standing mode" or "collecting mode"), handle 301 is of such height that a normal adult user can easily use his/her hands to access, grab and maneuver handle 301 for ball-collecting without any need to bend down his/her back or bend over, thereby avoiding any stress or discomfort associated with bending. Thus, if the user wants to pick up the disclosed apparatus 10, the user can just simply grab handle 301 of an optimal height (to the floor) from the floor and carry the disclosed apparatus 100 using handle 301. If the user wants to collect scattered balls, the user can simply maneuver handle 301 to exert downward force on ball-collector 110 with ease, without any motion of bending down or bending over.

[0048] Referring to FIG. 9B, in one embodiment, the height of handle 301 relative to the floor, when used in its "free-standing mode" or "collecting mode", can be adjusted with known adjusting mechanisms through adjusting or collapsing the length of elongated body 201. In another embodiment, the height of handle 301 may be adjusted by adjusting the fastening position of bracket 302 along the length of elongated body 201 (such as providing adjustment holes along the length of elongated body 201). Thus, the height of handle 301 may be adjusted in accordance with a user's height or the user's hands' natural height relative to the floor (when the user's hands are in a natural dropping down position).

[0049] Referring to FIGS. 7A-C, which collectively illustrate the disclosed apparatus 10 being oriented in its lateral position by being placed along a flat surface (such as ping-

pong table) when used in its “dispensing mode”. Due to physical principles, at least a subset of adequately packed balls retained in the receptacle chamber 105 naturally (automatically) flow into to chamber 202 of multi-purpose tray part 200 through opening 122 along a path 215 defined by flat portion 215 of interior surface 214, and are naturally lined along path 215 until the most distal rolling ball is effectively stopped by stopper 302. In the “dispensing mode”, referring to FIGS. 7B and 7C, the disclosed apparatus 10 may serve as an effective serve practice buddy as the open-ended nature of elongated chamber 202 allows the user to reach with ease inside of chamber 202 along the length of chamber 202 for a ball lining along defined path 215.

[0050] Referring to FIG. 8, which illustrates the disclosed apparatus 10 being oriented in its over-tilted position when used in its “emptying mode”, limited stopper 302 can no longer stop the flowing (rolling) of balls along the defined path 215 as a result of increasing gravity of rolling balls exerted on stopper 302 when the disclosed apparatus 10 is over-tilted, gravity which is large enough to enable rolling balls to overcome and flow (roll) past stopper 302, and drop to the beneath container. Due to that balls are rolling along the defined path 215 (as a result of the convex-shape of interior surface 214 and the two raised rims 211), balls will not roll or drop in an unorderly manner like the “emptying” situation in connection with Beavin’s ball-collector and dispenser apparatus shown in FIG. 1D and the net-scooper apparatus shown in FIG. 1B. A skilled artisan readily appreciates that interior surface 214 can be a convex shape different from the exemplary curved shape illustrated in FIGS. 2A-E, 3, 4A-B, 7A-C and 8. And flat portion 215 may be much wider than flat portion 215 (shown as an exemplary narrow line) illustrated in these figures. For elongated interior surface 214, any generally convex shape of its cross section would work so long as the two elongated raised rims 211, flat portion 215 and elongated wall portion erected (formed) between elongated flat portion 215 and the two elongated raised rims 211, collectively force rolling balls to roll along flat portion 215 without the possibility of balls rolling over either of the two elongated raised rims 211.

[0051] Referring to FIGS. 9A-C, the disclosed apparatus 10 may also be oriented in a reverse-upright direction when used in an alternative mode that facilitate a user to reach inside of the receptacle chamber 105 for balls. In this alternative mode, the apparatus 10 stands on the handle-bracket 300 as support (with handle-bracket 300 is disposed flush with distal end 2019). The multi-purpose tray part 200 is then used as the leg to support receptacle chamber 105, whose bottom portion 103 (which is now at the top) is now of a height close to the natural

hanging position of user’s hands. This enables the user to easily reach inside of chamber 105 for balls stored therein. In the mode, as illustrated, ball collector device 100 is lockingly removable or liftable (not shown) from bottom portion 103 (so that ball-collector device 100 may be removed or lifted to allow access to chamber 105), whereas hinged cover 105 can be switched to lockingly cover opening 122 (so that the retained balls will not drop through opening 122).

[0052] Referring to FIG. 10, a bending mechanism may be provided to enable bending of elongated body 201 so that the apparatus 10 may be used to collect balls scattered under, e.g., a ping-pong table.

[0053] The disclosed apparatus 10 may be manufactured through a one cast mold. With its limited number of elements, that its components are not subject to heavy weight (which causes excess wear and tear), and the use of lightweight and durable materials to construct it, the disclose apparatus 10 should be of lightweight and very durable.

[0054] As such, the present disclosure provides a lightweight and durable ball collector and dispenser apparatus which overcomes the above-discussed undesirable issues in the existing ball-collector apparatuses, The disclosed apparatus is structured and configured to achieve, among many other advantages, a realizing of the pick-and-use type of ease to use, an obviating of any need for bending down when it comes to ball-collecting, and a rendering of the dispensing process easy and defined (controlled) and the emptying process easy and controlled (defined).

[0055] While the disclosure has been described with reference to exemplary embodiments, it will be understood by those skilled in the art, and it is clearly demonstrated through the second embodiment, that various changes may be made and equivalents may be substituted for elements thereof without departing from the scope of the disclosure. In addition, many modifications may be made to adapt a particular system, device or component thereof to the teachings of the disclosure without departing from the essential scope thereof.

[0056] Therefore, it is intended that the disclosure not be limited to the particular embodiments disclosed for carrying out this disclosure, but that the disclosure will include all embodiments falling within the scope of the appended claims.

What is claimed is:

1. A sports ball collector and dispenser apparatus, comprising:
 - a receptacle-collector part;
 - a multi-purpose tray part; and
 - a bracket-handle part.

* * * * *