

(19)
(12)

(KR)
(A)

(51) 。 Int. Cl. ⁷
G02F 1/1337

(11)
(43)

2003 - 0005601
2003 01 23

(21) 10 - 2001 - 0040968
(22) 2001 07 09

(71) . 20

(72) 605 - 212

(74)

:

(54)

, 1

,

,

,

1

2

,

7b

IPS, OCB, , (bend)

1 OCB

2

3

4a 4b 가/ 가

5a 5d

6

7a 7b 가/ 가

*

100, 101 : 1, 2 110a :

111 : 111a :

111b : 113 :

114 : 117 :

118 : 119 :

120 : 121 :

122 : 123 :

125 : 130 :

131, 132 : 1, 2 135 :

(LCD ; Liquid Crystal Display Device)

TV,

(TN : Twisted Nematic)

가 90 °

가

, TN
.

TN 가 .

(Multi - Domain Mode) ,
OCB (Optically Compensated Birefringence Mode) ,

가 , 가
(In - Plane Switching Mode) , 가
de) (VA: Vertical Alignment Mo

, 가 .

OCB

(reset) 가가

가 가 .

OCB

1 OCB

TN
(1,2)

OCB

1

(4)

(3)

(3)

(1,2) 가
0.

10 20.

가

OCB

가

90.

(reset) .

, 가 (4) 가

, 1 2V

가

5 7V

가 .

, OCB

가 ,

가

가

(bend)

가 .

가

OCB

OCB (bi - axial film) (wide view film) 가 .

가 .

2 3 4a
4b 가/ 가 .

1, 2 , R,G,B
1 , 2 (10) (11) (10)
(12) (10) (11) (13) ,
(14) , (14) , (15) ,
14) 1 (10) () .
()
(12) (13) (10) (14)
(11) .
(13) (14)
ITO(Indium Tin Oxide) .
(13) (14)
(short) .
가 (19) , (11) (11a) (10a) , (11b) .
(13) 5V (14) 0V 3
가 .
(13) (14) .
(35)
4a , (35)
4b , .
, 1, 2 1, 2 , 1
(nomally black)

가 4b (35)가 4a (black) (35)가 (white)

4a 4b '13' '14'

TN

, OCB 10ms

(reset)

30ms

가

가

가

1

1

2

가

가

5a 5d

6

7a

7b

가/ 가

5a

1

(100)

(110a)

()

()

(113)

(113)

ITO

(110a) (117) (SiNx) (117) (119)

5b (117) (111) (111a,111b)

(111) (119) / (111b) (114)

(114) (113) (114) ITO

(113)

5c (111) BCB

(118) (120) (120)

(120) (polyvinylcinnamate) (polyazobenzene)

(125) (113) (120) (UV;Ultra violet)

ift) (113) (114) (125) (sh

2 (UV)

(113) (114)

(114) (125) (shift) 3

(Partially polarized light) (linearly polarized light)

1 2

3 1, 2 가

1, 2, 3

6 (113) (114) OCB

가

2-

(polyimide)

,
 , 5d , 2 (101) (Cr)
 (122) (121) R,G,B (122) (121)
 (122) (122) (123)
 , 1 (100) 2 (101) (130)
 1, 2 (100,101) 1, 2 (131,132)
 , 1, 2 (131,132)

(114) 7a (135)가 7b (113)
 (135)가 , 가 가 가
 , 가 .

가 2- 가 .
 , 2- OCB .
 , OCB ,
 가

(57)
 1.
 1 ;
 ;
 ;
 ;
 ;
 ;
 1 2

2.

1 , ,

1 1 ,

2 2 ,

3 3

.

3.

2 , 1 , 2

1 , 3

.

4.

2 , (photo mask)

.

5.

2 , .

6.

2 , ,

.

7.

1 ;

;

;

;

가 ;

1 2 ;

1, 2 1, 2

.

8.

7 , 1, 2

.

9.

1 , 1 2

.

10.

7 , ,

1 ,

1 2 ,

3

.

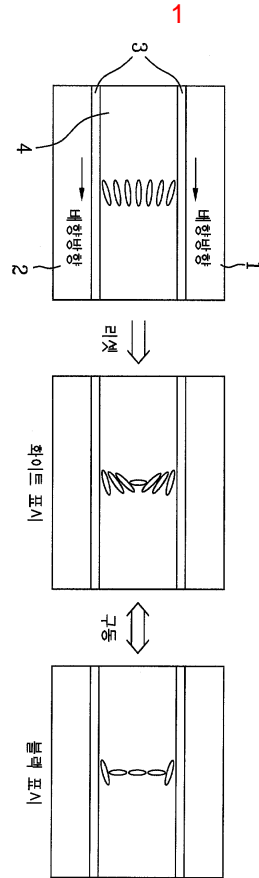

2

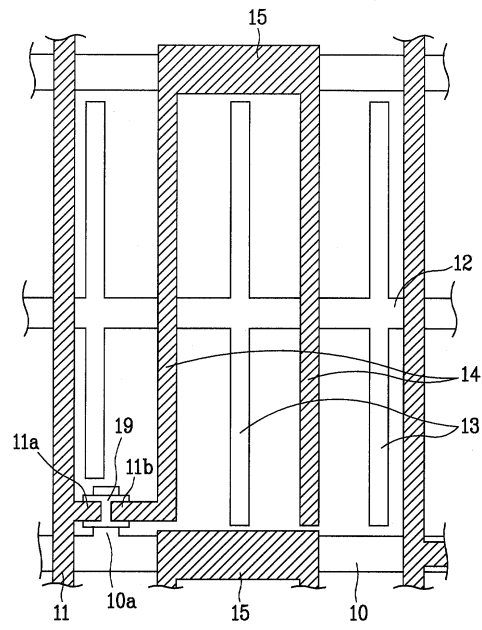

3

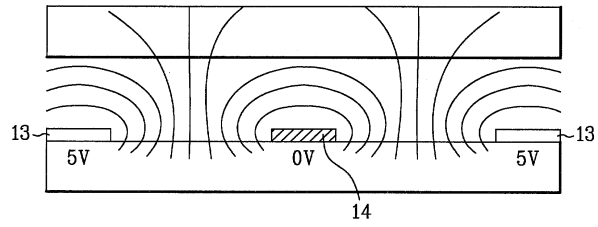

4a

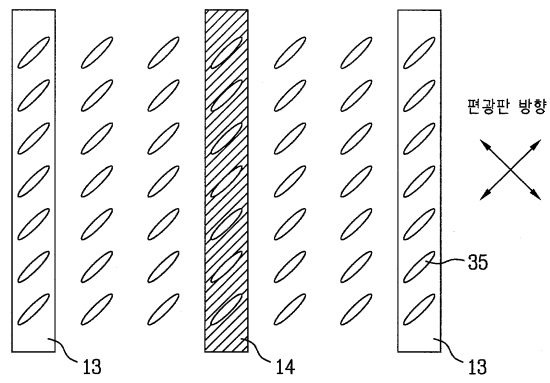

4b

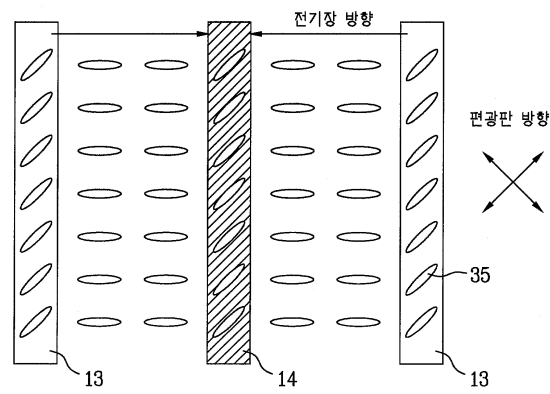

5a

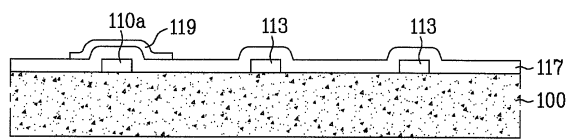

5b

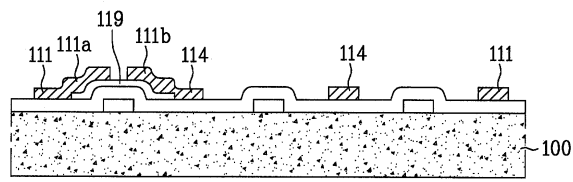

5c

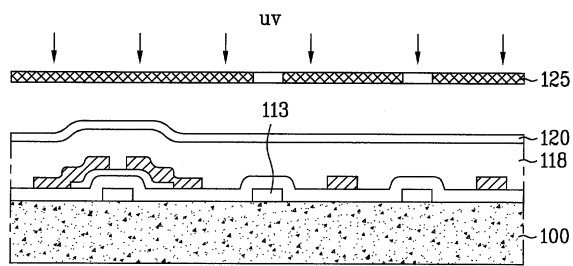

5d

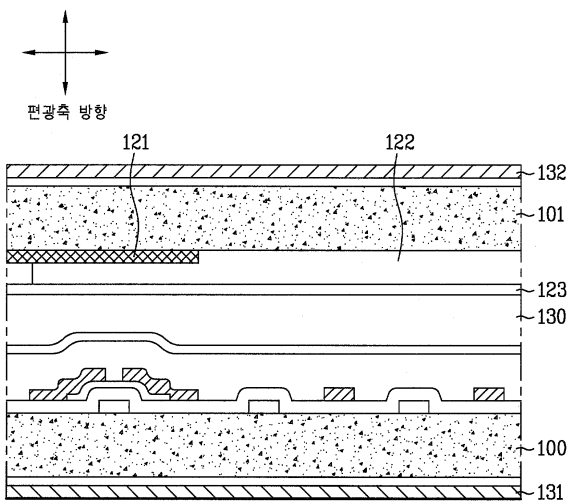

6

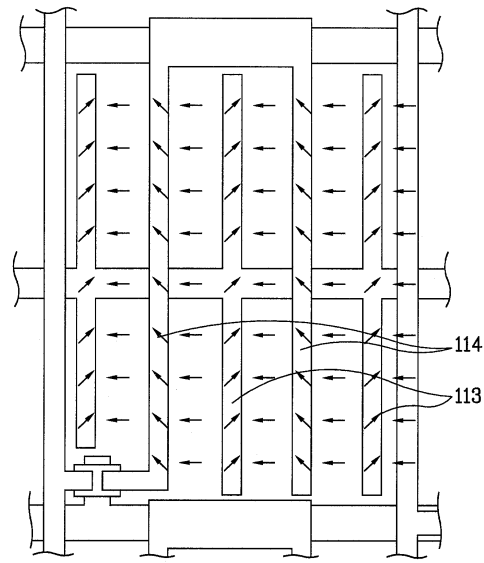

7a

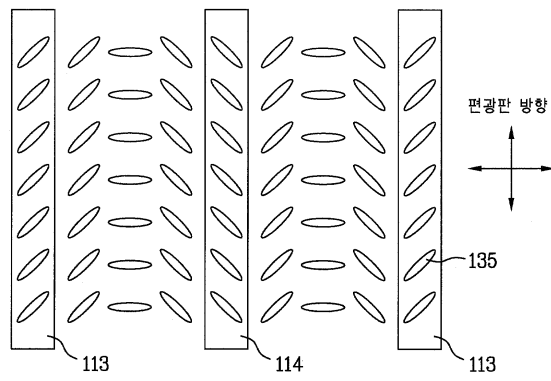

7b

