

(12) **United States Patent**  
**Alderucci et al.**

(10) **Patent No.:** **US 10,751,607 B2**  
(45) **Date of Patent:** **\*Aug. 25, 2020**

(54) **SYSTEMS AND METHODS FOR PROVIDING ACCESS TO LOCATIONS AND SERVICES**

(58) **Field of Classification Search**  
CPC .... G07F 17/32; G07F 17/3227; G07F 17/323; G07F 17/3239; G06Q 30/02;  
(Continued)

(71) Applicant: **CFPH, LLC**, New York, NY (US)

(72) Inventors: **Dean P. Alderucci**, Westport, CT (US); **Joseph M. Asher**, Las Vegas, NV (US); **Robert F. Bahrapour**, New York, NY (US); **Kevin Burman**, Sydney (AU); **James J. Coffey**, Norwalk, CT (US); **Ronald Rushin**, Las Vegas, NV (US)

(56) **References Cited**  
U.S. PATENT DOCUMENTS  
3,580,581 A 5/1971 Raven  
3,838,259 A 9/1974 Kortenhaus  
(Continued)

(73) Assignee: **CFPH, LLC**, New York, NY (US)

FOREIGN PATENT DOCUMENTS

(\* ) Notice: Subject to any disclaimer, the term of this patent is extended or adjusted under 35 U.S.C. 154(b) by 0 days.

CN 1346549 4/2002  
DE 31 29 550 A1 4/1982  
(Continued)

This patent is subject to a terminal disclaimer.

OTHER PUBLICATIONS

(21) Appl. No.: **16/387,823**

Solutions for Restaurants, Hotels & Resorts and Clubs—Guest bridge, Inc. (online). Guestbridge, Inc. Feb. 6, 2007 [retrieved on Aug. 21, 2008]. Retrieved from the Internet: <URL: http://web.archive.org/web/20070206134139/www.guestbridge.com/solutions.html, entire document especially p. 1.  
(Continued)

(22) Filed: **Apr. 18, 2019**

(65) **Prior Publication Data**  
US 2019/0247746 A1 Aug. 15, 2019

*Primary Examiner* — Thien M Le

**Related U.S. Application Data**

(63) Continuation of application No. 14/252,407, filed on Apr. 14, 2014, now Pat. No. 10,286,300, which is a  
(Continued)

(57) **ABSTRACT**  
Systems and methods for controlling access to wireless gaming devices and networks are provided. For example, access is controlled through one or more levels of security checks, such as a hard security check instead of or in addition to a soft security check. In a hard security check, the user employs an apparatus such as a card or other physical token that can be used to access the wireless gaming device. Such an apparatus may communicate information that identifies the user to the device or may simply be used to produce a signal without which the device is locked to users.

(51) **Int. Cl.**  
**G06K 5/00** (2006.01)  
**A63F 13/212** (2014.01)  
(Continued)

**7 Claims, 5 Drawing Sheets**

(52) **U.S. Cl.**  
CPC ..... **A63F 13/212** (2014.09); **A63F 13/12** (2013.01); **A63F 13/50** (2014.09); **G07F 17/32** (2013.01);  
(Continued)

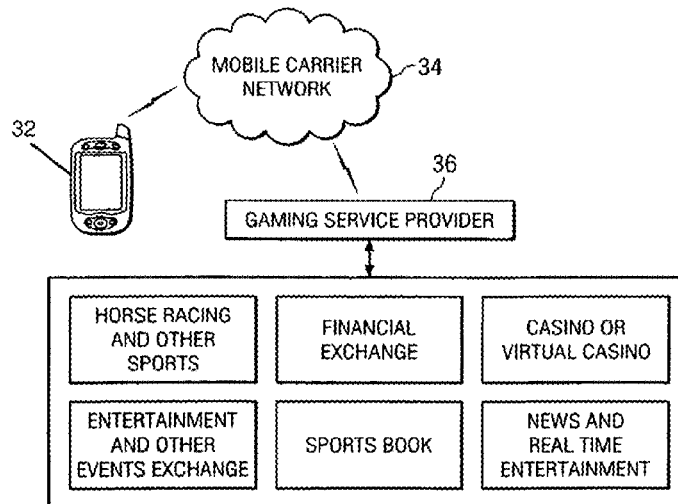

**Related U.S. Application Data**

continuation of application No. 12/324,269, filed on Nov. 26, 2008, now Pat. No. 8,695,876, which is a continuation of application No. 11/418,939, filed on May 5, 2006, now Pat. No. 7,549,576.

(51) **Int. Cl.**

**G07F 17/32** (2006.01)  
**H04L 29/06** (2006.01)  
**A63F 13/30** (2014.01)  
**A63F 13/50** (2014.01)

(52) **U.S. Cl.**

CPC ..... **G07F 17/3223** (2013.01); **H04L 63/105** (2013.01); **H04L 2463/102** (2013.01)

(58) **Field of Classification Search**

CPC .... G06Q 30/0277; G06Q 50/22; G06Q 50/34;  
 G09B 19/00; G09B 5/02; H04L 51/046;  
 H04L 67/20

See application file for complete search history.

(56)

**References Cited**

U.S. PATENT DOCUMENTS

3,876,208 A 4/1975 Wachtler et al.  
 3,929,338 A 12/1975 Busch  
 4,101,129 A 7/1978 Cox  
 4,120,294 A 10/1978 Wolfe  
 4,157,829 A 6/1979 Goldman et al.  
 4,206,920 A 6/1980 Weatherford et al.  
 4,216,965 A 8/1980 Morrison et al.  
 4,238,127 A 12/1980 Lucero et al.  
 4,240,635 A 12/1980 Brown  
 4,266,214 A 5/1981 Peters, Jr.  
 4,335,809 A 6/1982 Wain  
 4,448,419 A 5/1984 Telnaes  
 4,467,424 A 8/1984 Hedges et al.  
 4,492,379 A 1/1985 Okada  
 4,527,798 A 7/1985 Siekierski et al.  
 4,572,509 A 2/1986 Stirick  
 4,573,681 A 3/1986 Okada  
 4,614,342 A 9/1986 Takashima  
 4,624,459 A 11/1986 Kaufman  
 4,636,951 A 1/1987 Harlick  
 4,648,600 A 3/1987 Oliiges  
 4,652,998 A 3/1987 Koza et al.  
 4,692,863 A 9/1987 Moosz  
 4,760,527 A 7/1988 Sidley  
 4,805,907 A 2/1989 Hagiwara  
 4,810,868 A 3/1989 Drexler  
 4,817,951 A 4/1989 Crouch et al.  
 4,838,552 A 6/1989 Hagiwara  
 4,853,884 A 8/1989 Brown et al.  
 4,856,787 A 8/1989 Itkis  
 4,858,932 A 8/1989 Keane  
 4,880,237 A 11/1989 Kishishita  
 4,882,473 A 11/1989 Bergeron et al.  
 4,909,516 A 3/1990 Kolinsky  
 4,926,327 A 5/1990 Sidley  
 4,959,783 A 9/1990 Scott et al.  
 4,964,638 A 10/1990 Ishida  
 5,001,632 A 3/1991 Hall-Tipping  
 5,007,087 A 4/1991 Bernstein et al.  
 5,024,441 A 6/1991 Rosseau  
 5,048,833 A 9/1991 Lamle  
 5,050,881 A 9/1991 Nagao  
 5,055,662 A 10/1991 Hasegawa  
 5,056,141 A 10/1991 Dyke  
 5,074,559 A 12/1991 Okada  
 5,083,785 A 1/1992 Okada  
 5,096,195 A 3/1992 Gimmon  
 5,096,202 A 3/1992 Hesland  
 5,102,134 A 4/1992 Smyth  
 5,151,684 A 9/1992 Johnsen

5,192,076 A 3/1993 Komori  
 5,229,764 A 7/1993 Matchett et al.  
 5,242,163 A 9/1993 Fulton  
 5,251,165 A 10/1993 James, III  
 5,251,898 A 10/1993 Dickenson et al.  
 5,263,716 A 11/1993 Smyth  
 5,265,874 A 11/1993 Dickinson et al.  
 5,280,426 A 1/1994 Edmonds  
 5,280,909 A 1/1994 Tracy  
 5,298,476 A 3/1994 Hotta et al.  
 5,324,035 A 6/1994 Morris et al.  
 5,326,104 A 7/1994 Pease et al.  
 5,344,199 A 9/1994 Carstens et al.  
 5,351,970 A 10/1994 Fioretti  
 5,359,183 A 10/1994 Skodlar  
 5,370,306 A 12/1994 Schulze et al.  
 5,380,007 A 1/1995 Travis et al.  
 5,380,008 A 1/1995 Mathis et al.  
 5,393,061 A 2/1995 Manship et al.  
 5,398,932 A 3/1995 Eberhardt et al.  
 5,415,416 A 5/1995 Scagnelli et al.  
 5,421,576 A 6/1995 Yamazaki et al.  
 5,429,361 A 7/1995 Raven et al.  
 5,471,044 A 11/1995 Hotta et al.  
 5,476,259 A 12/1995 Weingardt  
 5,505,449 A 4/1996 Eberhardt et al.  
 5,507,485 A 4/1996 Fisher  
 5,511,784 A 4/1996 Furry et al.  
 5,524,888 A 6/1996 Heidel  
 5,534,685 A 7/1996 Takemoto et al.  
 5,551,692 A 9/1996 Pettit et al.  
 5,569,083 A 10/1996 Fioretti  
 5,569,084 A 10/1996 Nicastro et al.  
 5,580,309 A 12/1996 Piechowiak et al.  
 5,586,937 A 12/1996 Menashe  
 5,588,913 A 12/1996 Hecht  
 5,594,233 A 1/1997 Kenneth  
 5,599,231 A 2/1997 Hibino et al.  
 5,613,912 A 3/1997 Slater  
 5,618,045 A 4/1997 Kagan et al.  
 5,618,232 A 4/1997 Martin  
 5,645,277 A 7/1997 Cheng  
 5,653,634 A 8/1997 Hodges  
 5,654,746 A 8/1997 McMulan, Jr. et al.  
 5,655,961 A 8/1997 Acres et al.  
 5,675,828 A 10/1997 Stoel et al.  
 5,697,844 A 12/1997 Von Kohorn  
 5,702,302 A 12/1997 Gauselman  
 5,707,286 A 1/1998 Carlson  
 5,738,583 A 4/1998 Comas et al.  
 5,745,102 A 4/1998 Bloch et al.  
 5,762,552 A 6/1998 Vuong et al.  
 5,764,789 A 6/1998 Pare, Jr. et al.  
 5,766,076 A 6/1998 Pease et al.  
 5,768,382 A 6/1998 Schneier et al.  
 5,772,508 A 6/1998 Sugita et al.  
 5,779,549 A 7/1998 Walker  
 5,785,595 A 7/1998 Gauselman  
 5,787,156 A 7/1998 Katz  
 5,806,849 A 9/1998 Rutkowski  
 5,816,918 A 10/1998 Kelly et al.  
 5,816,920 A 10/1998 Hanai  
 5,851,148 A 10/1998 Brune et al.  
 5,833,536 A 11/1998 Davids et al.  
 5,835,722 A 11/1998 Bradshaw et al.  
 5,836,817 A 11/1998 Acres et al.  
 5,857,911 A 1/1999 Fioretti  
 5,871,398 A 2/1999 Schneier et al.  
 5,878,211 A 3/1999 Delagrance  
 5,881,366 A 3/1999 Bodermann et al.  
 5,889,474 A 3/1999 LaDue  
 5,902,983 A 5/1999 Crevelt et al.  
 5,904,619 A 5/1999 Scagnelli et al.  
 5,904,620 A 5/1999 Kujawa  
 5,907,282 A 5/1999 Tuorto et al.  
 5,910,047 A 6/1999 Scagnelli et al.  
 5,920,640 A 7/1999 Salatino et al.  
 5,921,865 A 7/1999 Scagnelli  
 5,931,764 A 8/1999 Freeman et al.

(56)

## References Cited

## U.S. PATENT DOCUMENTS

5,935,005	A	8/1999	Tsuda et al.	6,508,710	B1	1/2003	Paravia et al.
5,951,397	A	9/1999	Dickinson	6,509,217	B1	1/2003	Reddy
5,954,583	A	9/1999	Green	6,520,853	B2	2/2003	Suzuki
5,955,961	A	9/1999	Wallerstein	6,524,189	B1	2/2003	Rautila
5,959,596	A	9/1999	McCarten et al.	6,526,158	B1	2/2003	Goldberg
5,970,143	A	10/1999	Schneier et al.	6,527,641	B1	3/2003	Sinclair et al.
5,977,957	A	11/1999	Miller et al.	6,542,750	B2	4/2003	Hendrey et al.
5,987,611	A	11/1999	Freund	6,554,705	B1	4/2003	Cumbers
5,991,431	A	11/1999	Borza et al.	6,554,707	B1	4/2003	Sinclair
5,995,630	A	11/1999	Borza et al.	6,556,819	B2	4/2003	Irvin
5,999,808	A	12/1999	LaDue	6,575,834	B1	6/2003	Lindo
6,001,015	A	12/1999	Nishiumi et al.	6,577,733	B1	6/2003	Charrin
6,001,016	A	12/1999	Walker et al.	6,582,302	B2	6/2003	Romero
6,003,013	A	12/1999	Boushy et al.	6,585,597	B2	7/2003	Finn
6,011,973	A	1/2000	Valentine et al.	6,604,980	B1	8/2003	Jurmain
6,012,636	A	1/2000	Smith	6,612,928	B1	9/2003	Bradford et al.
6,012,982	A	1/2000	Piechowiak et al.	6,614,350	B1	9/2003	Lunsford
6,019,284	A	2/2000	Freeman et al.	6,618,706	B1	9/2003	Rive et al.
6,022,274	A	2/2000	Takeda et al.	6,622,157	B1	9/2003	Heddaya et al.
6,027,115	A	2/2000	Griswold et al.	6,628,939	B2	9/2003	Paulsen
6,044,062	A	3/2000	Brownrigg et al.	6,631,849	B2	10/2003	Blossom
6,048,269	A	4/2000	Burns et al.	6,634,942	B2	10/2003	Walker
6,050,622	A	4/2000	Gustafson	6,645,077	B2	11/2003	Rowe
6,065,056	A	5/2000	Bradshaw et al.	6,652,378	B2	11/2003	Cannon et al.
6,080,061	A	6/2000	Watanabe et al.	6,676,522	B2	1/2004	Rowe et al.
6,098,985	A	8/2000	Moody	6,680,675	B1	1/2004	Suzuki
6,099,408	A	8/2000	Schneier et al.	6,682,421	B1	1/2004	Rowe et al.
6,100,804	A	8/2000	Brady et al.	6,691,032	B1	2/2004	Irish et al.
6,104,295	A	8/2000	Gaisser et al.	6,709,333	B1	3/2004	Bradford et al.
6,104,815	A	8/2000	Alcorn	6,719,631	B1	4/2004	Tulley et al.
6,117,011	A	9/2000	Lvov	6,721,542	B1	4/2004	Anttila et al.
6,135,884	A	10/2000	Hedrick et al.	6,729,956	B2	5/2004	Wolf et al.
6,139,431	A	10/2000	Walker et al.	6,743,098	B2	6/2004	Urie et al.
6,146,270	A	11/2000	Huard et al.	6,745,011	B1	6/2004	Hendrickson
6,148,094	A	11/2000	Kinsella	6,749,505	B1	6/2004	Kunzle
6,177,905	B1	1/2001	Welch	6,754,210	B1	6/2004	Ofek
6,178,255	B1	1/2001	Scott et al.	6,755,742	B1	6/2004	Hartman
6,178,510	B1	1/2001	O'Connoe et al.	6,756,882	B2	6/2004	Benes
6,183,366	B1	2/2001	Goldberg et al.	6,761,638	B1	7/2004	Narita
6,193,153	B1	2/2001	Lambert	6,773,350	B2	8/2004	Yoshimi et al.
6,196,920	B1	3/2001	Spaur et al.	6,778,820	B2	8/2004	Tendler
6,210,274	B1	4/2001	Carlson	6,793,580	B2	9/2004	Sinclair
6,212,392	B1	4/2001	Fitch et al.	6,800,029	B2	10/2004	Rowe et al.
6,219,439	B1	4/2001	Burger	6,800,031	B2	10/2004	Di Cesare
6,233,448	B1	5/2001	Alperovich et al.	6,801,934	B1	10/2004	Eranko
6,248,017	B1	6/2001	Roach	6,802,772	B1	10/2004	Kunzle
6,251,014	B1	6/2001	Stockdale et al.	6,806,889	B1	10/2004	Malaure
6,251,017	B1	6/2001	Leason et al.	6,812,824	B1	11/2004	Goldinger et al.
6,264,560	B1	7/2001	Goldberg et al.	6,834,195	B2	12/2004	Brandenberg et al.
6,265,973	B1	7/2001	Brammall et al.	6,837,789	B2	1/2005	Garahi et al.
6,272,223	B1	8/2001	Carlson	6,839,560	B1	1/2005	Bahl et al.
6,277,026	B1	8/2001	Archer	6,843,412	B1	1/2005	Sanford
6,277,029	B1	8/2001	Hanley	6,843,725	B2	1/2005	Nelson
6,280,325	B1	8/2001	Fisk	6,846,238	B2	1/2005	Wells et al.
6,287,202	B1	9/2001	Pascal et al.	6,857,959	B1	2/2005	Nguyen
6,290,601	B1	9/2001	Yamazaki et al.	6,863,610	B2	3/2005	Vancracynest
RE37,414	E	10/2001	Harlick	6,868,396	B2	3/2005	Smith et al.
6,309,307	B1	10/2001	Krause et al.	6,884,162	B2	4/2005	Raverdy
6,320,495	B1	11/2001	Sporgis	6,884,166	B2	4/2005	Leen et al.
6,325,285	B1	12/2001	Baratelli	6,887,151	B2	5/2005	Leen et al.
6,325,292	B1	12/2001	Sehr	6,887,159	B2	5/2005	Leen et al.
6,331,148	B1	12/2001	Krause et al.	6,892,218	B2	5/2005	Heddaya et al.
6,359,661	B1	3/2002	Nickum	6,892,938	B2	5/2005	Solomon
6,386,976	B1	5/2002	Yamazaki et al.	6,893,347	B1	5/2005	Zilliacus
6,388,612	B1	5/2002	Neher	6,896,618	B2	5/2005	Benoy et al.
6,409,602	B1	6/2002	Wiltshire et al.	6,898,299	B1	5/2005	Brooks
6,424,029	B1	7/2002	Giesler	6,899,628	B2	5/2005	Leen et al.
6,425,828	B2	7/2002	Walker et al.	6,904,520	B1	6/2005	Rosset
6,428,413	B1	8/2002	Carlson	6,908,387	B2	6/2005	Hedrick et al.
6,441,752	B1	8/2002	Fomukong	6,908,391	B2	6/2005	Gatto et al.
6,454,648	B1	9/2002	Kelly	6,923,724	B2	8/2005	Williams
RE37,885	E	10/2002	Acres et al.	6,935,952	B2	8/2005	Walker et al.
6,468,155	B1	10/2002	Zucker	6,935,958	B2	8/2005	Nelson
6,507,279	B2	1/2003	Loof	6,942,574	B1	9/2005	Lemay et al.
6,508,709	B1	1/2003	Karmarkar	6,945,870	B2	9/2005	Gatto et al.
				RE38,812	E	10/2005	Acres et al.
				6,966,832	B2	11/2005	Leen et al.
				6,979,264	B2	12/2005	Chatigny et al.
				6,979,267	B2	12/2005	Leen et al.

(56)	<b>References Cited</b>		7,744,002 B2	6/2010	Jones et al.	
	U.S. PATENT DOCUMENTS		7,802,724 B1*	9/2010	Nohr .....	G07C 9/00111 235/384
			7,819,749 B1	10/2010	Fish et al.	
6,984,175 B2	1/2006	Ngyuyen et al.	7,828,652 B2	11/2010	Nguyen et al.	
6,986,055 B2	1/2006	Carlson	7,828,654 B2	11/2010	Carter, Sr.	
6,997,810 B2	2/2006	Cole	7,828,661 B1	11/2010	Fish et al.	
7,021,623 B2	4/2006	Leen et al.	7,867,083 B2	1/2011	Wells et al.	
7,022,017 B1	4/2006	Halbritter et al.	7,946,917 B2	5/2011	Kaminkow et al.	
7,029,394 B2	4/2006	Leen et al.	7,967,682 B2	6/2011	Huizinga	
7,033,276 B2	4/2006	Walker et al.	8,016,667 B2	9/2011	Benbrahim	
7,034,683 B2	4/2006	Ghazarian	8,047,914 B2	11/2011	Morrow	
7,035,653 B2	4/2006	Simon et al.	8,123,616 B2	2/2012	Wells et al.	
7,040,987 B2	5/2006	Walker et al.	8,142,283 B2	3/2012	Lutnick	
7,042,360 B2	5/2006	Light et al.	8,162,756 B2	4/2012	Amaitis et al.	
7,042,391 B2	5/2006	Meunier et al.	8,221,225 B2	7/2012	Laut	
7,043,641 B1	5/2006	Martinek et al.	8,267,789 B2	9/2012	Nelson	
7,047,197 B1	5/2006	Bennett	8,285,484 B1	10/2012	Lau	
7,097,562 B2	8/2006	Gagner	8,287,380 B2	10/2012	Nguyen	
7,081,815 B2	9/2006	Runyon et al.	8,298,078 B2	10/2012	Sutton et al.	
7,102,507 B1	9/2006	Lauren	8,393,948 B2	3/2013	Allen	
7,102,509 B1	9/2006	Anders et al.	8,397,985 B2	3/2013	Alderucci et al.	
7,124,947 B2	10/2006	Storch	8,403,214 B2	3/2013	Alderucci et al.	
7,125,334 B2	10/2006	Yamazaki et al.	8,425,314 B2	4/2013	Benbrahim	
7,128,482 B2	10/2006	Meyerhofer et al.	8,740,065 B2	6/2014	Alderucci et al.	
7,144,011 B2	12/2006	Asher et al.	8,764,566 B2	7/2014	Miltenberger	
7,147,558 B2	12/2006	Giobbi	8,899,477 B2	12/2014	Gelman	
7,158,798 B2	1/2007	Lee et al.	8,939,359 B2	1/2015	Gelman	
7,168,626 B2	1/2007	Lerch et al.	9,280,648 B2	3/2016	Alderucci	
7,185,360 B1	2/2007	Anton et al.	9,306,952 B2	4/2016	Burman et al.	
7,194,273 B2	3/2007	Vaudreuil	9,355,518 B2	5/2016	Amaitis et al.	
7,207,885 B2	4/2007	Longman	9,430,901 B2	8/2016	Amaitis et al.	
7,228,651 B1	6/2007	Saari	9,489,793 B2	11/2016	Williams et al.	
7,229,354 B2	6/2007	McNutt et al.	10,286,300 B2*	5/2019	Alderucci .....	G07F 17/32
7,229,385 B2	6/2007	Freeman et al.	10,460,557 B2*	10/2019	Alderucci .....	G07F 17/3225
7,233,922 B2	6/2007	Asher et al.	10,535,223 B2	1/2020	Gelman	
7,248,852 B2	7/2007	Cabrera et al.	2001/0018663 A1	8/2001	Dusell et al.	
7,270,605 B2	9/2007	Russell et al.	2001/0026240 A1	10/2001	Neher	
7,284,708 B2	10/2007	Martin	2001/0026610 A1	10/2001	Katz et al.	
7,288,025 B1	10/2007	Cumbers	2001/0026632 A1	10/2001	Tamai	
7,288,028 B2	10/2007	Rodriguez et al.	2001/0027130 A1	10/2001	Namba et al.	
7,290,264 B1	10/2007	Powers et al.	2001/0028308 A1	10/2001	De La Huerga	
7,297,062 B2	11/2007	Gatto et al.	2001/0031663 A1	10/2001	Johnson	
7,306,514 B2	12/2007	Amaitis et al.	2001/0034237 A1	10/2001	Garahi	
7,311,605 B2	12/2007	Moser	2001/0034268 A1	10/2001	Thomas et al.	
7,311,606 B2	12/2007	Amaitis et al.	2001/0036858 A1	11/2001	McNutt et al.	
7,316,619 B2	1/2008	Nelson	2001/0049275 A1	12/2001	Piery et al.	
7,341,517 B2	3/2008	Asher et al.	2001/0055991 A1	12/2001	Hightower	
7,357,717 B1	4/2008	Cumbers	2002/0002075 A1	1/2002	Rowe	
7,394,405 B2	7/2008	Godden	2002/0013827 A1	1/2002	Edstrom et al.	
7,413,513 B2	8/2008	Nguyen et al.	2002/0034978 A1	3/2002	Legge et al.	
7,429,215 B2	9/2008	Rozkin	2002/0037767 A1	3/2002	Ebin	
7,431,650 B2	10/2008	Kessman	2002/0049909 A1	4/2002	Jackson et al.	
7,435,179 B1	10/2008	Ford	2002/0052231 A1	5/2002	Fioretti	
7,437,147 B1	10/2008	Luciano, Jr.	2002/0065097 A1	5/2002	Brockenbrough	
7,442,124 B2	10/2008	Asher et al.	2002/0068631 A1	6/2002	Raverdy	
7,450,010 B1	11/2008	Gravelle	2002/0073021 A1	6/2002	Ginsberg et al.	
7,452,273 B2	11/2008	Amaitis et al.	2002/0074725 A1	6/2002	Stern	
7,452,274 B2	11/2008	Amaitis et al.	2002/0087505 A1	7/2002	Smith	
7,458,891 B2	12/2008	Asher et al.	2002/0095586 A1	7/2002	Doyle et al.	
7,458,894 B2	12/2008	Danieli	2002/0111210 A1	8/2002	Luciano	
7,460,863 B2	12/2008	Steelberg et al.	2002/0111213 A1	8/2002	McEntee et al.	
7,470,191 B2	12/2008	Xidos	2002/0119817 A1	8/2002	Behm	
7,479,065 B1	1/2009	McAllister et al.	2002/0123377 A1	9/2002	Shulman	
7,506,172 B2	3/2009	Bhakta	2002/0124182 A1	9/2002	Basco	
7,510,474 B2	3/2009	Carter	2002/0125886 A1	9/2002	Bates et al.	
7,534,169 B2	5/2009	Amaitis et al.	2002/0128057 A1	9/2002	Walker et al.	
7,546,946 B2	6/2009	Hefner et al.	2002/0132663 A1	9/2002	Cumbers	
7,549,576 B2	6/2009	Alderucci et al.	2002/0138461 A1	9/2002	Sinclair	
7,549,756 B2	6/2009	Willis et al.	2002/0142839 A1	10/2002	Wolinsky	
7,562,034 B2	7/2009	Asher et al.	2002/0142844 A1	10/2002	Kerr	
7,566,270 B2	7/2009	Amaitis et al.	2002/0142846 A1	10/2002	Paulsen	
7,577,847 B2	8/2009	Nguyen	2002/0143960 A1	10/2002	Goren	
7,637,810 B2	12/2009	Amaitis et al.	2002/0143991 A1	10/2002	Chow et al.	
7,665,668 B2	2/2010	Phillips	2002/0147047 A1	10/2002	Letovsky	
7,686,687 B2	3/2010	Cannon et al.	2002/0147049 A1	10/2002	Carter, Sr.	
7,689,459 B2	3/2010	Capurso et al.	2002/0147762 A1*	10/2002	Tree .....	G06F 1/163 709/201
7,736,221 B2	6/2010	Black et al.				
7,742,972 B2	6/2010	Lange et al.	2002/0151344 A1	10/2002	Tanskanen	

(56)		References Cited					
		U.S. PATENT DOCUMENTS					
2002/0155884	A1	10/2002	Updike	2003/0224855	A1	12/2003	Cunningham
2002/0157090	A1	10/2002	Anton, Jr.	2003/0228895	A1	12/2003	Edelson
2002/0160834	A1	10/2002	Urie et al.	2003/0228898	A1	12/2003	Rowe
2002/0160838	A1	10/2002	Kim	2003/0228901	A1	12/2003	Walker et al.
2002/0165020	A1	11/2002	Koyama	2003/0228907	A1	12/2003	Gatto et al.
2002/0174336	A1	11/2002	Sakakibara et al.	2003/0228910	A1	12/2003	Jawaharla et al.
2002/0183105	A1	12/2002	Cannon et al.	2003/0236120	A1	12/2003	Reece
2002/0184653	A1	12/2002	Pierce et al.	2004/0002355	A1	1/2004	Spencer
2002/0191017	A1	12/2002	Sinclair	2004/0002383	A1	1/2004	Lundy
2002/0198044	A1	12/2002	Walker	2004/0002386	A1	1/2004	Wolfe et al.
2002/0198051	A1	12/2002	Lobel et al.	2004/0002843	A1	1/2004	Robarts
2003/0003988	A1	1/2003	Walker et al.	2004/0005919	A1	1/2004	Walker
2003/0003997	A1	1/2003	Vuong et al.	2004/0009812	A1	1/2004	Scott et al.
2003/0006931	A1	1/2003	Mages	2004/0014522	A1	1/2004	Walker et al.
2003/0008662	A1	1/2003	Stern et al.	2004/0029635	A1	2/2004	Giobbi
2003/0009603	A1	1/2003	Ruths et al.	2004/0029638	A1	2/2004	Hytchenson
2003/0013438	A1	1/2003	Darby	2004/0034775	A1	2/2004	Desjardins et al.
2003/0013513	A1	1/2003	Rowe	2004/0038734	A1	2/2004	Adams
2003/0014639	A1	1/2003	Jackson et al.	2004/0043763	A1	3/2004	Minear
2003/0017871	A1	1/2003	Urie et al.	2004/0044774	A1	3/2004	Mangalik et al.
2003/0022718	A1	1/2003	Salerno	2004/0048613	A1	3/2004	Sayers
2003/0027631	A1	2/2003	Hedrick et al.	2004/0053692	A1	3/2004	Chatingny et al.
2003/0028567	A1	2/2003	Carlson	2004/0061646	A1	4/2004	Andrews et al.
2003/0031321	A1	2/2003	Mages	2004/0063497	A1	4/2004	Gould
2003/0032407	A1	2/2003	Mages	2004/0066296	A1	4/2004	Atherton
2003/0032434	A1	2/2003	Willner et al.	2004/0067760	A1	4/2004	Menjo et al.
2003/0032474	A1	2/2003	Kaminkow	2004/0068441	A1	4/2004	Werbitt
2003/0036425	A1	2/2003	Kaminkow et al.	2004/0068532	A1	4/2004	Dewing
2003/0036428	A1	2/2003	Aasland	2004/0083394	A1	4/2004	Brebner et al.
2003/0040324	A1	2/2003	Eldering et al.	2004/0092306	A1	5/2004	George et al.
2003/0045269	A1	3/2003	Himmel	2004/0092311	A1	5/2004	Weston
2003/0045353	A1	3/2003	Paulsen et al.	2004/0097283	A1	5/2004	Piper
2003/0045354	A1	3/2003	Globbi	2004/0097287	A1	5/2004	Postrel
2003/0045358	A1	3/2003	Leen et al.	2004/0104274	A1	6/2004	Kotik et al.
2003/0050115	A1	3/2003	Leen et al.	2004/0104845	A1	6/2004	McCarthy
2003/0054878	A1	3/2003	Benoy et al.	2004/0110565	A1	6/2004	Levesque
2003/0060286	A1	3/2003	Walker	2004/0111369	A1	6/2004	Lane et al.
2003/0064712	A1	4/2003	Gaston	2004/0118930	A1	6/2004	Berardi et al.
2003/0064798	A1	4/2003	Grauzer et al.	2004/0127277	A1	7/2004	Walker et al.
2003/0064805	A1	4/2003	Wells	2004/0127289	A1	7/2004	Davis
2003/0064807	A1	4/2003	Walker et al.	2004/0132530	A1	7/2004	Rutanen
2003/0065805	A1	4/2003	Barnes, Jr.	2004/0137983	A1	7/2004	Kerr et al.
2003/0069071	A1	4/2003	Britt et al.	2004/0137987	A1	7/2004	Nguyen et al.
2003/0069940	A1	4/2003	Kavacheri et al.	2004/0142744	A1	7/2004	Atkinson et al.
2003/0078101	A1	4/2003	Schneider et al.	2004/0147323	A1	7/2004	Cliff et al.
2003/0087652	A1	5/2003	Simon et al.	2004/0152511	A1	8/2004	Nicely
2003/0087701	A1	5/2003	Paravia et al.	2004/0162124	A1	8/2004	Barton
2003/0104851	A1	6/2003	Merari	2004/0162144	A1	8/2004	Loose
2003/0104865	A1	6/2003	Itkis et al.	2004/0185881	A1	9/2004	Lee et al.
2003/0109306	A1	6/2003	Karmarkar	2004/0186768	A1	9/2004	Wakim et al.
2003/0109310	A1	6/2003	Heaton et al.	2004/0189470	A1	9/2004	Girvin et al.
2003/0114218	A1	6/2003	McClintic	2004/0192438	A1	9/2004	Wells et al.
2003/0125973	A1	7/2003	Mathews	2004/0192442	A1	9/2004	Wells et al.
2003/0130032	A1	7/2003	Martinek et al.	2004/0193469	A1	9/2004	Amaitis et al.
2003/0139190	A1	7/2003	Steelberg	2004/0193531	A1	9/2004	Amaitis et al.
2003/0140131	A1	7/2003	Chandrashekhar	2004/0198386	A1	10/2004	Dupray
2003/0144047	A1	7/2003	Sprogis	2004/0198396	A1	10/2004	Fransioli
2003/0148809	A1	8/2003	Nelson	2004/0198398	A1	10/2004	Amir et al.
2003/0148812	A1	8/2003	Paulsen et al.	2004/0198403	A1	10/2004	Pedersen et al.
2003/0157976	A1	8/2003	Simon	2004/0198483	A1	10/2004	Amaitis et al.
2003/0162580	A1	8/2003	Cousineau	2004/0209660	A1	10/2004	Carlson
2003/0162593	A1	8/2003	Griswold et al.	2004/0209690	A1	10/2004	Bruzzese
2003/0162594	A1	8/2003	Rowe	2004/0219961	A1	11/2004	Ellenby
2003/0165293	A1	9/2003	Abeles et al.	2004/0224769	A1	11/2004	Hansen
2003/0173408	A1	9/2003	Mosher et al.	2004/0225565	A1	11/2004	Selman
2003/0176162	A1	9/2003	Planki	2004/0229685	A1	11/2004	Smith
2003/0176218	A1	9/2003	Lemay	2004/0229699	A1	11/2004	Gentles et al.
2003/0177187	A1	9/2003	Levine et al.	2004/0242297	A1	12/2004	Walker
2003/0177347	A1	9/2003	Schneier et al.	2004/0242322	A1	12/2004	Montagne
2003/0190944	A1	10/2003	Manfredi et al.	2004/0242332	A1	12/2004	Walker et al.
2003/0195037	A1	10/2003	Voung et al.	2004/0243504	A1	12/2004	Asher et al.
2003/0195043	A1	10/2003	Shinners et al.	2004/0248637	A1	12/2004	Liebenberg et al.
2003/0195841	A1	10/2003	Ginsberg et al.	2004/0248653	A1	12/2004	Barros et al.
2003/0208684	A1	11/2003	Camacho et al.	2004/0259626	A1	12/2004	Akram
2003/0212996	A1	11/2003	Wolzien	2004/0259631	A1	12/2004	Katz et al.
				2004/0260647	A1	12/2004	Blinn
				2004/0266533	A1	12/2004	Gentles et al.
				2005/0001711	A1	1/2005	Doughty et al.
				2005/0003881	A1	1/2005	Byng

(56)		References Cited	
U.S. PATENT DOCUMENTS			
2005/0003888	A1	1/2005	Asher et al.
2005/0003893	A1	1/2005	Hogwood et al.
2005/0009600	A1	1/2005	Rowe et al.
2005/0014554	A1	1/2005	Walker et al.
2005/0020336	A1	1/2005	Cesare
2005/0020340	A1	1/2005	Cannon
2005/0026670	A1	2/2005	Lardie
2005/0026697	A1	2/2005	Balahura
2005/0027643	A1	2/2005	Amaitis et al.
2005/0043996	A1	2/2005	Silver
2005/0049022	A1	3/2005	Mullen
2005/0049949	A1	3/2005	Asher et al.
2005/0054439	A1	3/2005	Rowe et al.
2005/0059397	A1	3/2005	Zhao
2005/0059485	A1	3/2005	Paulsen
2005/0064934	A1	3/2005	Amaitis et al.
2005/0071481	A1	3/2005	Danieli
2005/0086301	A1	4/2005	Eichler et al.
2005/0090294	A1	4/2005	Narasimhan
2005/0096109	A1	5/2005	McNutt et al.
2005/0096133	A1	5/2005	Hoefelmeyer et al.
2005/0101383	A1	5/2005	Wells
2005/0107022	A1	5/2005	Wichelmann
2005/0107156	A1	5/2005	Potts et al.
2005/0108365	A1	5/2005	Becker et al.
2005/0113172	A1	5/2005	Gong
2005/0116020	A1	6/2005	Smolucha et al.
2005/0130677	A1	6/2005	Meunier et al.
2005/0130728	A1	6/2005	Ngyuen
2005/0131815	A1	6/2005	Fung et al.
2005/0137014	A1	6/2005	Vetelainen
2005/0143169	A1	6/2005	Ngyuen et al.
2005/0144484	A1	6/2005	Wakayama
2005/0159212	A1	7/2005	Romney et al.
2005/0170845	A1	8/2005	Moran
2005/0170886	A1	8/2005	Miller
2005/0170890	A1	8/2005	Rowe et al.
2005/0170892	A1	8/2005	Atkinson
2005/0181859	A1	8/2005	Lind et al.
2005/0181862	A1	8/2005	Asher et al.
2005/0181870	A1	8/2005	Nguyen et al.
2005/0187000	A1	8/2005	Miller
2005/0187020	A1	8/2005	Amaitis et al.
2005/0190901	A1	9/2005	Oborn et al.
2005/0192077	A1	9/2005	Okuniewicz
2005/0193118	A1	9/2005	Le et al.
2005/0193209	A1	9/2005	Saunders et al.
2005/0197189	A1	9/2005	Schultz
2005/0197190	A1	9/2005	Amaitis et al.
2005/0209002	A1	9/2005	Blythe et al.
2005/0215306	A1	9/2005	O'Donnell et al.
2005/0225437	A1	10/2005	Shiotsu
2005/0234774	A1	10/2005	Dupree
2005/0239523	A1	10/2005	Longman et al.
2005/0239524	A1	10/2005	Longman et al.
2005/0239546	A1	10/2005	Hedrick et al.
2005/0243774	A1	10/2005	Dupree
2005/0245306	A1	11/2005	Asher et al.
2005/0245308	A1	11/2005	Amaitis et al.
2005/0251440	A1	11/2005	Bednarek
2005/0261061	A1	11/2005	Nguyen et al.
2005/0277471	A1	12/2005	Russell et al.
2005/0277472	A1	12/2005	Gillan et al.
2005/0282638	A1	12/2005	Rowe et al.
2005/0288937	A1	12/2005	Verdiramo
2006/0005050	A1	1/2006	Basson et al.
2006/0009279	A1	1/2006	Amaitis et al.
2006/0016877	A1	1/2006	Bonalle et al.
2006/0019745	A1	1/2006	Benbrahim
2006/0121987	A1	1/2006	Bortnik et al.
2006/0035707	A1*	2/2006	Nguyen ..... G07F 17/32 463/29
2006/0040717	A1	2/2006	Lind et al.
2006/0040741	A1	2/2006	Grisworld et al.
2006/0052153	A1	3/2006	Vlazny et al.
2006/0058102	A1	3/2006	Nguyen et al.
2006/0068917	A1	3/2006	Snoddy et al.
2006/0069711	A1	3/2006	Tsunekawa et al.
2006/0076406	A1	4/2006	Frerking
2006/0093142	A1	5/2006	Schneier et al.
2006/0095790	A1	5/2006	Nguyen et al.
2006/0100019	A1	5/2006	Hornik et al.
2006/0106736	A1	5/2006	Jung
2006/0116198	A1	6/2006	Leen et al.
2006/0116199	A1	6/2006	Leen et al.
2006/0116200	A1	6/2006	Leen et al.
2006/0121970	A1	6/2006	Khal
2006/0129432	A1*	6/2006	Choi ..... A61B 5/002 705/3
2006/0131391	A1	6/2006	Penuela
2006/0135252	A1	6/2006	Amaitis et al.
2006/0135259	A1	6/2006	Nancke-Krogh et al.
2006/0136296	A1	6/2006	Amada
2006/0148560	A1	7/2006	Arezina et al.
2006/0148561	A1	7/2006	Moser
2006/0160626	A1	7/2006	Gatto et al.
2006/0163346	A1	7/2006	Lee et al.
2006/0165235	A1	7/2006	Carlson
2006/0166740	A1	7/2006	Sufuentes
2006/0173754	A1	8/2006	Burton et al.
2006/0178216	A1	8/2006	Shea et al.
2006/0183522	A1	8/2006	Leen et al.
2006/0184417	A1	8/2006	Van der Linden et al.
2006/0187029	A1	8/2006	Thomas
2006/0189382	A1	8/2006	Muir et al.
2006/0194589	A1	8/2006	Saniska
2006/0199649	A1	9/2006	Soltys et al.
2006/0200463	A1*	9/2006	Dettinger ..... G06F 16/20
2006/0205489	A1	9/2006	Carpenter et al.
2006/0205497	A1	9/2006	Wells et al.
2006/0209810	A1	9/2006	Krzyzanowski et al.
2006/0224046	A1	10/2006	Ramadas et al.
2006/0229520	A1	10/2006	Yamashita
2006/0234631	A1	10/2006	Dieguez
2006/0234791	A1	10/2006	Nguyen et al.
2006/0236395	A1	10/2006	Barker et al.
2006/0246990	A1	11/2006	Downes
2006/0247026	A1	11/2006	Walker et al.
2006/0247039	A1	11/2006	Lerner et al.
2006/0247041	A1	11/2006	Walker et al.
2006/0247053	A1	11/2006	Mattila
2006/0252501	A1	11/2006	Little et al.
2006/0252530	A1	11/2006	Oberberger et al.
2006/0258429	A1	11/2006	Manning et al.
2006/0277098	A1	12/2006	Chung et al.
2006/0277308	A1	12/2006	Morse et al.
2006/0277413	A1	12/2006	Drews
2006/0287092	A1	12/2006	Walker et al.
2006/0287098	A1	12/2006	Morrow et al.
2006/0293965	A1	12/2006	Burton
2007/0001841	A1	1/2007	Anders et al.
2007/0003034	A1	1/2007	Schultz et al.
2007/0015564	A1	1/2007	Walker et al.
2007/0021213	A1	1/2007	Foe et al.
2007/0026939	A1	2/2007	Asher et al.
2007/0030154	A1	2/2007	Aiki et al.
2007/0032301	A1	2/2007	Acres et al.
2007/0054739	A1	3/2007	Amaitis et al.
2007/0060305	A1	3/2007	Amaitis et al.
2007/0060306	A1	3/2007	Amaitis et al.
2007/0060312	A1	3/2007	Dempsey et al.
2007/0060326	A1	3/2007	Juds et al.
2007/0060355	A1	3/2007	Amaitis et al.
2007/0060358	A1	3/2007	Amaitis et al.
2007/0066401	A1	3/2007	Amaitis
2007/0066402	A1	3/2007	Amaitis
2007/0087834	A1	4/2007	Moser et al.
2007/0087843	A1	4/2007	Steil et al.
2007/0093296	A1	4/2007	Asher et al.
2007/0099697	A1	5/2007	Nelson
2007/0099703	A1	5/2007	Terebilo
2007/0117604	A1	5/2007	Hill
2007/0117634	A1	5/2007	Hamilton et al.
2007/0130044	A1	6/2007	Rowan

(56)

References Cited

U.S. PATENT DOCUMENTS

2007/0136817 A1 6/2007 Ngyuen  
 2007/0167237 A1 7/2007 Wang et al.  
 2007/0168570 A1 7/2007 Martin et al.  
 2007/0181676 A1 8/2007 Mateen et al.  
 2007/0190494 A1 8/2007 Rosenberg  
 2007/0191719 A1 8/2007 Yamashita et al.  
 2007/0213120 A1 9/2007 Beal et al.  
 2007/0233585 A1 10/2007 Ben Simon et al.  
 2007/0235807 A1 10/2007 Sobel et al.  
 2007/0238443 A1 10/2007 Richardson  
 2007/0241187 A1 10/2007 Alderucci et al.  
 2007/0243927 A1 10/2007 Soltys  
 2007/0243935 A1 10/2007 Huizinga  
 2007/0257101 A1 11/2007 Alderucci et al.  
 2007/0258507 A1 11/2007 Lee et al.  
 2007/0259717 A1 11/2007 Mattice et al.  
 2007/0275779 A1 11/2007 Amaitis  
 2007/0281782 A1 12/2007 Amaitis  
 2007/0281785 A1 12/2007 Amaitis  
 2007/0281792 A1 12/2007 Amaitis  
 2007/0282959 A1 12/2007 Stern  
 2008/0004121 A1 1/2008 Gatto et al.  
 2008/0009344 A1 1/2008 Graham et al.  
 2008/0015013 A1 1/2008 Gelman et al.  
 2008/0022089 A1 1/2008 Leedom  
 2008/0026829 A1 1/2008 Martin et al.  
 2008/0026844 A1 1/2008 Wells et al.  
 2008/0032801 A1 2/2008 Brunet de Courssou  
 2008/0039196 A1 2/2008 Walther et al.  
 2008/0051193 A1 2/2008 Kaminkow et al.  
 2008/0066111 A1 3/2008 Ellis et al.  
 2008/0076505 A1 3/2008 Nguyen et al.  
 2008/0076506 A1 3/2008 Nguyen et al.  
 2008/0076572 A1 3/2008 Nguyen et al.  
 2008/0096628 A1 4/2008 Czyzewski et al.  
 2008/0096659 A1 4/2008 Kreloff et al.  
 2008/0102956 A1 5/2008 Burman et al.  
 2008/0102957 A1 5/2008 Burman et al.  
 2008/0108370 A1\* 5/2008 Aninye ..... B60R 25/1004  
 455/456.1  
 2008/0108423 A1 5/2008 Benbrahim et al.  
 2008/0113785 A1 5/2008 Alderucci et al.  
 2008/0113786 A1 5/2008 Alderucci et al.  
 2008/0113787 A1 5/2008 Alderucci et al.  
 2008/0113816 A1 5/2008 Mahaffey et al.  
 2008/0132251 A1 6/2008 Altman et al.  
 2008/0139306 A1 6/2008 Lutnick  
 2008/0146323 A1 6/2008 Hardy et al.  
 2008/0147546 A1 6/2008 Weichselbaumer  
 2008/0150678 A1 6/2008 Giobbi et al.  
 2008/0182644 A1 7/2008 Lutnick et al.  
 2008/0195664 A1 8/2008 Maharajh et al.  
 2008/0207302 A1 8/2008 Lind et al.  
 2008/0214261 A1 9/2008 Alderucci et al.  
 2008/0218312 A1 9/2008 Asher et al.  
 2008/0220871 A1 9/2008 Asher et al.  
 2008/0221396 A1 9/2008 Graces et al.  
 2008/0221714 A1\* 9/2008 Schoettle ..... H04L 12/2829  
 700/90  
 2008/0224822 A1 9/2008 Asher et al.  
 2008/0254897 A1 10/2008 Saunders et al.  
 2008/0305856 A1 12/2008 Walker et al.  
 2008/0305867 A1 12/2008 Guthrie  
 2008/0311994 A1 12/2008 Amaitis et al.  
 2008/0318670 A1 12/2008 Zinder et al.  
 2009/0049542 A1 2/2009 DeYonker et al.  
 2009/0055204 A1 2/2009 Pennington et al.  
 2009/0088232 A1 4/2009 Amaitis et al.  
 2009/0098925 A1 4/2009 Gagner et al.  
 2009/0117989 A1 5/2009 Arezina et al.  
 2009/0149233 A1 6/2009 Strause et al.  
 2009/0163272 A1 6/2009 Baker et al.  
 2009/0178118 A1 7/2009 Cedo et al.  
 2009/0183208 A1 7/2009 Christensen et al.  
 2009/0197684 A1 8/2009 Arezina et al.

2009/0204905 A1 8/2009 Toghia  
 2009/0209233 A1 8/2009 Morrison  
 2009/0312032 A1 12/2009 Bornstein et al.  
 2009/0325708 A9 12/2009 Kerr  
 2010/0023372 A1 1/2010 Gonzalez  
 2010/0062834 A1 3/2010 Ryan  
 2010/0069144 A1 3/2010 Curtis  
 2010/0069158 A1 3/2010 Kim  
 2010/0075760 A1 3/2010 Shimabukuro et al.  
 2010/0113143 A1 5/2010 Gagner et al.  
 2010/0127919 A1 5/2010 Curran et al.  
 2010/0153511 A1 6/2010 Lin  
 2010/0205255 A1 8/2010 Alderucci  
 2010/0211431 A1 8/2010 Lutnick  
 2010/0227691 A1 9/2010 Karsten  
 2010/0240455 A1 9/2010 Gagner et al.  
 2011/0269520 A1 11/2011 Amaitis et al.  
 2011/0269532 A1 11/2011 Shuster et al.  
 2012/0190452 A1 7/2012 Weston et al.  
 2013/0005486 A1 1/2013 Amaitis et al.  
 2013/0065672 A1 3/2013 Gelman et al.  
 2013/0065679 A1 3/2013 Gelman et al.  
 2013/0072295 A1 3/2013 Alderucci et al.  
 2013/0084933 A1 4/2013 Amaitis et al.  
 2013/0084968 A1 4/2013 Bernsen  
 2013/0165212 A1 6/2013 Amaitis et al.  
 2013/0165213 A1 6/2013 Alderucci et al.  
 2013/0165221 A1 6/2013 Alderucci et al.  
 2013/0178277 A1 7/2013 Burman et al.  
 2013/0210513 A1 8/2013 Nguyen  
 2013/0244742 A1 9/2013 Amaitis et al.  
 2014/0057724 A1 2/2014 Alderucci et al.  
 2014/0113707 A1 4/2014 Asher et al.  
 2014/0200465 A1 7/2014 McIntyre  
 2014/0288401 A1 9/2014 Ouwekerk  
 2014/0300491 A1 10/2014 Chen  
 2015/0080111 A1 3/2015 Amaitis et al.  
 2015/0141131 A1 5/2015 Gelman et al.  
 2015/0243135 A1 8/2015 Lutnick et al.  
 2020/0098222 A1 3/2020 Alderucci et al.

FOREIGN PATENT DOCUMENTS

DE 37 36 770 A1 5/1989  
 DE 43 16 652 A1 11/1994  
 DE 0 840 639 B1 7/1996  
 DE 0 506 873 B1 3/2000  
 DE 19922862 12/2000  
 DE 1 066 868 A2 1/2001  
 DE 19944140 3/2001  
 DE 19952691 5/2001  
 DE 19952692 5/2001  
 DE 1 202 528 A3 5/2002  
 DE 10060079 6/2002  
 DE 1 475 755 A1 12/2003  
 DE 1 475 756 A2 11/2004  
 DE 1 531 646 A1 5/2005  
 EP 1045346 10/2000  
 EP 1063622 12/2000  
 EP 1066867 1/2001  
 EP 1120757 1/2001  
 EP 1217792 6/2002  
 EP 1231577 8/2002  
 EP 1480102 A2 11/2004  
 GB 2 248 404 4/1992  
 GB 2 256 594 12/1992  
 GB 2 391 432 2/2004  
 GB 2 391 767 2/2004  
 GB 2394675 5/2004  
 JP H11-220766 1/1988  
 JP 5-317485 12/1993  
 JP H07-281780 10/1995  
 JP 2000-69540 8/1998  
 JP 2000-160016 6/2000  
 JP 2001-70658 3/2001  
 JP 2001-204971 7/2001  
 JP 2001-204972 7/2001  
 JP 2001/212363 8/2001  
 JP 2001 236458 8/2001

(56)

## References Cited

## FOREIGN PATENT DOCUMENTS

- |    |                   |         |
|----|-------------------|---------|
| JP | 2001-340656       | 12/2001 |
| JP | 2001-344400       | 12/2001 |
| JP | 2001-526550       | 12/2001 |
| JP | 2002-032515       | 1/2002  |
| JP | 2002-049681       | 2/2002  |
| JP | 2002-056270       | 2/2002  |
| JP | 2002107224        | 2/2002  |
| JP | 2002-109376       | 4/2002  |
| JP | 2002-66144        | 5/2002  |
| JP | 2002-133009       | 5/2002  |
| JP | 2002-135468       | 5/2002  |
| JP | 2002-175296       | 6/2002  |
| JP | 2002-189831       | 7/2002  |
| JP | 2002-253866       | 9/2002  |
| JP | 2002-263375       | 9/2002  |
| JP | 2002-292113       | 10/2002 |
| JP | 2003-053042       | 2/2003  |
| JP | 2003-062353       | 3/2003  |
| JP | 2003-078591       | 3/2003  |
| JP | 2003-518677       | 6/2003  |
| JP | 2003-210831       | 7/2003  |
| JP | 2003-210852       | 7/2003  |
| JP | 2002-149894       | 5/2004  |
| JP | 2004-261202       | 9/2004  |
| JP | 2004-321558       | 11/2004 |
| JP | 2004-536638       | 12/2004 |
| JP | 2005-073711       | 3/2005  |
| JP | 2006-072468       | 3/2006  |
| JP | 2007-011420       | 1/2007  |
| JP | 5639328           | 10/2014 |
| RU | 2190477           | 10/2002 |
| WO | WO 1993/010508    | 5/1993  |
| WO | WO 1994/010658    | 5/1994  |
| WO | WO 1994/016416    | 7/1994  |
| WO | WO 95/24689       | 9/1995  |
| WO | WO 1997/019537    | 5/1997  |
| WO | WO 1997/044750    | 11/1997 |
| WO | WO 99/04873 A1    | 2/1999  |
| WO | WO 99/08762 A1    | 2/1999  |
| WO | WO 1999/019027    | 4/1999  |
| WO | WO 1999/042964    | 8/1999  |
| WO | WO 1999/052077    | 10/1999 |
| WO | WO 1999/055102    | 10/1999 |
| WO | WO 00/77753 A1    | 12/2000 |
| WO | WO 2001/017262 A1 | 3/2001  |
| WO | WO 01/40978 A2    | 6/2001  |
| WO | WO 01/48712 A1    | 7/2001  |
| WO | WO 2001/048713    | 7/2001  |
| WO | WO 2001/054091    | 7/2001  |
| WO | WO 2001/067218    | 9/2001  |
| WO | WO 01/77861       | 10/2001 |
| WO | WO 01/84817 A1    | 11/2001 |
| WO | WO 01/89233 A3    | 11/2001 |
| WO | WO 2001/082176    | 11/2001 |
| WO | WO 02/10931 A1    | 2/2002  |
| WO | WO 02/21457 A1    | 3/2002  |
| WO | WO 2002/031739    | 4/2002  |
| WO | WO 02/39605 A1    | 5/2002  |
| WO | WO 02/41199 A3    | 5/2002  |
| WO | WO 2002/037246    | 5/2002  |
| WO | WO 02/47022       | 6/2002  |
| WO | WO 2002/047042    | 6/2002  |
| WO | WO 2002/065750 A2 | 8/2002  |
| WO | WO 2002/071351 A2 | 9/2002  |
| WO | WO 2002/077931 A1 | 10/2002 |
| WO | WO 2002/101486    | 12/2002 |
| WO | WO 2003/005743    | 1/2003  |
| WO | WO 2003/013678 A1 | 2/2003  |
| WO | WO 2003/021543    | 3/2003  |
| WO | WO 2003/027970 A2 | 4/2003  |
| WO | WO 2003/045519    | 6/2003  |
| WO | WO 2003/081447    | 10/2003 |
| WO | WO 2004/003810 A1 | 1/2004  |
| WO | WO 2004/013820    | 2/2004  |
| WO | WO 2004/014506 A1 | 2/2004  |
| WO | WO 2004/023253 A3 | 3/2004  |
| WO | WO 2004/027689    | 4/2004  |
| WO | WO 2004/034223    | 4/2004  |
| WO | WO 2004/073812 A2 | 9/2004  |
| WO | WO 2004/095383    | 11/2004 |
| WO | WO 2004/104763 A2 | 12/2004 |
| WO | WO 2004/109321    | 12/2004 |
| WO | WO 2004/114235 A1 | 12/2004 |
| WO | WO 2005/001651    | 1/2005  |
| WO | WO 2005/015458 A1 | 2/2005  |
| WO | WO 2005/022453    | 3/2005  |
| WO | WO 2005/026870 A2 | 3/2005  |
| WO | WO 2005/031627 A1 | 4/2005  |
| WO | WO 2005/031666 A1 | 4/2005  |
| WO | WO 2005/036425 A1 | 4/2005  |
| WO | WO 2005/082011    | 9/2005  |
| WO | WO 2005/085980    | 9/2005  |
| WO | WO 2005/098650    | 10/2005 |
| WO | WO 2006/023230    | 3/2006  |
| WO | WO 2007/008601 A2 | 1/2007  |
| WO | WO 2008/005264    | 1/2008  |
| WO | WO 2008/016610    | 2/2008  |

## OTHER PUBLICATIONS

- U.S. Office Action for U.S. Appl. No. 11/199,835, filed Aug. 9, 2005; 17 pages; dated Mar. 2, 2007.
- Janna Lindsjö, et al.; *GIGANT—an Interactive, Social, Physical and Mobile Game*; PDC 2002 Proceedings of the Participatory Design Conference; Malmö, Sweden; 5 pages; Jun. 23-25, 2002.
- Stephan Neuert, et al.; The British Library; *Delivering Seamless Mobile Services Over Bluetooth*; 11 pages; Oct. 2002.
- Business Wire; *Home Gambling Network Inc., With U.S. Pat. No. 5,800,268—Business/Gambling—HGN and UUNET, a WorldCom/MCI Company, Reach a Mutually Satisfactory Resolution in Patent Suit*; 2 pages; Mar. 19, 1999.
- PR Newswire; *Nokia N-Gage (TM) Mobile Game Deck—The Revolutionary Gaming Experience; Major Global Games Publishers Excited to Publish on Wireless Multiplayer Platform*; 3 pages; Feb. 6, 2003.
- Business Wire; *GoldPocket Interactive Launches EM Mobile Matrix, Industry's First Fully Synchronous Interactive Television and Massively Multi-Player Gaming Solution*; 2 pages; Mar. 17, 2003.
- Brand Strategy; *The National Lottery has announced that UK consumers will be able to purchase tickets using the internet, TV and Mobile phones. (Launches & Rebrands)*; ISSN 0965-9390; 1 page; 04/00/2003.
- PR Newswire; *Ideaworks3D appointed by Eidos Interactive to Develop Blockbuster Line-up for Nokia N-Gage Mobile Game Deck*; 2 pages; May 23, 2003.
- Telecomworldwire; *New mobile lottery service launched by mLotto*; 1 page; Oct. 30, 2003.
- Singh, et al.; *Anywhere, Any-Device Gaming*; Human Interface Technology Laboratory; National University of Singapore; 4 pages; 2004.
- Wu, et al; The Electronic Library; *Real Tournament—Mobile Context-Aware Gaming for the Next Generation*; vol. 22; No. 1; ISBN 0-86176-934-1; ISSN 0264-0473; 11 pages; 2004.
- Precision Marketing; vol. 16, No. 11; ISSN 0955-0836; 2 pages; Jan. 9, 2004.
- Online Reporter; *GTECH Takes Lottery Mobile*; 1 page; Feb. 28, 2004.
- Personal and Ubiquitous Computing; *Human Pacman: a mobile, wide-area entertainment system based on physical, social, and ubiquitous computing*; 12 pages; May 2004.
- PR Newswire; *M7 Networks Partners With Terraplay to Deliver Real-Time Multiplayer Gaming Functionality to Its Community Services Offerings*; 2 pages; Jun. 1, 2004.
- China Telecom; *Win Win Gaming Inc. announces agreement to provide wireless lottery and entertainment content in Shanghai*; vol. 11, No. 9; 2 pages; 09/00/2004.
- Business Wire; *EA Announces Next Step Into Mobile Gaming; Digital Bridges Named as Strategic Partner for Distribution of Mobile Interactive Entertainment in Europe, North and South America*; 3 pages; Sep. 2, 2004.



(56)

**References Cited**

## OTHER PUBLICATIONS

Wireless News; Mobile Casinos, Lotteries Good News for Mobile Revenues; 2 pages; Feb. 23, 2005.

Business Wire; MobileGamingNow, Inc. Announces the Launch of the First Ever Mobile Phone Interactive, Multi-Player Gaming System for Poker; 2 pages; Apr. 4, 2005.

Business Wire; InfoSpace's Golf Club 3D Scores Hole-in-One for Exciting and Realistic Game Play; InfoSpace's 3D Golf Captures the Challenge and Realism of the Sport With Real-Time 3D Animation, Weather Effects, and Customizable Characters; 2 pages; Apr. 21, 2005.

Business Wire; July Systems' Play2Win Interactive Game Service Launched on UK's MobileGaming.com; Speedy Customer Deployments Now Possible With July's New UK Mobile Retailing Infrastructure; 2 pages; May 4, 2005.

Gaming Labs Certified™; Standard Series; GLI-26: Wireless Gaming System Standards; Version: 1.1; 28 pages; Jan. 18, 2007.

Notification of Transmittal of the International Search Report and the Written Opinion of the International Searching Authority, or the Declaration, for International Application No. PCT/US06/26343, 8 pages, dated Jan. 19, 2007.

Gaming Labs Certified™; Standard Series; GLI-11: Gaming Devices in Casinos; Version: 2.0; 96 pages; Apr. 20, 2007.

Notification of Transmittal of the International Search Report and the Written Opinion of the International Searching Authority, or the Declaration for International Application No. PCT/US06/26350, 8 pages, dated Apr. 27, 2007.

Gaming Labs Certified™; Standard Series; GLI-21: Client-Server Systems; Version: 2.1; 85 pages; May 18, 2007.

USPTO Office Action for U.S. Appl. No. 11/418,939, dated Dec. 17, 2007 (13 pages).

USPTO Office Action for U.S. Appl. No. 11/418,939, dated Aug. 20, 2008 (12 pages).

USPTO Office Action for U.S. Appl. No. 11/418,939, dated Apr. 10, 2007.

PCT Notification of Transmittal of the International Search Report and the Written Opinion of the International Searching Authority for International Application No. PCT/US07/66873; 4 pages; dated Aug 4, 2008.

PCT Notification of Transmittal of the International Search Report and the Written Opinion of the International Searching Authority for International Application No. PCT/US2008/057239; 8 pages; dated Aug. 7, 2008.

U.S. PTO Office Action for U.S. Appl. No. 11/199,831; 9 pages; dated Dec. 19, 2008.

U.S. PTO Office Action for U.S. Appl. No. 11/406,783; dated Feb. 9, 2009.

U.S. PTO Office Action for U.S. Appl. No. 11/686,354; dated Oct. 1, 2009; 9 pages.

Notice of Allowance for U.S. Appl. No. 11/406,783; 6 pages; dated Sep. 28, 2009.

Notice of Allowance for U.S. Appl. No. 11/199,831; 5 pages; dated Oct. 21, 2009.

USPTO Office Action for U.S. Appl. No. 11/559,829, dated Nov. 3, 2009, 22 pp.

USPTO Office Action for U.S. Appl. No. 11/559,933, dated Oct. 20, 2009, 17 pp.

USPTO Office Action for U.S. Appl. No. 11/559,484, dated Nov. 3, 2009, 31 pp.

Notice of Allowance for U.S. Appl. No. 11/686,354; dated Apr. 29, 2010; 6 pages.

Notice of Allowability for U.S. Appl. No. 11/199,835; dated Apr. 10, 2009; 2 pages.

AU Examination Report for AU Application No. 2006269413; 2 pages; dated Apr. 29, 2009.

Canadian Examination Report for CA Application No. 2613335; 4 pages; dated Mar. 29, 2010.

AU Examination Report for AU Application No. 2007216729; 5 pages; dated Jan. 16, 2009.

U.S. PTO Office Action for U.S. Appl. No. 11/559,829; 29 pages; dated Jun. 22, 2010.

AU Examination Report for AU Application No. 2007319235; dated Jul. 6, 2010; 2 pages.

AU Examination Report for AU Application No. 2006269416; 4 pages; dated Jun. 10, 2009.

U.S. PTO Office Action for U.S. Appl. No. 11/559,484; 19 pages; dated Jul. 20, 2010.

U.S. PTO Office Action for U.S. Appl. No. 11/559,933; 37 pages; dated Jul. 20, 2010.

CA Examination Report for CA Application No. 2613333; dated Aug. 30, 2010; 4 pages.

NZ Examination Report for NZ Application No. 577177; dated Dec. 17, 2010; 2 pages.

CA Examination report for CA Application No. 2596474; dated Nov. 15, 2010; 6 pages.

UK Office Action for Application No. 0910202.1 dated Dec. 21, 2010; 7 pages.

Notice of Allowance for U.S. Appl. No. 11/686,354; dated Mar. 3, 2011; 8 pages.

U.S. PTO Office Action for U.S. Appl. No. 12/247,623; 10 pages; dated Mar. 21, 2011.

Notice of Acceptance for AU Application No. 2006269416 dated Mar. 9, 2011; 3 pages.

Notice of Acceptance for CA Application No. 2613335 dated Apr. 4, 2011; 1 pages.

JP Office Action for Application No. 2008-520391; dated Feb. 1, 2011; 7 pages total with English Translation.

Notice of Acceptance for AU Application No. 2006269413 dated Feb. 7, 2011; 3 pages.

JP Office Action for Application No. 2008-520389; dated Jan. 18, 2011; 6 pages total with English Translation.

Notice of Allowance for U.S. Appl. No. 11/559,484; 8 pages; dated Nov. 23, 2010.

Notice of Allowance for U.S. Appl. No. 11/418,939; 27 pages; dated Mar. 9, 2009.

AU Examination Report for Application No. 2010214792 dated May 18, 2011; 2 pages.

EP Office Action for Application No. 07760844.6 dated Jan. 5, 2009; 7 pages.

Notice of Acceptance for Application No. 2010214792 dated Aug. 3, 2011; 3 pages.

U.S. PTO Office Action for U.S. Appl. No. 12/324,221; 13 pages; dated Aug. 10, 2011.

U.S. PTO Office Action for U.S. Appl. No. 12/324,269; 14 pages; dated Aug. 15, 2011.

U.S. PTO Office Action for U.S. Appl. No. 12/324,355; 14 pages; dated Aug. 18, 2011.

Notice of Allowance for U.S. Appl. No. 11/559,484; 8 pages; dated Jun. 20, 2011.

GB Office Action for Application No. GB0910202.1; 4 pages; dated Jul. 11, 2011.

Notice of Allowance for CA Application No. 2613333; 1 pages; dated Jul. 20, 2011.

Notice of Allowance for U.S. Appl. No. 12/324,221; 7 pages; dated Dec. 28, 2011.

Notice of Allowance for U.S. Appl. No. 12/324,269; 7 pages; dated Dec. 6, 2011.

Notice of Allowance for U.S. Appl. No. 12/324,355; 7 pages; dated Dec. 12, 2011.

AU Examination Report for Application No. 2011202267; 2 pages; dated Nov. 30, 2011.

Notice of Allowance for U.S. Appl. No. 11/559,484; 8 pages; dated Dec. 13, 2011.

Notice of Allowance for U.S. Appl. No. 12/247,623; dated Jan. 24, 2012; 8 pages.

U.S. PTO Office Action for U.S. Appl. No. 12/647,887; dated Jan. 23, 2012; 11 pages.

Notice of Allowance for U.S. Appl. No. 11/559,829; dated Jan. 10, 2012; 14 pages.

U.S. PTO Office Action for U.S. Appl. No. 12/792,361; dated Feb. 13, 2012; 14 pages.

(56)

**References Cited**

## OTHER PUBLICATIONS

Extended EP Search report for Application No. 07871467.2; dated Feb. 8, 2012; 8 pages.

U.S. PTO Office Action for U.S. Appl. No. 12/685,381; 8 pages; dated Feb. 28, 2012.

U.S. PTO Office Action for U.S. Appl. No. 11/559,933; 23 pages; dated Mar. 2, 2012.

JP Office Action for Application No. 2008-520389; dated Jan. 24, 2012; 5 pages (includes English Translation).

AU Examination Report for AU Application No. 2007319235; dated Mar. 13, 2012; 2 pages.

JP Office Action for Application No. 2008-520391; dated Apr. 10, 2012; 6 pages total with English Translation.

Notice of Acceptance for AU Application No. 2011202267; 3 pages; dated Mar. 6, 2012.

Notice of Allowance for U.S. Appl. No. 12/324,269; 9 pages; dated Mar. 22, 2012.

Notice of Allowance for U.S. Appl. No. 11/559,484; 17 pages; dated Jun. 1, 2012.

Notice of Allowance for U.S. Appl. No. 11/559,829; dated May 11, 2012; 10 pages.

AU Examination report for Application No. 2011203051; dated May 28, 2012; 4 pages.

CA Examination Report for Application No. 2754756; 6 pages; dated May 29, 2012.

EP Office Action for Application No. 06786486.8; 5 pages; dated May 14, 2012.

EP Office Action for Application No. 06786483.5; 7 pages; dated May 14, 2012.

Notice of Allowance for U.S. Appl. No. 12/324,355; 10 pages; dated Jun. 15, 2012.

U.S. PTO Office Action for U.S. Appl. No. 12/647,887; dated Aug. 3, 2012; 9 Pages.

NZ Examination Report for NZ Application No. 577177; dated Jun. 29, 2012; 2 pages.

Notice of Allowance for U.S. Appl. No. 12/685,381; 7 pages; dated Sep. 12, 2012.

U.S. PTO Office Action for U.S. Appl. No. 12/792,361; dated Sep. 26, 2012; 14 pages.

U.S. PTO Office Action for U.S. Appl. No. 13/616,356; 8 pages; dated Dec. 4, 2012.

CA Examination report for CA Application No. 2596474; dated Mar. 20, 2012; 1 page.

Notice of Allowance for U.S. Appl. No. 11/559,484; 17 pages; dated Oct. 12, 2012.

U.S. PTO Final Office Action for U.S. Appl. No. 11/559,933; 24 pages; dated Dec. 6, 2012.

AU Examination Report for AU Application No. 2007319235; dated Apr. 16, 2012; 2 pages.

Yampolskiy et al., 2006, "Use of Behavioral Biometrics in Intrusion detection and Online Gaming", Biometric technology for Human Identification III, edited by Patrick J. Flynn, Sharath Pankanti, Proc. of SPIE vol. 6202, 62020U-1-10.

NZ Examination Report for NZ Application No. 577177; dated Oct. 12, 2012; 2 pages.

NZ Examination Report and Notice of Acceptance for NZ Application No. 577177; dated Nov. 6, 2012; 2 pages.

NZ Examination Report for NZ Application No. 600525; dated Jun. 14, 2012; 2 pages.

Notice of Allowance for U.S. Appl. No. 11/559,829; dated Oct. 9, 2012; 9 pages.

Notice of Allowance for U.S. Appl. No. 12/685,381; dated Jan. 9, 2013; 16 pages.

Notice of Allowance for U.S. Appl. No. 12/324,269; 27 pages; dated Oct. 17, 2012.

Notice of Allowance for U.S. Appl. No. 12/324,355; 34 pages; dated Jan. 16, 2013.

Notice of Allowance for U.S. Appl. No. 113/586,142; 8 pages; dated Dec. 24, 2012.

US PTO Office Action for U.S. Appl. No. 13/615,440; 17 pages; dated Jan. 15, 2013.

Notice of Allowance for U.S. Appl. No. 12/647,887; 35 pages; dated Mar. 13, 2013.

JP Office Action for Application No. 2009-506743 dated Jan. 22, 2013; 5 pages.

JP Office Action for Application No. 2009-537329 dated Feb. 26, 2013; 13 pages.

Notice of Allowance for U.S. Appl. No. 11/559,484; 11 pages; dated Mar. 26, 2013.

JP Office Action for Application No. 2008-520389; dated Apr. 9, 2013; 5 pages (includes English Translation).

Notice of Allowance for U.S. Appl. No. 11/559,829; dated Apr. 25, 2013; 13 pages.

Australian Examination Report for AU Application No. 2011250750, 3 pages; dated May 22, 2013.

EP Communication for Application No. 07871467.2; dated Feb. 22, 2013; 7 pages.

JP Decision to Grant a Patent for Application No. 2008-520391, 4 pages; dated Jun. 12, 2013; (w/ English translation).

U.S. Notice of Allowance for U.S. Appl. No. 12/647,887; 9 pages; dated Jun. 7, 2013.

Hiroshi Kakii, Complete illustration for understanding the latest i-mode, Gijutsu-Hyohron Co. Ltd., Sep. 29, 2000. Second Print of the first edition, p. 36-37, 48-49, 62-63, 78-83, 94-95, and 108-111.

U.S. Office Action for U.S. Appl. No. 11/559,933; dated Jul. 15, 2013; 32 pages.

U.S. Office Action for U.S. Appl. No. 13/616,535; dated Jul. 9, 2013; 11 pages.

U.S. Notice of Allowance for U.S. Appl. No. 12/647,887; 6 pages; dated Jul. 19, 2013.

Notice of Allowance for U.S. Appl. No. 12/247,623; dated Aug. 2, 2013; 6 pages.

U.S. Office Action for U.S. Appl. No. 13/616,356; dated Aug. 15, 2013; 11 pages.

Notice of Allowance for U.S. Appl. No. 11/559,829; dated Aug. 23, 2013; 10 pages.

U.S. Office Action for U.S. Appl. No. 13/616,588; dated Aug. 20, 2013; 17 pages.

Notice of Allowance for U.S. Appl. No. 11/559,829; dated Sep. 12, 2013; 10 pages.

U.S. Final Office Action for U.S. Appl. No. 13/615,440; 10 pages; dated Sep. 9, 2013.

U.S. Office Action for U.S. Appl. No. 13/615,981; dated Sep. 13, 2013; 12 pages.

U.S. Office Action for U.S. Appl. No. 13/616,492; dated Sep. 13, 2013; 13 pages.

U.S. Notice of Allowance for U.S. Appl. No. 12/324,221; dated Sep. 20, 2013; 8 pages.

AU Examination Report No. 1 for Application No. 2012201974; dated Oct. 21, 2013; 3 pages.

U.S. Notice of Allowance for U.S. Appl. No. 12/324,269; dated Oct. 30, 2013; 9 pages.

U.S. Notice of Allowance for U.S. Appl. No. 13/586,142; dated Nov. 21, 2013; 7 pages.

CA Examination Report for App. No. 2,754,756; dated Dec. 30, 2013; 3 pages.

U.S. Office Action for U.S. Appl. No. 13/849,690; dated Jan. 14, 2014; 13 pages.

CA Examination Report for App. No. 2,596,474; dated Dec. 17, 2013; 2 pages.

NZ Examination Report for App. No. 618654; dated Dec. 20, 2013; 2 pages.

EP Examination Report for App. No. 06786486.8; dated Jan. 16, 2014; 5 pages.

EP Examination Report for App. No. 06786483.5; dated Jan. 16, 2014; 5 pages.

U.S. Office Action for U.S. Appl. No. 11/686,354; dated Feb. 25, 2014; 10 pages.

AU Examination Report No. 1 for App. No. 2012258503; dated Feb. 24, 2014; 2 pages.

U.S. Final Office Action for U.S. Appl. No. 13/616,356; dated Mar. 6, 2014; 13 pages.

(56)

**References Cited**

## OTHER PUBLICATIONS

U.S. Office Action for U.S. Appl. No. 12/792,361; dated Mar. 7, 2014; 13 pages.

EP Decision to Refuse a European Patent for App. No. 07871467.2; dated Mar. 3, 2014; 20 pages.

CA Examiners Report for App. No. 2,669,836; dated Feb. 24, 2014; 2 pages.

U.S. Final Office Action for U.S. Appl. No. 13/616,535; dated May 8, 2014; 8 pages.

U.S. Final Office Action for U.S. Appl. No. 13/616,492; dated May 15, 2014; 36 pages.

U.S. Final Office Action for U.S. Appl. No. 11/559,933; dated May 21, 2014; 38 pages.

U.S. Final Office Action for U.S. Appl. No. 13/616,588; dated May 15, 2014; 31 pages.

U.S. Notice of Allowance for U.S. Appl. No. 13/615,440; dated May 12, 2014; 7 pages.

JP Final Notification for Reasons for Refusal for App. No. 2009-506743; dated May 7, 2014; 4 pages (w/English translation).

U.S. Notice of Allowance for U.S. Appl. No. 13/616,535; dated May 30, 2014; 11 pages.

U.S. Office Action for U.S. Appl. No. 13/615,981; dated Jun. 24, 2014; 13 pages.

CA Examiner's Requisition for App. No. 2,754,756; dated Sep. 3, 2014; 3 pages.

CA Examiner's Requisition for App. No. 2,669,836; dated Mar. 13, 2015; 4 pages.

CA Examiners Requisition for App. No. 2,754,756; dated May 12, 2015; 6 pages.

NZ First Examination Report for App. No. 706217; dated Apr. 9, 2015; 2 pages.

JP Final Decision for App. No. 2012-225097; dated Jul. 7, 2015; 12 pages (w/English translation).

JP Final Decision for App. No. 2013-165976; dated Jun. 30, 2015; 6 pages (w/English translation).

EP Communication for App. No. 07760844.6; dated Jun. 23, 2015; 7 pages.

JP Office Action for Application No. 2014-100471 dated Aug. 18, 2015; 6 pages.

JP Office Action for App. No. 2014-161395; dated Aug. 25, 2015; 6 pages (w/English translation).

Personal authentication through biometric technologies, Podio et al, IEEE 2002.

Digital Chips for an on-line casino, Castell'a-Roca et al, IEEE 2005.

AU Patent Examination Report No. for App. No. 2015200884; dated Mar. 15, 2016; 4 pages.

CA Notice of Allowance for App. No. 2,669,836; dated Apr. 6, 2016; 1 page.

AU 1st examination report for AU Application No. 2015203832; dated May 5, 2016; 5 pages.

JP Office Action for App. No. 2014-100471; dated Apr. 12, 2016; 4 pages (w/English translation).

AU First Examination Report for Application No. 2015258347; dated Nov. 11, 2016; 3 pages.

JP Office Action for App. No. 2015-218973; dated Dec. 6, 2016; 9 pages w/English Translations.

Case 2:16-cv-00856-RCJ-VCF, Document 1, "Plaintiffs' Complaint for Patent Infringement" filed Apr. 14, 2016 (39 pages).

Case 2:16-cv-00856-RCJ-VCF, Document 19, "Plaintiffs' First Amended Complaint for Patent Infringement", filed Jul. 11, 2016 (57 pages).

Case 2:16-cv-00856-RCJ-VCF, Document 23, "Defendant 888's Motion to Dismiss Plaintiffs First Amended Complaint Under Fed. R. Civ. P. 12(B)(6)", filed Aug. 12, 2016 (22 pages).

Case 2:16-cv-00856-RCJ-VCF, Document 26, "Defendant's Notice of Joinder to Motions to Dismiss in Related Cases", filed Aug. 12, 2016 (4 pages).

Case 2:16-cv-00856-RCJ-VCF, Document 36, "Plaintiffs' Opposition to 888 Holdings PLC's Motion to Dismiss", filed Sep. 8, 2016 (32 pages).

Case 2:16-cv-00856-RCJ-VCF, Document 37, "Index of Exhibits to Plaintiffs' Opposition to Defendant's Motion to Dismiss" filed Sep. 8, 2016 (3 pages).

Case 2:16-cv-00856-RCJ-VCF, Document 45, Defendant 888's Reply in Support to Dismiss Plaintiffs' First Amended Complaint Under Fed. R. Civ. P. 12(B)(6), filed Sep. 26, 2016 (19 pages).

Case 2:16-cv-00856-RCJ-VCF, Document 46, Defendant 888's Reply in Support of Motion to Dismiss Plaintiffs' First Amended Complaint Under Fed. R. Civ. P. 12(B)(6), filed Sep. 26, 2016 (19 pages).

Case 2:16-cv-00856-RCJ-VCF, Document 54, "Order", filed Dec. 6, 2016 (8 pages).

Case 2:16-cv-00856-RCJ-VCF, Document 57, "Defendant 888's Holdings PLC's Answer to Plaintiffs' First Amended Complaint", filed Jan. 18, 2017 (67 pages).

Case 2:16-cv-00871-JAD-VCF, Document 1, "Plaintiffs' Complaint for Patent Infringement" filed Apr. 15, 2016 (39 pages).

Case 2:16-cv-00871-JAD-VCF, Document 23, "Plaintiffs' First Amended Complaint for Patent Infringement" filed Jul. 11, 2016 (57 pages).

Case 2:16-cv-00871-JAD-VCF, Document 31, "Motion to Dismiss Under 35 U.S.C. §101" filed Aug. 12, 2016 (16 pages).

Case 2:16-cv-00871-RCJ-VCF, Document 35, "Plaintiffs' Opposition to Defendants' Motion to Dismiss" filed Sep. 8, 2016 (25 pages).

Case 2:16-cv-00871-RCJ-VCF, Document 40, "Reply in Support of Motion to Dismiss Under 35 U.S.C. §101" filed Sep. 26, 2016 (14 pages).

Case 2:16-cv-00871-RCJ-VCF, Document 42, "Order" filed Oct. 18, 2016 (15 pages).

Case 2:16-cv-00871-RCJ-VCF, Document 46, "Motion for Reconsideration" filed Oct. 31, 2016 (7 pages).

Case 2:16-cv-00871-RCJ-VCF, Document 47, Motion to Dismiss Under Fed. R. Civ. P. 12(B)(6) filed Nov. 1, 2016 (7 pages).

Case 2:16-cv-00871-RCJ-VCF, Document 49, "Plaintiffs' Opposition to Defendants' Motion for Reconsideration", filed Nov. 17, 2016 (11 pages).

Case 2:16-cv-00871-RCJ-VCF, Document 50, "Plaintiffs' Opposition to Defendants' Motion to Dismiss", filed Nov. 17, 2016 (12 pages).

Case 2:16-cv-00871-RCJ-VCF, Document 55, Reply in Support of Defendants' Motion to Dismiss Under Fed. R. Civ. P. 12(B)(6), filed Nov. 30, 2016 (6 pages).

Case 2:16-cv-00871-RCJ-VCF, Document 56, "Reply in Support of Motion for Reconsideration" filed Nov. 30, 2016 (7 pages).

Case 2:16-cv-00801-JCM-VCF, Document 1, "Plaintiffs' Complaint for Patent Infringement" filed Apr. 8, 2016 (31 pages).

Case 2:16-cv-00801-RCJ-VCF, Document 31, "Plaintiffs' First Amended Complaint for Patent Infringement" filed Jun. 13, 2016 (48 pages).

Case 2:16-cv-00801-RCJ-VCF, Document 32, "Index of Exhibits to Plaintiffs' First Amended Complaint for Patent Infringement" filed Jun. 13, 2016 (3 pages).

Case 2:16-cv-00801-RCJ-VCF Document 44, "Defendant Fanduel, Inc's Motion to Dismiss For Failure to State a Claim Upon Which Relief Can be Granted" filed Jul. 14, 2016 (18 pages).

Case 2:16-cv-00801-RCJ-VCF Document 75, "Defendant Fanduel, Inc's Motion for Leave to Supplement Briefing Under LR 7-2(g)" filed Sep. 22, 2016 (3 pages).

Case 2:16-cv-00801-RCJ-VCF Document 77, "Plaintiffs' Opposition To Defendant Fanduel, Inc.'s Motion For Leave [ECF No. 75]" filed Oct. 11, 2016 (4 pages).

Case 2:16-cv-00801-RCJ-VCF Document 81, "Defendant Fanduel Inc.'s Notice of Withdrawal of Motion Seeking Leave To File Supplemental Briefing" filed Oct. 20, 2016 (3 pages).

Case 2:16-cv-00801-RCJ-VCF Document 86, "Plaintiffs' Second Amended Complaint For Patent Infringement" filed Nov. 16, 2016 (70 pages).

Case 2:16-cv-00801-RCJ-VCF Document 87, "Defendant Fanduel's Answer to Plaintiffs' Second Amended Complaint and Affirmative Defenses" filed Nov. 30, 2016 (19 pages).

(56)

**References Cited**

## OTHER PUBLICATIONS

Case 2:16-cv-00801-RCJ-VCF Document 88, "Defendant's Partial Motion to Dismiss CGT's Second Amended Complaint for Failure to State a Claim Upon Which Relief Can Be Granted" filed Nov. 30, 2016 (14 pages).

Case 2:16-cv-00801-RCJ-VCF Document 94, "Plaintiffs' Opposition to Fanduel, Inc.'s Partial Motion to Dismiss" filed Dec. 19, 2016 (11 pages).

Case 2:16-cv-00801-RCJ-VCF Document 103, "Fanduel, Inc.'s Reply in Support of Partial Motion to Dismiss" filed Dec. 27, 2016 (7 pages).

Case 2:16-cv-00801-RCJ-VCF Document 113, "Order" filed Jan. 4, 2017 (11 pages).

Case 2:16-cv-801-RCJ-VCF Document 114, "Transcript of Pretrial Conference" filed Dec. 2, 2016 (54 pages).

Case 2:16-cv-00781-RFB-CWH, Document 1, "Plaintiffs' Complaint for Patent Infringement" filed Apr. 7, 2016 (33 pages).

Case 2:16-cv-00781-MMD-CWH, Document 29, "Plaintiffs' First Amended Complaint for Patent Infringement" filed Jun. 13, 2016 (42 pages).

Case 2:16-cv-00781-MMD-CWH, Document 37, "Defendant's Motion to Dismiss Plaintiffs' Amended Complaint Under Fed.R. Civ. P. 12(B)(6)" filed Jul. 29, 2016 (38 pages).

Case 2:16-cv-00781-MMD-CWH, Document 44, "Defendant's Motion for Protective Order Staying Discovery Pending Ruling on Motion to Dismiss" filed Aug. 22, 2016 (12 pages).

Case 2:16-cv-00781-MMD-CWH, Document 45, "Plaintiffs' Opposition to DraftKings, Inc.'s Motion to Dismiss" filed Aug. 24, 2016 (38 pages).

Case 2:16-cv-00781-MMD-CWH, Document 50, "Plaintiffs' Opposition to DraftKings, Inc.'s Motion to Stay" filed Sep. 8, 2016 (12 pages).

Case 2:16-cv-00781-MMD-CWH, Document 57, "Defendant's Reply in Support of its Motion to Dismiss Plaintiffs' Amended Complaint Under Fed. R. Civ. P. 12(B)(6)" filed Sep. 26, 2016 (19 pages).

Case 2:16-cv-00781-MMD-CWH, Document 59, "Order" filed Sep. 27, 2016 (3 pages).

Case 2:16-cv-00781-RCJ-VCF, Document 64, "Plaintiffs' Motion to Lift Stay" filed Nov. 23, 2016 (6 pages).

Case 2:16-cv-00781-RCJ-VCF, Document 69, "Order" filed Dec. 12, 2016 (11 pages).

Case 2:16-cv-00781-RCJ-VCF, Document 72, "DraftKings' Answer to Plaintiffs' First Amended Complaint and Affirmative Defenses" filed Dec. 27, 2016 (29 pages).

Defendants' Joint Invalidity Unenforceability And Invalidity Contentions, filed Mar. 21, 2017 (51 pages).

Kidnet, Kid's Guide to Surfing through Cyberspace by Brad and Debra Schepp—Nov. 1995 (9 pages).

The New York Times—Nintendo and Minnesota Set A Living-Room Lottery Test, Sep. 27, 1991, (4 pages).

The New York Times—Minnesota Cancels Plan to Play Lottery on Nintendo, Oct. 19, 1991 (3 pages).

AU First Examination Report for Application No. 2015200884; dated Mar. 6, 2017; 3 pages.

JP Office Action for Application No. 2016-147496; dated May 30, 2017; 4 pages (w/English Translations).

CA Examination Report for Application No. 2,906,638 dated Jan. 11, 2018; 6 pages.

CA Exam Report for Application No. 2906638 dated Nov. 23, 2018; 6 pages.

Case 2:16-cv-00871-RCJ-VCF, Document 63, "Order" filed Jan. 4, 2017 (10 pages).

Case 2:16-cv-00871-RCJ-VCF, Document 64, "Bwin's Answer to Plaintiffs' First Amended Complaint" filed Jan. 6, 2017 (15 pages).

Case 2:16-cv-00857-APG-VCF, Document 1, "Plaintiffs' Complaint for Patent Infringement" filed Apr. 14, 2016 (29 pages).

Case 2:16-cv-00857-RCJ-VCF, Document 27, "Defendant Big Fish Games, Inc.'s Motion to Dismiss", filed Jun. 17, 2016 (30 pages).

Case 2:16-cv-00857-RCJ-VCF, Document 32, "[Corrected] Defendant Big Fish Games, Inc.'s Motion to Dismiss", filed Jul. 8, 2016 (30 pages).

Case 2:16-cv-00857-RCJ-VCF, Document 33, "Plaintiffs' Opposition to Big Fish Games, Inc.'s Motion to Dismiss", filed Jul. 25, 2016 (32 pages).

Case 2:16-cv-00857-RCJ-VCF, Document 34, "Reply in Support of Defendant Big Fish Games, Inc.'s Motion to Dismiss", filed Aug. 4, 2016 (17 pages).

Case 2:16-cv-00857-RCJ-VCF, Document 36, "Order" filed Aug. 29, 2016 (29 pages).

Case 2:16-cv-00857-RCJ-VCF, Document 37, "Plaintiffs' First Amended Complaint for Patent Infringement", filed Sep. 28, 2016 (38 pages).

Case 2:16-cv-00857-RCJ-VCF, Document 39, "Defendant Big Fish Games, Inc.'s Motion to Dismiss Plaintiffs' First Amended Complaint", filed Oct. 12, 2016 (17 pages).

Case 2:16-cv-00857-RCJ-VCF, Document 45, "Plaintiffs' Opposition to Big Fish Games, Inc.'s Motion to Dismiss", filed Oct. 31, 2016 (22 pages).

Case 2:16-cv-00857-RCJ-VCF, Document 49, "Reply in Support of Defendant Big Fish Games, Inc.'s Motion to Dismiss", filed Nov. 10, 2016 (16 pages).

Case 2:16-cv-00857-RCJ-VCF, Document 59, "Order", filed Jan. 4, 2017 (9 pages).

Case 2:16-cv-00857-RCJ-VCF, Document 60, "Defendant Big Fish Games, Inc.'s Answer to First Amended Complaint", filed Jan. 19, 2017 (17 pages).

Case 2:16-cv-00858-MMD-GWF, Document 1, "Plaintiffs' Complaint for Patent Infringement" filed Apr. 14, 2016 (30 pages).

Case 2:16-cv-00858-RCJ-VCF, Document 19, "Defendant Double Down Interactive LLC's Motion to Dismiss", filed Jun. 7, 2016 (32 pages).

Case 2:16-cv-00858-RCJ-VCF, Document 30, "Plaintiffs' Opposition to Double Down's Motion to Dismiss", filed Jul. 8, 2016 (31 pages).

Case 2:16-cv-00858-RCJ-VCF, Document 51, "Reply in Support of Defendant Double Down Interactive LLC's Motion to Dismiss", filed Jul. 18, 2016 (14 pages).

Case 2:16-cv-00858-RCJ-VCF, Document 58, "Plaintiffs' First Amended Complaint for Patent Infringement", filed Sep. 28, 2016 (38 pages).

Case 2:16-cv-00858-RCJ-VCF, Document 63, "Defendant Double Down Interactive LLC's Motion to Dismiss Plaintiffs' First Amended Complaint for Patent Infringement", Oct. 17, 2016 (31 pages).

Case 2:16-cv-00858-RCJ-VCF, Document 69, "Plaintiffs' Opposition to Double Down Interactive, Inc.'s Motion to Dismiss", filed Nov. 3, 2016 (24 pages).

Case 2:16-cv-00858-RCJ-VCF, Document 76, "Defendant Double Down Interactive LLC's Reply in Support of Motion to Dismiss Plaintiffs' First Amended Complaint for Patent Infringement", filed Nov. 14, 2016 (18 pages).

Case 2:16-cv-00858-RCJ-VCF, Document 83, "Defendant Double Down Interactive LLC's Answer, Defenses, and Counterclaims to Plaintiffs' First Amended Complaint for Patent Infringement", filed Jan. 18, 2017 (19 pages).

Case 2:16-cv-00858-RCJ-VCF, Document 84, "Plaintiffs' Answer to Double Down Interactive LLC's Counterclaims Against CG Technology Development, LLC", filed Feb. 8, 2017 (4 pages).

Defendants' Joint Unenforceability and Invalidity Contentions dated Mar. 21, 2017 (51 pages).

IPR Decision for U.S. Pat. No. 9,306,952, Case IPR2017-01333, Nov. 13, 2017 (30 pages).

Patent Owner's Preliminary Response for U.S. Pat. No. 9,306,952, Case IPR2017-01333, Aug. 16, 2017 (49 pages).

Petition for Inter Partes Review of U.S. Pat. No. 9,306,952, Case IPR2017-01333, May 1, 2017 (74 pages).

IPR Decision for U.S. Pat. No. 9,355,518, Case IPR2017-01532, Dec. 13, 2017 (29 pages).

Patent Owner's Preliminary Response for U.S. Pat. No. 9,355,518, Case IPR2017-01532, Sep. 19, 2017 (27 pages).

Petition for Inter Partes Review of U.S. Pat. No. 9,355,518, Case IPR2017-01532, Jun. 8, 2017 (74 pages).

(56)

**References Cited**

## OTHER PUBLICATIONS

- ImagiNation—OnLine Games, 1995, 58 pages.
- ImagiNation, 1993 ImagiNation Network—A Quick Guide to Using Your Imagination, 16 pages.
- ImagiNation Network [R] General Documentation (INN), 27 pages.
- BYTE Magazine, Mar. 1984, vol. 9, No. 3 (552 pages).
- IBM Technical Reference, 1<sup>st</sup> Ed. Revised, Nov. 1983 (572 pages).
- IBM PC Jr. Advertising Booklet, 1983, 14 pages.
- IBM PC Jr. Order Form, Nov. 1983, 2 pages.
- Sierra 3-D Animated Adventure Game Reference Card for MS DOS, 1987 (4 pages).
- Leisure Suit Larry in the Land of the Lounge Lizards Manual, Jun. 4, 1987, 13 pages.
- Electronic Gaming Monthly, No. 89, Dec. 1996 (352 pages).
- Wireless Pro Fighter 8 Box Cover (1 page), Dec. 1996.
- Naki Wireless Pro Fighter 8 controller (1 page), Dec. 1996.
- Sega Saturn Instruction Manual (24 pages), May 11, 1995.
- Sega Saturn Overview Manual (67 pages), Jun. 27, 1995.
- Sega Saturn Overview Manual unlocked (67 pages), Jun. 27, 1995.
- Sega Saturn Introduction Manual (10 pages), Jun. 27, 1995.
- Game FAQs: Tokimeki Memorial: Forever With You, Dec. 13, 1996 (17 pages).
- How to get the most out of CompuServe, Charles Bowen and David Peyton, 1986 (58 pages).
- Alfred Glossbrenner's Master Guide to CompuServe, 1987 (25 pages).
- CompuServe Information Service Users Guide, Sep. 1986 (42 pages).
- The Official Guide to the Prodigy Service, John L. Vierscas, 1998 (77 pages).
- Wireless Gaming Makes Strides in Nevada by Libe Goad, PCMag.com, Jun. 9, 2005 (3 pages).
- Guinn gives OK to wireless gaming devices in casinos by Elizabeth White, Las Vegas Sun, Jun. 2, 2005 (8 pages).
- Welcome to Cantor Casino, Wayback machine, Oct. 2005 (1 page).
- Hand-held devices next wave in gaming, The Times, Aug. 12, 2005 (1 page).
- Rolling the dice, Casinos ready to put their money on wireless gaming devices, The Journal News, Nov. 14, 2005 (2 pages).
- Nevada Oks gambling on the go, The Courier Journal, Apr. 2, 2006 (1 page).
- Devices could bring mobile gaming to casinos, Reno Gazette-Journal, Mar. 24, 2006 (2 pages).
- Regulators approve wireless device by Ryan Randazzo, Reno Gazette Journal, Aug. 25, 2006.
- Nevada Gaming Commission Mobile Gaming Policies, May 18, 2006 (5 pages).
- Handheld gambling devices will show up soon in casinos by the Associated Press in the Florida Today Newspaper Aug. 3, 2005 (1 page).
- Cantor Fitzgerald Press Release—Cantor Fitzgerald Launches Cantor Casino and Cantor Gaming, Sep. 29, 2005 (2 pages).
- Coming to a Nevada casino soon: Playing the slots wirelessly, by the New York Times in the Arizona Republic Newspaper—Fox Butterfield, Jul. 4, 2005 (1 page).
- Minutes of the Meeting on the Assembly Committee on Judiciary, Seventy-Third Session, Apr. 8, 2005 (42 pages).
- O2 and Cantor Index bring gambling to PDAs by Jo Best of ZDNet, Sep. 3, 2003 (6 pages).
- Stocking fillers by Ashley Norton of the Guardian, Sep. 20, 2003 (5 pages).
- O2 XDA II Coming November by Fabrizio Pilato of Mobile Mag, Oct. 23, 2003 (6 pages).
- Securities and Exchange Commission—The XDA II from O2 Corners a Third of the Market in First Six Months Jul. 15, 2004 (3 pages).
- Final Notice to Cantor Index Limited from the Financial Services Authority, Dec. 30, 2004 (13 pages).
- Handheld devices can be used for games in Casino public areas by the Associated Press in NBC News, Mar. 24, 2006 (2 pages).
- Nevada approves new mobile gambling rules, GMA News Online, Mar. 24, 2006 (5 pages).
- Legalized Gambling as a Strategy for Economic Development by Robert Goodman Mar. 1994 (225 pages).
- New York Times—Two inventors contend that the V-chip is an idea they've seen before—in their own patent.—by Teresa Riordan Oct. 28, 1996 (4 pages).
- Wireless ATM & Ad-Hoc Networks by C-K Toh, Dec. 31, 1996 (23 pages).
- PC Mag—Wireless Gaming Makes Strides in Nevada, Jun. 9, 2005 (3 pages).
- The Times Money, Hand-held devices next wave in gaming, Aug. 12, 2005 (1 page).
- AOL—The Official America Online Tour Guide for Windows 3.1, 1996 Tom Lichty, Jul. 1996 (14 pages).
- Business Wire—Diamond I Opens Online Interactive Demo of its WifiCasino GS Gaming System, Apr. 27, 2005 (3 pages).
- Diamond I PRN Wire Diamond I Comments on Future of Hand-held Gambling Devices in Nevada, Jun. 2, 2005 (4 pages).
- Diamond I Rolls the Dice by Naomi Graychase, Feb. 23, 2005 (3 pages).
- Diamond I Opens Online Interactive Demo of its WifiCasino GS Gaming System, Business Wire, Apr. 27, 2005 (3 pages).
- Diamond I Responds to Inquiries: What is "WifiCasino GS"?, Business Wire, Jan. 27, 2005 (3 pages).
- Diamond I Technologies—Products, Wayback Machine, Apr. 29, 2005-Aug. 12, 2007, (2 pages).
- Diamond I Technologies—Products, Wayback Machine, Apr. 29, 2005-Jan. 6, 2010, (2 pages).
- Case 2:16-cv-00871-RCJ-VCF, Document 47, Motion to Dismiss Under Fed. R. Civ. P. 12(6)(6) filed Nov. 1, 2016 (7 pages).
- Case 2:16-cv-00871-RCJ-VCF, Document 55, Reply in Support of Defendants' Motion to Dismiss Under Fed. R. Civ. P. 12(6)(6), filed Nov. 30, 2016 (6 pages).

\* cited by examiner

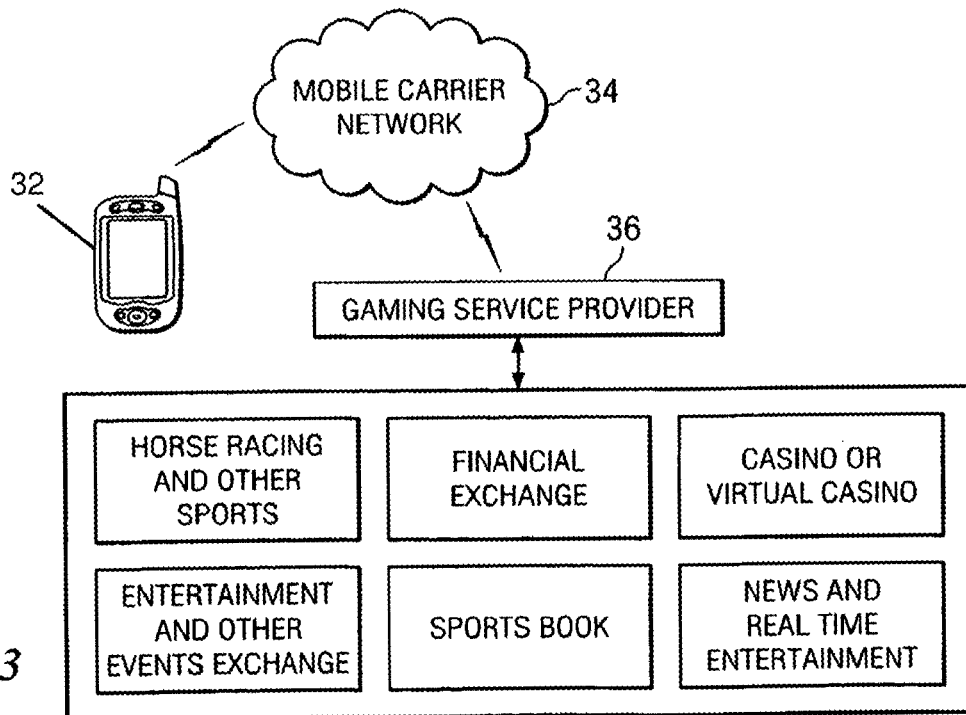
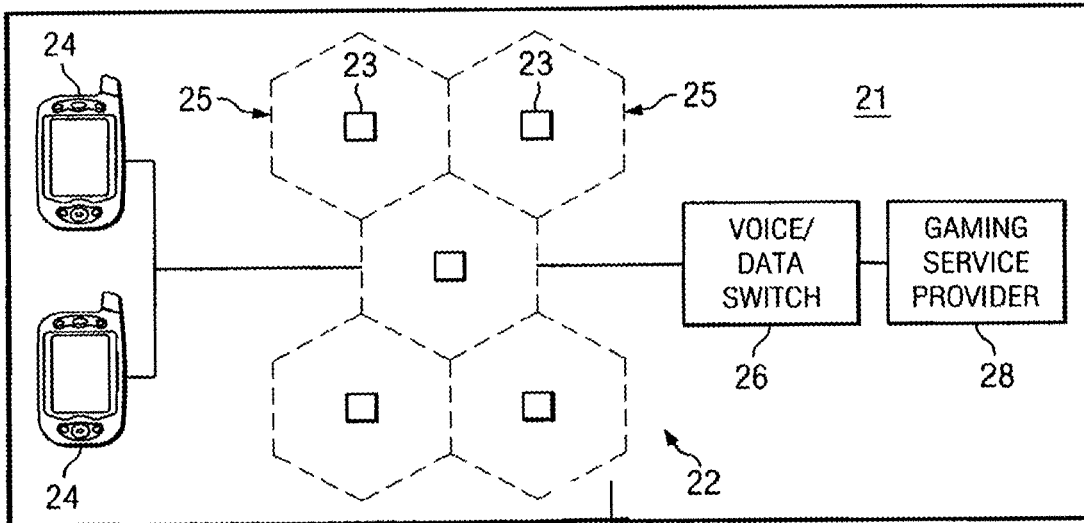
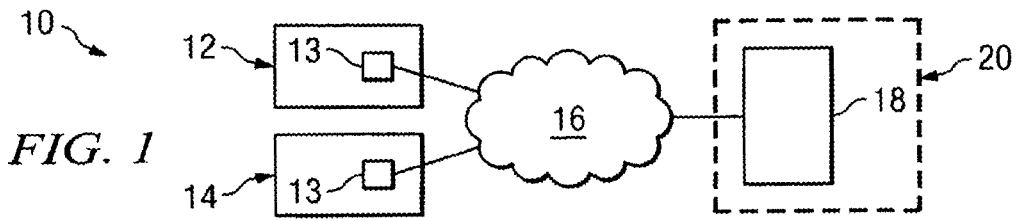

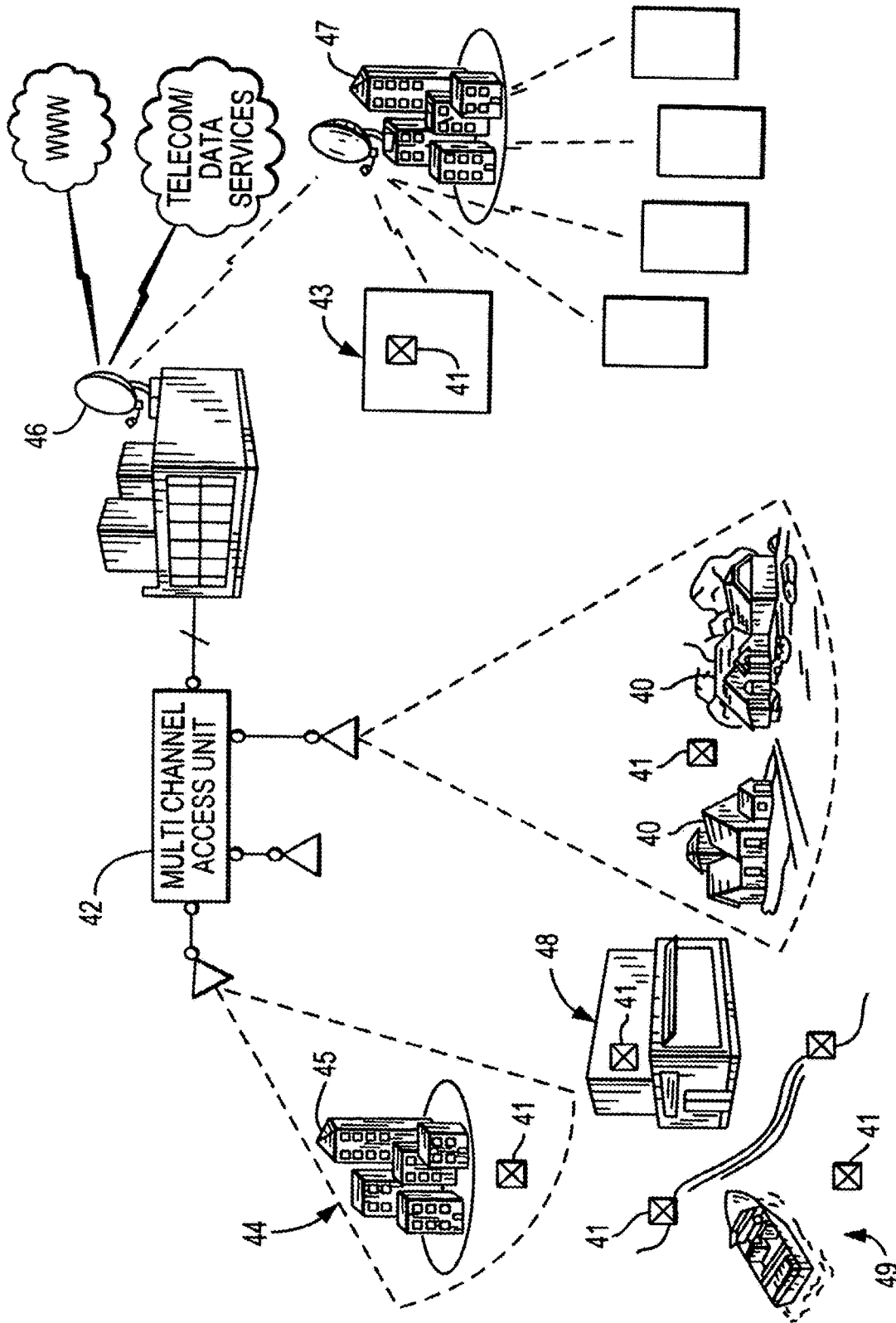

FIG. 4

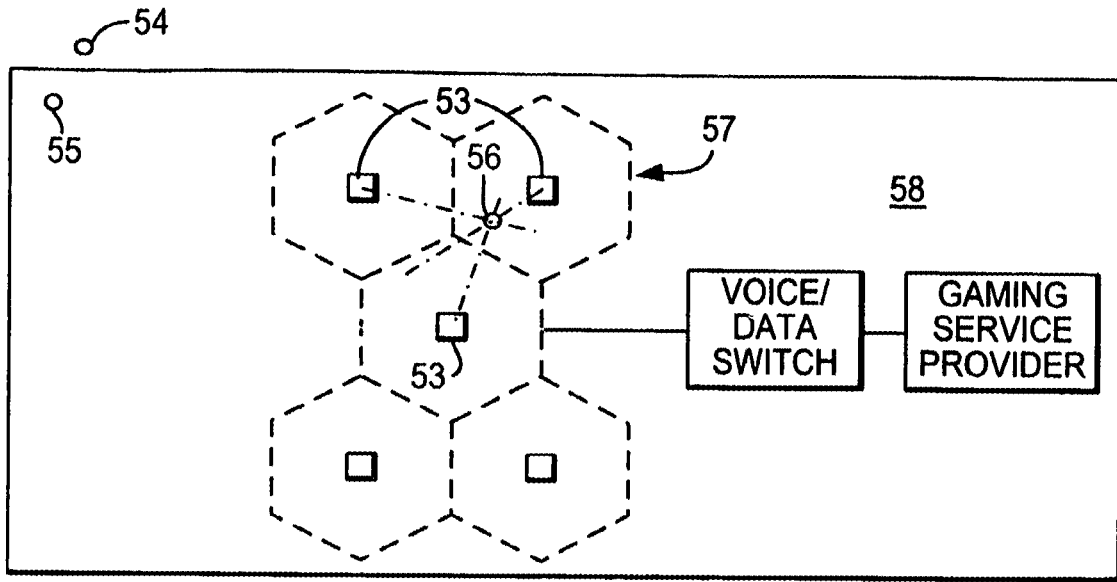

FIG. 5

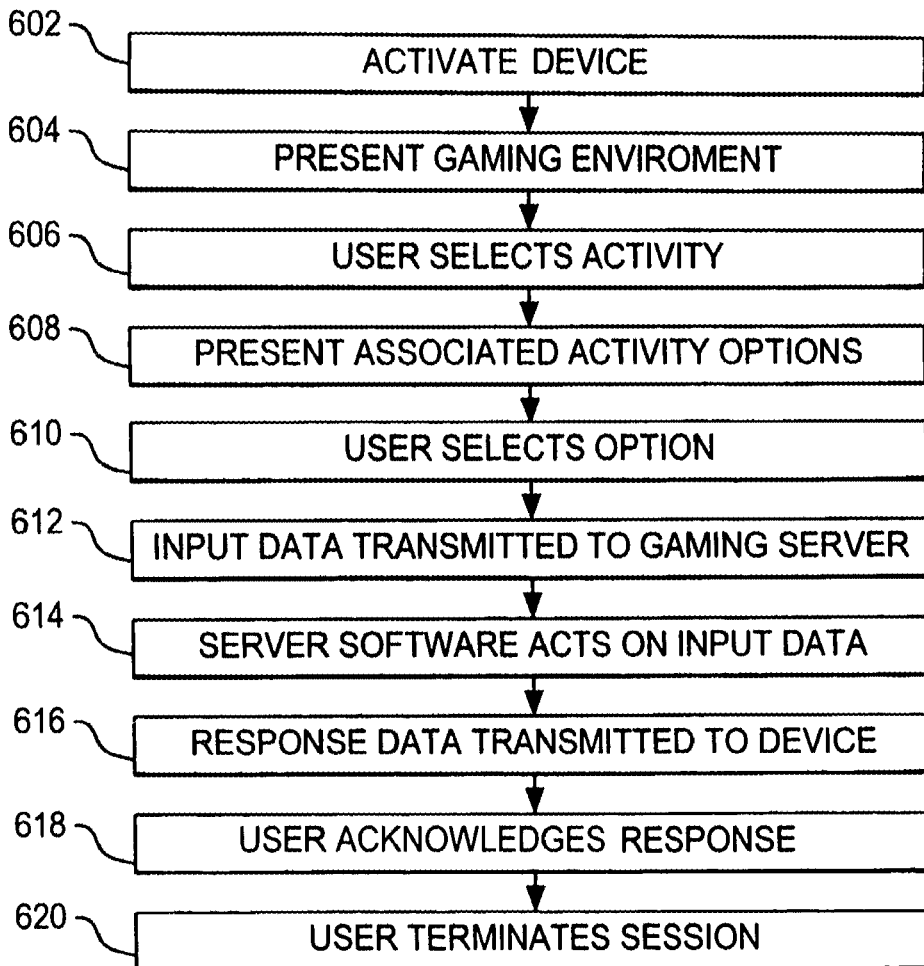

FIG. 6



FIG. 7

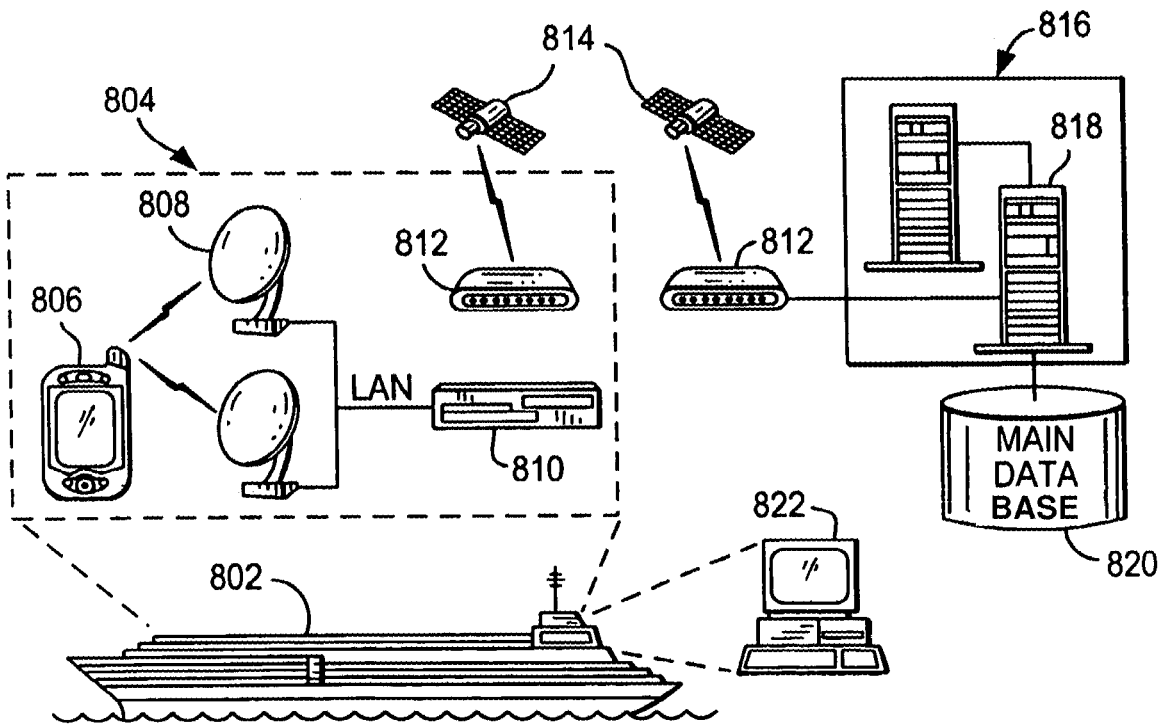
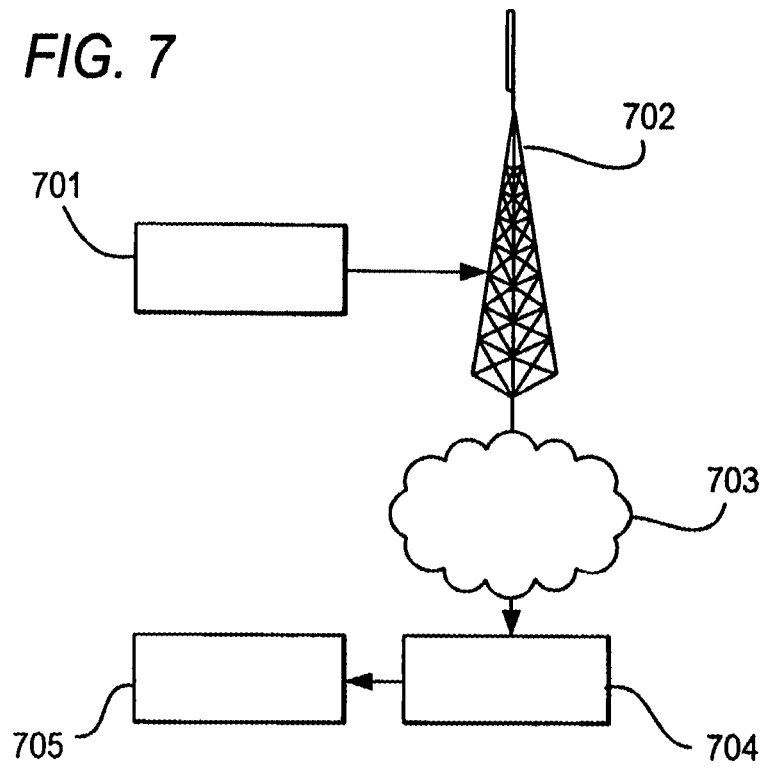
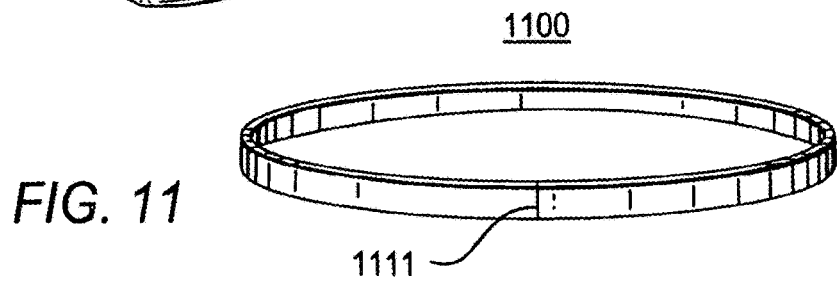
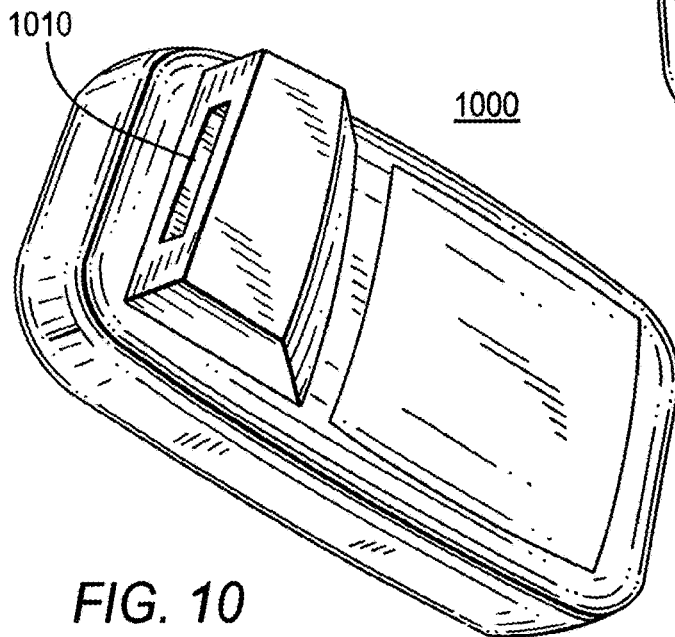
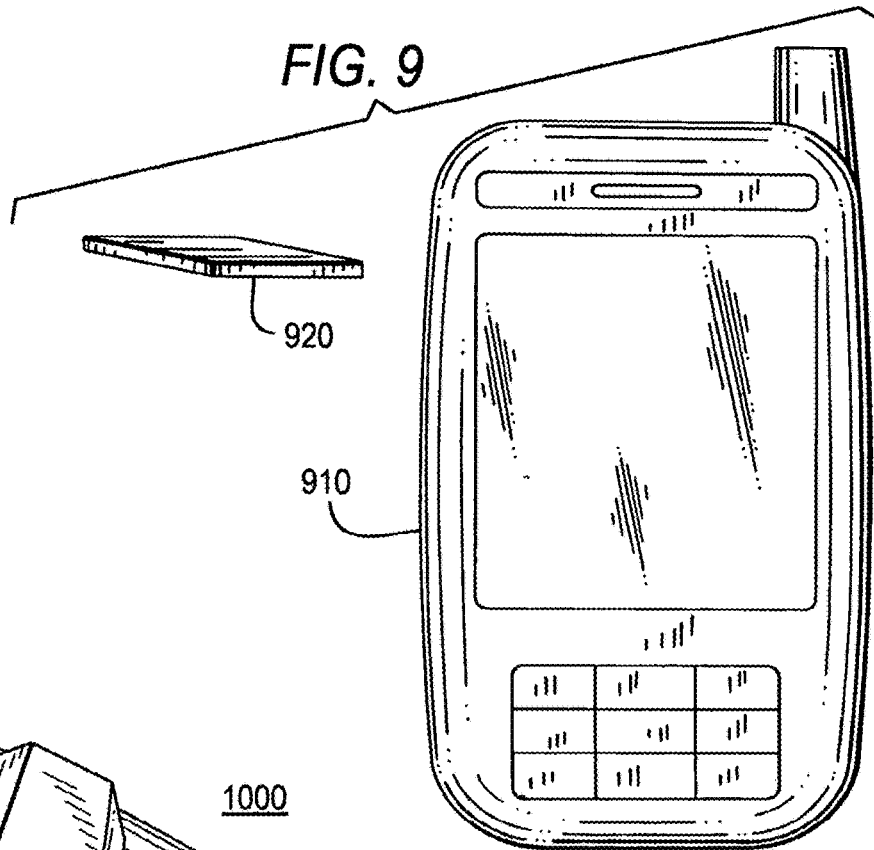

FIG. 8



## SYSTEMS AND METHODS FOR PROVIDING ACCESS TO LOCATIONS AND SERVICES

### CROSS REFERENCE TO RELATED APPLICATION

This application is a continuation of U.S. patent application Ser. No. 14/252,407, filed Apr. 14, 2014, which is a continuation of U.S. patent application Ser. No. 12/324,269, filed Nov. 26, 2008 (now U.S. Pat. No. 8,695,876), which is a continuation of U.S. patent application Ser. No. 11/418,939, filed May 5, 2006 (now U.S. Pat. No. 7,549,576), each of which is hereby incorporated by reference herein in its entirety.

### FIELD OF THE INVENTION

The present invention relates generally to the field of gaming and, more particularly, to a gaming system and method incorporating a wireless network and systems and methods for providing access thereto.

### BACKGROUND OF THE INVENTION

Virtual casinos are accessible via communications networks such as the Internet. For example, on-line casinos present a graphical representation of games, such as casino games, to a user on the screen of a computer in communication with the Internet. The user may place wagers, participate in the gaming, and win or lose money. Receipt of winnings, or payment of losses is typically handled through a credit account.

Participants may use gaming devices, some of which may be wireless, to access such on-line casinos. However, security of wireless gaming devices (e.g., handhelds such as the Blackberry™ handheld device) may be sub-optimal as it is typically accomplished through soft checks. For example, a user may be merely asked to enter a valid user name and associated password to provided access to a particular gaming device.

It would therefore be desirable to provide mechanisms that better guarantee secure access to wireless gaming devices and gaming systems.

### SUMMARY OF THE INVENTION

Therefore, it is an object of the invention to provide mechanisms that better guarantee secure access to wireless gaming devices and gaming systems.

This and other objects are accomplished in accordance with the principles of the invention by providing gaming networks with one or more levels of security checks, such as a hard security check, instead of, or in addition to, a soft security check before access to a gaming device is granted. In a hard security check, the user employs an apparatus such as a card or other physical token that can be used to access the gaming device. Such an apparatus may communicate information that identifies the user to the device or may be used to produce a signal without which the device is locked.

In some embodiments of the present invention, a device capable of detecting or reproducing a signal from an apparatus is provided. Access to the device is provided when the signal is detected. Alternatively or additionally, the signal may include identifying information that needs to be verified in order to provide access to the device. The apparatus may include a medium for storing identifying information as well as an emitter for communicating the identifying information

to the device such that access to the device is provided when the identifying information is associated with a user that is authorized to operate the device.

### BRIEF DESCRIPTION OF THE DRAWINGS

For a more complete understanding of the present invention and for further features and advantages, reference is now made to the following description, taken in conjunction with the accompanying drawings, in which:

FIG. 1 illustrates a convenience gaming system according to certain embodiments of the present invention;

FIG. 2 illustrates a convenience gaming system with a wireless network according to certain embodiments of the present invention;

FIG. 3 is a block diagram of a convenience gaming system illustrating various gaming activities in accordance with certain embodiments of the present invention;

FIG. 4 illustrates a convenience gaming system showing coverage areas in accordance with certain embodiments of the present invention;

FIG. 5 illustrates a convenience gaming system with a wireless network showing triangulation location determination in accordance with certain embodiments of the present invention;

FIG. 6 is a flow chart depicting steps in a convenience gaming method according to certain embodiments of the present invention;

FIG. 7 depicts a convenience gaming system showing a communication path in accordance with certain embodiments of the present invention;

FIG. 8 illustrates a ship-based convenience gaming system in accordance with certain embodiments of the present invention;

FIG. 9 illustrates a convenience gaming device and apparatus for use in accordance with certain embodiments of the present invention;

FIG. 10 illustrates a convenience gaming device and apparatus in accordance with certain embodiments of the present invention; and

FIG. 11 illustrates another convenience gaming device in accordance with certain embodiments of the present invention.

### DETAILED DESCRIPTION OF THE INVENTION

A convenience gaming system enables participants to engage in gaming activities from remote and/or mobile locations. The possible gaming activities include gambling, such as that provided by casinos. Gambling activities may include any casino-type gambling activities including, but not limited to, slot machines, video poker, table games (e.g., craps, roulette, blackjack, pai gow poker, Caribbean stud poker, baccarat, etc), the wheel of fortune game, keno, sports betting, horse racing, dog racing, jai alai, and other gambling activities. The gaming activities can also include wagering on any type of event. Events can include, for example, sporting events, such as horse or auto racing, and athletic competitions such as football, basketball, baseball, golf, etc. Events can also include such things that do not normally involve wagering. Such events may include, without limitation, political elections, entertainment industry awards, and box office performance of movies. Gaming can also include non-wagering games and events. Gaming can also include lotteries or lottery-type activities such as state and interstate lotteries. These can include all forms of number-

selection lotteries, “scratch-off” lotteries, and other lottery contests. The convenience gaming system may be implemented over a communications network such as a cellular network or a private wireless and/or wireline network. Examples of the latter include WiFi and WiMax networks. In some embodiments, the convenience gaming system communications network is entirely independent of the Internet. In other embodiments, the convenience gaming system operation makes minimal use of the Internet, such that only information for which there is no security issues is transmitted via the Internet and/or information may be encrypted. Preferably, the communications network enables players to participate in gaming from remote locations (e.g., outside of the gaming area of a casino). Also, the system may enable players to be mobile during participation in the convenience gaming activities. Preferably, the system has a location verification or determination feature, which is operable to permit or disallow gaming from the remote location depending upon whether or not the location meets one or more criteria. The criterion may be, for example, whether the location is within a pre-defined area in which gaming is permitted by law.

As shown in FIG. 1, for example, convenience gaming system 10 includes at least one user 12. The system may include additional users such that there is at least a first user 12 and a second user 14. Multiple users may access a first convenience gaming system 10, while other multiple users access a second convenience gaming system (not shown) in communication with first gaming system 10. Users 12 and 14 preferably access system 10 by way of a gaming communication device 13. Gaming communication device 13 may comprise any suitable device for transmitting and receiving electronic communications. Examples of such devices include, without limitation, mobile phones, PDAs, computers, mini-computers, etc. Gaming communication devices 13 transmit and receive gaming information to and from communications network 16. Gaming information is also transmitted between network 16 and a computer 18, such as a server, which may reside within the domain of a gaming service provider 20. The location of computer 18 is not critical, however, and computer 18 may reside adjacent to or remote from the domain of gaming service provider 20. Moreover, in certain embodiments, a gaming service provider is not required. The computer 18 and/or gaming service provider 20 may reside within, adjacent to, or remote from a gaming provider (not shown in FIG. 1). The gaming provider may be an actual controller of games, such as a casino. As an example, a gaming service provider may be located on the grounds of a casino and the computer 18 may be physically within the geographic boundaries of the gaming service provider. As discussed, however, either possibilities exist for remote location of the computer 18 and the gaming service provider 20. Computer 18 may function as a gaming server. Additional computers (not expressly shown) may function as database management computers and redundant servers, for example.

Preferably, software resides on both the gaming communication device 13 and the computer 18. Software resident on gaming communication device 13 is preferably operable to present information corresponding to gaming activities (including gambling and non-gambling activities discussed herein) to the user. The information includes, without limitation, graphical representations of objects associated with the activities, and presentation of options related to the activities and selectable by the user. The gaming communication device software is also preferably operable to receive data from the computer and data input by the user or

information communicated through another device or apparatus. Software resident on the computer is preferably able to exchange data with the gaming communication device, access additional computers and data storage devices, and perform all of the functions described herein as well as functions common to known electronic gaming systems.

Gaming information transmitted across network 16 may include any information, in any format, which is necessary or desirable in the operation of the gaming experience in which the user participates. The information may be transmitted in whole, or in combination, in any format including digital or analog, text or voice, and according to any known or future transport technologies, which may include, for example, wireline or wireless technologies. Wireless technologies may include, for example, licensed or license-exempt technologies. Some specific technologies which may be used include, without limitation, Code Division Multiple Access (CDMA), Global System for Mobile Communication (GSM), General Packet Radio Service (GPRS), WiFi (802.11x), WiMax (802.16x), Public Switched Telephone Network (PSTN), Digital Subscriber Line (DSL), Integrated Services Digital Network (ISDN), or cable modem technologies. These are examples only and one of ordinary skill will understand that other types of communication techniques are within the scope of the present invention. Further, it will be understood that additional components may be used in the communication of information between the users and the gaming server. Such additional components may include, without limitation, lines, trunks, antennas, switches, cables, transmitters, receivers, computers, routers, servers, fiber optical transmission equipment, repeaters, amplifiers, etc.

In at least one embodiment, the communication of gaming information may take place through the Internet or without involvement of the Internet. In certain embodiments, a portion of the gaming information may be transmitted over the Internet. Also, some or all of the gaming information may be transmitted partially over an Internet communications path. In certain embodiments, some information is transmitted entirely or partially over the Internet, but the information is either not gaming information or is gaming information that does or does not need to be maintained secretly. For instance, data that causes a graphical representation of a table game on the user’s gaming communication device might be transmitted at least partially over the Internet, while wagering information transmitted by the user might be transmitted entirely over a non-Internet communications network. As another example, identifying information associated with a hard check apparatus (e.g., a bracelet as discussed below) may or may not be transmitted from the gaming communication device to a server over the Internet.

According to some embodiments of the invention, as shown in FIG. 2 for example, the communications network 21 comprises a cellular network 22. Cellular network 22 comprises a plurality of base stations 23, each of which has a corresponding coverage area 25. Base station technology is generally known and the base stations may be of any type found in a typical cellular network. The base stations may have coverage areas that overlap. Further, the coverage areas may be sectorized or non-sectorized. The network also includes mobile stations 24, which function as the gaming communication devices used by users to access the convenience gaming system and participate in the activities available on the convenience gaming system. Users are connected to the network of base stations via transmission and reception of radio signals. The communications network

also includes at least one voice/data switch **26**, which is preferably connected to the wireless portion of the network via a dedicated, secure landline. The communications network also includes a gaming service provider **28**, which is likewise connected to the voice/data switch via a dedicated, secure landline. The voice/data switch may be connected to the wireless network of base stations via a mobile switching center (MSC), for example and the landline may be provided between the voice/data switch and the MSC.

Users access the convenience gaming system by way of mobile stations which are in communication with, and thus part of, the communications network. The mobile station may be any electronic communication device that is operable in connection with the network as described. For example, in this particular embodiment, the mobile station may comprise a cellular telephone.

Preferably, in the case of a cellular network for example, the convenience gaming system is enabled through the use of a private label carrier network. Each base station is programmed by the cellular carrier to send and receive private secure voice and/or data transmissions to and from mobile station handsets. The handsets are preferably pre-programmed with both gaming software and the carrier's authentication software. The base stations communicate via Private T-1 lines to a switch. A gaming service provider leases a private T-1 or T-3 line, which routes the calls back to gaming servers controlled by the gaming service provider. Encryption can be installed on the telephones if required by a gaming regulation authority, such as a gaming commission.

The cellular network is preferably a private, closed system. Mobile stations communicate with base stations and base stations are connected to a centralized switch located within a gaming jurisdiction. At the switch, voice calls are transported either locally or via long distance. Specific service provider gaming traffic is transported from the central switch to a gaming server at a host location, which can be a casino or other location.

As subscribers launch their specific gaming application, the handset will only talk to certain base stations with cells or sectors that have been engineered to be wholly within the gaming jurisdiction. For example, if a base station is close enough to pick up or send a signal across state lines, it will not be able to communicate with the device. When a customer uses the device for gaming, the system may prohibit, if desired, the making or receiving voice calls. Moreover, voice can be eliminated entirely if required. Further, the devices are preferably not allowed to "connect" to the Internet. This ensures a high level of certainty that bets/wagers originate and terminate within the boundaries of the gaming jurisdiction and the "private" wireless system cannot be circumvented or bypassed. In certain embodiments, some data and/or voice traffic may be communicated at least partially over the Internet. In some embodiments, certain non-gaming information may be transported over a path which includes the Internet, while other information relating to the gaming activities of the system is transported on a path that does not include the Internet.

As shown in FIG. 3, a gaming communication device **32** is in communication with a gaming service provider **36** over a network **34**. The gaming service provider preferably has one or more servers, on which are resident various gaming and other applications. As shown in FIG. 3, some example gaming applications include horse racing and other sports, financial exchange, casino and/or virtual casino, entertainment and other events exchange, and news and real time entertainment. Each of these applications may be embodied

in one or more software modules. The applications may be combined in any possible combination. Additionally, it should be understood that these applications are not exhaustive and that other applications may exist to provide an environment to the user that is associated with any of the described or potential convenience activities.

In other embodiments of the invention, as shown in FIG. 4, for example, the communications network comprises a private wireless network. The private wireless network may include, for example, an 802.11x (WiFi) network technology to cover "Game Spots" or "Entertainment Spots." In FIG. 4, various WiFi networks are indicated as networks **41**. Networks **41** may use other communications protocols to provide a private wireless network including, but not limited to, 802.16x (WiMax) technology. Further, networks **41** may be interconnected. Also, a convenience gaming system may comprise a combination of networks as depicted in FIG. 4. For example, there is shown a combination of private wireless networks **44**, a cellular network comprising a multi-channel access unit or sectorized base station **42**, and a satellite network comprising one or more satellites **46**.

With respect to the private wireless network, because the preferable technology covers smaller areas, (e.g., in the range of 100-300 feet) and provides very high-speed throughput, the private wireless network is particularly well-suited for gaming commission needs of location and identity verification for the gaming service provider products. The gaming spots enabled by networks **41** may include a current casino area **48**, new areas such as swimming pools, lakes or other recreational areas **49**, guest rooms and restaurants such as might be found in casino **48** or hotels **45** and **47**, residential areas **40**, and other remote convenience gaming areas **43**. The configuration of the overall convenience gaming system depicted in FIG. 4 is intended only as an example and may be modified within the scope of the invention.

In some embodiments of the invention, the system architecture for the convenience gaming system includes:

(1) a wireless LAN (Local Access Network) component, which consists of mostly 802.11x (WiFi) and/or 802.16x WiMax technologies; robust security and authentication software; gaming software; mobile carrier approved handsets with Windows® or Symbian® operating systems integrated within; and

(a) CDMA-technology that is secure for over-the-air data protection;

(b) at least two layers of user authentication, (that provided by the mobile carrier and that provided by the gaming service provider);

(c) compulsory tunneling (static routing) to gaming services;

(d) end-to-end encryption at the application layer; and

(e) state-of-the-art firewall and DMZ technologies;

(2) an MWAN (Metropolitan Wireless Access Network), which consists of licensed and license-exempt, point-to-point links, as well as licensed and license-exempt, point-to-multi-point technologies;

(3) private MAN (Metropolitan Access Network) T-1 and T-3 lines to provide connectivity where wireless services cannot reach; and

(4) redundant private-line communications from the mobile switch back to the gaming server.

Each of the "Game Spots" or "Entertainment Spots" are preferably connected via the MWAN/MAN back to central and redundant game servers. For accessing the private wireless networks **41**, the gaming communication devices

are preferably WiFi- or WiMax-enabled PDAs or mini-laptops, and do not have to be managed by a third-party partner.

Preferably, the convenience gaming system includes a location verification feature, which is operable to permit or disable gaming from a remote location depending upon whether or not the location meets one or more criteria. The criterion may be, for example, whether the location is within a pre-defined area in which gaming is permitted by law. As another example, the criterion may be whether the location is in a no-gaming zone, such as a school. The location verification technology used in the system may include, without limitation, "network-based" and/or "satellite-based" technology. Network-based technology may include such technologies as multilateration, triangulation and geo-fencing, for example. Satellite-based technologies may include global positioning satellite (GPS) technology, for example.

As previously discussed, the cellular approach preferably includes the use of at least one cellular, mobile, voice and data network. For gaming in certain jurisdictions, such as Nevada for example, the technology may involve triangulation, global positioning satellite (GPS) technology, and/or geo-fencing to avoid the potential for bets or wagers to be made outside Nevada state lines. In some embodiments, the network would not cover all of a particular jurisdiction, such as Nevada. For instance, the network would not cover areas in which cellular coverage for a particular base station straddled the state line or other boundary of the jurisdiction. This is done in order to permit the use of location verification to insure against the chance of bets originating or terminating outside of the state. Triangulation may be used as a method for preventing gaming from unapproved locations. Triangulation may be accomplished, for example, by comparing the signal strength from a single mobile station received at multiple base stations, each having GPS coordinates. This technology may be used to pinpoint the location of a mobile station. The location can then be compared to a map or other resource to determine whether the user of the mobile station is in an unapproved area, such as a school. Alternatively, GPS technology may be used for these purposes.

As shown in FIG. 5, the convenience gaming system includes a plurality of gaming communication devices 54, 55, and 56. Device 54 is located outside the gaming jurisdiction 58. Devices 55 and 56 are both located inside gaming jurisdiction 58. However only device 56 is located within geo-fence 57, which is established by the coverage areas of a plurality of base station 53. Thus, geo-fencing may be used to enable gaming via device 56 but disable gaming via devices 54 and 55. Even though some gaming communication devices that are within the gaming jurisdiction 58, such as device 55, are not permitted access to the convenience gaming system, the geo-fence 57 ensures that no gaming communication devices outside jurisdiction 58, such as device 54, are permitted access.

Geo-fencing does not specify location. Rather, it ensures that a mobile station is within certain boundaries. For instance, geo-fencing may be used to ensure that a mobile station beyond state lines does not access the convenience gaming system. Triangulation on the other hand specifies a pinpoint, or near-pinpoint, location. For example, as shown in FIG. 5, device 56 is triangulated between three of the base stations 53 to determine the location of device 56. Triangulation may be used to identify whether a device, such as a mobile station, is located in a specific spot where gambling is unauthorized (such as, for example, a school). Preferably, the location determination technology utilized in conjunc-

tion with the invention meets the Federal Communication Commission's (FCC's) Phase 2 E911 requirements. Geological Institute Survey (GIS) mapping may also be utilized to compare identified coordinates of a gaming communication device with GIS map features or elements to determine whether a device is in an area not authorized for gaming. It should be noted that any type of location verification may be used such as triangulation, geo-fencing, global positioning satellite (GPS) technology, or any other type of location determining technology, which can be used to ensure, or provide an acceptable level of confidence, that the user is within an approved gaming area.

In other embodiments, location verification is accomplished using channel address checking or location verification using some other identifying number or piece of information indicative of which network or portion of a network is being accessed by the gaming communication device. Assuming the using of an identifying number for this purpose, then according to one method of location checking, as an example, a participant accesses the gaming system via a mobile telephone. The identifying number of the mobile telephone, or of the network component being accessed by the mobile telephone, identifies the caller's connection to the mobile network. The number is indicative of the fact that the caller is in a defined area and is on a certain mobile network. A server application may be resident on the mobile telephone to communicate this information via the network to the gaming service provider. In related embodiments, the identifying number for information is passed from a first network provider to a second network provider. For example, a caller's home network may be that provided by the second provider, but the caller is roaming on a network (and in a jurisdiction) provided by the first provider. The first provider passes the identifying information through to the second provider to enable the second provider to determine whether the caller is in a defined area that does or does not allow the relevant gaming activity. Preferably the gaming service provider either maintains, or has access to, a database that maps the various possible worldwide mobile network identifying numbers to geographic areas. The invention contemplates using any number or proxy that indicates a network portion of a network, or network component, which is being connected with a mobile telephone. The identifying number may indicate one or more of a base station or group of base stations, a line, a channel, a trunk, a switch, a router, a repeater, etc.

In other embodiments of the present invention, when the user connects his telephone to the gaming server, the gaming server draws the network identifying information and communicates that information into the gaming service provider. The software resident on the gaming communication device may incorporate functionality that will, upon login or access by the user, determine the user's location (based at least in part on the identifying information) and send a message to the gaming service provider. The identifying number or information used to determine location may be country-specific, state-specific, town-specific, or specific to some other definable boundaries.

In connection with any of the location determination methods, the gaming system may periodically update the location determination information. This may be done, for example, during a gaming session, at pre-defined time intervals to ensure that movement of the gaming communication device to an unauthorized area is detected during play, and not just upon login or initial access.

Thus, depending on the location determination technology being used, the decision whether to permit or prohibit a

gaming activity may be made at the gaming communication device, at the gaming server, or at any of the components of the telecommunication network being used to transmit information between the gaming communication device and the gaming server (such as at a base station, for example).

An aspect of the private wireless network related to preventing gaming in unauthorized areas is the placement of sensors, such as Radio Frequency Identification (RFID) sensors on the gaming communication devices. The sensors trigger alarms if users take the devices outside the approved gaming areas. Further, the devices may be “tethered” to immovable objects. Users might simply log in to such devices using their ID and password.

In connection with FIG. 6, an example embodiment of a method according to the invention can be described as follows. As discussed, software is preferably loaded on a gaming communication device and is operable to receive input data for gaming. The input data may originate at associated gaming software resident on the gaming server, or it may be input by the user of the gaming communication device. The software on the device is operable to present a representation of a gaming environment. This can include, among other things, a representation of a table game such as a blackjack table or a slot machine. Other examples of the representation of a gaming environment include graphical representations of any of the other applications described herein.

In the example method shown in FIG. 6, in a first step 602, the gaming communication device is activated. This may take place as a function of turning on a phone, PDA, or other communication device as described elsewhere herein. Preferably, activation comprises connecting the gaming communication device to a private data network. Part of the activation includes logging in at a prompt. This may be considered as a first level of authentication of a user of the gaming communication device. A second level of user authentication comprises authentication of the gaming communication device itself. This may occur, for example, by authentication of a mobile station by a mobile carrier. A third level of user identification may comprise biometrics. Various examples of biometrics may include, but are not limited to, fingerprint identification, photo identification, retina scanning, voice print matching, etc.

In a next step 604, the user is presented with the gaming environment. The gaming environment may be presented in various stages. For instance, in a first stage, the gaming environment may comprise a casino lobby where the user is presented with certain gaming options including, for example, table games, slots, sports book, video poker, and a casino cashier. In a subsequent stage, the user may be presented with optional instances of the type of activity selected from the casino lobby.

In a next step 606, the user selects an activity, such as a particular casino table game. In step 608, the user is presented with one or more options related to the selected activity. In step 610, the user selects an option. For instance, at this point, the user might place a wager, draw a card, select a restaurant or restaurant menu item, select a news source or a news story, place a buy or sell order on a financial exchange, place a bet on a certain box office performance over/under amount for a given movie, etc. The options for user input are myriad. In step 612, the software resident on the gaming communication device accepts the option input by the user and transmits the input data to the software resident at the gaming server. In step 614, the gaming server software acts on the input data.

Actions in this point, may include, without limitation, determining an outcome and/or amount, accessing another server and/or software application, retrieving information, preparing a response to the user, etc. The action of determining an outcome and/or amount might take place, for example, if the user is using the device to place wagers in connection with a gambling activity. For certain gambling activities, such as a table game or slot machine, a random number generator may be incorporated to determine the outcome (i.e., whether the user won or lost) and the gaming server software would also determine an amount won or lost based on the amount wagered and any applicable odds. The action of accessing another server and/or software application might occur, for example, in the event the user is engaging in a services activity such as accessing news services, making reservations and placing food and beverage orders at a restaurant, or making a retail purchase. The action of retrieving information might occur when the gaming server software is prompted to access another server for the purpose of retrieving a certain type of information requested by the user.

Preferably, the gaming server software prepares a response to the user’s input data and in step 616. In step 618, the user acknowledges the response. For example, in the case of gambling, the user might acknowledge that he won a hand of blackjack because the dealer busted and that his payout was \$100 based on a \$50 bet at even odds. In step 620, the user logs out.

In the situation where the user is gambling, after the series of steps described in connection with FIG. 6, (or a subset or modified series of steps), the user physically enters a casino and goes to a casino cashier for payout and/or settlement (which can include, for example, extensions of credit or advance deposits). In some embodiments, there is a waiting period (e.g., twenty-four hours) before the user can collect winnings. The purpose of the waiting period is to allow time for fraud monitoring. The waiting period may depend on the amount of the balance. For example, if the user is owed less than \$5,000 the waiting period may be twelve hours. If the user is owed between \$5,000 and \$10,000 the waiting period may be twenty-four hours. If the user is owed more than \$10,000 the waiting period may be forty-eight hours.

Preferably, data is transmitted back and forth during the convenience gaming activities between the gaming communication device and a server controlled by the gaming service provider. An example of the path of communication is shown in FIG. 7. Gaming data, such as a wager placed by the user, is transmitted from gaming communication device 701 to a base station 702 (or a transmitter in the case of a private wireless network such as a WiFi or WiMax network). Base station 702 routes the data through network 703 to a hub or gateway 704, which in turn routes the data to a gaming server 705 operated by a gaming service provider. Preferably, the communication from gaming communication device 701 to the network 703 comprises wireless communication. This may be any type of known wireless communication, or any type of wireless communication available in the future. Examples of acceptable wireless communication protocols include CDMA, GSM, and GPRS.

Preferably, the communication from the network 703 to the gateway 704 and to the server 705 are conducted over secure land line. FIG. 7 is an example communication network only and the invention should be understood to cover other networks in which data may be transmitted from gaming communication device 701 to server 705. Preferably, data in response to data being transmitted from gaming communication device 701 to server 705 is transmitted back

to gaming communication device **701** along a path essentially opposite to the path of the first transmission. It should be noted that in at least certain embodiments of the methods and systems described herein, a user is not actually playing a game on the gaming communication device. Rather, the user is actually playing the game on the server controlled by the gaming service provider, which may be located within a casino, thereby interacting with the gaming device and the server. In other embodiments, the user may be playing the game on the gaming device itself or interacting solely with the device.

With respect to payment and/or receipt of winnings and losses, one possible approach is as follows. Upon check-in at a casino hotel, a hotel representative may query a guest as to whether the guest wants access to a convenience gaming device. If the guest does want such access, the hotel representative may provide the guest with a gaming communication device in exchange for a credit-card type deposit or other deposit. The guest then deposits money into an account for wireless gaming. The guest's account balance information is loaded onto the guest's account file, which is preferably maintained on the gaming server. The user may load money into his gaming account by establishing a credit account, for example, at a casino cashier and/or by paying cash to the casino cashier. Many other alternatives exist and this process is an example only. Guest accounts or gaming communication devices may be preloaded with funds. Funds may be deposited during a convenience gaming session. This may occur, for example, if a user selected a casino cashier activity from the gaming environment and instructed the cashier to add funds to the account. The finance subsystem may also utilize account card technology (such as ATM cards, credit cards, stored value cards, gift cards, etc) in order to conduct financial transactions associated with a user's account. Moreover, the user may receive or make payments remotely, by way of inputting instructions via the gaming communication device or by another remote device such as an automatic teller machine (ATM), which is in electronic communication with the gaming server or other server operated by the casino, hotel, gaming service provider or other entity involved in the convenience gaming activities. For example, a user might remotely (via the gaming communication device) place an order at a restaurant. Then, the user might make advance payment for the meal at an ATM-type machine which is operable to receive instructions corresponding to the financial transaction requirements of the convenience gaming activity of ordering food.

Electronic records of the gaming transactions undertaken by a user may be established. Preferably, this is accomplished by utilization of a keystroke log, which is an electronic record of all keystrokes made by the user. Utilization of a keystroke log in this context allows for unprecedented monitoring of a user's gaming activity. In the event of a dispute, one may refer to the keystroke log and readily determine whether, in fact, a user placed a particular wager, for example.

An additional possible aspect of the electronic record is to allow a gaming control board or other regulatory authority, access to the electronic record in a direct manner in order to conduct periodic independent monitoring of the convenience gaming activities conducted over the system. Another possible aspect is to allow policing against rigged machines. For instance, it is possible that the gaming control board (or other regulatory authority) could obtain a gaming communication device and compare their test results over time against records in the electronic record database (e.g., by

comparing the results shown in the keystroke log). This essentially comprises electronic access for testing.

In other embodiments of the invention, as shown in FIG. **8**, a ship-based convenience gaming system is provided. The system preferably comprises passenger vessel **802**, such as a cruise liner for example. The system includes one or more gaming communication devices **806** connected to a communication network. The network shown in FIG. **8** comprises a mobile network with base stations **808** connected via a LAN to a base station controller (BSC) **810**. BSC **810** is connected via a T1 interface to a first Very Small Aperture Terminal (SAT) modem **812**, which is in communication with a first satellite **814**. First satellite **814** is operable to transmit and receive signals from second satellite **814**, which is in communication with second VSAT modem **812**. Second VSAT modem **812** is in communication with a gaming server **818** located at gaming service provider **816**. Gaming server is coupled to gaming database **820**. Again, the network configuration depicted in FIG. **8** is for example purposes only, and other configurations are within the scope of the invention. An on-board back office **822** is preferably provided. Data is communicated by the on-board VSAT modem and transmitter to the first satellite for relay to the second (preferably land-based) VSAT receiver and modem. The data is then communicated to a server and/or centralized database via a mobile station controller (not shown).

A corresponding business model involves the gaming service provider contracting with a cruise line, which agrees to allow the gaming service provider to provide coverage throughout the cruise line's ship(s), by using repeaters for example. The gaming service provider may provide a private wireless network, in which case any revenue generated from use of or access to the private wireless network, and revenue from gaming activities, may be allocated among all or any subset of the cruise line and the gaming service provider. Alternatively, the gaming service provider may contract with a mobile carrier and a satellite provider, in which case revenue from the mobile calls, and revenue from gaming activities, may be allocated among all or any subset of the cruise line, the mobile carrier and the gaming service provider.

There are several scenarios for a user's activity relative to transactions conducted over the convenience gaming system. In one example scenario the user is in a fixed, but remote, location from the gaming server, which may be located on the premises of a casino. This may include, for instance, a situation in which the gaming communication device is a kiosk or some other communication device which is in a fixed position or which is tethered to a fixed position so that the gaming communication device cannot be moved beyond a certain area. In another example scenario, the user starts a convenience gaming transaction at a first location and ends the transaction at a second location different from the first location. In another example scenario, the user is mobile during a single convenience gaming transaction. In another example scenario, the user is mobile within a first approved area then (during the convenience gaming transaction) the user moves outside the first approved area, through an unapproved area, to a remote second approved area.

In another example embodiment, the convenience gaming system may be used to enable gaming activities involving multiple wireless users who interact with one another. For instance, the system may enable a table game (such as blackjack) in which a first user and a second user are conducting gaming transactions on the same table and in which options selected by the first user directly impact



outcomes and options relative to the second user. Preferably, the gaming environment presented on the gaming communication devices of both the first and second users will indicate the existence and activity of the other respective user. Another example of multiple users interacting on the convenience gaming system is the provision of a poker game in which users place bets against one another instead of, or in addition to, placing bets against the house. Another example of interaction between users is when a first user makes restaurant reservations or purchases event tickets, thereby reducing the options available to the second user.

Preferably, the gaming service provider provides at least the following functions. First, the gaming service provider provides and controls the one or more gaming servers. These servers may be physically located within the confines of the gaming service provider or may exist at a remote location. As mentioned, the gaming servers may also be located at or near a games provider such as a casino, casino hotel, racino, cruise ship, race track, etc. The gaming service provider may also provide monitoring services such as transaction monitoring and key stroke logging services. The gaming service provider may also provide data management and security services. These services are not intended to be exhaustive and the gaming service provider may provide other services which facilitate the convenience gaming process.

It should be noted that the invention can be implemented in connection with any gaming environment or an environment for any other activity, which may be conducted electronically. The invention is not limited to Nevada or any other particular gaming jurisdiction. For instance, the invention can be employed in connection with casinos in Atlantic City, N.J., international jurisdictions, Native American gaming facilities, and "racinos" which are race tracks that also have slot machines, video lottery terminals, or other gambling devices. For example, in connection with "racinos," the invention might be used by participants who wish to play slot machine games while they are viewing race horses in the paddock area. This might be desirable in the event that the slot machine area does not allow smoking and a participant wishes to gamble from an outdoor smoking area. Alternatively, the slot machine area might permit smoking and the gambler wishes to play the slot machines from an area where he or she can avoid breathing second-hand smoke. Numerous other scenarios can be envisioned in which the gaming participant can use the invention to participate in remote gaming, while enjoying some other primary activity in a location remote from the gaming facility.

Further, the invention is not limited to gaming, but can include other applications, such as trading financial instruments, and wagering on other types of events, such as elections, award events, or any other activity. More specifically, although the invention is described in the context of remote and/or mobile gaming, the principles of the invention are applicable to any system or method that uses wireless communications or other portable devices including handheld devices such as personal digital (or data) assistants (PDAs), computers, mini-computers, pagers, wireless terminals, mobile telephones, etc. Such systems may include electronic trading systems such as those used for trading financial instruments or any commodities.

In at least one embodiment, the invention provides jurisdictional controls, which limit gaming to approved geographical areas. The invention may also include an age/identity verification feature. This can be accomplished through any applicable technique including retina scanning, finger print identification, voice print matching, or other biometrics. Identity verification can also be accomplished by

having a customer take a picture of himself (e.g., by use of a digital picture phone) and transmitting the picture to the gaming service provider for comparison to a stored picture of the pre-approved user. Identity verification can also be accomplished by way of comparison of participant provided data to stored data, and execution of electronic agreements or contracts by the participant. The invention may also provide for the logging of keystrokes. In at least one embodiment, all communications are accomplished without accessing the Internet.

Mobile, remote gaming may be desirable for many reasons, some of which have already been described. The invention may allow supplementation of existing in-house gaming revenue by allowing bettors to place bets while enjoying other leisure activities such as golf, swimming, dining and shows. The invention may complement the new coinless wagering environment as bettors can play their favorite games outside the casino. The invention provides a high-speed, reliable, accurate, and secure mobile gaming environment that complies with regulatory requirements for identification and location verification of the bettor with the ability to generate key stroke logs. The invention may restrict unauthorized usage from a geographic perspective and is capable of implementation using location verification technology (e.g., geo fencing) to conform the gaming activities to legal parameters.

Consumers may benefit from an increased choice of gaming environments. Consumers will be able to bet in whatever surroundings they prefer, benefiting from the knowledge that the product is regulated, fair and secure while enjoying the gaming experience at the speed they choose without external influences, such as that which might occur within the in-house casino environment. The gaming businesses can use the invention to increase their revenue base through a new, regulated, mobile, remote channel. Customers wanting to be entertained during downtime or outside a casino will be able to play games on their gaming communication device and customers intimidated by a traditional casino environment will be able to play in private. The gaming jurisdictions may benefit from an increase in gaming an ancillary revenue growth because customers will have a more enjoyable experience.

The invention may also be used to deliver content at an increased speed compared to traditional telecommunications systems. The content may include, for example, live reports, entertainment, news, promotions and advertising.

As mentioned above, the invention provides a mobile gaming environment that complies with regulatory requirements for identification and location verification of the bettor. Moreover, the system is designed to be one hundred percent "clean" from a regulatory perspective. The software is clean in that it has not been and will not be licensed to anyone who does business illegally or otherwise operates in a "gray" area. For example, in a preferred embodiment, the software is not licensed to an entity that will illegally operate the software, or otherwise illegally do business on, the Internet. This may be desirable in that certain gaming jurisdictions will not grant gaming permits or licenses to companies that do business with, or license technology to or from, other entities known to be engaging in illegal operations.

Preferably, the system is designed such that the gaming software (or other application software operating on the system) is also one hundred percent clean from a regulatory perspective. For instance, before granting a license, a gaming jurisdiction may require that the software being used is not tainted in that it has not been used by the license

applicant in violation of any laws and has not been licensed or otherwise distributed or disseminated to others who have used the software for illegal purposes, or who have been engaging in illegal activity. Therefore, it is preferred that the gaming software be clean and untainted from this perspective.

The systems and methods described herein may also be used to deliver and/or access “Rich Media” content such as, for example, sports video (live or nearly live) and audio commentary. Such may often only be distributed within specific jurisdictions. Therefore, the distribution may benefit from the inventive aspects discussed herein, particularly the location verification aspect, such as geofencing.

The gaming system and methods described herein may permit, among other things, pari-mutuel wagering, sports betting, and dissemination of news and other content. The invention also enables a casino or other gaming provider to advertise ancillary services such as shows, bars, and restaurants. The invention also enables remote reservations and purchases in connection with such services.

According to some embodiments of the invention, the convenience gaming system provides for the dissemination of real-time odds to users accessing the system.

In other embodiments, an outcome in one transaction can trigger the presentation to the user of options for a second transaction. For example, if a user wins a predetermined amount of money playing blackjack, the user might be presented with an option to purchase retail items at a casino store or to make reservations for certain services at a club. As another example, if a user uses the system to purchase show tickets, the user might be offered to make reservations at one of several restaurants within a certain proximity to the show.

In some embodiments of the invention, access to the gaming device may be restricted unless a soft check and/or a hard check are performed. For example, in a soft check process, a user may be required to enter a valid user name and associated password, whereas in a hard check mechanism, the user may employ a physical token such as a card that identifies the user to the gaming device.

FIG. 9 illustrates an apparatus 920 to be used in conjunction with a gaming device 910 as part of a hard check mechanism according to the invention. Apparatus 920 may include any of a card which bears a magnetic strip (such as a credit card), a key that includes an RFID transponder, a limited-distance signal emitted or other transponder, a smart card that has a microprocessor or other circuit or “chip”, a bracelet or wristband which includes a signal transmitter such as an RFID signal transmitter, or which includes a magnetically encoded signal, a substrate that bears a bar code or other optically readable identifier, or any combination of the same.

For example, in some embodiments of the invention, apparatus 920 may be a magnet or a card bearing a magnetic strip (such as a credit card) or a smart card that has a microprocessor or other circuit or “chip” and which may be read by card reader 1010, which is part of gaming device 1000, as depicted in FIG. 10. Alternatively, such a card may be read by a contact-less device (e.g., a signal reader which receives and interprets signals transmitted by the card).

Apparatus 920 may therefore be capable of producing a signal that is detectable by a gaming communication device such that access to the gaming device is provided when the signal is detected. Access to the gaming device may be provided for a predetermined period of time after the signal is initially detected or so long as the signal continues to be detected. The signal produced by apparatus 920 may addi-

tionally or alternatively communicate identifying information stored on the apparatus. Such information may be communicated through a transponder or any other suitable emitter. Access to the gaming device may be provided when the identifying information is associated with a user that is authorized to operate the gaming communication device. Such identifying information may be stored on apparatus 920.

Moreover, the signal produced by apparatus 920 may additionally or alternatively communicate characteristics associated with the authorized user. These characteristics may include the average volume wagered by the user, whether the user is a high-volume, medium-volume or low-volume wagerer, the user’s wagering performance, whether the user is a member of a club affiliated with the organization that distributed the apparatus to the user. User characteristics may be stored and updated on apparatus 920 and/or device 910 as the user enters into more wagers and transactions, thereby enabling the provision of yet another layer of security for the device. For example, even after the initial soft and hard checks are successful, the user may subsequently be denied access to device 910 if the updated information does not fall within a predetermined range of acceptable characteristics or does not substantially match ongoing wagering requirements within a predetermined degree of tolerance. Alternatively or additionally, a certain number of deviation occurrences, which may be communicated by device 910 or merely calculated based on the updated characteristics as communicated by device 910, may trigger an alarm signal generated at a security center. This signal may lead to increased surveillance of the user or may cause security or gambling facility personnel to take action vis-a-vis the user.

Alternatively, the signal produced by apparatus 920 may be compatible with a certain class of devices (e.g., gaming devices associated with a relatively higher limit, if at all, on the amounts allowed to be wagered). Before being provided with the apparatus, a user may be required to provide identifying information (e.g., a user I.D.). Upon receipt of this information, a provider such as a gambling facility, may retrieve a user record or profile containing characteristics associated with the user and the information provided. The user may then be provided with an apparatus that corresponds to the retrieved characteristics. An example of such a verification process relating to wagering is discussed below.

In some embodiments of the invention, apparatus 920 does not produce any signal. Instead, apparatus 920 may be a storage device or storage medium such as tape, memory, a disk, etc. and gaming device 910 may have a reader capable of extracting information such as a compact disk or other disk or tape reader, or any other card reader or device capable of extracting information stored on such a storage mechanism.

In some embodiments of the invention, apparatus 920 may also serve other functions. In addition to, or as an alternative to, securing access to a wireless gaming device, apparatus 920 may use the same mechanisms described herein to communicate with a gaming station or other interface. For example, apparatus 920 may be associated with information that grants the user access to certain non-mobile gaming devices, certain areas within a casino or a hotel, a particular nightclub or restaurant, a particular room or suite, etc., or serve as a user or player tracking card, e.g., a “comp card”.

In other embodiments of the invention, apparatus 920 may be a bracelet or wristband such as bracelet 1100

depicted in FIG. 11. Bracelet 1100 can be made of many types of material, such as rubber, plastic, metal or any combination thereof. Bracelet 1100 may be adapted for single-use or multiple uses. The ends of the bracelet may be attachable at point 1111 such that the bracelet can be affixed to or worn on, e.g., the wrist of a user of the game device. For example, bracelet 1100 may have adhesive on one end, allowing that end to be adhered to the other end when the bracelet is formed into a loop around the user's wrist.

The bracelet may include a chip, transmitter or transponder which emits a signal that identifies the user (e.g., by emitting a signal that represents a unique identifier such as a signal that represents a sequence of alphanumeric characters). In such embodiments, the bracelet, when worn by a user of the gaming device, can emit a signal that is received by the gaming device, which in turn informs the gaming device that the wireless gaming device is being used by an authorized user (e.g., the user associated with the unique identifier transmitted by the bracelet).

The bracelet may operate only for the period during which it is worn by a user. For example, the bracelet or gaming device may include a device which permits detection of whether the bracelet is in a looped position with its ends adhered to each other. This can be advantageous where it is desirable to determine, after a bracelet has been worn by a user, whether the bracelet has been removed by the user (because the ends of the bracelet are no longer in contact with each other). In some embodiments of the invention, a very low amperage current can be passed through the bracelet through a transmitter or battery in the bracelet. Thus, if the bracelet is worn by a user, the ends of the bracelet will be electrically connected and a closed circuit will be formed thereby causing current to flow through the circuit. Such a current can be detected by the gaming device. In other embodiments, the magnetic field of the circuit can be detected by the gaming device. If the circuit is broken or otherwise disengaged, indicating that the user has probably removed the bracelet, then the hard check can fail, and the user must pass the hard check in another manner (e.g., by obtaining another bracelet). The bracelet may or may not be permanently disabled upon removal.

The bracelet may have visual or other indicator or indicia associated with user characteristics. Accordingly, different users may be handed out bracelets having different colors, dimensions, sizes, styles, etc. based on their gaming, or other, traits. For example, upon verification of user identity and/or retrieval of user record, a user that wagers or trades in high volumes may be given a bracelet having a different color than that given to a user that wagers or trades in lower volumes.

In some embodiments, the gaming device may be configured to provide a recognizable visual, audio and/or other signal when access to the device is provided through the bracelet (i.e., when the hard check is successful) or merely when the device is within a certain distance from the bracelet. For example, an LED on the gaming device may be enabled when access is provided. As another example, the device may produce a blinking light, a beeping sound and/or may vibrate when the device is capable of detecting the bracelet and/or when the user actuates a locator button on the device. Actuation of such a button may also be part of a sequence of steps taken to unlock the device.

In some embodiments of the invention, the gaming device may be programmed to recognize one or more particular bracelets at the time the wireless gaming device is registered to be provided to a user. In such embodiments, the gaming device may be selected or determined to match or corre-

spond to the unique identifier of the particular bracelet. For example, a unique identifier may be stored by, coded into, or programmed into the wireless gaming device.

In other embodiments of the invention, a unique identifier, and/or user characteristics, are coded into the bracelet at the time the wireless gaming device is registered to be provided to a user. In these embodiments, the identifier of the bracelet would be set to match, correspond to or otherwise be recognized by, the wireless gaming device.

In some embodiments of the invention, the identifiers associated with a hard check apparatus (e.g., a bracelet as discussed above) are stored on a server or other device that the wireless gaming device can access. In other embodiments, the wireless gaming device does not store such identifiers. Information conveyed from the apparatus to the wireless gaming device may be checked, compared to predetermined criteria or matched locally (i.e., at the wireless gaming device by, e.g., the device itself) or remotely through, e.g., a server which can authenticate users and communicate back with the device. For example, such information may be transmitted across network 16 of FIG. 1 and may be processed by computer 18.

In some embodiments of the invention, the identifier associated with a particular apparatus (e.g., bracelet) allows one or more accounts of the user to be recognized and accessed. For example, an account that stores or manages the "comp points" of the user may be determinable by, and accessible from, the wireless gaming device. Thus, the user may wager using the wireless gaming device and also have her comp points manipulated (e.g., added to in accordance with her use of the wireless gaming device).

The wireless gaming device can be programmed to determine the form of hard check used (e.g., from a bracelet instead of from a comp card with a magnetic stripe). For example, the manner of input may provide such a determination (e.g., an identifier received via an integrated card reader as depicted in FIG. 10 indicates that the hard check is performed via a card, while an identifier received via an RFID transponder indicates that the hard check is performed via a bracelet as depicted in FIG. 11). Alternatively or additionally, the form of hard check may be coded into the identifier. For example, identifiers that begin with the number "1" may indicate that the hard check is via a card, while identifiers that begin with the number "2" indicate that the hard check is via a bracelet.

Although this disclosure has been described in terms of certain embodiments and generally associated methods, alterations and permutations of these embodiments and methods will be apparent to those skilled in the art. Accordingly, the above description of example embodiments does not define or constrain this disclosure. Other changes, substitutions, and alterations are also possible without departing from the spirit and scope of this disclosure.

What is claimed is:

1. An apparatus comprising:

a magnetic reader;

at least one processor to:

receive, via the magnetic reader, a signal representative of an identifier associated with a user from a transmitter of a bracelet;

detect whether a current is flowing through the bracelet; in response to determining that the identifier is valid and that the current is flowing through the bracelet, authorize the user to enter a particular location;

in response to determining that the identifier is invalid or that the current is not flowing through the bracelet, deny the user from accessing the particular location; and

generate a visual or audible signal that indicates the user is authorized to enter or denied entry to the particular location. 5

2. The apparatus of claim 1, wherein the at least one processor is further configured to receive characteristics associated with the user from the bracelet. 10

3. The apparatus of claim 2, wherein the at least one processor is configured to receive updates on the characteristics associated with the user.

4. The apparatus of claim 2, wherein the characteristics comprise at least one of average volume wagered by the user, a wagering performance of the user, or a certain number of deviation occurrences. 15

5. The apparatus of claim 1, wherein the at least one processor is configured to transmit to a server the identifier and an indication of whether the current is flowing through the bracelet. 20

6. The apparatus of claim 1, wherein the at least one processor is further configured to permanently forbid the bracelet from being used to access the particular location, in response to determining that the current is not flowing through the bracelet. 25

7. The apparatus of claim 1, wherein the at least one processor is further configured to receive a further indication that the signal is coming from a bracelet.

\* \* \* \* \*