

(19) DANMARK

(10) DK 2016 70961 A1



(12) PATENTANSØGNING

Patent- og
Varemærkestyrelsen

-
- (51) Int.Cl.: *E 04 D 13/147 (2006.01)* *E 04 D 13/03 (2006.01)*
- (21) Ansøgningsnummer: PA 2016 70961
- (22) Indleveringsdato: 2016-12-05
- (24) Løbedag: 2016-12-05
- (41) Alm. tilgængelig: 2018-06-06
- (71) Ansøger: VKR Holding A/S, Breelevevej 18, 2970 Hørsholm, Danmark
- (72) Opfinder: Bent Atzen, Novembervej 12, 8700 Horsens, Danmark
Lars Erdmann, Skovdalsvej 2, 8260 Viby J, Danmark
Jens-Ulrik Holst Henriksen, Fuglesangs Alle 15, 8210 Århus V, Danmark
- (74) Fuldmægtig: AWA Denmark A/S, Strandgade 56, 1401 København K, Danmark
- (54) Benævnelse: **A sealing collar for being mounted around a window frame mounted in an inclined roof of a building, and a method for mounting a window frame**
- (56) Fremdragne publikationer:
EP 2284329 A2
EP 2508690 A1
EP 0874101 A1
EP 0994992 B1
GB 2388399 B
- (57) Sammendrag:
The invention relates to a sealing collar (10) adapted for being mounted around a window frame (3) mounted in an inclined roof of a building, and to a method for mounting a window frame (3) using such a sealing collar. The sealing collar comprises an inner portion (11) having an inner edge which defines an opening and which is adapted for surrounding the window frame, and an outer skirt portion (12) attached to the outer edge of the inner portion and made from a waterproof membrane. Top, bottom and side members of the inner portion are made from a substantially dimensionally stable material and the shape and size of the opening substantially matches shape and size of the window frame, when the sealing collar is in the mounted condition, so that the inner edges of the inner portion may be used as a guide for a drawing aid or cutting tool.

Fortsættes ...

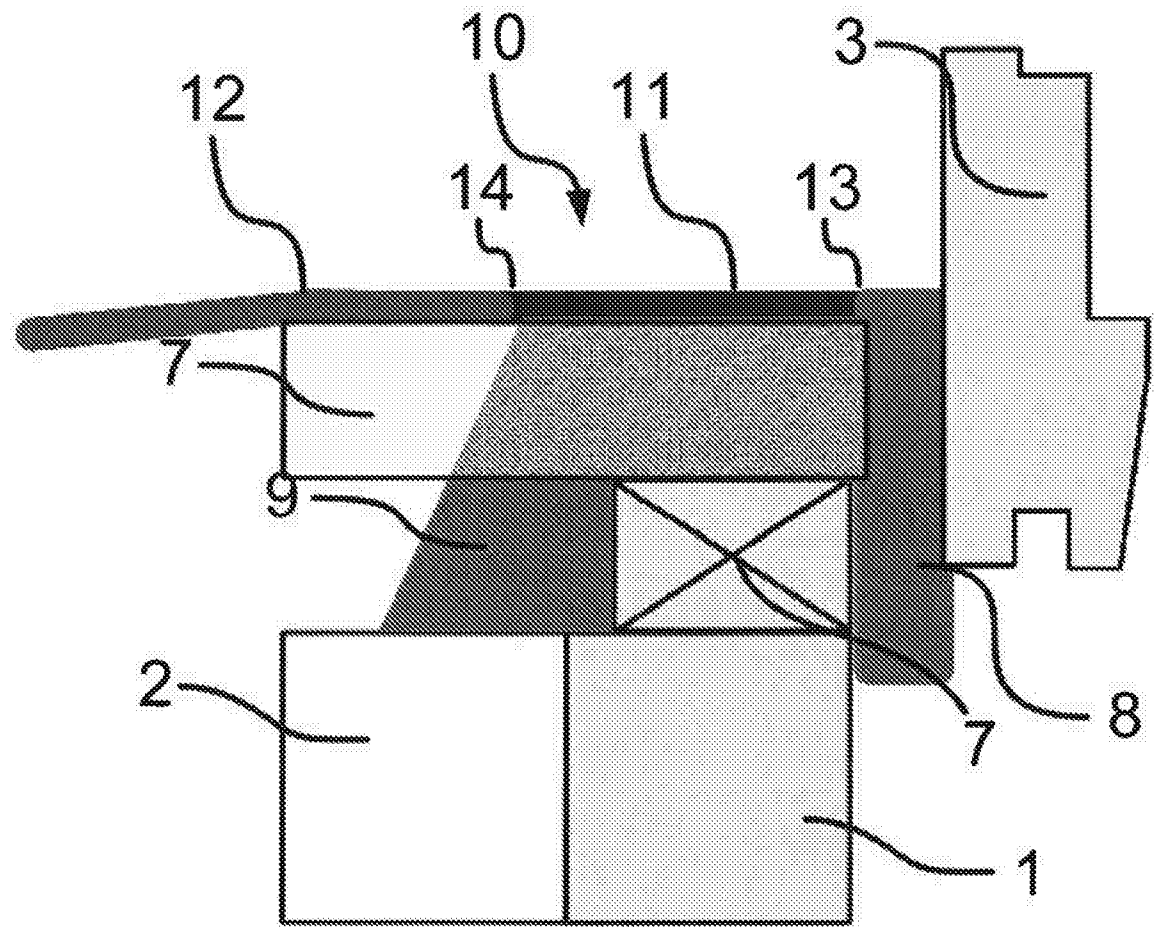

Fig. 3

The present invention relates to a sealing collar adapted for being mounted around a window frame mounted in an inclined roof of a building, where said sealing collar comprises an inner portion having top, bottom and side members, where said inner portion has an inner edge and an outer edge opposite the inner edge, where said inner edge defines an opening when the sealing collar
5 is in the mounted condition, where said inner portion is adapted for surrounding a window frame, and where an outer skirt portion is attached to the outer edge of the inner portion, where said outer skirt portion is a waterproof membrane adapted for forming a waterproof transition to an underroof of the inclined roof.
10 The invention further relates to a method for mounting a window frame using such a sealing collar.

During the installation of a window in an inclined roof including an underroof, an opening for the window frame is cut in roof battens and the underroof. In order to make the transition between the installed window frame and
15 the underroof waterproof and prevent water leakage into the roof construction, a sealing collar also known as an underroof collar is applied. Such a sealing collar is known from the applicant's EP patent no 0 994 992 B1.

The sealing collar is installed after the window frame, and possibly an insulation frame, has been installed in the opening. During the installation, the
20 sealing collar is pulled over the window frame and attached to the outer side of the window frame. To prevent water leakage into the opening, the sealing collar must be in close engagement with the outer side of the window frame and the underroof of the roof structure. The prevention of water leakage is therefore contingent on a careful installation of the sealing collar, which means that the
25 process is susceptible to errors caused by improper handling and time constraints.

Moreover, cutting the opening in the roof for the window involves calculating the required size of the opening and subsequent transfer of markings to the roof to be used as guiding pattern for cutting roof battens. The calculation
30 and transfer of markings is associated with a risk of error, causing the opening to have the wrong dimensions.

The installation of the sealing collar after the window frame and the

cutting of the opening in the underroof provides two sources of errors which may result in water leaking through the roof structure.

It is an object of the invention to provide a sealing collar, which facilitates the installation process and reduces the risk of error during installation.

5 In a first aspect, this and further objects are met by a sealing collar of the kind mentioned in the introduction, which is furthermore characterized in that the top, bottom and side members of the inner portion are made from a substantially dimensionally stable material, wherein both shape and size of the opening substantially matches shape and size of the window frame, when the
10 sealing collar is in the mounted condition, so that the inner edges of the inner portion may be used as a guide for a drawing aid or cutting tool..

The reference to the shape and size of the window frame is to be understood as a reference to a window frame including possible insulating material provided on or at its outer side. The opening defined by the inner portion
15 then matches the shape and size of whatever of these objects has the largest circumferential dimension in a plane parallel with the roof.

In this manner, the sealing collar can be placed directly at an intended position of the window, an outline of an opening matching the size and shape of the window frame can be transferred to the roof battens by following the inner
20 edge of the inner portion with a pencil, pen or like drawing aid. An opening can then be cut in the roof battens by following the outline or guiding pattern drawn. The size and shape of the opening cut in the roof then matches the outer edge of the window frame, without the need for calculations.

Alternatively, the inner edge of the inner portion can be used as guid-
25 ing means for cutting the roof battens, by letting a cutting device, e.g. a saw, follow an inner edge of the inner portion. An opening matching the size and shape of the outer edge of the window frame is then cut without the need of markings or calculations.

Cutting directly following the shape of the inner edge of the inner por-
30 tion has the advantage that the step of drawing the guiding pattern is eliminated, but involves the risk of damaging the sealing collar. Drawing a line to be

followed when cutting is the safer option but necessitates the removal and subsequent removal of the sealing collar. Which option is the most advantageous therefore depends on several factors such the skill of the person doing the installation, the nature of the roof construction etc.

5 By “dimensionally stable material” is meant that the dimensions of the individual members are not easily unintentionally changed, e.g. as a consequence of the members being bent, folded or creased during transport, handling or installation. Also, by “dimensionally stable” is meant that the size and shape of the opening defined by the inner portion in the mounted condition
10 does not unintentionally differ from the size and shape of the window frame. By “dimensionally stable” is also meant that the top, bottom and side members of the inner portion are made from a material, which is substantially incompressible when a pencil, saw or the like is abutted against the inner edge. Incompressibility of the material facilitates a transfer of markings, substantially matching the size and shape of the opening defined by the inner portion.
15

The top, bottom and side members of the inner portion may be provided as individual components being joined in situ before installing the sealing collar. Alternatively, the top, bottom and side members of the inner portion may be provided as a single entity, e.g. molded or cast in plastic. Providing the inner
20 portion as a single entity, e.g. premanufactured, is presently the preferred method, as it eliminates the potential of error during assembly.

The two sides of the sealing collar need not be identical. As an example a sealing collar, where there is no outer skirt at one side, may be employed where two windows are mounted closely side-by-side. Likewise, as there will
25 typically be different requirements for the function of the sealing collar at the top and at the bottom, the top and bottom member of the inner portion and/or outer skirt may be embodied differently.

The inner portion of a sealing collar for use when mounting standard size roof windows in residential building will typically have a width measured
30 from the inner edge to the outer edge of approximately 5-15 cm and a thickness of 0,025-0,1 cm, corresponding to a thickness:width ratio of between 1:50 and 1:600. The optimal dimensions will, however, depend on the materials used.

The sealing collar may be provided with means to adapt the size of the inner portion, in order to accommodate window frames of various sizes. The adaptation means may be provided in the form of telescopic means, where one part of at least one of the top, bottom or side members can slide in relation to
5 another part of the same member and thereby change the dimension of said member.

The telescopic means may be provided in an alternatively manner, where one inner portion member, e.g. a side member, is attached to its neighboring members, e.g. top and bottom member, through sliding members. The
10 inner portion member can then slide on its neighboring members in order to change the dimensions of the opening defined by the inner portion. The telescopic means may be provided for either a continuous or a step-wise adaptation of the dimension of the inner portion member.

Adaptation of the dimensions of a member of the inner portion may
15 also be attained as an unfolding or folding of material. The inner portion may be provided with material folded onto each other, the material is then unfolded to change the dimensions of a member of the inner portion or vice versa.

It is also possible to provide the top, bottom and/or side members of the inner portion with weakening or hinges, which allows them to bend in pre-
20 defined places. This will facilitate handling during installation of the sealing collar, and the sealing collar may even be delivered with one or more of these members in a bent state in order to keep the size of the sealing collar at a minimum during storage and transportation.

The sealing collar may be attached to the roof battens using staples,
25 screws, nails or adhesives in a manner known per se. Attaching the sealing collar to the roof battens may be done before cutting the roof battens to ensure a stable position of the sealing collar when performing the cutting. The sealing collar may also be attached after the roof battens have been cut.

As the sealing collar does not overlap with the window frame it may be
30 advantageous to include one or more transitional members adapted for interconnecting the inner portion and/or outer skirt to a window frame. This may for example be in the of an additional sheet of material arranged in parallel with

the outer skirt in the state of delivery and adapted for being folded back over the inner portion and up along the outer side of the window frame when the window frame has been installed. The transitional member(s) may be provided with a strip of adhesive material adapted for attachment to the outer side of the
5 frame.

A transitional member may also be provided as an independent part and delivered as a kit together with the sealing collar.

It is also possible to include one or more insulation members on the sealing collar. As described for the transitional members these may advantageously be connected to the outer skirt and/or inner portion in a manner, which
10 allows them to be folded or swung into position when at least the inner portion has been correctly mounted. The insulating members will normally cover the window frame at least partly, and mainly extend below the level defined by the inner portion of the sealing collar in the mounted state. In one embodiment the
15 sealing members are adapted for be arranged in the opening cut in the roof so as to provide insulation between the window frame and the roof construction. One or more insulation members may be connected to the inner portion and/or outer skirt via one or more insulating member holder(s) and to ensure correct positioning the insulating member holder(s) preferably has/have predefined di-
20 mensions, which allow the insulating member(s) to be moved between a delivery position, where it/they are located on an exterior side of the inner portion and/or outer skirt, and an installed position, where it/they are located inside the opening defined by the inner edge of the inner portion.

Transitional members and/or insulating member holders can be at-
25 tached at the joint between the inner portion and the outer skirt, thereby minimizing the number of joints, but it is to be understood that they are independent so that one may be present without the other and that they may be attached differently.

The inner portion may comprise a stiffening member in order to provided
30 the needed properties. It presently considered advantageous to provide a stiffening member extending along the joint between the inner portion and the outer skirt, particularly if other members are attached at this joint as described above,

but it may also be advantageous to provide a stiffening member at the inner edge.

The inner portion can be made from any material, which has the needed properties with respect to strength and stiffness described above. It is, however, preferred that the material has a low heat conductivity and that it is resistant to temperature variation and the like, which occurs in a roof construction. Mouldable plastic materials such as polypropylene, polyethylene or polyvinylchloride, are presently preferred, but other materials including composite and wood may also be employed.

The stiffing member, if any, may advantageously be made from the same material as the inner portion, but may also be made from other materials such as for example plywood or even metal.

The material or materials used for the outer skirt can be any, which is suitable for providing a water-tight connection to the underroof and which is compatible with the material used for the inner portion. The outer skirt may be made wholly or partially from a pleated material as is well-known from the prior art, including embodiments where only side members of the outer skirt are made from a pleated material while the top and bottom members are unpleated. The insulation holder, if any, will typically be made from the same material as the outer skirt, but in some embodiments it will only serve a function during the installation process and it can then be made from a relatively cheap material as will be elaborated below.

In a second aspect of the invention the object is achieved with a method for installing a window frame in an inclined roof of a building comprising the steps of:

providing a sealing collar comprising an inner portion having top, bottom and side members, where said inner portion has an inner edge and an outer edge opposite the inner edge, where said inner edge defines an opening when the sealing collar is in the mounted condition, where said inner portion is adapted for surrounding a window frame by the inner edge, and where shape and size of the opening substantially matches shape and size of the window frame, and an outer skirt portion attached to the outer edge of the inner portion,

where said outer skirt portion is a waterproof membrane adapted for forming a waterproof transition to an underroof of the inclined roof, ,

placing the sealing collar at an intended position for the window frame,
using the inner edge of the inner portion, which made from a substan-
5 tially dimensionally stable material, as a guide for a drawing aid or a cutting
tool, either transferring a guiding pattern to roof battens and/or underroof of the
inclined roof or cutting an opening in the roof battens and underroof directly.

Details and embodiments described with reference to the first aspect
of the invention above also apply to second aspect of the invention unless spe-
10 cifically state otherwise. In the following the invention will be described in more
detail by way of example and with reference to the schematic drawings, where:

Fig. 1 shows a frontal view of the sealing collar installed on a roof con-
struction,

Fig. 2 shows a frontal view of the sealing collar with a window frame,

15 Fig. 3 shows a sectional view of the sealing collar along the line III-III
in Fig. 1, and

Fig. 4 shows a perspective view of the sealing collar and window frame
along the line IV-IV in Fig. 1. Fig. 1 shows an embodiment of the sealing collar
10 arranged on a roof structure 1. The sealing collar 10 comprises an inner
portion 11 and an outer skirt 12, and said inner portion 11 has an inner edge
20 13 and an outer edge 14 opposite the inner edge 13. The outer skirt 12 of the
sealing collar 10 is attached to the inner portion 11 along the outer edge 14.
The inner portion 11 has top 15, bottom 16 and side 17, 18 members. The top
15, bottom 16 and side 17, 18 members defines an opening 20, which substan-
25 tially matches the size and shape of a window frame.

In Fig. 1 it is shown how a saw 21 follows the inner edge 13 of the
inner portion, thereby cutting the battens 7 and forming an opening in the roof
structure 1 substantially matching the size and shape of a window frame to be
mounted in the roof. The underroof may be cut simultaneously with the battens
30 or in a separate step.

The top 15, bottom 16 and side 17, 18 members are constructed from

a dimensionally stable, i.e. substantially incompressible, material, such as plastic, such that the size and shape of the opening does not change when inner portion is used as a guide for cutting as in Fig. 1 or for drawing if choosing to cut following a guiding pattern rather than the inner edge of the inner portion.

5 The outer skirt 12 of the sealing collar 10 is a waterproof membrane. The waterproof membrane may be made of any suitable, flexible, waterproof sheet material or length of material. Such suitable materials could be polyolefine based plastic materials.

10 A watertight transition to the roof structure 1 may be achieved by having the outer skirt 12 constructed in a pleated manner, where sections of the outer skirt 12 overlaps each other. The surplus material of the outer skirt 12 enables a waterproof transition from the window frame 3 without having to remove roof battens 7 or if an underroof is uneven. The waterproof transition is attained as the pleated manner allows the outer skirt 12 be placed around the roof batten
15 7 and form a close engagement with the roof battens 7, without any modifications.

 The pleated manner of the outer skirt 12 is inconsequential for the function of the inner portion. The material of the outer skirt 12 may therefore be pleated in sections as in the present embodiment, at the full circumferential
20 direction or not at all.

 Fig. 2 shows the sealing collar 10 mounted around a window frame 3. As may be seen the dimensions of the opening 20 matches the dimensions of the window frame 3 and the sealing collar surrounds the window frame 3 with the inner portion 11 abutting against the outer side of the window frame 3.

25 In the embodiment of Fig. 2 the inner portion 11 of the sealing collar 10 is provided as single integrated entity. Alternatively, the sealing collar 10 may be provided as individual members, i.e. the inner portion 11 and outer skirt 12 are assembled during installation.

 Whereas the embodiment in Fig. 1 has an inner portion with a bottom
30 member 16 of reduced width in order to make room for flashing members, the top, bottom and side member of the inner portion in Fig. 2 are all of the same width.

As will also be seen, the top member of the outer skirt is considerably wider than the side and bottom members in both the embodiment in Fig. 1 and that in Fig. 2. This is order to ensure excellent water-tightness.

Fig. 3 shows how the inner member 11 defines an opening that
5 matches the size and shape of an insulation frame 8 installed at the outer edge of the window frame 3. The outer skirt 12 of the sealing collar 10 is attached to the inner member 11. An additional insulation member 9 is provided between and over the roof battens 7 to further thermally insulate the window frame 3. The window frame 3 is mounted in a roof structure 1, which has an insulation
10 member 2.

A connection between the outer edge 14 of the inner portion 11 and the outer skirt 12 may be attained by welding the two components together.

The width from the inner edge 13 to the outer edge 14 of the inner member 15, 16, 17, 18 may be in an interval of 3 to 20 cm, i.e. 8 cm. Independ-
15 ent of the dimensions of the inner member may be formed from a materiel that prevents the formation of a thermal bridge between the outside of the window frame and the inside, this could be plastic, a composite or a reinforced textile.

A specific embodiment of the sealing collar 10 is shown in Fig. 4. The inner portion 11 defines an opening that in size and shape matches the window
20 frame 3 with an associated insulation frame 8. The sealing collar 10 is provided with a stiffening member 21, that supports the contact between the inner portion 11 and the outer skirt 12. The stiffening member 21 may be provided as an individual member or as an integrated member of either the inner portion 11 or the outer skirt 12.

25 The embodiment shown in Fig. 4 is provided with a transitional element 22 from the window frame 3 to a top side of the outer skirt 12. The transitional element 22 assists in the attainment of a watertight installation. To ensure a watertight transition, the transitional element 22 may be welded onto either the inner portion 11, the outer skirt 12, the stiffening member 21 or the insulation
30 frame holder 23, during the installation. The transitional element 22 may be provided as an integrated element of the sealing collar 10 or as an individual element. The transitional member may be optional, but is preferred in order to

the most watertight installation.

For the embodiment shown in Fig. 4 the sealing collar 10 is provided with an insulation member holder 23, which attaches to a top side of the stiffening member 21 and connects to the insulation member 8 in order to hold the
5 insulation member 8. The insulation member holder 23 may be provided as an integrated member of the sealing collar 10 or as an individual member. The insulation member holder 23 may also be provided when the stiffening member 21 is not included in the sealing collar 10.

In Figs. 3 and 4 the insulation member 8 is provided as a member of
10 the sealing collar 10, which is attached to the exterior side of the sealing collar 10 and is folded into the opening 20 after the roof battens 7 have been cut.

In an alternative embodiment of the sealing collar 10, the insulation member 8, the insulation member holder 23 and the transitional element 22 are folded onto the exterior of the sealing collar 10 in their reverse installation order.
15 During the installation the insulation member 8 and the insulation member holder are folded into the opening 20 and the transitional element 22 is folded onto the window frame 3.

Finally, it should be mentioned that suitable application of the present invention not is limited to window frame, but also alternative roof penetrating
20 structures, e.g. chimneys and roof hatches.

P A T E N T K R A V

1. A sealing collar (10) adapted for being mounted around a window frame (3) mounted in an inclined roof of a building, said sealing collar comprising

5 an inner portion (11) having top, bottom and side members, where said inner portion has an inner edge and an outer edge opposite the inner edge, where said inner edge defines an opening when the sealing collar is in the mounted condition, and where said inner portion is adapted for surrounding a window frame by the inner edge, and

10 an outer skirt portion (12) attached to the outer edge of the inner portion, where said outer skirt portion is a waterproof membrane adapted for forming a waterproof transition to an underroof of the inclined roof,

characterized in that the top, bottom and side members of the inner portion are made from a substantially dimensionally stable material, wherein
15 shape and size of the opening substantially matches shape and size of the window frame, when the sealing collar is in the mounted condition.

2. A sealing collar according to claim 1, further including a transitional member (22) adapted for interconnecting the inner portion (11) and/or outer skirt (12) to a window frame (3).

20 3. A sealing collar according to one or more of the preceding claims, further including one or more insulation members (8).

4. A sealing collar according to claim 3, where one or more insulation members (8) are connected to the inner portion (11) and/or outer skirt (12) via one or more insulating member holder(s) (23).

25 5. A sealing collar according to claim 4, where the insulating member holder(s) (23) has/have predefined dimensions, which allow the insulating member(s) to be moved between a delivery position, where it/they are located on an exterior side of the inner portion and/or outer skirt, and an installed position, where it/they are located inside the opening defined by the inner edge of
30 the inner portion.

6. A sealing collar according to one or more claims 2-5, where the transitional member (22) and/or insulating member holder(s) (23) is/are attached

at the joint between the inner portion (11) and the outer skirt (12).

7. A sealing collar according to one or more of the preceding claims, where the inner portion (11) comprises a stiffening member (21), preferably extending along the joint between the inner portion (11) and the outer skirt (12).

5 8. A kit including a sealing collar according to one or more of claims 1-7 and a transitional collar (22) with one edge adapted for being connected to the sealing collar and another edge adapted for being connected to a window frame (3).

9. Method for installing a window frame (3) in an inclined roof of a building comprising the steps of:

10 providing a sealing collar (10) comprising an inner portion (11) having top, bottom and side members, where said inner portion has an inner edge and an outer edge opposite the inner edge, where said inner edge defines an opening when the sealing collar is in the mounted condition, where said inner portion
15 is adapted for surrounding a window frame by the inner edge, and where shape and size of the opening substantially matches shape and size of the window frame, and an outer skirt portion (12) attached to the outer edge of the inner portion, where said outer skirt portion is a waterproof membrane adapted for forming a waterproof transition to an underroof of the inclined roof, ,

20 placing the sealing collar (10) at an intended position for the window frame,

using the inner edge of the inner portion (11), which made from a substantially dimensionally stable material, as a guide for a drawing aid or a cutting tool, either transferring a guiding pattern to roof battens and/or underroof of the
25 inclined roof and then cutting along the guiding pattern or cutting an opening in the roof battens and underroof directly, and

mounting the window frame in the opening cut in the roof.

30 10. A method according to claim 9, further including the step of moving insulating members attached the inner portion and/or outer skirt from a delivery position, where they are located on an exterior side of the inner portion and/or outer skirt, to an installed position, where it/they are located inside the opening defined by the inner edge of the inner portion before the window frame is

mounted.

Awapatent A/S

1/3

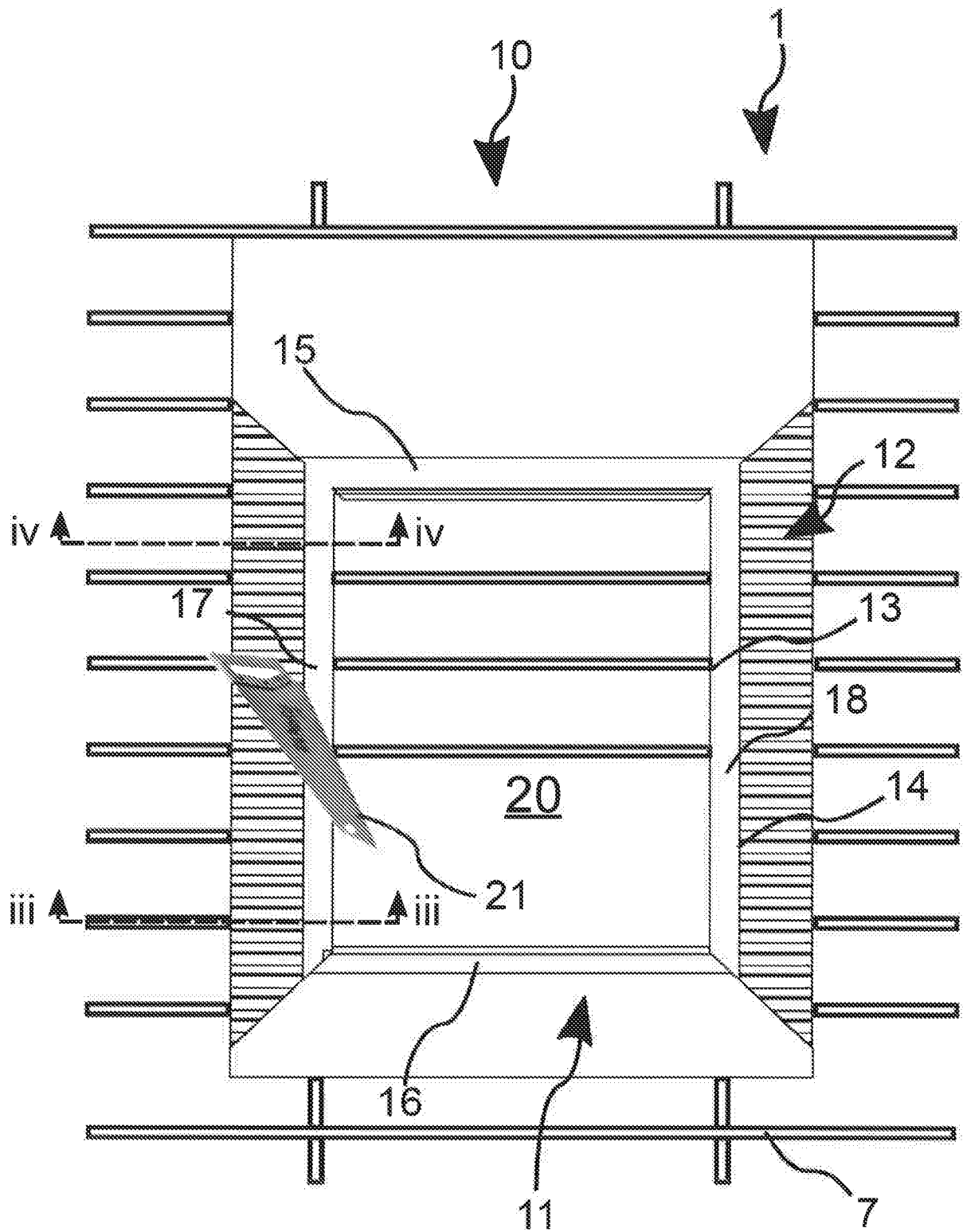

Fig. 1

2/3

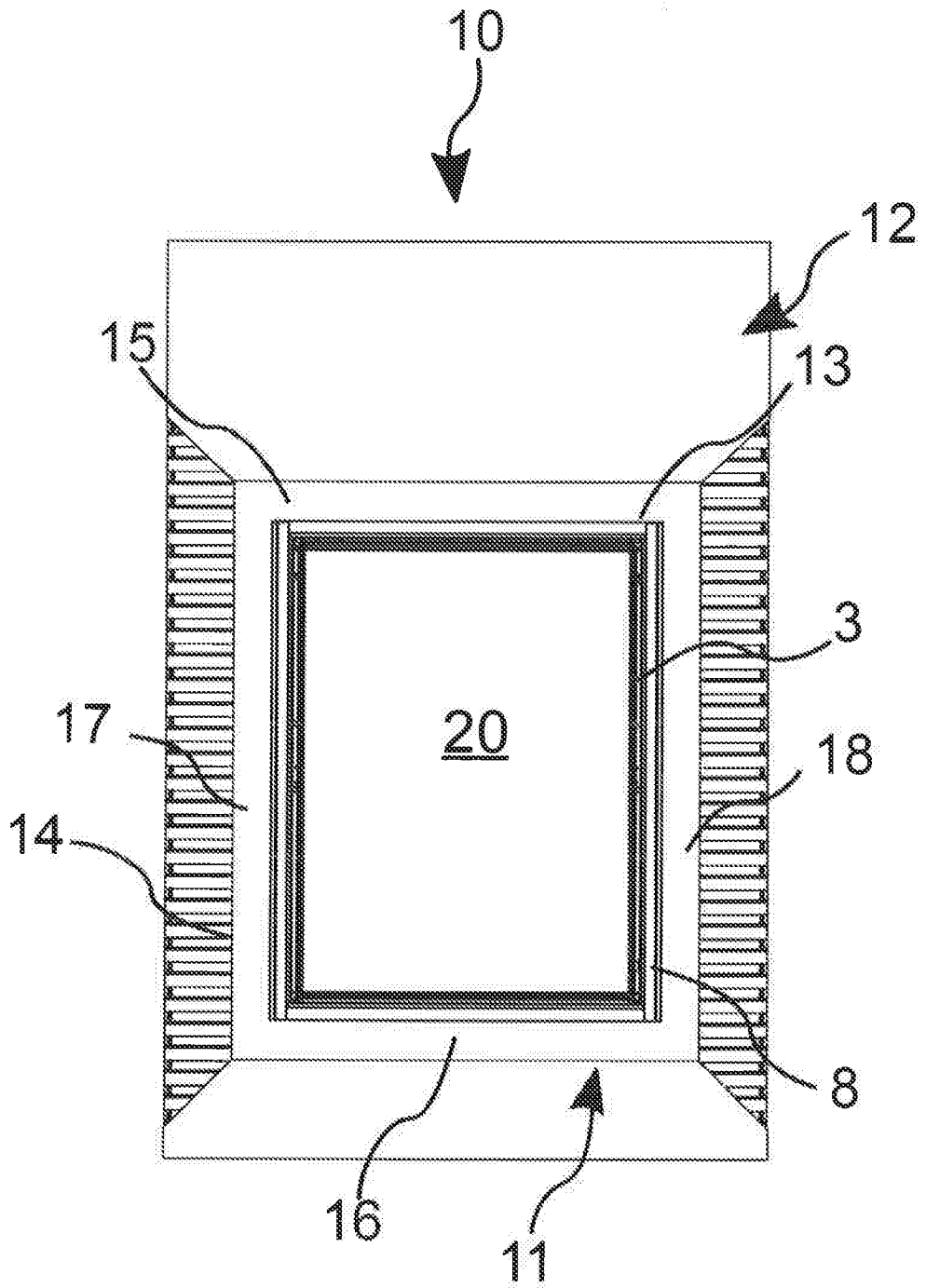

Fig. 2

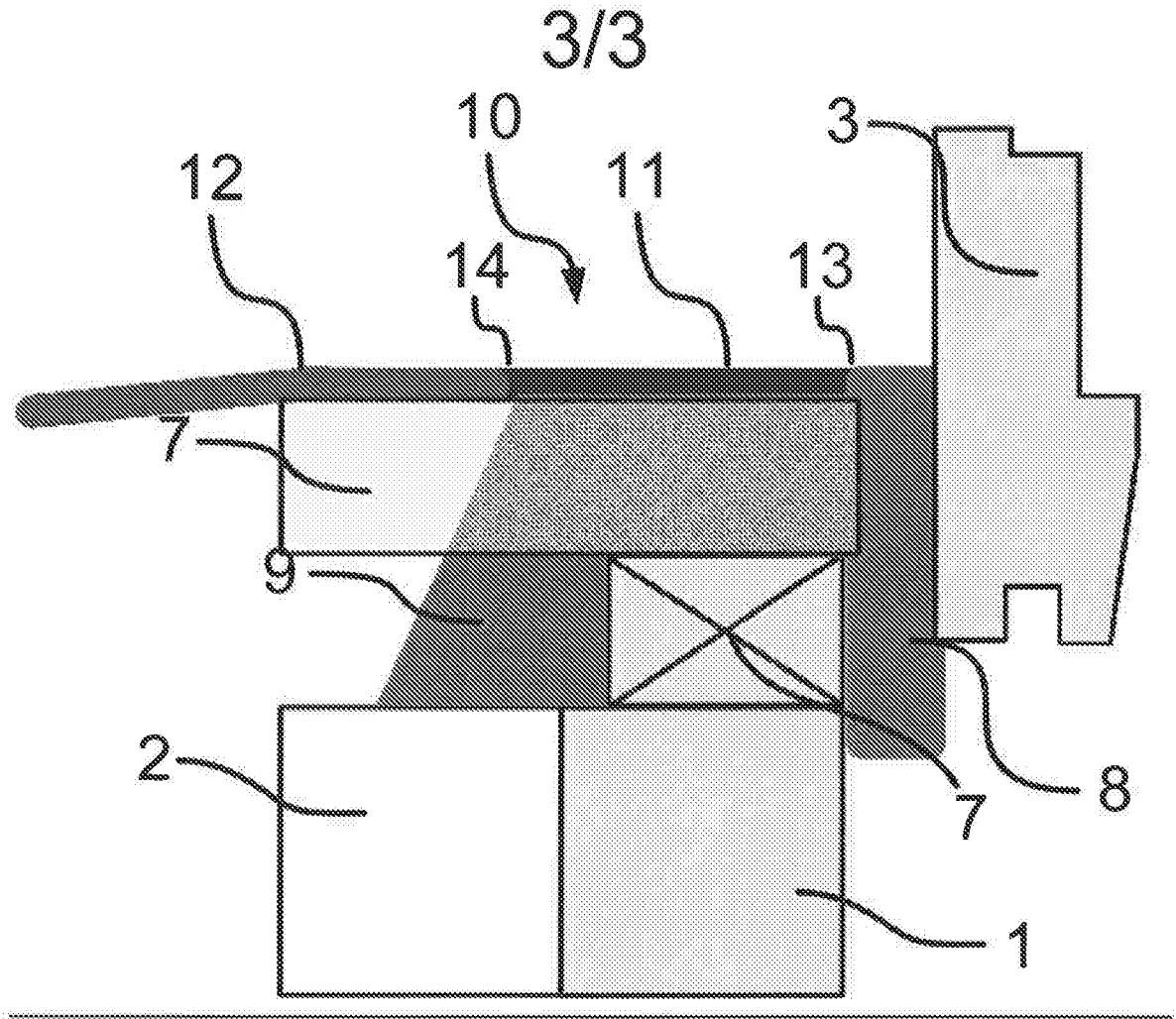

Fig. 3

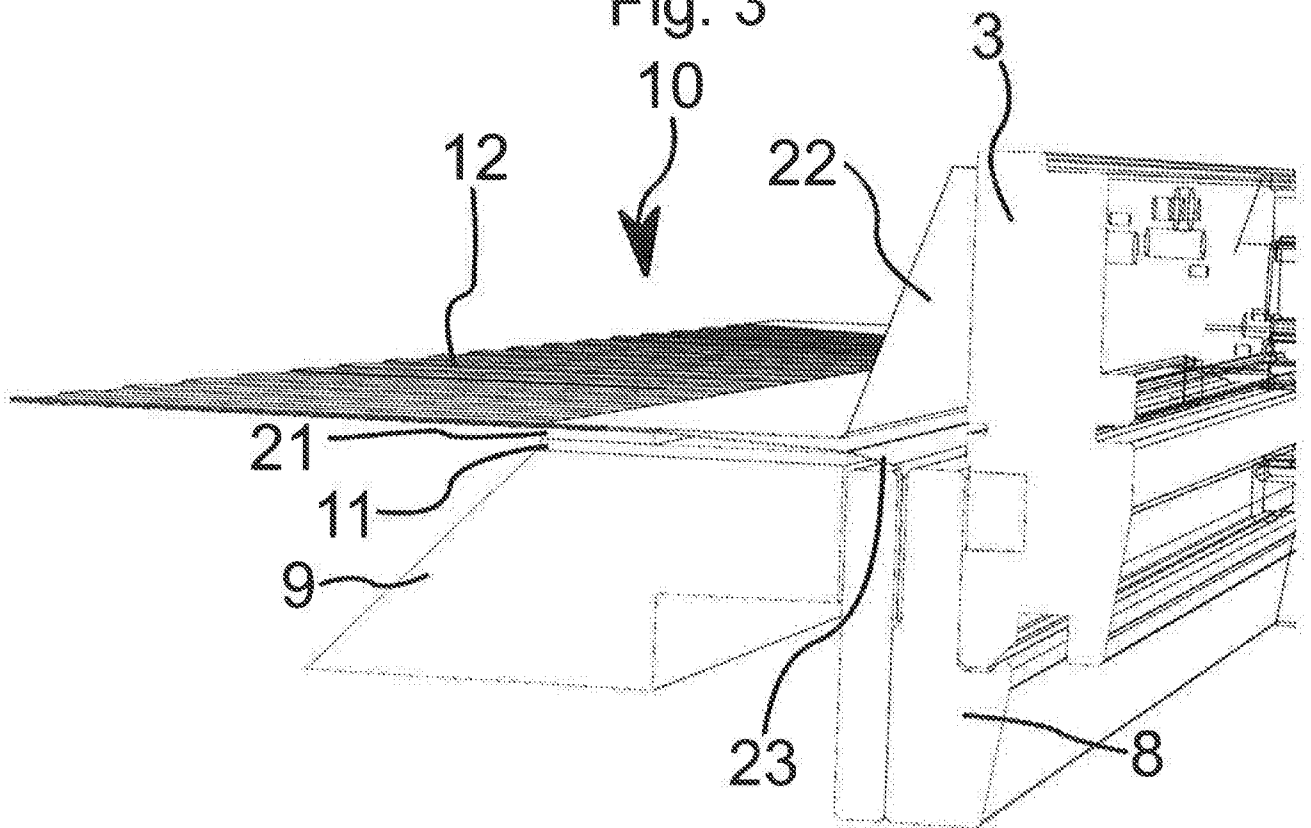

Fig. 4

SEARCH REPORT - PATENT		Application No. PA 2016 70961
1. <input type="checkbox"/> Certain claims were found unsearchable (See Box No. I).		
2. <input type="checkbox"/> Unity of invention is lacking prior to search (See Box No. II).		
A. CLASSIFICATION OF SUBJECT MATTER E 04 D 13/147 (2006.01); E 04 D 13/03 (2006.01) According to International Patent Classification (IPC) or to both national classification and IPC		
B. FIELDS SEARCHED		
PCT-minimum documentation searched (classification system followed by classification symbols) CPC: E04D, E04B, E06B, E04F, E05Y; IPC: E04D, E04B, E06B.		
Documentation searched other than PCT-minimum documentation DK, NO, SE, FI: IPC-classes as above.		
Electronic database consulted during the search (name of database and, where practicable, search terms used) EPODOC, WPI, FULL TEXT: ENGLISH, GERMAN, FRENCH		
C. DOCUMENTS CONSIDERED TO BE RELEVANT		
Category*	Citation of document, with indication, where appropriate, of the relevant passages	Relevant for claim No.
X; A	EP 2284329 A2 (FAKRO PP SPOLKA Z O.O.) 2011.02.16, see sections [0001], [0010] and [0020]-[0022]; claims 1 and 5 and figures 1-4.	1-4 and 6-8; 5 and 9-10
A	EP 2508690 A1 (FAKRO PP SPOLKA Z O.O.) 2012.10.10, see sections [0001], [0011], [0012], [0014], [0018], [0020] and [0022]; claims 1-3 and figures 1-4.	1-10
A	EP 0874101 A1 (MONARFLEX A/S) 1998.10.28, see column 4, line 43 to column 5, line 4; column 8, lines 38-46; column 10, lines 10-17; column 11, lines 52-57; column 18, lines 1-3 and lines 10-32 and figures 1-3 and 10-16.	1-10
A	EP 0994992 B1 (VKR HOLDING A/S) 2002.10.30, see section [0010] and figures 1-3.	1-10
A	GB 2388399 B (VKR HOLDING A/S) 2004.10.06, see page 27, lines 2-13 and figures 18-19.	1-10
<input type="checkbox"/> Further documents are listed in the continuation of Box C.		
*	Special categories of cited documents:	"P" Document published prior to the filing date but later than the priority date claimed.
"A"	Document defining the general state of the art which is not considered to be of particular relevance.	"T" Document not in conflict with the application but cited to understand the principle or theory underlying the invention.
"D"	Document cited in the application.	"X" Document of particular relevance; the claimed invention cannot be considered novel or cannot be considered to involve an inventive step when the document is taken alone.
"E"	Earlier application or patent but published on or after the filing date.	"Y" Document of particular relevance; the claimed invention cannot be considered to involve an inventive step when the document is combined with one or more other such documents, such combination being obvious to a person skilled in the art.
"L"	Document which may throw doubt on priority claim(s) or which is cited to establish the publication date of another citation or other special reason (as specified).	"&" Document member of the same patent family.
"O"	Document referring to an oral disclosure, use, exhibition or other means.	
Danish Patent and Trademark Office Helgeshøj Allé 81 DK-2630 Taastrup Denmark		Date of completion of the search report 19 June 2017
Telephone No. +45 4350 8000 Facsimile No. +45 4350 8001		Authorized officer Henrik Mensing Telephone No. +45 4350 8547

SEARCH REPORT - PATENT		Application No. PA 2016 70961
C (Continuation). DOCUMENTS CONSIDERED TO BE RELEVANT		
Category*	Citation of document, with indication, where appropriate, of the relevant passages	Relevant for claim No.

Box No. I Observations where certain claims were found unsearchable

This search report has not been established in respect of certain claims for the following reasons:

1. Claims Nos.:

because they relate to subject matter not required to be searched, namely:

2. Claims Nos.:

because they relate to parts of the patent application that do not comply with the prescribed requirements to such an extent that no meaningful search can be carried out, specifically:

3. Claims Nos.:

because of other matters.

Box No. II Observations where unity of invention is lacking prior to the search

The Danish Patent and Trademark Office found multiple inventions in this patent application, as follows:

SUPPLEMENTAL BOX

Continuation of Box [.]