

(12) UK Patent Application (19) GB (11) 2 115 711 A

(21) Application No **8301553**
(22) Date of filing **20 Jan 1983**
(30) Priority data
(31) **8202498**
(32) **27 Jan 1982**
(33) **United Kingdom (GB)**
(43) Application published
14 Sep 1983

(51) INT CL³
B01F 13/10 7/08 15/02
15/06
(52) Domestic classification
B1C 102 409 502 506
624 631 652 681 PA
U1S 1253 1539 1767 B1C
(56) Documents cited
GB 1507430
GB 1498349
GB 1409770

(58) Field of search
B1C

(71) Applicant
Ben Travis,
Lingdale, Greenfields
Lane, Rowton, Near
Chester, Cheshire

(72) Inventor
Ben Travis

(74) Agent and/or Address for
Service
Geoffrey Owen and
Company,
76 Lower Bridge Street,
Chester CH1 1RU

(54) **A highway asphalt and coated
macadam recycling machine**

(57) **A recycling machine for highway
asphalt and macadam has a trough-
like container 14 for receiving
reclaimed material from a reception**

hopper 26. The material entering the container is broken up, mixed and conveyed to a discharge end of the container by one or more pluralities of generally helical paddle arrays 25. During its passage along the container 14, the material is subjected to heating by means of a plurality of gas burners 32 which are directed against the underside of the trough 14 and by means of a plurality of radiant heaters 36 disposed above the trough. Neither of the latter heating arrangements subjects the contents of the container to naked flame.

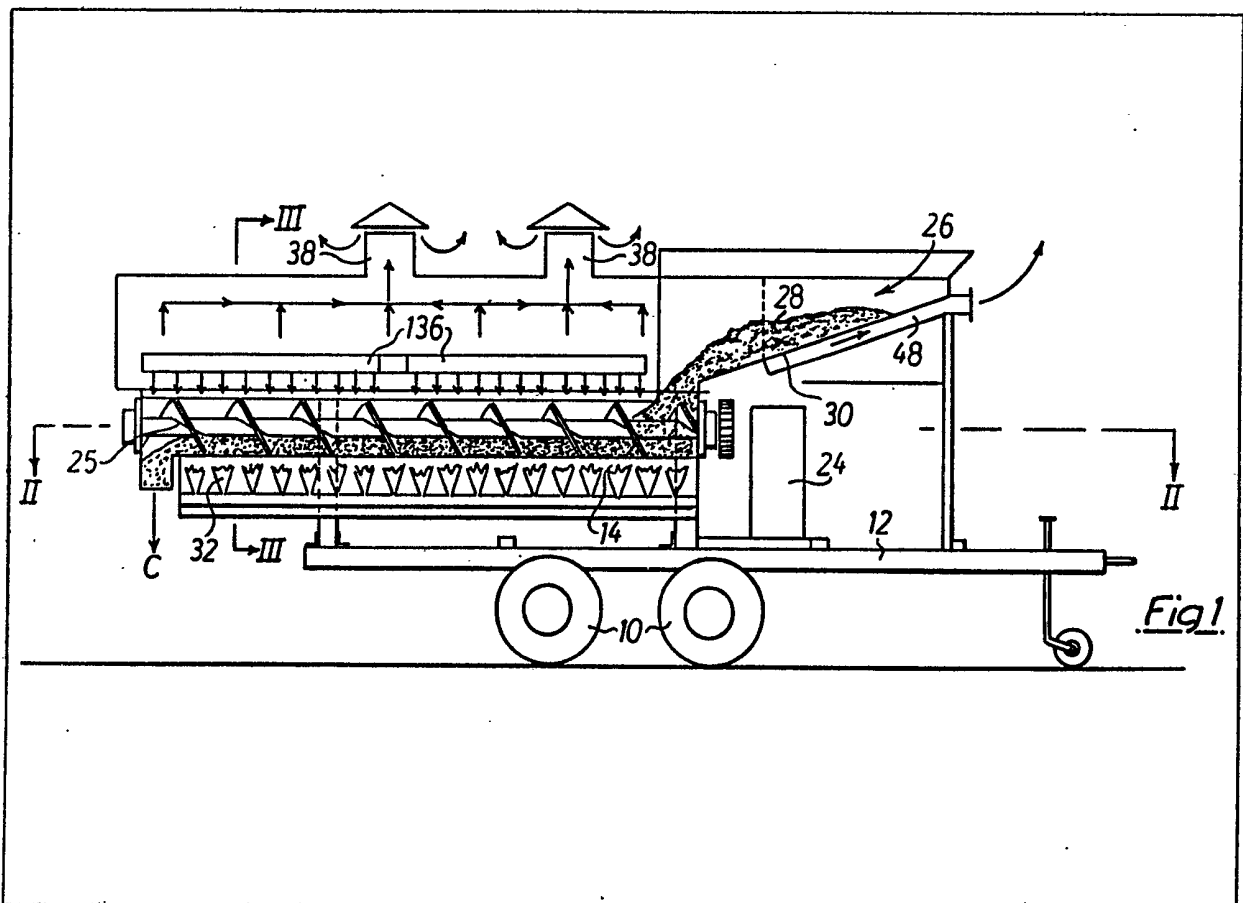

GB 2 115 711 A

This print takes account of replacement documents later filed to enable the application to comply with the formal requirements of the Patents Rules 1982.

The drawings originally filed were informal and the print here reproduced is taken from a later filed formal copy.

1/2

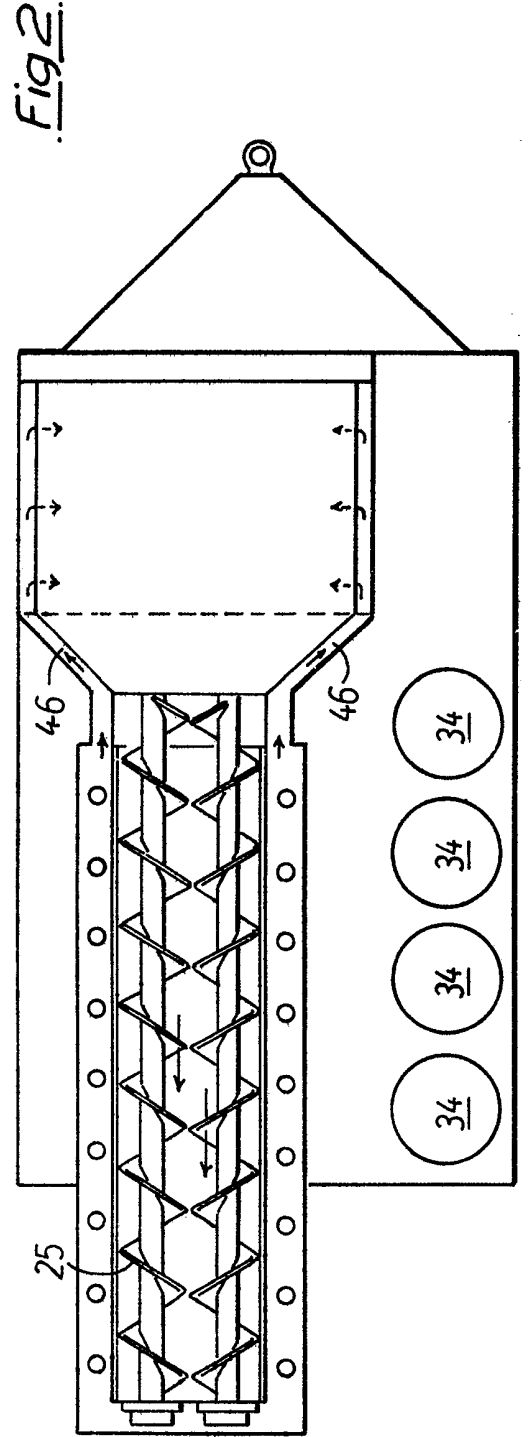
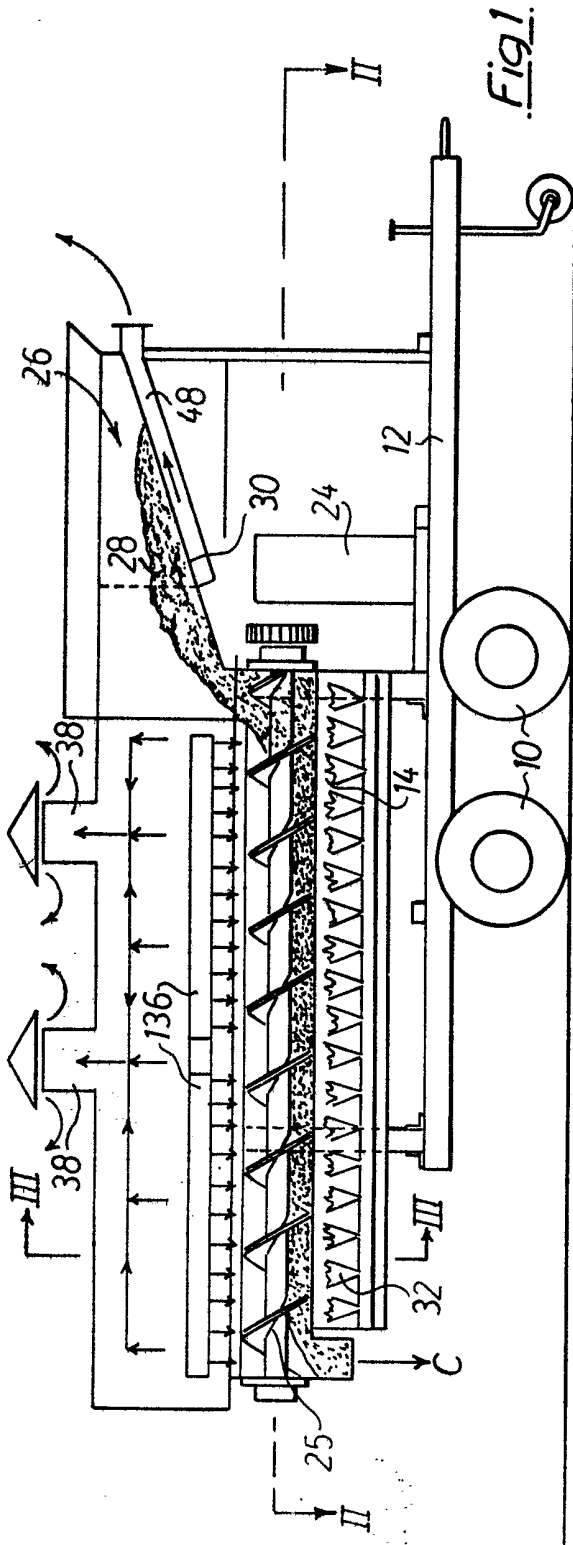

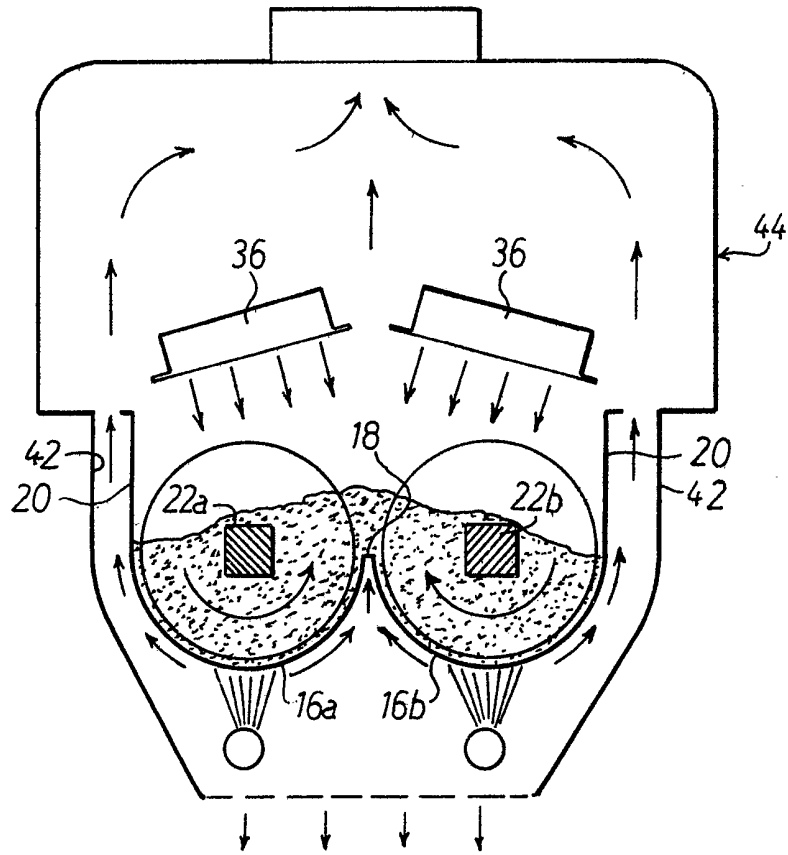

Fig 3.

SPECIFICATION

A highway asphalt and coated macadam recycling machine

5 The present invention is concerned with machines for enabling highway asphalt and coated macadam to be recycled.

10 During the past few years Highway Surveyors have been exploring alternatives to coated macadam and asphalt made from new materials, i.e. virgin stone and new bitumin or asphalt; some plants in Europe and America have been either modified or specifically designed to utilise various percentages of scarifyings or old macadam or asphalt. These plants invariably have taken the form of twin drum dryer/mixers handling varying percentages of used asphalt scarifying, generally not more than 60/70%. The reason why 100% re-claimed material could not be used in these installations was due to the material having to pass through a naked flame resulting in the emission of blue smoke and an attendant fire risk. This problem was overcome in the known machines by feeding into the drum virgin stone which was super-heated and then allowed to mix with the re-claimed material at about the half-way point of the rotating drum mixer, thus avoiding contact between the flame and the re-claimed material. Therefore by using that type of plant it was found to be virtually impossible to re-cycle 100% re-claimed material.

15 It is a principal objective of the present invention to provide a more effective means of recycling re-claimed asphalt and/or macadam which enables a greater proportion of re-claimed material to be used, without losing any of the advantages of the known drum method.

20 In accordance with the present invention, there is provided a recycling machine for highway asphalt and macadam comprising a container for receiving re-claimed asphalt and/or macadam material to be recycled, means in the container for breaking up oversized pieces of said material, mixing said material and conveying same to a discharge end of the container, and a means for heating said material in the container without subjecting the material to naked flame.

25 Preferably, the container comprises an upwardly open, elongate trough.

30 The heating means can include a plurality of gas or oil burners disposed beneath the trough for directly heating the underside of the trough base.

35 The heating means can also include one or more radiant heaters disposed above the trough for heating material in the trough from above.

40 Preferably, said means in the container for breaking up, mixing and conveying the material comprises a plurality of paddles carried by a rotating or angularly reciprocating shaft.

45 One embodiment has a pair of said rotating or reciprocating shafts which contrarotate, each said shaft carrying its own plurality of paddles.

50 The invention is described further hereinafter, by way of example only, with reference to the accompanying drawings, wherein:

55 Fig. 1 is a diagrammatic sectional side elevation of one embodiment of a machine in accordance with the present invention;

60 Fig. 2 is a diagrammatic sectional plan view of the machine of Fig. 1, taken on the line II—II; and

65 Fig. 3 is a diagrammatic sectional end elevation of the machine of Fig. 1, taken on the line III—III.

70 The embodiment shown by way of illustration in the drawings is designed for use as a mobile recycling unit which can be towed or pushed on its own wheels 10 to the site where there is a demand for asphalt and/or macadam to be laid. Other embodiments could, however, equally well be designed for operation at a fixed site in which case the wheels 10 would not be needed.

75 The unit has a rigid chassis 12 carrying an open topped trough container 14 formed by a pair of elongate tubs 16a, 16b of generally U-shaped section which extend longitudinally of the machine in side by side relationship, as best seen in Fig. 3. The tubs 16a, 16b are interconnected along their adjacent side edges as shown at 18, the opposite sides of the tubs being continued upwardly as indicated at 20 to define the side walls of the trough. Disposed on the longitudinal axis of each tub 16a, 16b is a respective shaft 22a, 22b, the latter shafts being adapted to be contrarotated as indicated by the arrows A in Fig. 3, by means of a diesel engine 24 and spur gear arrangement (not shown in detail). Both shafts 22a, 22b carry a plurality of paddles 25 (not shown in detail) which are configured for thoroughly breaking up and mixing particular material introduced into the trough and for gradually conveying such material towards a discharge end (left-hand end in Fig. 1) of the machine, as described further below.

80 The input end of the machine (right-hand end as viewed in Fig. 1) includes a reception hopper or hoppers 26 having a sloping base 30 for introducing particulate material 28 fed thereto into the upstream end of the mixing trough 14 as indicated by arrow B in Fig. 1.

85 Disposed longitudinally beneath the trough 14 is a base heater which in this embodiment comprises a plurality of gas burner jets 32 fed with propane or butane gas from cylinders 34 stored at one side of the chassis 12, as shown in Fig. 2. The burners 32 could equally well be oil fired or electric in other embodiments. As shown in the drawings, the burners play directly on the base of the trough 14 for assisting in heating the contents to the desired temperature. Additional heating is supplied by a plurality of radiant heaters 36 disposed above the trough 14 as shown in Figs. 1 and 3. The radiant heaters can also be gas powered or they could be oil or electric. It will be noted that in the case of both the base heaters and the upper radiant heaters the contents of the trough are not subjected to naked flame, the heating being effected principally by way of hot air.

90 A portion of the heat from the base burners escapes to the atmosphere through upper exhaust cowlings via further side passages 46 (Fig. 2) to a

plenum chamber 48 beneath the reception chamber 26 for the pre-heating of the chamber contents.

5 In use, re-claimed asphalt and/or macadam removed from, for example, a section of highway to be resurfaced is introduced into the reception hopper 26 (together with binder material as necessary), where it is subjected to pre-heating by the hot exhaust gas in the plenum 48. The pre-heated asphalt/macadam is passed under gravity (or in some cases by a vibratory feeder) into the upstream end of the trough 14 where it comes under the disintegrating, mixing and conveying action of the paddles carried by the shafts 22a, 22b. Although shown diagrammatically in the drawings as a continuous helical conveyor, the paddles 25 are preferably parts of a discontinuous helix whereby the individual paddles act as teeth or prongs which continually subject the mass of asphalt/macadam to a breaking up and mixing action while at the same time gradually conveying same towards the discharge end of the trough. During this time, the asphalt/macadam is subjected to the heating effect of the base heaters 32 and the radiant heaters 36 whereby its temperature is raised to approximately 75°C, or above.

30 The reconstituted asphalt/macadam which discharges out of the downstream end of the trough (arrow C) can be applied directly to the road to be resurfaced or can be collected and transported to the re-surfacing location. In the case of a mobile machine, this could therefore be towed around with the road repairing team who could excavate the old asphaltic material and then by feeding the material into the recycling apparatus, adding any new binder as necessary, could have the availability of hot patching material to be laid immediately. This would considerably ease and improve the quality of the patching operation instead of having to rely on asphalt of storage grade, which does not usually provide good results. By the use, of the present apparatus particles constituted by 100% of re-claimed material (disregarding any necessary binder) can be re-cycled.

50 Although the trough shown in the illustrated embodiment has two parallel tub components, it is not necessary for the trough to have this configuration and a single tube and single shaft or plural tubs with plural shafts could equally well be used, or the system could be Batch instead of continuous.

55 In other embodiments, the or each set of paddles could perform an oscillatory action (say through 200° angular movement) as compared with the fully rotary motion of the presently illustrated machine. In any event, the paddles must be capable of breaking down any oversized lumps of re-claimed material, of thoroughly mixing the resulting particles and of conveying such particles to the discharge end of the trough.

65 In addition to the re-claimed asphalt and/or macadam material supplied to the machine, a proportion of virgin aggregate can also be introduced as appropriate for the final product. Means can be provided for introducing additional bitumen, binder or rejuvenating agents, as necessary.

70 CLAIMS

75 1. A recycling machine for highway asphalt and macadam comprising a container for receiving reclaimed asphalt and/or macadam material to be recycled, means in the container for breaking up oversized pieces of said material, mixing said material and conveying same to a discharge end of the container, and a means for heating said material in the container without subjecting the material to naked flame.

80 2. A recycling machine as claimed in claim 1 wherein the container comprises an upwardly open elongate trough.

85 3. A recycling machine as claimed in claim 2 wherein the heating means includes a plurality of gas or oil burners disposed beneath the trough for directly heating the underside at the trough base.

90 4. A recycling machine as claimed in claim 3 wherein the heating means also includes one or more radiant heaters disposed above the trough for heating material in the trough from above.

95 5. A recycling machine as claimed in claim 2, 3 or 4 wherein said means in the container for breaking up, mixing and conveying the material comprises a plurality of paddles carried by a rotating or angularly reciprocating shaft.

100 6. A recycling machine as claimed in claim 5 wherein the container comprises a pair of parallel, side by side, open-topped tubs, each having its own plurality of paddles carried by a rotating or reciprocating shaft.

105 7. A recycling machine as claimed in claim 5 or 6 having a pair of said rotating or angularly reciprocating shafts which contra-rotate, each said shaft carrying its own plurality of paddles.

110 8. A recycling machine as claimed in claim 5, 6 or 7 wherein the shaft (or shafts) is driven by an engine via a gearbox.

115 9. A recycling machine as claimed in any of claims 1 to 8 further including a reception hopper for re-claimed material, the hopper being adapted to feed the latter material into the inlet end of the container.

120 10. A recycling machine as claimed in claim 9 including a vibratory feeding means for assisting flow of material from the hopper into the container.

125 11. A recycling machine as claimed in claim 9 or 10 including a plenum chamber adjacent the reception hopper, the plenum being arranged to receive hot exhaust gases from the heating means for pre-heating material prior to its entry into the container.

12. A recycling machine as claimed in any of
claims 1 to 11 having wheels to make it mobile.
13. A recycling machine for highway asphalt

5 and macadam, substantially as hereinbefore
described with reference to and as illustrated in
the accompanying drawings.

Printed for Her Majesty's Stationery Office by the Courier Press, Leamington Spa, 1983. Published by the Patent Office
25 Southampton Buildings, London, WC2A 1AY, from which copies may be obtained.