



- (51) International Patent Classification:  
*B29C 41/36* (2006.01) *B41J 2/21* (2006.01)
- (21) International Application Number:  
PCT/EP2012/000025
- (22) International Filing Date:  
4 January 2012 (04.01.2012)
- (25) Filing Language: English
- (26) Publication Language: English
- (30) Priority Data:  
11000072.6 6 January 2011 (06.01.2011) EP
- (71) Applicant (for all designated States except US): **LUXEX-CEL HOLDING BV.** [NL/NL]; Veerweg 34, NL-4471 NC Wolphaartsdijk (NL).
- (72) Inventors; and
- (75) Inventors/Applicants (for US only): **BLESSING, Kurt** [DE/DE]; Wauerthang 15, 58507 Lüdenscheid (DE). **VAN DE VRIE, Richard** [NL/NL]; Veerweg 34, NL-4471 NC Wolphaartsdijk (NL).
- (74) Agents: **LOOCK, Jan Pieter** et al.; Kutzenberger & Wolff, Patentanwaltssozietät, Theodor-Heuss-Ring 23, 50668 Köln (DE).
- (81) Designated States (unless otherwise indicated, for every kind of national protection available): AE, AG, AL, AM, AO, AT, AU, AZ, BA, BB, BG, BH, BR, BW, BY, BZ, CA, CH, CL, CN, CO, CR, CU, CZ, DE, DK, DM, DO, DZ, EC, EE, EG, ES, FI, GB, GD, GE, GH, GM, GT, HN, HR, HU, ID, IL, IN, IS, JP, KE, KG, KM, KN, KP, KR, KZ, LA, LC, LK, LR, LS, LT, LU, LY, MA, MD, ME, MG, MK, MN, MW, MX, MY, MZ, NA, NG, NI, NO, NZ, OM, PE, PG, PH, PL, PT, QA, RO, RS, RU, RW, SC, SD, SE, SG, SK, SL, SM, ST, SV, SY, TH, TJ, TM, TN, TR, TT, TZ, UA, UG, US, UZ, VC, VN, ZA, ZM, ZW.
- (84) Designated States (unless otherwise indicated, for every kind of regional protection available): ARIPO (BW, GH, GM, KE, LR, LS, MW, MZ, NA, RW, SD, SL, SZ, TZ, UG, ZM, ZW), Eurasian (AM, AZ, BY, KG, KZ, MD, RU, TJ, TM), European (AL, AT, BE, BG, CH, CY, CZ, DE, DK, EE, ES, FI, FR, GB, GR, HR, HU, IE, IS, IT, LT, LU, LV, MC, MK, MT, NL, NO, PL, PT, RO, RS, SE, SI, SK, SM, TR), OAPI (BF, BJ, CF, CG, CI, CM, GA, GN, GQ, GW, ML, MR, NE, SN, TD, TG).

[Continued on next page]

(54) Title: PRINT HEAD, UPGRADE KIT FOR A CONVENTIONAL INKJET PRINTER, PRINTER AND METHOD FOR PRINTING OPTICAL STRUCTURES

Fig. 1

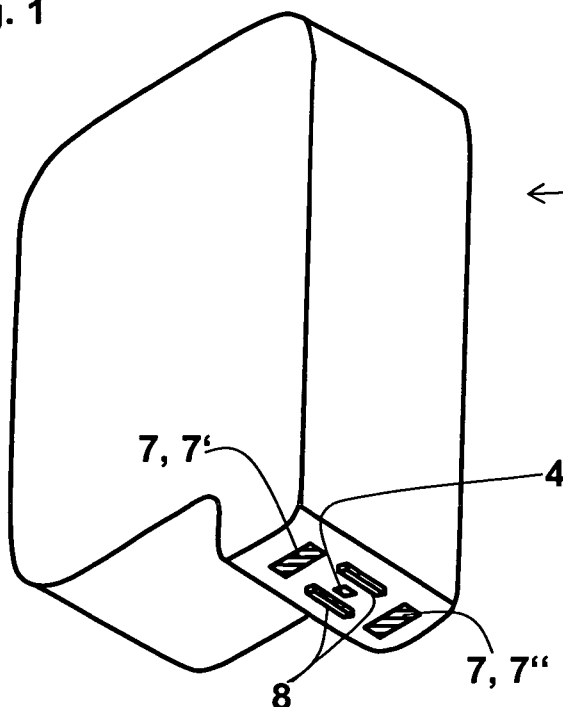

(57) Abstract: The invention relates to a print head for printing optical structures on a substrate comprising an ejection device for ejecting at least one droplet of a printing ink towards the substrate in order to build up the optical structure, wherein the print head comprises a measurement means for contactless measuring at least one physical parameter of the at least one deposited droplet.

**Published:**

— *with international search report (Art. 21(3))*

**DESCRIPTION****Print head, upgrade kit for a conventional inkjet printer, printer  
and method for printing optical structures****BACKGROUND**

The present invention relates to a print head for printing optical structures on a substrate comprising an ejection device for ejecting at least one droplet of a printing ink towards the substrate in order to build up the optical structure.

It is common knowledge that products provided with optical structures can be manufactured in a comparably time-saving and inexpensive way by printing the optical structures directly on an appropriate substrate. Suchlike imprinted optical structures comprise lenses, mirrors or retroreflectors, for instance. The substrate can be made of synthetic material or glass. Furthermore, it is well known to cure the imprinted material by using light irradiation for reducing the overall printing time.

For Example, PCT patent application WO 2010 / 091 888 A1 discloses a method for producing optical lenses from a moldable transparent material by depositing the material on a substrate in a layer that is subsequently cured by a laser or by UV irradiation. The transparent material is deposited on the substrate by a conventional printing-on-demand printer, for instance.

In order to provide high quality optical structures with certain optical effects, the three dimensional geometries and the surface contours of the optical structures have to be precisely designed according to a given pattern. Even the slightest deviation in the intended geometry of the optical structures results in significant optical errors. Consequently, the droplets have to be positioned onto the substrate with high accuracy and curing has to be performed depending on the present flow behavior of the printing ink.

This is very difficult because the behavior of the just at the moment deposited and still uncured droplets strongly depends on many factors, like material and surface conditions of the substrate, composition of the printing ink, atmospheric pressure, temperature, air moisture, orientation between the printer and the gravitational field and the like.

Disadvantageously, it is not possible to take into account all of these factors previously.

## SUMMARY

An object of the present invention is to provide a print head, an upgrade kit for a conventional inkjet printer, an inkjet printer and a method for printing optical structures providing the printing of reproducible high quality optical structures.

The object of the present invention is achieved by a print head for printing optical structures on a substrate comprising an ejection device for ejecting at least one droplet of printing ink towards the substrate in order to build up the optical structure, wherein the print head comprises a measurement means for contactless measuring at least a physical parameter of the at least one deposited droplet.

According to the present invention, it is thereby advantageously possible to provide a print head which enables the verification of the imprinted droplets and/or of the formed optical structure by measuring the at least one physical parameter. Consequently, a feedback is generated in time by the print head which is based on the actual and real physical conditions of the deposited droplets. Potential deviations e.g. from the desired geometry are being identified by the print head in real-time and if necessary can be rectified in further printing and/or curing steps. In this way, all potential environmental disturbances are automatically taken into account. Furthermore, a real-time control of the printing process is possible which reduces the number of rejections and the involved costs. Preferably, a the contactless measurement is accomplished before, during and/or shortly after depositing a further droplet of printing ink. In particular, the print head is configured for ejecting further droplets of printing ink in dependence upon the recently measured physical parameters, so that the detected deviation from the desired geometry can be compensated.

Preferably, geometric parameters, like the thickness and/or the surface conditions of the at least one deposited droplet and/or of the layer of multiple deposited droplets are determined, wherein particularly preferably those geometric parameters of the at least one deposited droplets are measured which directly influences the optical characteristics of the optical structure. Preferably, also optical characteristics, like the grade of transmission, the grade of reflection and/or the coloring of the deposited droplet and/or the layer of multiple deposited droplets are determined. It is conceivable that not only geometric and/or optical parameters of the at least one deposited droplet is measured, but also geometric and/or optical parameters of a subsection or of the whole optical structure is measured by the measurement means in order to evaluate the overall design. Preferably, the measurement means are provided near the ejection device on a moving part of the printing head. Optical structures in the sense of the present invention in particular comprise micro lenses, Fresnel

structures, optical prisms and the like, which are made of multiple droplets of printing ink deposited by the printing head. The printing ink preferably comprises a transparent material. In order to build up the optical structure, the droplets have to be arranged side by side and one above the other, preferably partly overlapping each other, so that the optical structure mainly forms a 3D-structure which optically influences light passing the optical structure and/or the substrate.

According to a preferred embodiment of the present invention, the measurement means is configured for layer thickness measurements and/or for distance measurements. Preferably, the measurement means are provided for determining the distance between the measurement means and the at least one deposited droplet. This method allows a comparatively simple method of determining the geometric parameters, like thickness and/or surface contour of the imprinted printing ink. It is conceivable that the measurement means performs reference measurements in between. In the reference measurements the measurement means measures the distance between the substrate and the measurement means, so that the thickness of the layer of deposited droplets can simply be calculated from the mathematical difference between the measured distance between the substrate and the measurement means (reference measurement) and the distance between the surface of the layer of deposited droplets and the measurement means. Preferably, the distance is measured from at least two different locations at the print head in order to increase accuracy. The optical characteristics, like grade of transmission, grade of reflection and/or coloring are determined e.g. by comparing the spectrum of the light projected towards the deposited droplets with the spectrum of the reflected light. Alternatively, the luminous power of the reflected light is compared to the luminous power of the light radiated by the light source.

Preferably, the measurement means is configured for triangulation measurements. The wording triangulation measurements in the sense of the present invention principally comprises a process of determining the location of a point by measuring angles to it from known points (at the print head) at either ends of a fixed baseline, rather than measuring the distance to the point directly. Particularly, the print head is configured for performing LASER-triangulation which is a comparatively precise and reliable method for determining geometry parameters. But also other contactless measurement methods e.g. based on ultrasonic waves or other light source can be used for distance measurements and especially for triangulation measurements in the sense of the present invention. For using LASER-triangulation measurements, the measurement means comprises at least one LASER source for projecting a laser spot onto the at least one deposited droplet and at least one receiving means, preferably a CCD- (Charge Coupled Device) camera for receiving the laser light of the at least one LASER source after reflection at the deposited droplet. Furthermore, an

evaluation unit is provided for calculating the geometric parameter from the position of the laser spot on the deposited droplet and from the known distance between the LASER source and the receiving means at the print head (in particular the baseline is parallel to the substrate). In this manner, the angle between the light beam sent out by the LASER and the reflected corresponding light beam received by the CCD-camera is measured. From this the distance to the surface of the deposited droplet and in particular the thickness of the layer of printing ink on the substrate can be calculated.

According to another preferred embodiment, the measurement means is configured for optical interference measurements. The measurement means comprises e.g. an interferometer which is capable of performing precision measurements of the thickness and/or the surface contour of the layer of deposited droplets by using Interferometry. According to this technique, two or more light waves are analyzed by their superposition, so that slight phase shifts in the light waves can be detected. Conceivable, a light wave reflected by the surface of the layer of deposited droplets is superposed with a reference light wave in order to determine the thickness of the layer, for instance.

According to another preferred embodiment of the present invention, the print head comprises a curing device for curing the at least one deposited droplet, wherein preferably the curing device comprises at least one UV-LED (ultraviolet emitting light-emitting diode). In order to build up the optical structure, the droplets have to be arranged side by side and one above the other, preferably partly overlapping each other, so that the optical structure mainly forms a 3D-structure which optically influences light passing the optical structure and/or the substrate. Consequently, a new droplet deposited on the 3D structures has timely to be cured to avoid that the new deposited droplet flows off the 3D structure. This aim can be achieved by using the UV LED as the curing device, because on the one hand the switching times of UV LED's are comparably short and on the other hand UV LED's provide high radiation power. The curing device is particularly configured for curing the at least one deposited droplet and/or the optical structure depending on the measured geometric and/or optical parameters. For example, if a desired shape of the optical structure is obtained, the curing device is enabled for final hardening the optical structure. Alternatively, if the measurements show that the shape of the optical structure has to be revised, the deposited droplets get only partially hardened, so that further droplets can be deposited merging with the partially hardened droplets in order to achieve the desired geometry.

Particularly, the print head is movable relative to the substrate, wherein the print head is movable in parallel to a plane of the substrate to deposit droplets of the printing ink at a certain position on the substrate and/or wherein the print head is rotatable relatively to the

substrate to adjust the ejection direction of the droplets. It is herewith advantageously possible that the position of the print head relatively to the substrate and therefore also the positions of the deposited droplets relatively to the substrate are software-controlled. Preferably, the ejection device is rotatable supported around a pivot axle extending perpendicular to the conveying direction and parallel to the plane of the substrate, wherein preferably the print head comprises a stepper motor swiveling the ejection device about the pivot axle. It is herewith advantageously possible to adjust the position of the deposited droplet on the substrate relatively to the conveying direction. Thus, multiple droplets can be deposited on the same position of the substrate one above the other, while the substrate continually moves along the conveying direction. Preferably, the movement and in particular the rotation of the ejection is performed depending on the measured geometric and/or optical parameters. It is herewith advantageously possible that inaccuracies in the shape of the optical structure can be corrected by correspondingly adjusting the ejection direction and ejecting further droplets onto the still incorrect optical structure. Another advantage of this approach is that by adjusting the ejection direction the shape of the deposited droplet on the substrate can be influenced, as the symmetry or asymmetry of the deposited droplet depends on the angle between the ejection direction and the plane of the substrate.

According to another preferred embodiment of the present invention, it is preferred that the curing device comprises at least two UV-LED's emitting light of different wavelength ranges, wherein the at least two UV-LED's are controlled depending on the measured geometric and/or optical parameters. It is herewith advantageously possible that one of the two UV-LED's is provided for only partially hardening the deposited droplet, wherein the other of the two UV-LED's is provided for final hardening of the optical structure not until the measurements show that the geometry and/or optic of the optical structure is sufficiently accurate. Furthermore, the curing status of the deposited droplets can be determined by the measurement means, so that a further curing step is performed when the measurements show that the printing ink is so far not completely hardened. By this means, the overall curing time can be optimized. The at least two UV-LED's are provided in such a manner that the light cones emitted by each of the at least two UV-LED's overlap each other in the area of the at least one deposited droplet. Thereby, it is advantageously possible to increase the energy deposition in the area of the deposit printing ink to be cured and consequently to decrease the overall curing time.

Preferably, a first UV-LED of the at least two UV-LED's is capable of emitting ultraviolet light of a first wavelength range and a second UV-LED of the at least two UV-LED's is capable of emitting ultraviolet light of a second wavelength range, wherein the second wavelength range differs at least partially from the first wavelength. Preferably, the print head comprises at

least a first and a second ejection device, wherein the first ejection device is capable of ejecting at least one droplet of a first printing ink and wherein the second ejection device is capable of ejecting at least one droplet of a second printing ink, wherein the first printing ink is curable by ultraviolet light of the first wavelength range and wherein the second printing ink is curable by ultraviolet light of the second wavelength range. It is hereby advantageously possible to cure different deposited droplets at different times which enable fast printing of comparatively complex optical structures and to efficiently rectify incorrect optical structures in dependence of the measurements of the geometric and optical parameters. It is even conceivable that the second printing ink differs from the first printing ink in at least one physical parameter, wherein the physical parameters preferably comprises curing time, curing temperature, curing wavelength, viscosity, transmittance and/or optical transparency. It is herewith advantageously possible to print certain portions of the optical structures providing certain optical effects compared to other portions of the optical structures, e.g. by printing the certain portions with printing ink which provides a certain optical transparency.

Another object of the present invention is an upgrade kit for a conventional inkjet printer for printing optical structures on a substrate comprising a print head in accordance with the present invention. Thereby, it is advantageously possible that the print head according to the present invention can be applied in a conventional inkjet printer in order to upgrade the inkjet printer for optic printing applications. For example, upgrading the conventional inkjet printer comprises a step of removing the conventional inkjet printer head of the conventional inkjet printer and replacing it by the print head according to one of the claims 1 to 13. In addition, the firmware and/or the software drivers of the inkjet printer are preferably updated in a further step.

Another object of the present invention is a printer, preferably an inkjet printer, comprising a print head in accordance with the present invention.

Another object of the present invention is a method for printing optical structures on a substrate by using a print head, in particular according to the present invention, comprising steps of providing the substrate and ejecting at least one droplet of a printing ink towards the substrate in order to build up the optical structure, wherein a further step of contactless measuring at least a physical parameter of the at least one deposited droplet is performed.

It is herewith advantageously possible that the physical conditions, in particular the geometric and/or optical conditions, of the imprinted droplets or of a layer of multiple imprinted droplets are verified during the printing procedure, preferably in real-time. In this way, a correction of the surface of the optical structure can be performed in further printing steps when deviations from the desired shape are measured, for instance.



According to a preferred embodiment of the present invention, the at least one physical parameter is measured in real-time measurements. That means that measuring the at least one physical parameter is performed before and/or during a further droplet of printing ink is deposited. Preferably, the deposition of the further droplet is performed depending on the measured physical parameter in order to achieve a desired accurate and verified shape of the printed optical structure.

Preferably, the distance between the measurement means and the at least one deposited droplet is determined in the further step. The geometric parameter comprises e.g. thickness and/or surface contour of the deposited droplet. According to a preferred embodiment, also optical parameters, like grade of transmission, grade of reflection and/or coloring of the at least one deposited droplet and/or the optical structure are evaluated in the further step. In particular, the following printing steps are optimized depending on the geometric and/or optical parameters in order to achieve a desired accurate shape of the printed optical structure. Preferably, further steps of depositing droplets of printing ink on the substrate are performed depending on the measured geometric and optical parameters. For example, the printing time, the kind of printing ink, the ejection direction of the droplet, the position of the deposited droplet on the substrate, the quantity of ejected printing ink, the sizes of the droplets, the number of further droplets are determined depending on the measured geometric and optical parameters. It is also calculated where on the substrate further droplets have to be deposited and how much printing ink has to be deposited in order to optimize the shape of the optical structure, for instance. Furthermore, e.g. the required printing speed, curing time and/or orientation of the printing head is determined. It is conceivable that also the kind of printing ink is selected if different printing inks would be available. In particular, the steps of depositing droplets of printing ink and measuring the geometric and optical conditions are repeated iteratively until a satisfactory optical structure is achieved. Preferably, the at least one deposited droplet is cured by using ultraviolet light emitted from at least one UV-LED, wherein the steps of ejecting the at least one droplet, measuring the geometric and optical conditions and curing the at least one deposited droplet are repeated one or more times in order to generate an optimized optical structure.

According to another embodiment of the present invention, it is preferred that triangulation measurements are performed to measure the geometric and/or optical parameters of the at least one deposited droplet and/or of the optical structure. Preferably, LASER-triangulation measurements are performed in the further step, wherein a laser spot is projected onto the at least one deposited droplet by LASER source of the printing head and laser light reflected by the at least one deposited droplet is received by receiving means, preferably a CCD-camera,

of the printing head. For this purpose, the geometric parameter is calculated from the position of the laser spot on the at least one deposited droplet and the known distance between the LASER source and the receiving means at the print head. It is herewith advantageously possible to provide a comparatively exact and reliable control of the printing procedure.

According to another preferred embodiment of the present invention, the method comprises a step of moving and preferably rotating the print head to a certain position relatively to the substrate depending on the measured geometric and optical conditions before ejecting a further droplet. It is herewith advantageously possible to adjust the position of the deposited droplet on the substrate. Thus, multiple droplets can be deposited on the same position of the substrate one above the other, while the substrate continually moves along the conveying direction. Furthermore, inaccuracies in the shape of the optical structure can be corrected by correspondingly adjusting the ejection direction and ejecting further droplets onto the optical structure. Another advantage of this approach is that by adjusting the ejection direction the shape of the deposited droplet on the substrate can be influenced, as the symmetry or asymmetry of the deposited droplet depends on the angle between the ejection direction and the plane of the substrate.

Preferably, the steps of moving the print head, ejecting the at least one droplet and curing the at least one deposited droplet are repeated one or more times in order to generate the optical structure. In a preferred embodiment the print head contains a plurality of different ejecting devices, wherein each ejecting device ejects different and/or equal printing inks and wherein the ejection of the ejecting devices occurs simultaneously and/or subsequently.

According to another embodiment of the present invention, it is preferred that the method comprises a step of printing a visible picture onto the substrate by the print head, preferably before, during or after the optical structure is printed onto the substrate. The printed picture comprises, in particular, a motif, specified optical effects being generated by the optical structure when the motif is observed. In particular, the optical structure is adjusted to the motif in such a way that only the optical appearance of partial areas of the motif is correspondingly modified by the optical structure. The motif can be produced by means of transparent or non-transparent printing ink according to choice. The picture represents, for example, the picture of a landscape, an object, a photo, a lettering or similar. Logos or alphanumeric symbols, which can be used for advertising or information purposes, are also possible as motifs. These symbols can be made detectable either by the optical structure or by corresponding colouring. A light-directing and glare-reducing device can be especially advantageously implemented so that the lower light-directing elements direct incident light

strongly upward in a bundled form, whereas the upper light-directing elements direct incident light into the depth of the room in a flatly bundled form, so that an even distribution of scattered light in the room is generated. Targeted projection of a coloured logo, symbol or writing is also possible. This formation can then be provided, for example, on a corresponding window pane or similar. According to a preferred embodiment of the present invention, it is provided that the substrate comprising the imprinted optical structure and/or the imprinted picture comprises a billboard, a poster, a decorative surface, a cladding element, a facade cladding, a brochure or periodical page, a cover sheet, a picture, a packaging (e.g. a food packaging), a label, a house number, a window image, a screen, a lampshade, a diffusing screen, an adhesive label, a plate, a computer screen and/or similar.

These and other characteristics, features and advantages of the present invention will become apparent from the following detailed description, taken in conjunction with the accompanying drawings, which illustrate, by way of example, the principles of the invention. The description is given for the sake of example only, without limiting the scope of the invention. The reference figures quoted below refer to the attached drawings.

#### BRIEF DESCRIPTION OF THE DRAWINGS

Figures 1 and 2 schematically show a print head according to an exemplary first embodiment of the present invention.

Figure 3 schematically shows a print head according to an exemplary second embodiment of

#### DETAILED DESCRIPTION

The present invention will be described with respect to particular embodiments and with reference to certain drawings but the invention is not limited thereto but only by the claims. The drawings described are only schematic and are non-limiting. In the drawings, the size of some of the elements may be exaggerated and not drawn on scale for illustrative purposes.

Where an indefinite or definite article is used when referring to a singular noun, e.g. "a", "an", "the", this includes a plural of that noun unless something else is specifically stated.

Furthermore, the terms first, second, third and the like in the description and in the claims are used for distinguishing between similar elements and not necessarily for describing a

sequential or chronological order. It is to be understood that the terms so used are interchangeable under appropriate circumstances and that the embodiments of the invention described herein are capable of operation in other sequences than described or illustrated herein.

Figures 1 and 2 schematically show an example a print head 1 according to an exemplary first embodiment of the present invention.

Figure 1 illustrates a print head 1 having an ejecting device 4, measuring means 7 and a curing device 8 at its bottom side. The ejecting device 4 comprises an ejecting nozzle for ejecting droplets of a liquid polymer-based printing ink provided in an inner chamber 12 of the print head 1 (not shown in figure 1). The ejecting device 4 is applicable for ejecting the droplets onto a substrate 3 (not shown in figure 1) in order to build up an optical structure 2 like optical lenses, optical prism and/or Fresnel structures on the substrate 3. The substrate 3 is preferably made of a transparent synthetic film material or a glass plane, wherein the printing ink is transparent ink curable by ultraviolet light. The measuring means 7 is provided for contactless measuring geometric and optical parameters of the deposited droplet 5 or the optical structure 2 build up by the deposited droplets 5. LASER triangulation measurements are used as measuring technique. For this purpose, the measurement means 7 comprise a LASER source 7' and a CCD camera 7'' spaced apart from each other. The nozzle is located between the LASER source 7' and the CCD camera 7''. The LASER source 7' is provided for projecting laser light towards the deposited droplet 5 which is reflected by the surface of the deposited droplets 5 towards the CCD camera 7''. The CCD camera 7'' measures the position and in particular the incidence angle of the reflected laser light. The light path 6 of the laser light is schematically illustrated in figure 2 as a dotted line. The distance between the print head 1 and the surface of the deposited droplet 5 is calculated subsequently from the measured incidence angle of the reflected laser light and the known fixed distance (illustrated as baseline 18 in figure 2) between the LASER source 7' and the CCD camera 7'' on the bottom of the print head 1. The three dimensional surface contour of the deposited droplets 5 and the optical structure 2 can be determined by performing multiple triangulation measurements in different positions of the printing head 1 or under diverse angles. Subsequent printing steps are performed depending on the determined surface contour in order to build up a certain optical structure 2.

The curing device 8 comprises two UV-LED's (ultraviolet emitting light-emitting diode) for curing the deposited droplet 5, wherein the nozzle is located between these two UV-LED's. The steps of depositing droplets of printing ink, at least partially curing the deposited droplet 5 and measuring the surface contour of the optical structure 2 build up by multiple deposited

droplets 5 are repeated iteratively until a desired shape of an optical structure 2 is achieved. Afterwards, a step of finally curing the optical structure 2 is accomplished. The print head 1 fits into a conventional inkjet printer (not shown in figure 1), so that a conventional inkjet printer can be upgraded for printing optical structures 2 simply by replacing the conventional print head by the print head 1 according to the present invention. Preferably, the print head 1 shown in figure 1 is a part of an inkjet printer and/or is a part of an upgrade kit for a conventional inkjet printer.

Figure 2 shows a cross-sectional view of the print head 1 illustrated in figure 1. The print head 1 uses a piezoelectric material 9 in the ink-filled chamber 12 behind the nozzle of the ejecting device 4. When a voltage is applied to the piezoelectric material 9, the piezoelectric material 9 changes its shape (see dotted curve 10), which generate a pressure pulse 11 in the liquid printing ink in the chamber 12 forcing a droplet of the printing ink 4 from the nozzle towards the substrate 3 along the ejection direction 14 (the ejection direction 14 is directed perpendicular to the plane of the substrate 3 in the present example). In the present example, the droplet is deposited onto other previously printed droplets 5 in order to build up the optical structure 2. Subsequently, the UV-LED's are enabled, so that the deposited droplet 5 is at least partially cured due to irradiation with ultraviolet light from the UV-LED's. The light cones of the UV-LED's overlaps each other substantially only in the area of the droplet 5 which has to be cured. Afterwards, the surface contour of the deposited droplets 5 and of the optical structure 2 is measured by the measurement means 7 using LASER triangular measurements. The measured geometric or optical parameters, in particular data on the surface contour are compared software-controlled to the desired shape of the optical structure 2 which has to be build up. Depending on the differences between the actual surface contour and the desired theoretical surface contour, further droplets of printing ink are ejected towards the substrate 3 in order to gradually approximate the actual shape of the surface contour to the desired shape. The steps of depositing droplets of printing ink, partially curing the deposited droplets and measuring the geometric characteristics are repeated iteratively until a satisfactory optical structure 2 is achieved. In this process, the printing parameters like printing time, kind of printing ink, ejection direction of the droplet, position of the deposited droplet 5 relatively to the substrate 3, quantity of ejected printing ink, size of the ejected droplet, total number of further droplets and/or the like are adjusted in dependency of the measured geometric and/or optical parameters in each iterative loop. If the desired shape is achieved, a final curing step with increased curing power is accomplished for finally hardening the whole optical structure 2. As exemplary shown in figure 2, the optical structure 2 comprises an optical prism in the present example.

During the printing procedure, the substrate 3 moves along a conveying direction 13 through the printer. It is conceivable that furthermore a picture, like a motif, lettering, logo or the like, is printed onto the substrate 3 by the same print head 1, wherein the printing of the picture is performed before, during or after printing the optical structure 2. The step of printing the picture is accomplished by depositing conventional colored printing ink onto the substrate 3, wherein the printing head 1 comprises an additional printing ink tank (not shown in figure 2) storing the conventional colored printing ink and an additional ejection device (not shown in figure 2) for ejecting the conventional colored printing ink from the additional printing ink tank to the substrate 3.

Figure 3 schematically shows a print head 1 according to an exemplary second embodiment of the present invention. The second embodiment is substantially similar to the first embodiment illustrated in figures 1 and 2, wherein the print head 1 is provided rotatable about a pivot axle 15 along a swivelling direction 17. The pivot axle 15 extends perpendicular to the conveying direction 13 of the substrate 3 and parallel to the plane of the substrate 3. Therefore, the illustrated four ejection devices 4 are rotatable in such a manner that the ejection directions 14 of the ejected droplets are movable relatively to the conveying direction 13 of the substrate 3. Preferably the print head 1 comprises a stepper motor (not shown in figure 3) swiveling the print head 1 together with the ejection devices 4 about the pivot axle 15 in order to adjust the position and the shape of the deposited droplets 5 relatively to the substrate 3 along the conveying direction 13 depending on the measured geometric and/or optical parameters of the deposited droplets 5. Thus, multiple droplets can be deposited on the same position of the substrate 3 and inaccuracies in the shape of the optical structure 2 measured by the measuring means 7 can be corrected even if the substrate 3 keep on moving along the conveying direction 13 with constant velocity. The print head 1 comprise a data cable 16 for connecting the print head 1 with an external computer (not shown).

**LIST OF REFERENCE NUMERALS**

|     |                        |
|-----|------------------------|
| 1   | print head             |
| 2   | optical structure      |
| 3   | substrate              |
| 4   | ejection device        |
| 5   | deposited droplet      |
| 6   | light path             |
| 7   | measurement means      |
| 7'  | LASER source           |
| 7'' | CCD camera             |
| 8   | curing device          |
| 9   | piezoelectric material |
| 10  | dotted curve           |
| 11  | pressure pulse         |
| 12  | chamber                |
| 13  | conveying direction    |
| 14  | ejection direction     |
| 15  | pivot axle             |
| 16  | data cable             |
| 17  | swivelling direction   |
| 18  | baseline               |

**PATENT CLAIMS**

1. Print head (1) for printing optical structures (2) on a substrate (3) comprising an ejection device (4) for ejecting at least one droplet of printing ink towards the substrate (3) in order to build up the optical structure (2), characterized in that the print head (1) comprises a measurement means (7) for contactless measuring at least one physical parameter of the at least one deposited droplet (5).
2. Print head (1) according to claim 1, characterized in that the measurement means (7) is configured for real-time measurements of the at least one physical parameter, in particular the measurement means (7) is configured for measuring the at least one physical parameter before, during and/or after depositing a further droplet of printing ink.
3. Print head (1) according to one of the preceding claims, characterized in that the measurement means (7) is configured for measuring at least one geometric parameter of the at least one deposited droplet, wherein the geometric parameter preferably comprises thickness and/or surface contour of a layer of deposited droplets (5).
4. Print head (1) according to one of the preceding claims, characterized in that the measurement means (7) is configured for determining an optical parameter of the at least one deposited droplets, wherein the optical parameter preferably comprises grade of transmission, grade of reflection and/or coloring of the layer of deposited droplets (5).
5. Print head (1) according to one of the preceding claims, characterized in that the measurement means (7) is configured for layer thickness measurements and/or for distance measurements.
6. Print head (1) according to one of the preceding claims, characterized in that the measurement means (7) is configured for ultrasonic measurements, optical interference measurements and/or optical triangulation measurements, preferably LASER- (Light Amplification by Stimulated Emission of Radiation) triangulation measurements.



7. Print head (1) according to claim 6, characterized in that the measurement means (7) comprises at least one LASER source (7') for projecting a laser spot onto the at least one deposited droplet (5) and at least one receiving means, preferably a CCD- (Charge Coupled Device) camera (7''), for receiving the laser light of the at least one LASER source (7') reflected by the at least one deposited droplet (5).
8. Print head (1) according to claim 7, characterized in that the measurement means (7) comprises an evaluation unit for calculating the geometric parameter of the at least one deposited droplet (5) from the position of the laser spot on the at least one deposited droplet (5) and from the known distance between the LASER source (7') and the receiving means (7'').
9. Print head (1) according to one of the preceding claims, characterized in that the print head (1) is configured for ejecting further droplets of printing ink in dependence upon the measured physical parameter.
10. Print head (1) according to one of the preceding claims, characterized in that the print head (1) comprises a curing device (8) for curing the at least one deposited droplet (5), wherein preferably the curing device (8) comprises at least one UV-LED (Ultraviolet Light Emitting Diode).
11. Print heads (1) according to claim 9, characterized in that the curing device (8) is configured for curing the at least one deposited droplet (5) and/or the optical structure (2) depending on the measured geometric and/or optical parameters.
12. Print head (1) according to one of the preceding claims, characterized in that the curing device (8) comprises at least two UV-LED's emitting light of different wavelength ranges, wherein the at least two UV-LED's are controlled depending on the measured geometric and/or optical parameters.
13. Upgrade kit for a conventional inkjet printer for printing optical structures (2) on a substrate (3) comprising a print head (1) according to one of the claims 1 to 12.
14. Printer comprising a print head (1) according to one of the claims 1 to 12.
15. Method for printing optical structures (2) on a substrate (3) by using a print head (1), in particular according to one the claims 1 to 12, comprising steps of providing the substrate (3) and ejecting at least one droplet of a printing ink (4) towards the

substrate (3) in order to build up the optical structure (2), characterized in that a further step of contactless measuring at least one physical parameter of the at least one deposited droplet (5) is performed.

16. Method according to claim 15, characterized in that real-time measurements of the at least one physical parameter are performed in the further step in such a manner that the at least one physical parameter is measured before and/or during a further droplet of printing ink is deposited.
17. Method according to one of the claims 15 or 16, characterized in that at least a geometric parameters of the at least one deposited droplet (5) is measured in the further step, wherein preferably a thickness and/or a surface contour of a layer of deposited droplets (5) is determined in the further step.
18. Method according to one of the claims 15 to 17, characterized in that an optical parameter of the at least on deposited droplet (5) is determined in the further step, wherein preferably a grade of transmission, a grade of reflection and/or a coloring of the layer of deposited droplets (5) is determined in the further step.
19. Method according to one of the claims 15 or 18, characterized in that further steps of depositing droplets of printing ink on the substrate are performed depending on the at least one physical parameter, preferably the printing time, the kind of printing ink, the ejection direction of the droplet, the position of the deposited droplet on the substrate, the quantity of ejected printing ink, the sizes of the droplets, the number of further droplets are determined depending on the at least one physical parameter.
20. Method according to one of the clams 15 to 19, characterized in that layer thickness measurements and/or distance measurements are performed in the further step.
21. Method according to one of the claims 15 to 20, characterized in that ultrasonic measurements, optical interference measurements and/or optical triangulation measurements are performed in the further step, wherein preferably triangulation measurements are performed in the further step.
22. Method according to claim 21, characterized in that LASER-triangulation measurements are performed in the further step, wherein a laser spot is projected onto the at least one deposited droplet (5) by a LASER source (7') of the printing

head (1) and laser light reflected by the at least one deposited droplet (5) is received by a receiving means (7''), preferably a CCD-camera of the printing head (1).

23. Method according to claim 22, characterized in that the at least one physical parameter of the at least one deposited droplet (5) are calculated by evaluating the position of the laser spot on the at least one deposited droplet (5) and the known distance between the LASER source (7') and the receiving means (7'').
24. Method according to one of the claims 15 to 23, characterized in that the at least one deposited droplet (5) is cured by a curing device (8), wherein preferably light of different wavelength ranges is emitted by two different light sources.
25. Method according to claim 24, characterized in that the at least one deposited droplet (5) and/or the optical structure (2) is cured depending on the at least one physical parameter, in particular the power of the curing device is determined depending on the at least one physical parameter and/or a certain light source is used depending on the at least one physical parameter.
26. Method according to one of the claims 15 to 25, characterized in that the method comprises a step of moving and preferably rotating the print head (1) to a certain position relatively to the substrate (3) depending on the at least one physical parameter which has been measured before ejecting a further droplet.

Fig. 1

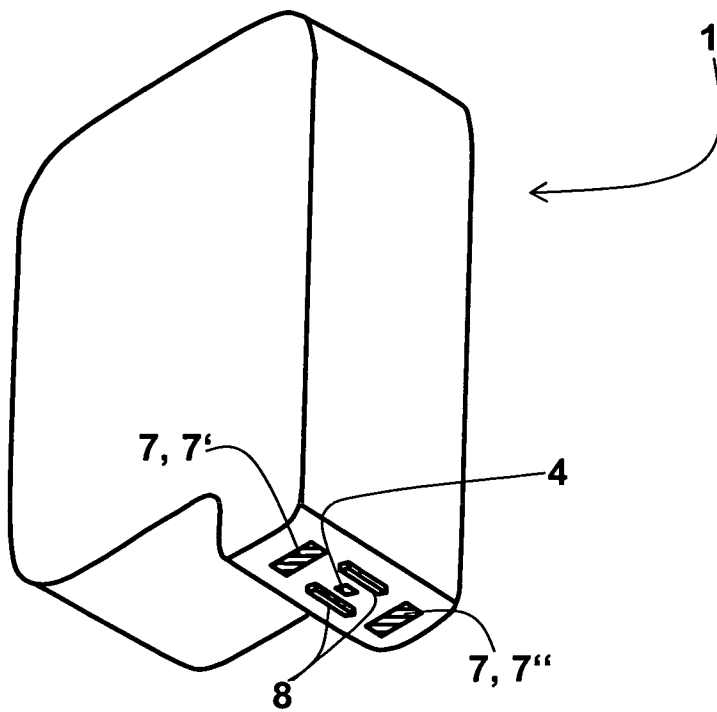

Fig. 2

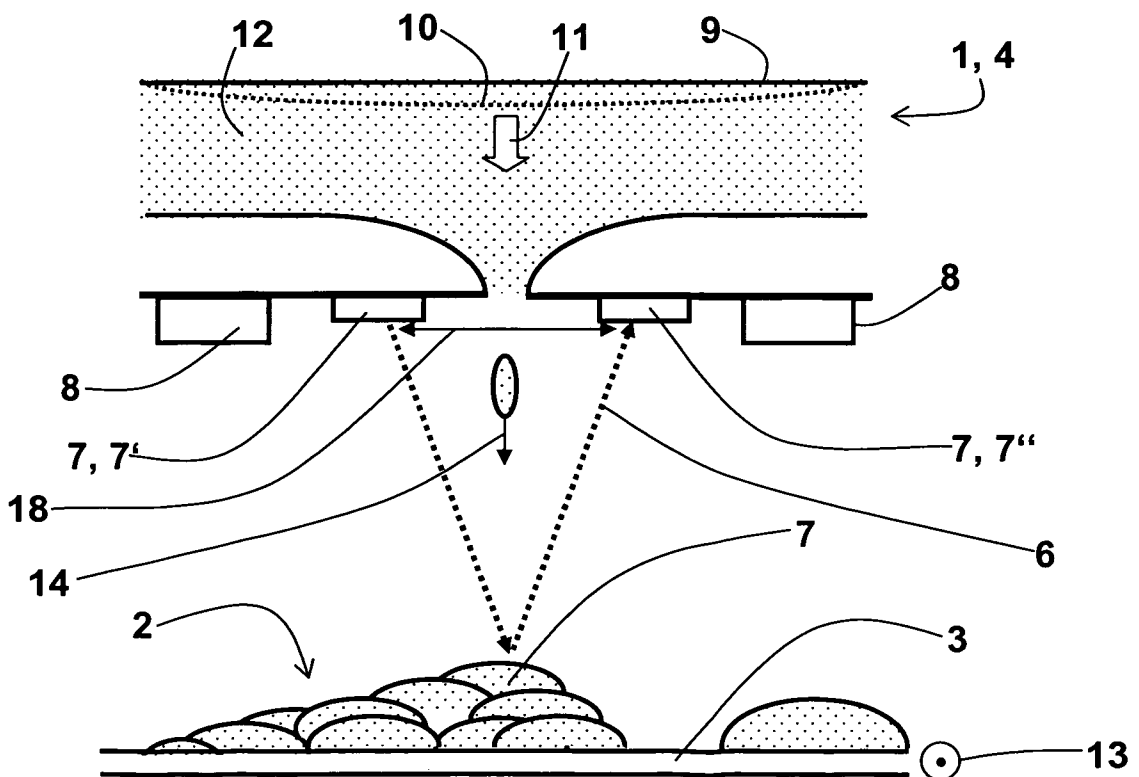
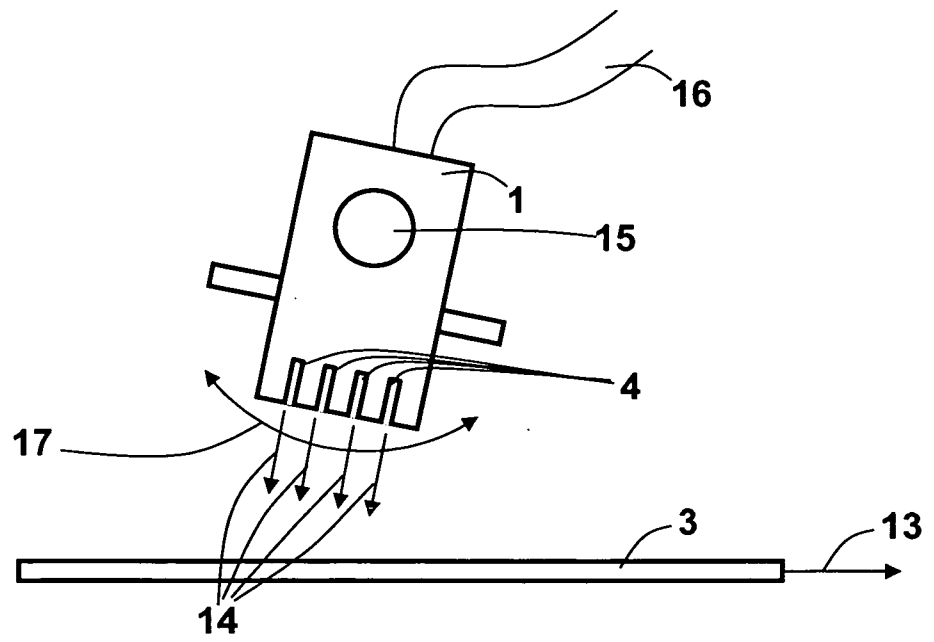

Fig. 3



## INTERNATIONAL SEARCH REPORT

International application No

PCT/EP2012/000025

A. CLASSIFICATION OF SUBJECT MATTER  
 INV. B29C41/36 B41J2/21  
 ADD.

According to International Patent Classification (IPC) or to both national classification and IPC

## B. FIELDS SEARCHED

Minimum documentation searched (classification system followed by classification symbols)  
 B29C G02B B41J

Documentation searched other than minimum documentation to the extent that such documents are included in the fields searched

Electronic data base consulted during the international search (name of data base and, where practical, search terms used)

EPO-Internal

## C. DOCUMENTS CONSIDERED TO BE RELEVANT

| Category* | Citation of document, with indication, where appropriate, of the relevant passages  | Relevant to claim No.                 |
|-----------|---|---------------------------------------|
| X         | US 5 707 684 A (HAYES DONALD J [US] ET AL)<br>13 January 1998 (1998-01-13)  | 1-3,5,<br>9-11,<br>13-17,<br>19-21,24 |
| Y         | column 9, line 14 - column 10, line 18<br>column 13, line 8 - column 14, line 44  | 4,6-8,<br>12,18,<br>22,23,<br>25,26   |
| Y         | -----<br>US 2009/016757 A1 (PRIEBE ALAN R [US] ET<br>AL) 15 January 2009 (2009-01-15)<br>paragraph [0050]                     | 4,18                                  |
| Y         | -----<br>US 2004/233265 A1 (KOJIMA KENJI [JP] ET<br>AL) 25 November 2004 (2004-11-25)<br>paragraph [0084]<br>paragraph [0086] | 6-8,22,<br>23,26                      |
|           | -----<br>-/--   |                                       |

Further documents are listed in the continuation of Box C.

See patent family annex.

\* Special categories of cited documents :

"A" document defining the general state of the art which is not considered to be of particular relevance  
 "E" earlier document but published on or after the international filing date  
 "L" document which may throw doubts on priority claim(s) or which is cited to establish the publication date of another citation or other special reason (as specified)  
 "O" document referring to an oral disclosure, use, exhibition or other means  
 "P" document published prior to the international filing date but later than the priority date claimed

"T" later document published after the international filing date or priority date and not in conflict with the application but cited to understand the principle or theory underlying the invention  
 "X" document of particular relevance; the claimed invention cannot be considered novel or cannot be considered to involve an inventive step when the document is taken alone  
 "Y" document of particular relevance; the claimed invention cannot be considered to involve an inventive step when the document is combined with one or more other such documents, such combination being obvious to a person skilled in the art.  
 "&" document member of the same patent family

Date of the actual completion of the international search

13 March 2012

Date of mailing of the international search report

26/03/2012

Name and mailing address of the ISA/

European Patent Office, P.B. 5818 Patentlaan 2  
 NL - 2280 HV Rijswijk  
 Tel. (+31-70) 340-2040,  
 Fax: (+31-70) 340-3016

Authorized officer

Gavaza, Bogdan

## INTERNATIONAL SEARCH REPORT

International application No  
PCT/EP2012/000025

| C(Continuation). DOCUMENTS CONSIDERED TO BE RELEVANT |  |                       |
|--|--|-----------------------|
| Category*  | Citation of document, with indication, where appropriate, of the relevant passages   | Relevant to claim No. |
| Y  | US 2010/208006 A1 (SELINFREUND RICHARD [US]) 19 August 2010 (2010-08-19)<br>paragraph [0031] - paragraph [0033]<br>-----   | 12                    |
| Y  | US 2008/049088 A1 (CODOS RICHARD N [US])<br>28 February 2008 (2008-02-28)<br>paragraph [0040]<br>-----   | 25                    |
| A  | EP 1 225 472 A2 (SEIKO EPSON CORP [JP])<br>24 July 2002 (2002-07-24)<br>paragraph [0098]<br>-----  | 26                    |
| A  | US 2004/231594 A1 (EDWARDS CHARLES O [US]<br>ET AL) 25 November 2004 (2004-11-25)<br>paragraph [0062] - paragraph [0065]<br>paragraph [0061] - paragraph [0065]<br>----- | 26                    |
| A  | WO 2006/029268 A2 (OPHTHONIX INC [US]; LAI<br>SHUI T [US]; SVERDRUP LAWRENCE [US])<br>16 March 2006 (2006-03-16)<br>paragraph [0061] - paragraph [0054]<br>-----         | 1-26                  |

# INTERNATIONAL SEARCH REPORT

Information on patent family members

International application No

PCT/EP2012/000025

| Patent document cited in search report | Publication date | Patent family member(s) | Publication date |
|--|------------------|-------------------------|------------------|
| US 5707684                             | A                | 13-01-1998              | AU 1935495 A     |
|  |                  |                         | US 5498444 A     |
|  |                  |                         | US 5707684 A     |
|  |                  |                         | WO 9523037 A1    |
| -----                                  |                  |                         |                  |
| US 2009016757                          | A1               | 15-01-2009              | EP 2168014 A2    |
|  |                  |                         | JP 2010533314 A  |
|  |                  |                         | US 2009016757 A1 |
|  |                  |                         | WO 2009011773 A2 |
| -----                                  |                  |                         |                  |
| US 2004233265                          | A1               | 25-11-2004              | JP 4055570 B2    |
|  |                  |                         | JP 2004198856 A  |
|  |                  |                         | US 2004233265 A1 |
| -----                                  |                  |                         |                  |
| US 2010208006                          | A1               | 19-08-2010              | CN 102326077 A   |
|  |                  |                         | EP 2399127 A2    |
|  |                  |                         | US 2010208006 A1 |
|  |                  |                         | WO 2010096501 A2 |
| -----                                  |                  |                         |                  |
| US 2008049088                          | A1               | 28-02-2008              | US 2008049088 A1 |
|  |                  |                         | US 2009225145 A1 |
| -----                                  |                  |                         |                  |
| EP 1225472                             | A2               | 24-07-2002              | CN 1365891 A     |
|  |                  |                         | EP 1225472 A2    |
|  |                  |                         | JP 3953776 B2    |
|  |                  |                         | JP 2002273868 A  |
|  |                  |                         | KR 20020061521 A |
|  |                  |                         | TW I294055 B     |
|  |                  |                         | US 2002105688 A1 |
|  |                  |                         | US 2006146379 A1 |
| -----                                  |                  |                         |                  |
| US 2004231594                          | A1               | 25-11-2004              | NONE             |
| -----                                  |                  |                         |                  |
| WO 2006029268                          | A2               | 16-03-2006              | NONE             |
| -----                                  |                  |                         |                  |