

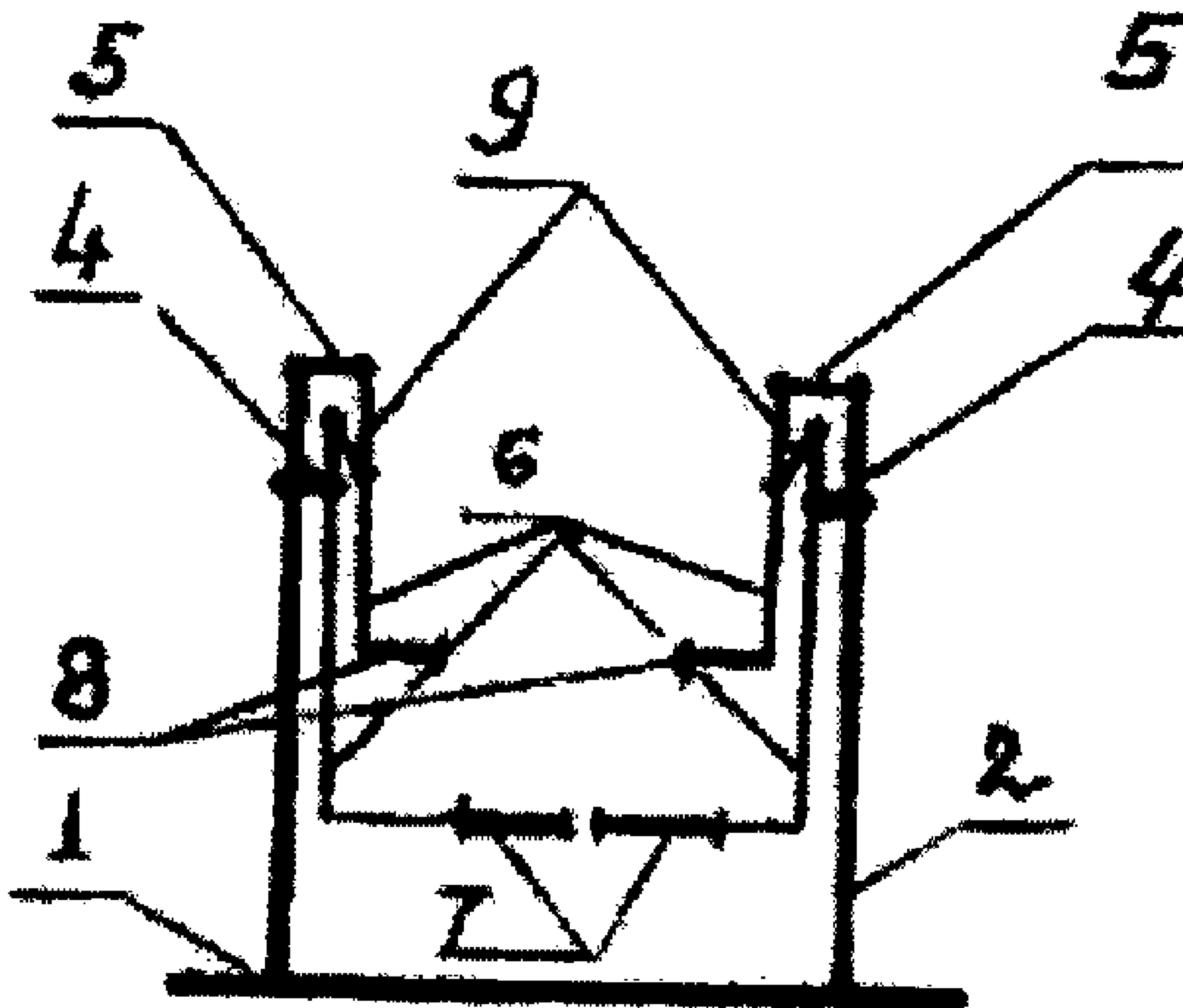

(22) Date de dépôt/Filing Date: 2004/10/29
 (41) Mise à la disp. pub./Open to Public Insp.: 2005/05/17
 (45) Date de délivrance/Issue Date: 2013/07/02
 (30) Priorités/Priorities: 2003/11/17 (GB GB 0326735.8);
 2004/07/05 (GB GB 0415060.3)

(51) Cl.Int./Int.Cl. *A63B 23/02* (2006.01),
A63B 22/00 (2006.01), *A63B 23/035* (2006.01)
 (72) Inventeur/Inventor:
 AKHMETOV, ZINNUR, GB
 (73) Propriétaire/Owner:
 AKHMETOV, ZINNUR, GB
 (74) Agent: NA

(54) Titre : EXERCISEUR DE COLONNE VERTEBRALE CARDIO-VASCULAIRE
 (54) Title: CARDIOVASCULAR SPINE EXERCISER



(57) Abrégé/Abstract:

The cardiovascular spine exercisers designed for exercising with the spine in a free horizontal position, with the user positioned from above, comprises: -a supporting frame with rear and fore pivot points, -two foot and two hand walking units pivotally attached



(57) **Abrégé(suite)/Abstract(continued):**

to and suspended below a corresponding pivot points, provided the hand supports level is above the foot supports level, -a kinematic transmission connecting the pairs of the walking units with possibility to swing the foot and hand walking units either in phase or in opposite direction. In the variant of the cardiovascular spine exerciser shown at the Fig.14, Fig.15, Fig.16 - the supporting frame comprises a horizontal basis element (1) and two vertical members (2) with pivot points (4 and 5) at the upper ends, with foot (6,7) and hand (6,8) walking units pivotally attached by the upper ends to the corresponding vertical member pivot points (4 and 5), with outwardly facing supports, safety means (12) mounted on the top of the vertical members.

ABSTRACT

The cardiovascular spine exercisers designed for exercising with the spine in a free horizontal position, with the user positioned from above, comprises:

- a supporting frame with rear and fore pivot points,
- two foot and two hand walking units pivotally attached to and suspended below a corresponding pivot points, provided the hand supports level is above the foot supports level,
- a kinematic transmission connecting the pairs of the walking units with possibility to swing the foot and hand walking units either in phase or in opposite direction.

In the variant of the cardiovascular spine exerciser shown at the Fig.14, Fig.15, Fig.16 - the supporting frame comprises a horizontal basis element (1) and two vertical members (2) with pivot points (4 and 5) at the upper ends, with foot (6,7) and hand (6,8) walking units pivotally attached by the upper ends to the corresponding vertical member pivot points (4 and 5), with outwardly facing supports, safety means (12) mounted on the top of the vertical members.

TITLE OF INVENTION

CARDIOVASCULAR SPINE EXERCISER

TECHNICAL FIELD

The present invention relates to cardiovascular spine exercisers for training cardiovascular system, for exercising and strengthening vertebrae and the muscles of the spinal column, for the spine recreation. More particularly, but not exclusively, the cardiovascular spine exerciser is for use in sport as a training and exercising device, and in medicine as a mechanical therapy device.

BACKGROUND OF INVENTION

Existing exercise apparatuses repeat (reduplicate) what people do during 24 hours – stand, sit, lie, walk, jog etc. The spine exercisers being patented provide a new pose, new movement and give excellent active recreation. When you are tired and feel your spine uncomfortable especially after monotone sedentary work, you try to stretch yourself, to hog, – exactly this “S”-image vertebrae pose gives you this simple, universal and effective spine exerciser.

Number of patents of walking trainers can be found:

GB2007987, GB2010101, GB21309000, GB2323304, WO03049816, US3976058.

But mentioned exercisers don't provide the spine free horizontal position and are not designed for spine recreation.

The principal purpose of this invention is the creation of a simple, universal and effective cardiovascular spine exerciser for exercising the vertebral joints, training the muscles of the spinal column and the musculoskeletal system as a whole, in condition which are most favourable and natural to the spine into its natural free “S” shaped position, in combination with the specific synchronization of the motions of arms and legs, i.e. with the natural synchronization of the forces being applied to the spine.

The cardiovascular spine exerciser being patented is designed goal-directed for training and strengthening the vertebrae, for the spine recreation.

SUMMARY OF THE INVENTION

According to the present invention there is provided a cardiovascular spine exerciser comprising:

- a supporting framework with rear and fore pivot points;
- two foot walking units pivotally attached to and suspended below a rear pivot points on the framework, each foot walking unit having a foot support located substantially at the lower end thereof for the engagement of the users foot;
- two hand walking units pivotally attached to and suspended below a fore pivot points on the framework, each hand walking unit having a hand support located substantially at the lower end thereof for the engagement of the users hand;
- wherein, the hand supports are generally positioned at a level above the foot supports and spaced horizontally therefrom, such that a user may perform a walking motion on the foot and hand supports while keeping his/her spine in a substantially horizontal position above the foot and hand supports;
- a kinematic transmission, connecting the walking units with possibility to swing the foot and hand walking units either in phase or in opposite direction.

The kinematic transmission between the walking units may comprise one of a shaft drive, belt drive, cord drive, chain drive or combination of the mentioned above.

The first embodiment of the cardiovascular spine exerciser comprises:

- a supporting framework consisting of:
a horizontal basis element,
vertical members,
two longitudinal guide structures with two pivot points each,
the distance between the rear and fore pivot points is adjustable;
- two an adjustable length foot walking units
attached by the upper ends to the rear pivot points between the longitudinal guide structures with inwardly facing foot supports,
and adapted to be engaged by the feet of a user;
- two an adjustable length hand walking units
attached by the upper ends to the fore pivot points between the longitudinal guide structures with inwardly facing hand supports,
and adapted to be engaged by the hands of a user.

The second embodiment of the cardiovascular spine exerciser comprises an adjustable length hand walking units attached to the outer side of the longitudinal guide structures with outwardly facing hand supports.

A safety belt or safety desk attached to the supporting framework for secure exercising.

In the next embodiment of the cardiovascular spine exerciser the supporting framework comprises one longitudinal guide structure attached to the vertical members, pair of the hand walking units attached to the fore pivot points of the longitudinal guide structure with outwardly facing hand supports, pair of the foot walking units attached to rear pivot points of the longitudinal guide structure with outwardly facing foot supports.

A safety desk attached to the supporting framework for secure exercising.

In a further aspect the present invention provides the cardiovascular spine exerciser consisting of:

- a supporting framework comprises a horizontal basis element and vertical members with pivot points at the upper ends, fore and rear vertical members attached to the horizontal basis element with capability of tilting forward and backward and fixing at a specified angle to the horizontal, this gives possibility to adjust the distance between the foot and hand supports,
- two foot walking units attached by the upper ends to the pivot points between the rear vertical members, with inwardly facing foot supports,
- two hand walking units attached by the upper ends to the pivot points between the fore vertical members with inwardly facing hand supports.

The next embodiment of the cardiovascular spine exerciser comprises two hand walking units attached by the upper ends to the outer side of the fore vertical member pivot points, with outwardly facing hand supports.

According to a further embodiment of the cardiovascular spine exerciser the hand walking units and foot walking units pivotally attached by the upper ends to the outer side of the vertical member pivot points with outwardly facing hand and foot supports.

The cardiovascular spine exerciser can comprise a mechanism of adjustable training load.

BRIEF DESCRIPTION OF THE SEVERAL VIEWS OF THE DRAWINGS

The present invention will now be described by way of examples only and not in any limited sense with reference to the accompany drawings in which:

Fig.1 - is a front view and Fig.2 – is a side view of the cardiovascular spine exerciser with both hand and foot walking units positioned between the longitudinal guide structures.

Fig.3 – is a front view and Fig.4 – is a side view of the cardiovascular spine exerciser with the foot walking units attached between the longitudinal guide structures, and with the hand walking units attached outside of the longitudinal guide structures.

Fig.5 – is a side view and Fig.6 – is a front view of the cardiovascular spine exerciser with the supporting frame comprises one longitudinal guide structure and with outwardly facing hand and foot supports.

Fig.7, Fig.8, Fig.9 – is the cardiovascular spine exerciser with the supporting frame comprises a horizontal basis element and vertical members with the foot and hand walking units attached between the vertical members,
Fig.7 – is a side view,
Fig.8 - is a front view,
Fig.9 - is a view from above.

Fig.10, Fig.11, Fig.12, Fig.13 – is the cardiovascular spine exerciser with the supporting frame comprises a horizontal basis element and vertical members, with the foot walking units attached between the vertical members and with the hand walking units attached outside of the vertical members,
Fig.10 – is a side view,
Fig.11 – is a rear view,
Fig.12 – is a front view,
Fig.13 – is a view from above.

Fig.14, Fig.15, Fig.16 – is the cardiovascular spine exerciser with the supporting frame comprises a horizontal basis element and vertical members with the foot and hand walking units attached outside of the vertical members.

Fig.14 - is a view from above, the cardiovascular spine exerciser with one rear and two fore vertical members.

Fig.15 – is a side view,

Fig.16 - is a rear view, the cardiovascular spine exerciser with one rear and two fore vertical members.

DETAILED DESCRIPTION OF THE INVENTION

Further details and advantages of the invention will become apparent from the following more detailed description.

Fig. 1, Fig.2 - is the cardiovascular spine exerciser with the supporting frame consisting of the horizontal basis element (1), vertical members (2), two longitudinal guide structures (3), with two pivot points each, the distance between the rear (4) and fore (5) pivot points is adjustable, two foot walking units, comprise an adjustable length connecting member (6) and a foot supports (7), the connecting members (6) attached by the upper ends to the rear pivot points (4) between the longitudinal guide structures (3) with inwardly facing foot supports (7), two hand walking units comprise an adjustable length connecting members (6) and a hand supports (8), connecting members (6) attached by the upper ends to the fore pivot points (5) between the longitudinal guide structures (3) with inwardly facing hand supports (7), depending downwardly of pivot points (4,5), the level of the hand supports (8) is above of the level of the foot supports (7), the distance between the hand supports (8) is wider then the distance between the feet supports (7), the kinematic transmission consisting of the shaft drive (9), fastened to the fastening point (10) to provide swinging of the foot and hand walking units in opposite direction,

the shaft drive (9) can be fastened to the fastening point (11) to provide swinging of the foot and hand walking units in phase,

the safety belt or desk attached athwart between the longitudinal guide structures (3) provides support of the user's body for secure exercising (it's not shown on the drawing).

Fig.3, Fig.4, - is the cardiovascular spine exerciser with two hand walking units (6,8) attached by the upper ends to the fore pivot points (5) to the outer side of the longitudinal guide structures (3) with outwardly facing hand supports (8).

Fig. 5, Fig.6 - is the cardiovascular spine exerciser with the supporting frame comprises one longitudinal guide structure (3) attached to the vertical members (2), pair of the foot walking units (6,7) attached to rear pivot points of the guide structure, with outwardly facing foot supports (7), pair of the hand walking units (6,8) attached to the fore pivot points of the guide structure, with outwardly facing hand supports (8), the safety desk (12) attached to the support device provides secure exercising.

Fig. 7, Fig.8, Fig.9 - is the cardiovascular spine exerciser with the supporting frame comprises the horizontal basis element (1) and vertical members (2) with pivot points at the upper ends, rear and fore vertical members (2) attached to the horizontal basis element(1) with capability of tilting forward and backward and fixing at a specified angle to the horizontal, what allows to adjust distance between the rear (4) and fore (5) pivot points, foot walking units pivotally attached by the upper ends to the rear vertical member pivot points (4) , with inwardly facing foot supports(7), two hand walking units pivotally attached by the upper ends to the fore vertical member pivot points (5) , with inwardly facing hand supports(8),

Fig.10, Fig.11, Fig.12, Fig.13 - is the cardiovascular spine exerciser with two hand walking units pivotally attached by the upper ends to the fore vertical member pivot points (5) , with outwardly facing hand supports(8), the safety mean (12) mounted on the top of the vertical members.

Fig.14, Fig.15, Fig.16 - is the cardiovascular spine exerciser with the supporting frame comprises horizontal basis element (1) and vertical members (2) with pivot points (4 and 5) at the upper ends,

with foot(6,7) and hand (6,8) walking units pivotally attached by the upper ends to the corresponding vertical member pivot points (4 and 5) , with outwardly facing supports, safety means (12) mounted on the top of the vertical members.

The cardiovascular spine exerciser being patented is used as follows:

to be adjusted:

- required distance between the rear and fore walking units,
- desirable kinematic connection of the pairs of the walking units,
- required level of the training load.

The exercising is carried out by user positioned from above with extremities are based on the corresponding supports and with a free horizontal spine position.

By moving foot and hand supports forward and back the user provides good general physical training and exercises the deep muscles of the spine and vertebral joints.

Cardiovascular spine exercisers do not contain any complicated elements, are simple to manufacture, and are comfortable and effective in the use, they have all qualities of notorious exercise bikes and additionally provide important benefits:

- an active recreation of the spine
- strengthening of vertebrae joints and deep muscles,
- provide pliability of vertebrae,
- expansion of chest and elimination of slouch,
- correction of posture,
- massage of viscera (prostate),
- training with the horizontal spine position reduces load on the heart.

All mentioned above embodiments of cardiovascular spine exercisers provide free “S” shaped natural vertebrae position and even training load on the muscles of the spinal column, what provides favourable conditions for the posture correction.

They are recommended for sport, for general physical well being and mechanical-therapy, for the prevention of spinal curvature, for the use by people with a sedentary or low-mobility way of life, for school children, students, for marine crew members and so on.

Applicant

Zinnoor Akhmetov

CLAIMS

1. A cardiovascular spine exerciser comprising:
 - a supporting framework with rear and fore pivot points;
 - two foot walking units pivotally attached to and suspended below the rear pivot points on the framework, each foot walking unit having a foot support located substantially at the lower end thereof for the engagement of the users foot;
 - two hand walking units pivotally attached to and suspended below the fore pivot points on the framework, each hand walking unit having a hand support located substantially at the lower end thereof for the engagement of the users hand;
 - wherein, the hand supports are generally positioned at a level above the foot supports and spaced horizontally therefrom, such that a user may perform a walking motion on the foot and hand supports while keeping his/her spine in a substantially horizontal position above the foot and hand supports;
 - a kinematic transmission, connecting the walking units with possibility to swing the foot and hand walking units either in phase or in opposite direction.

2. A cardiovascular spine exerciser as claimed in Claim 1, wherein the kinematic transmission between the walking units comprise one of a shaft drive, belt drive, cord drive, chain drive or combination of mentioned above.

3. A cardiovascular spine exerciser as claimed in Claims 1 to 2, wherein the cardiovascular spine exerciser provides a mechanism of adjustable training load.

4. A cardiovascular spine exerciser as claimed in Claims 1 to 3, comprising a safety means attached to the support device for secure exercising.

CARDIOVASCULAR SPINE EXERCISER
Z Akhmetov

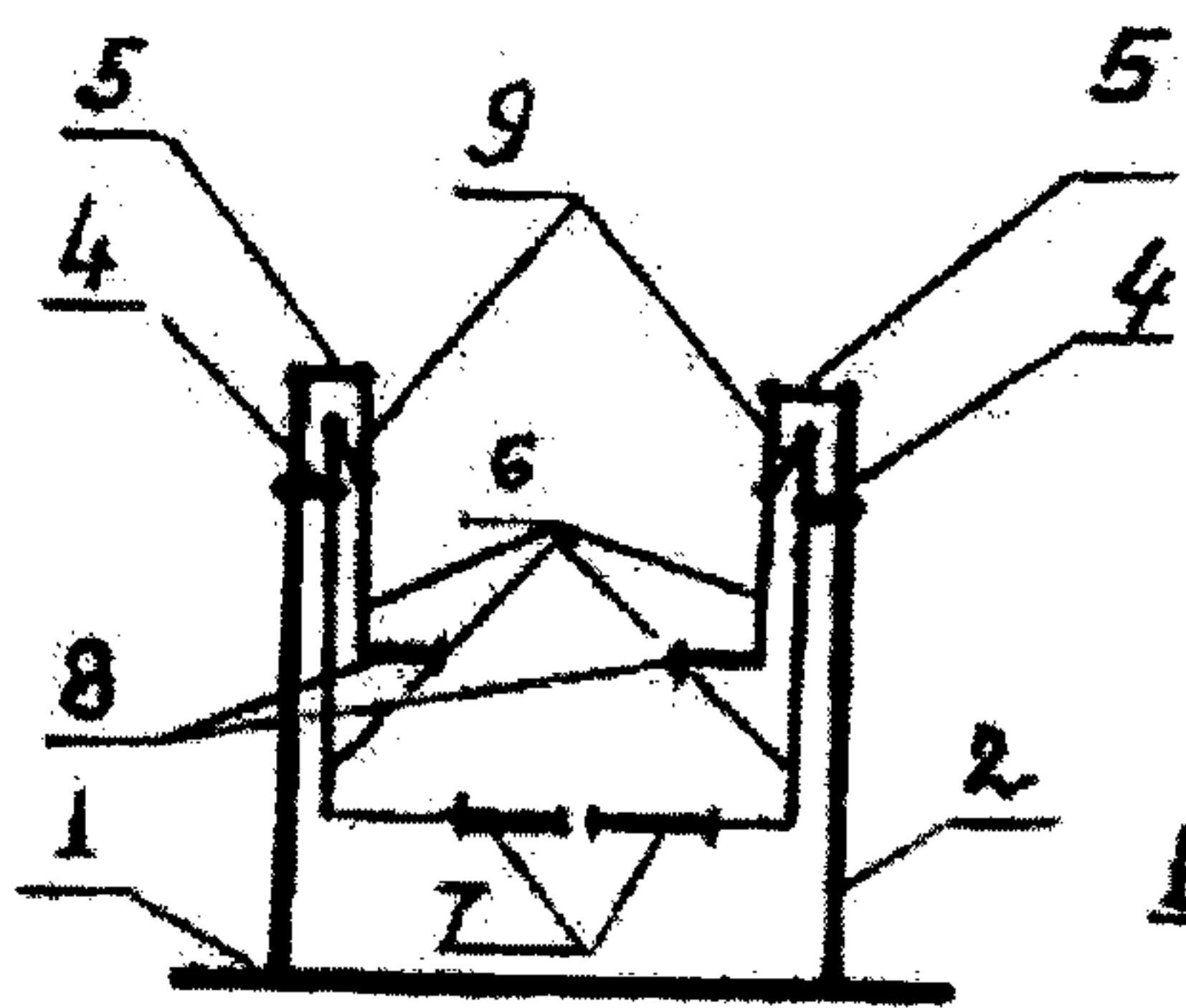

Fig 1

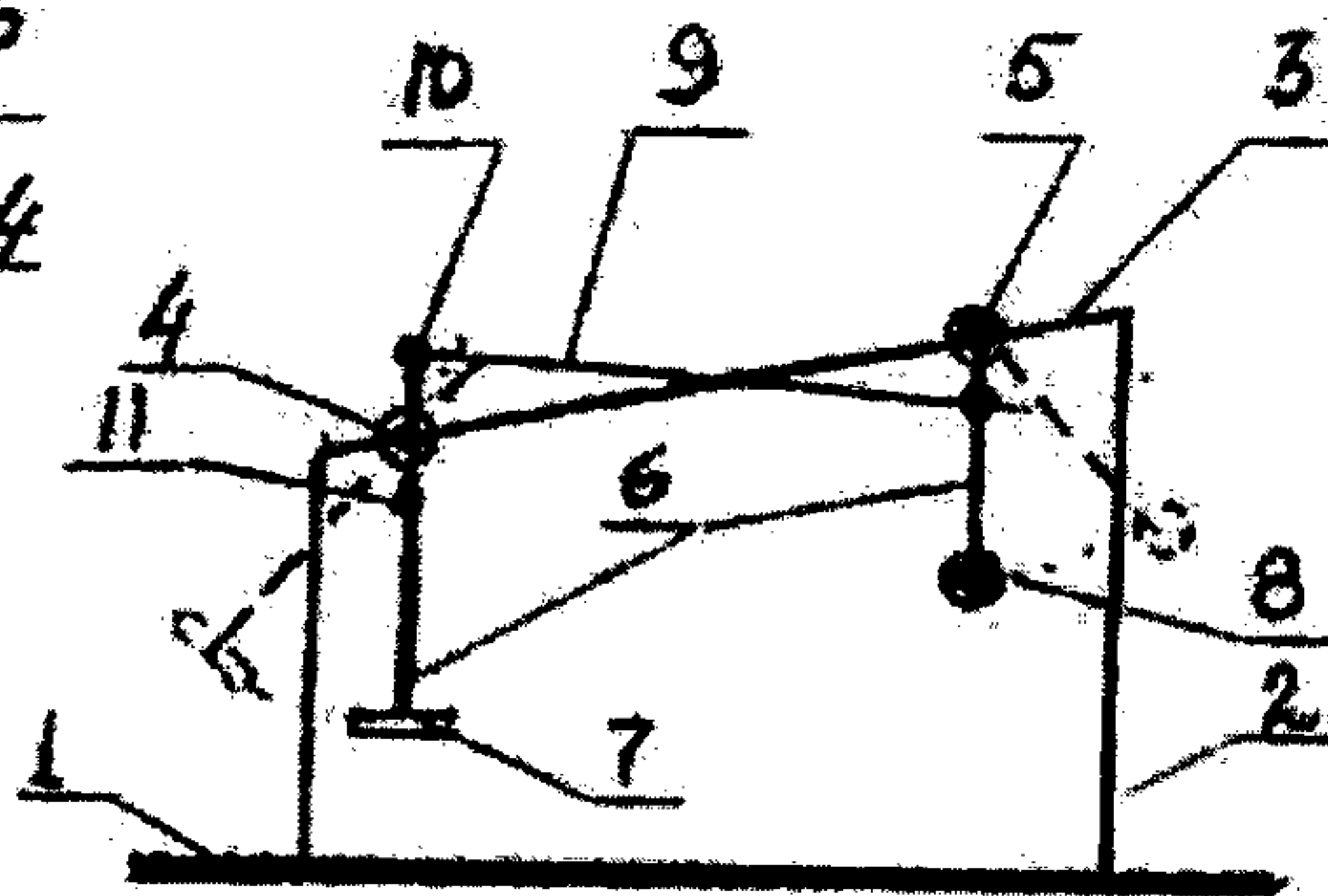

Fig 2

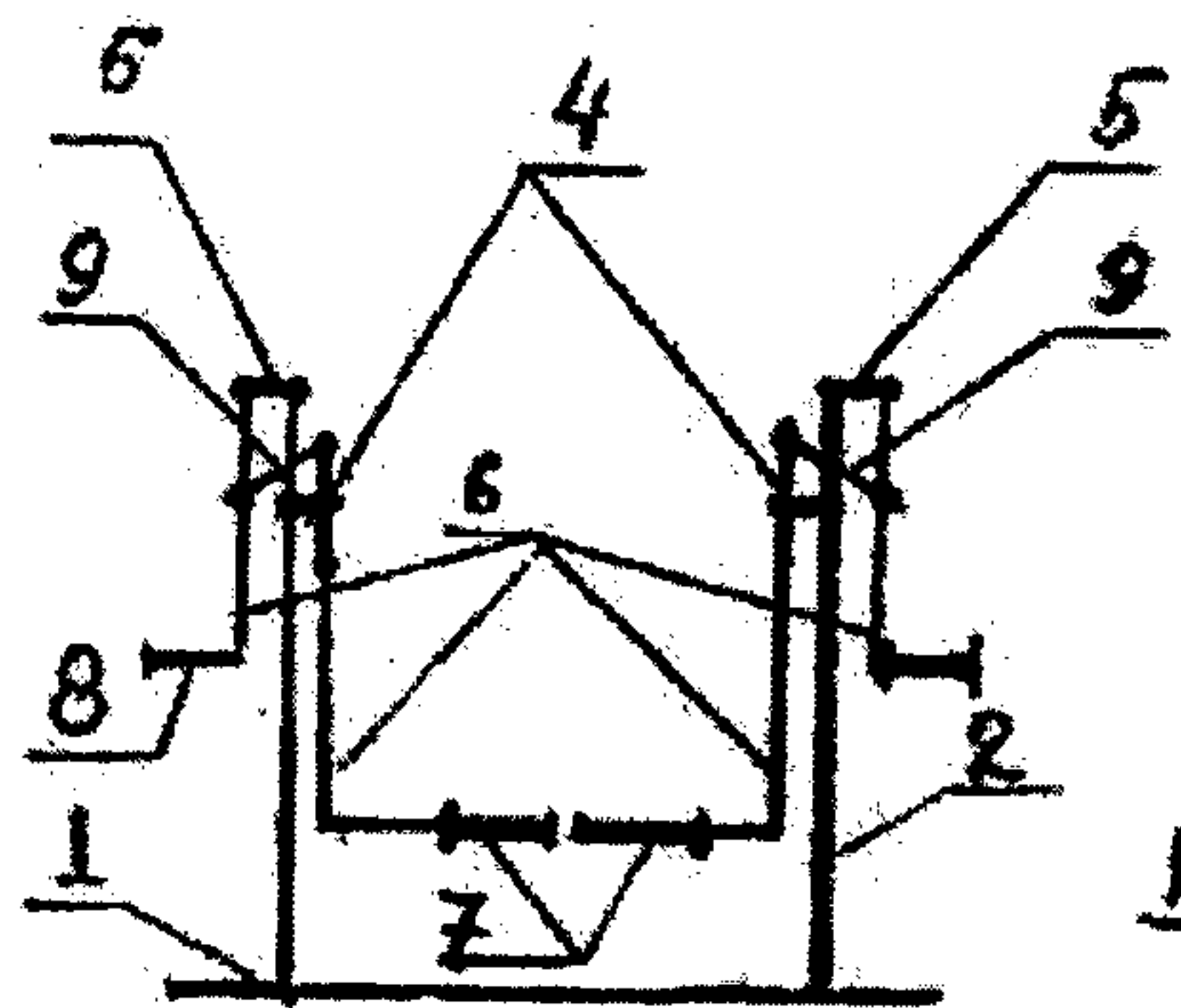

Fig 3

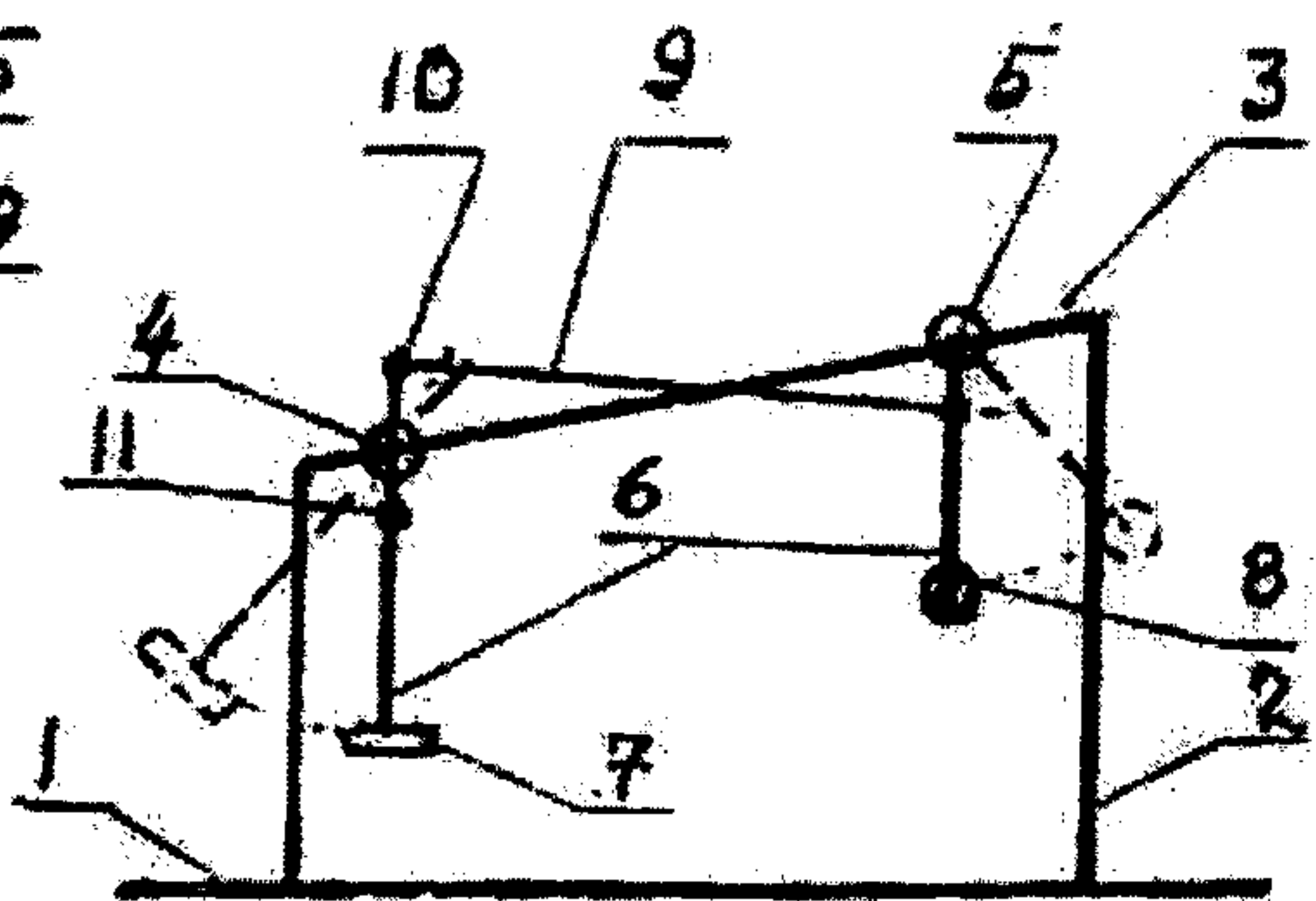

Fig 4

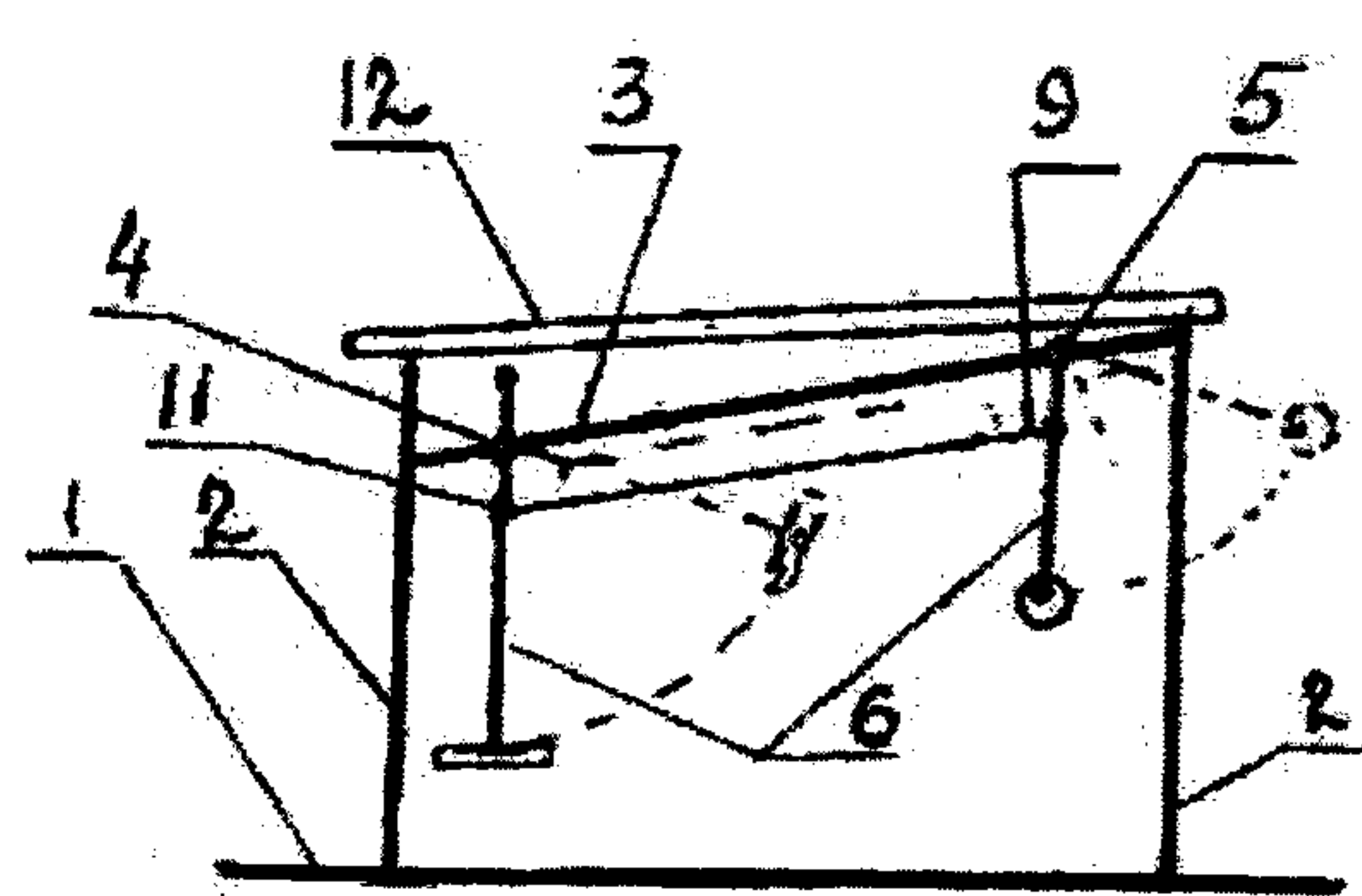

Fig 5

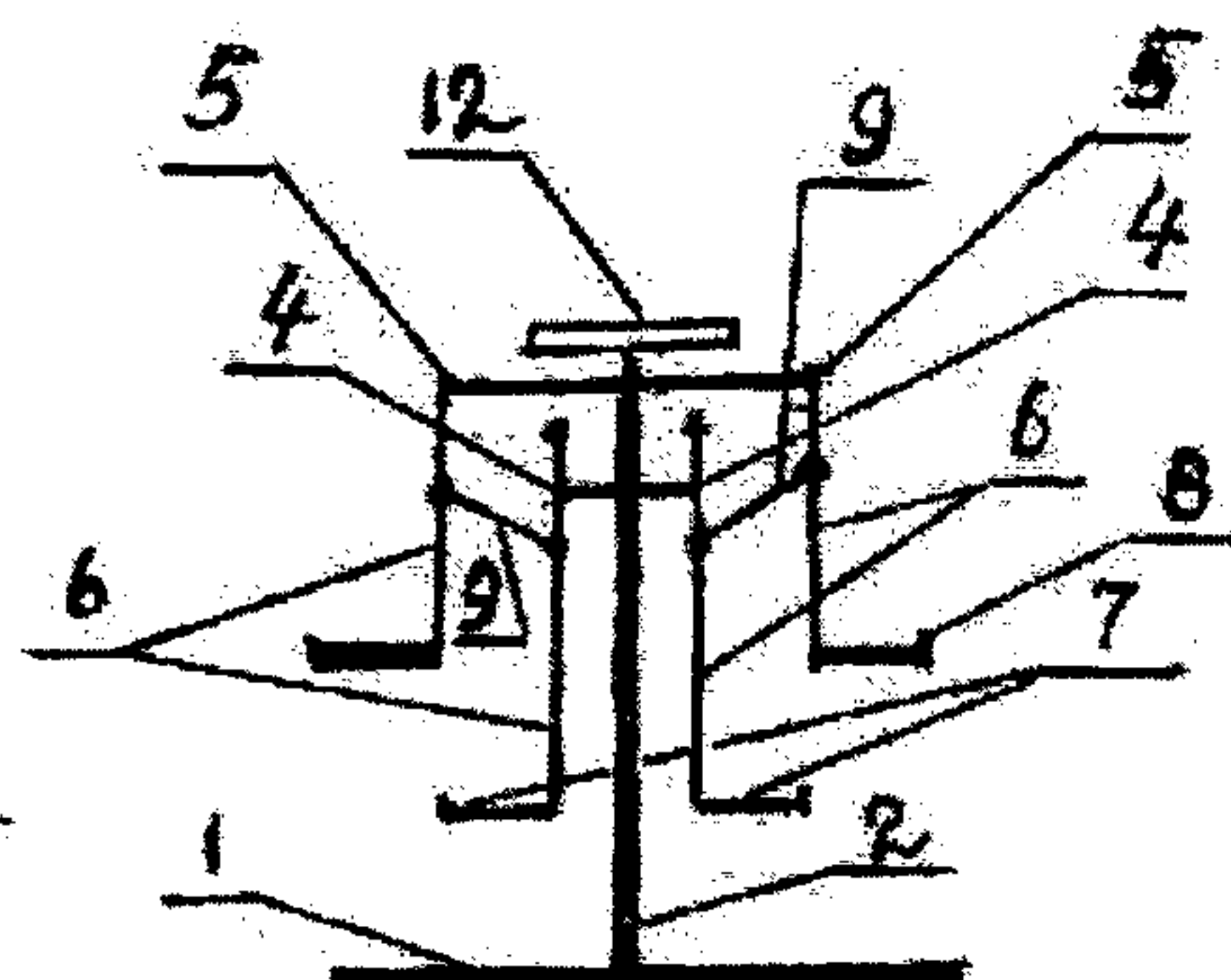

Fig 6

CARDIOVASCULAR SPINE EXERCISER
Z Akhmetov

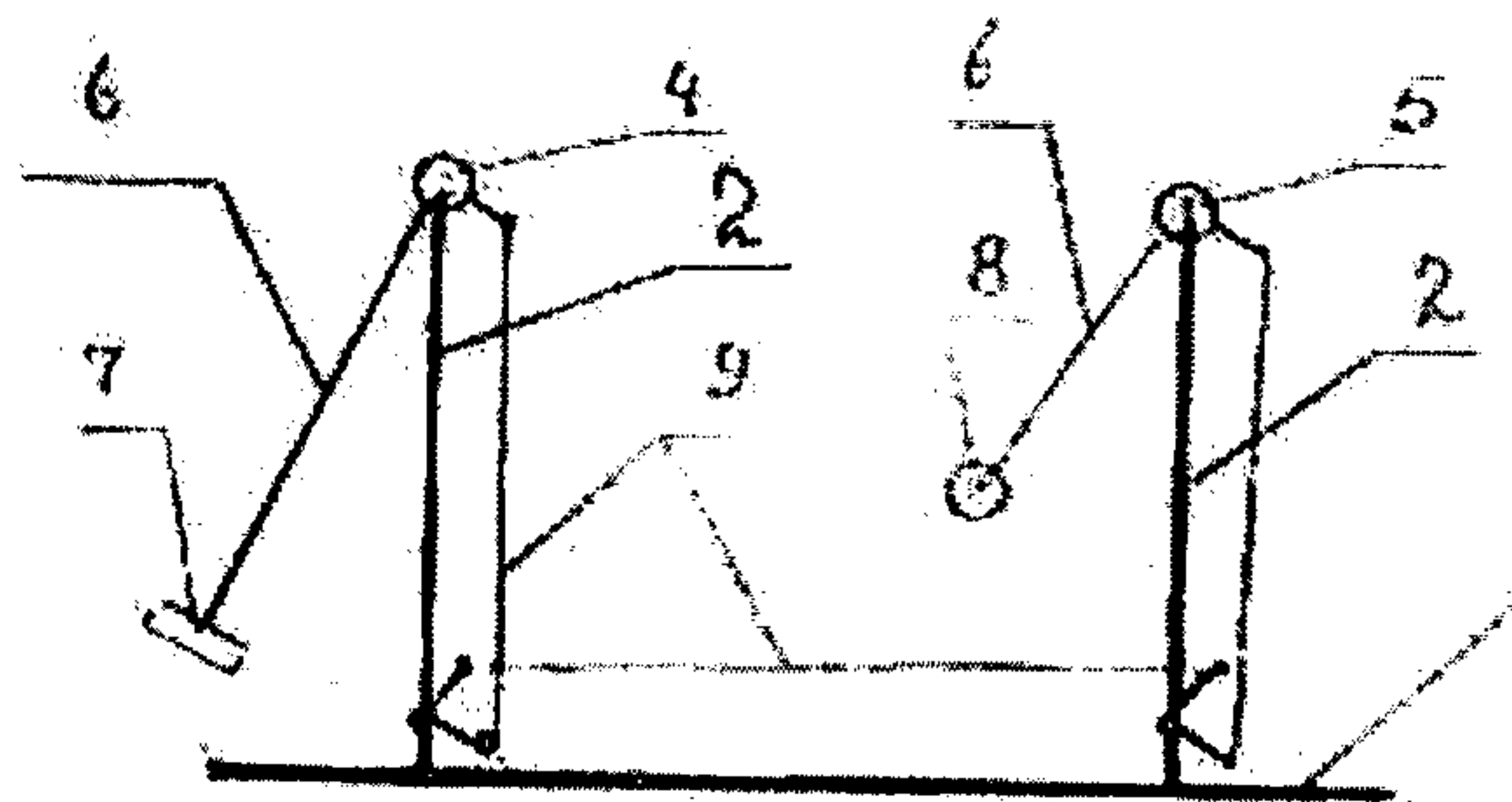

Fig 7

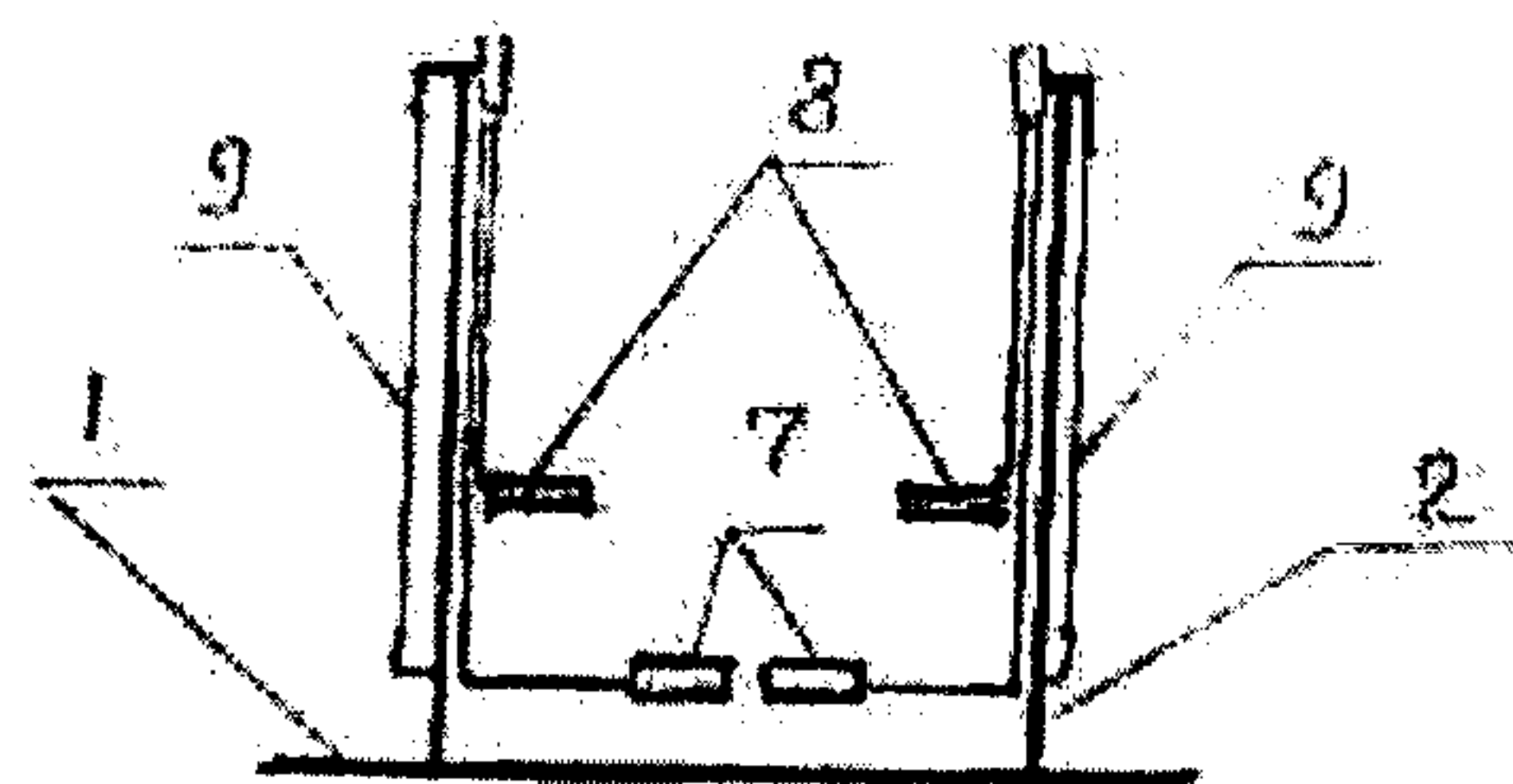

Fig 8

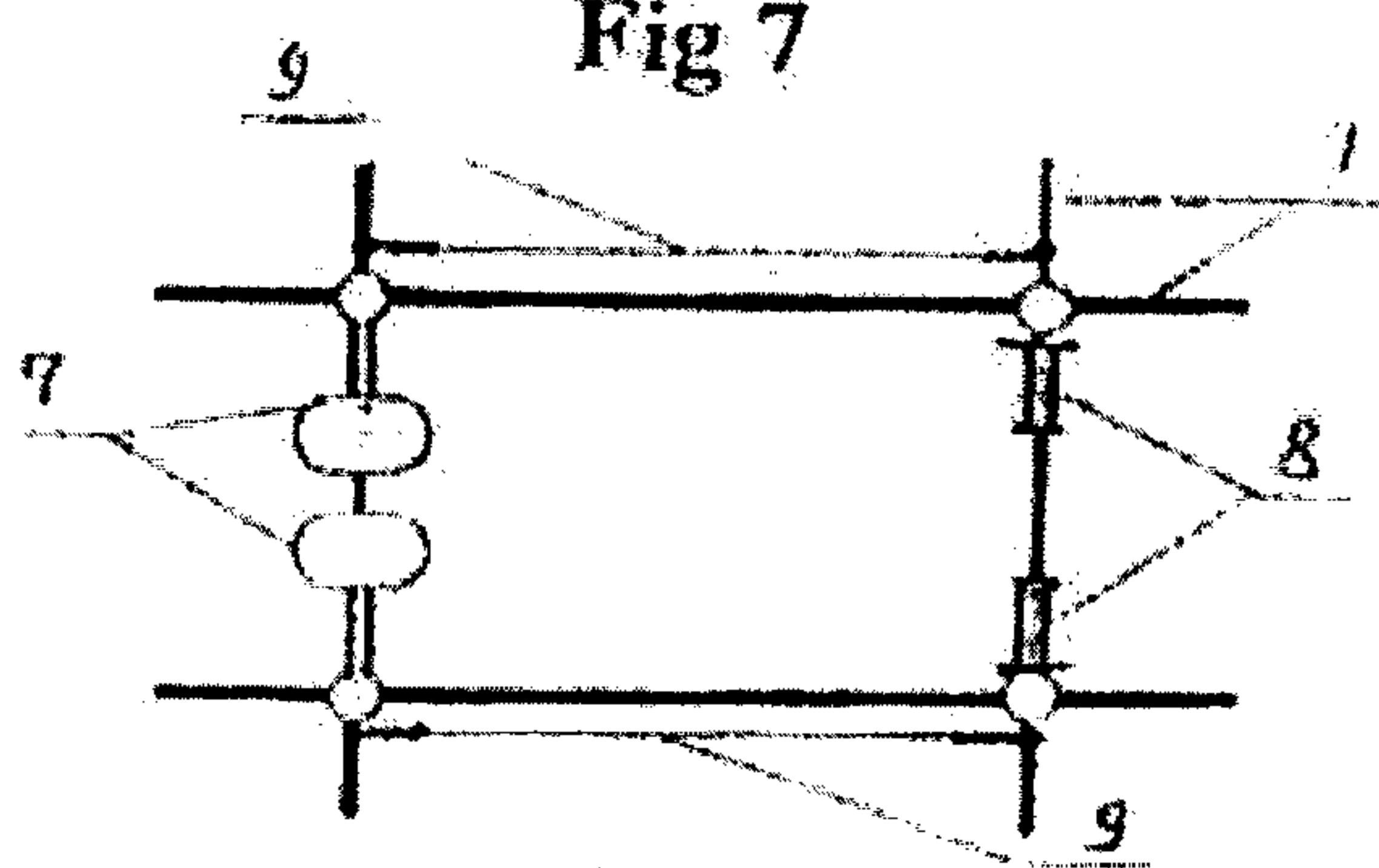

Fig 9

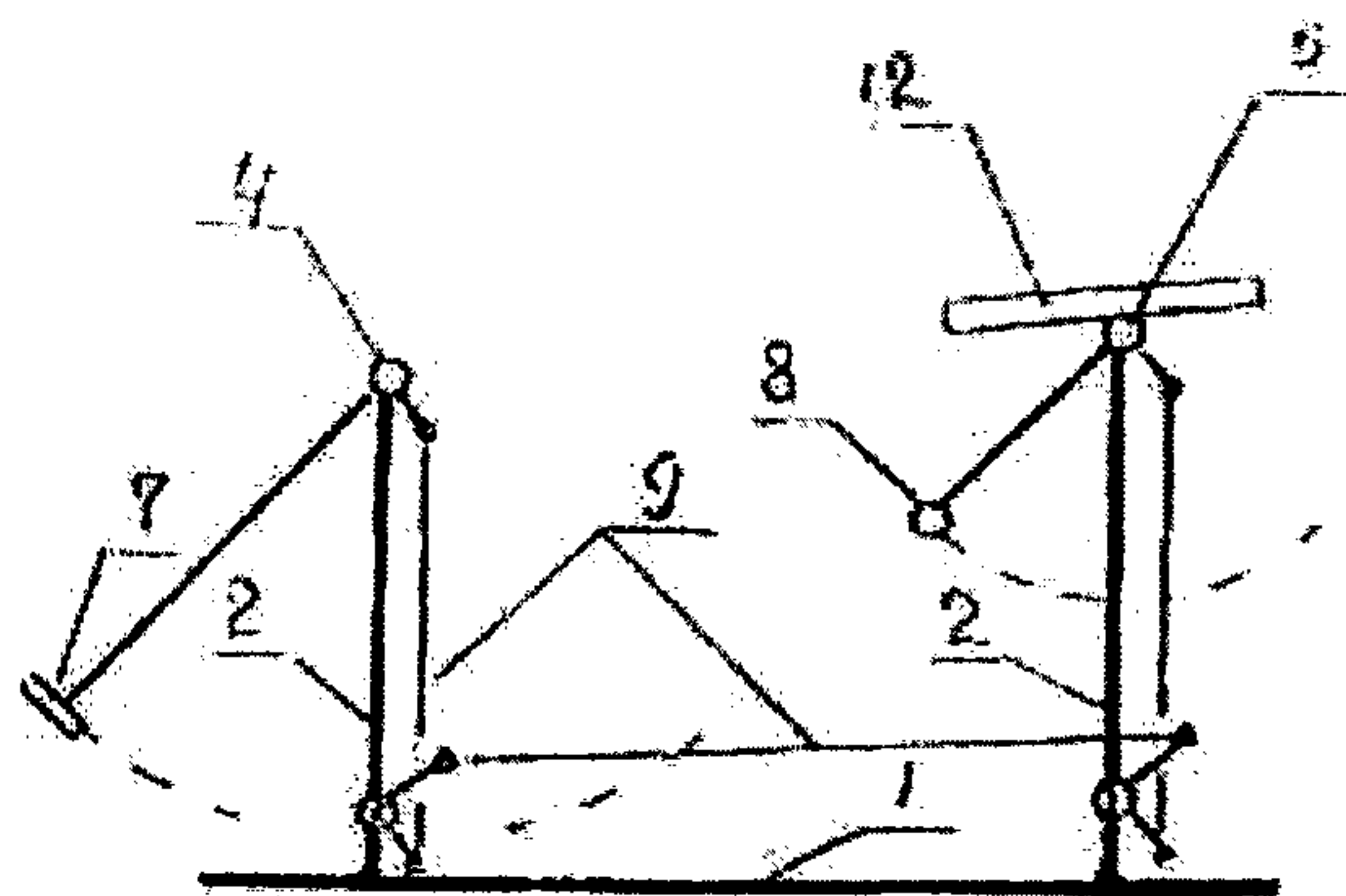

Fig 10

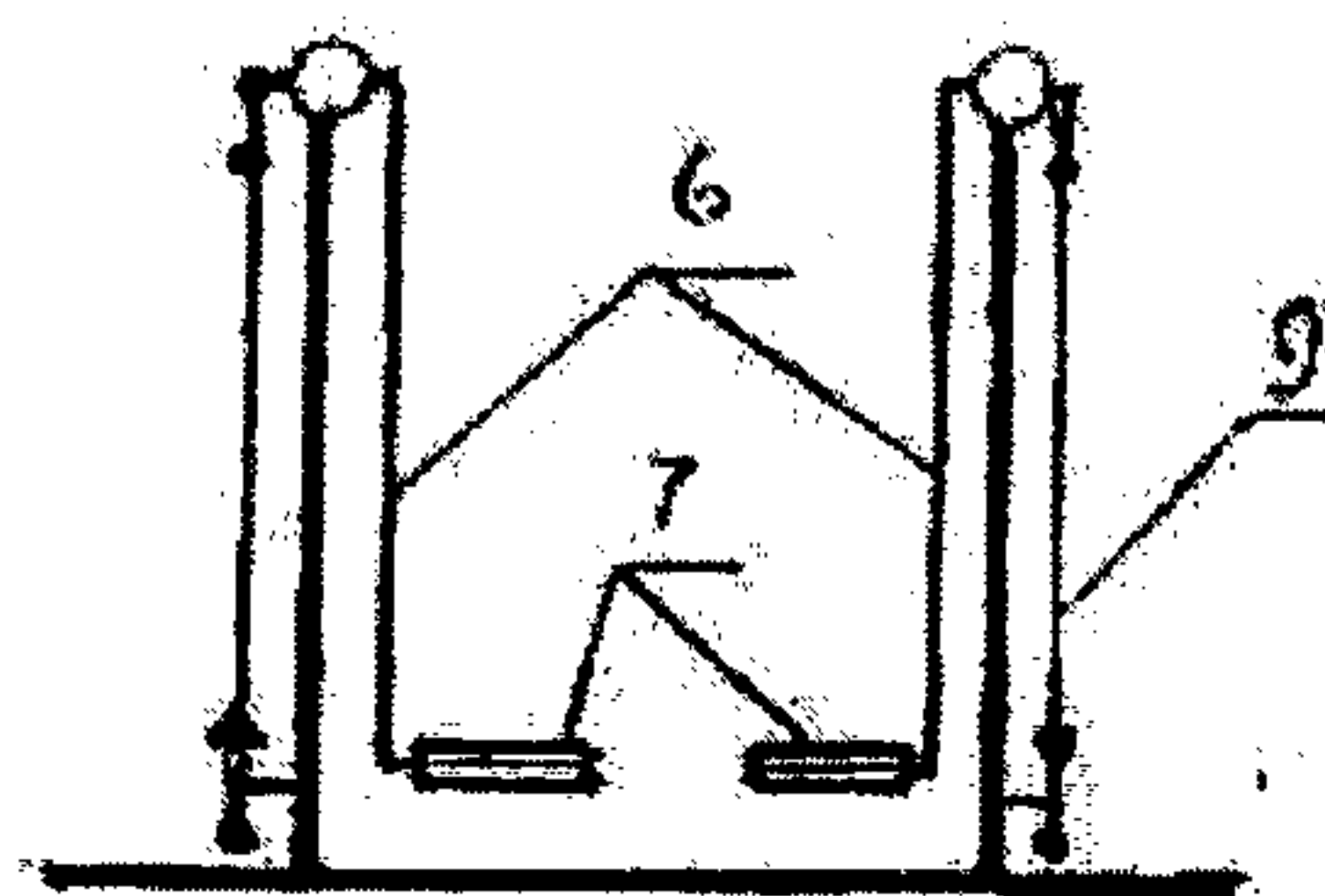

Fig 11

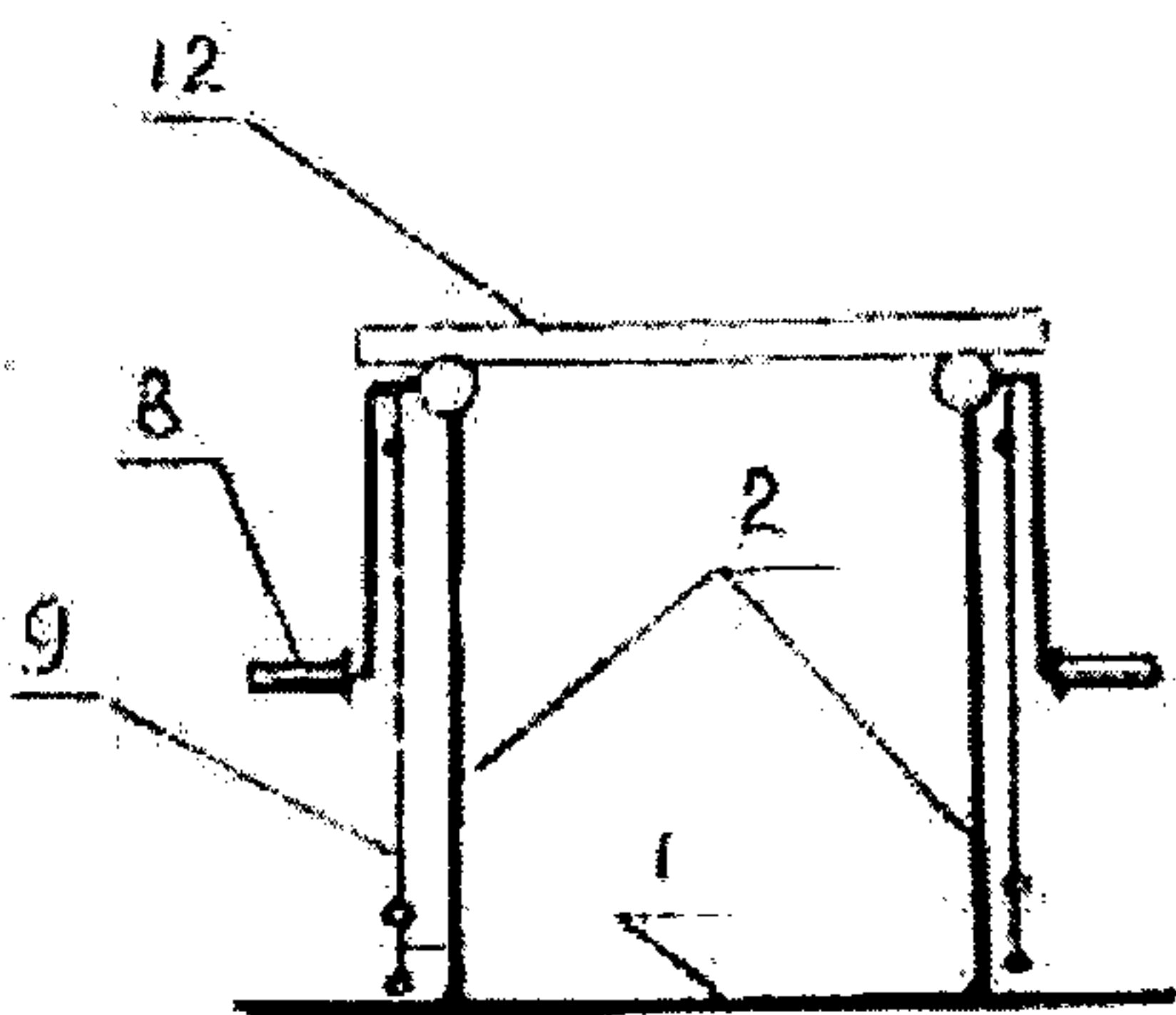

Fig 12

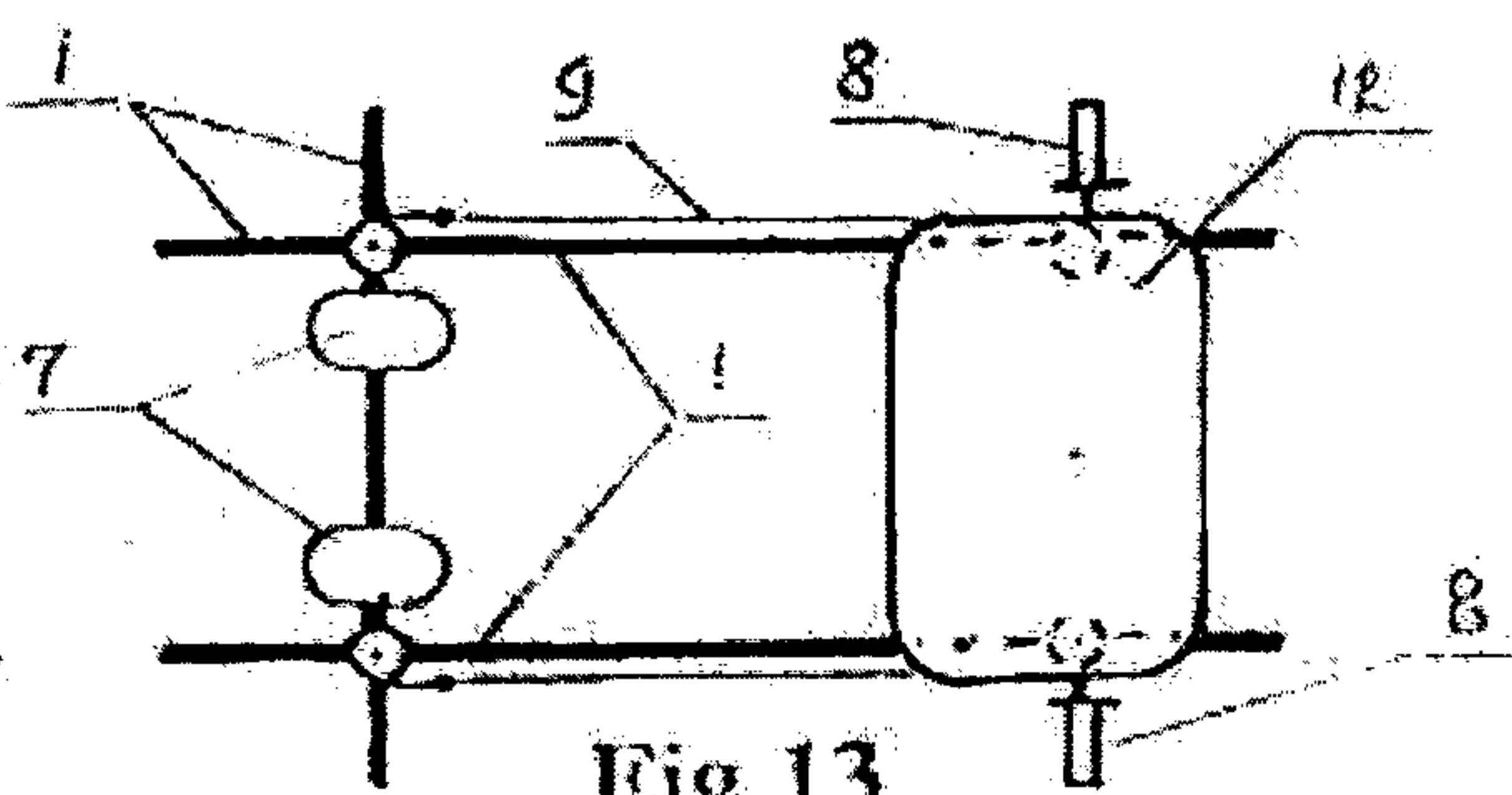

Fig 13

CARDIOVASCULAR SPINE EXERCISER
Z Akhmetov

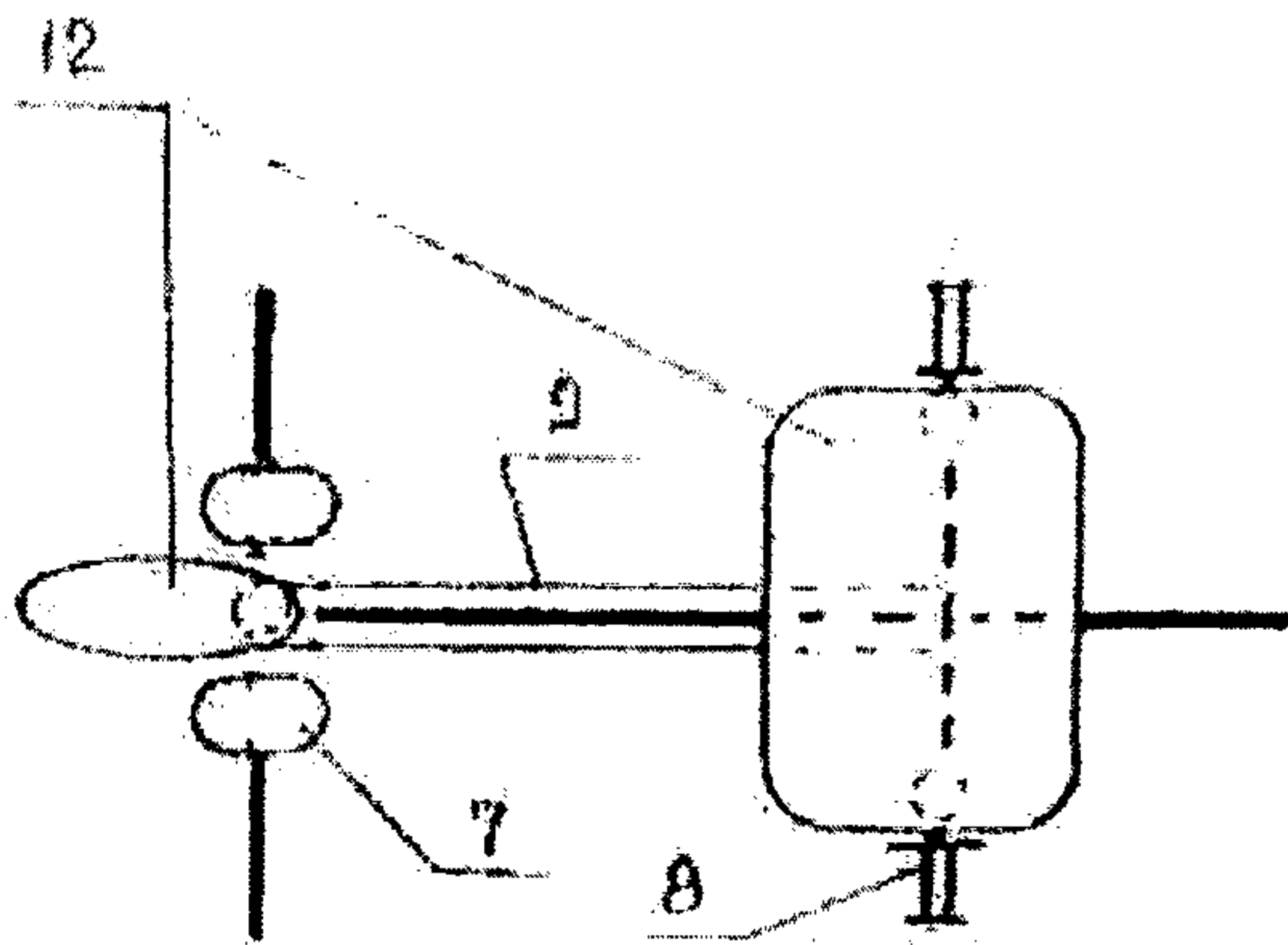

Fig 14

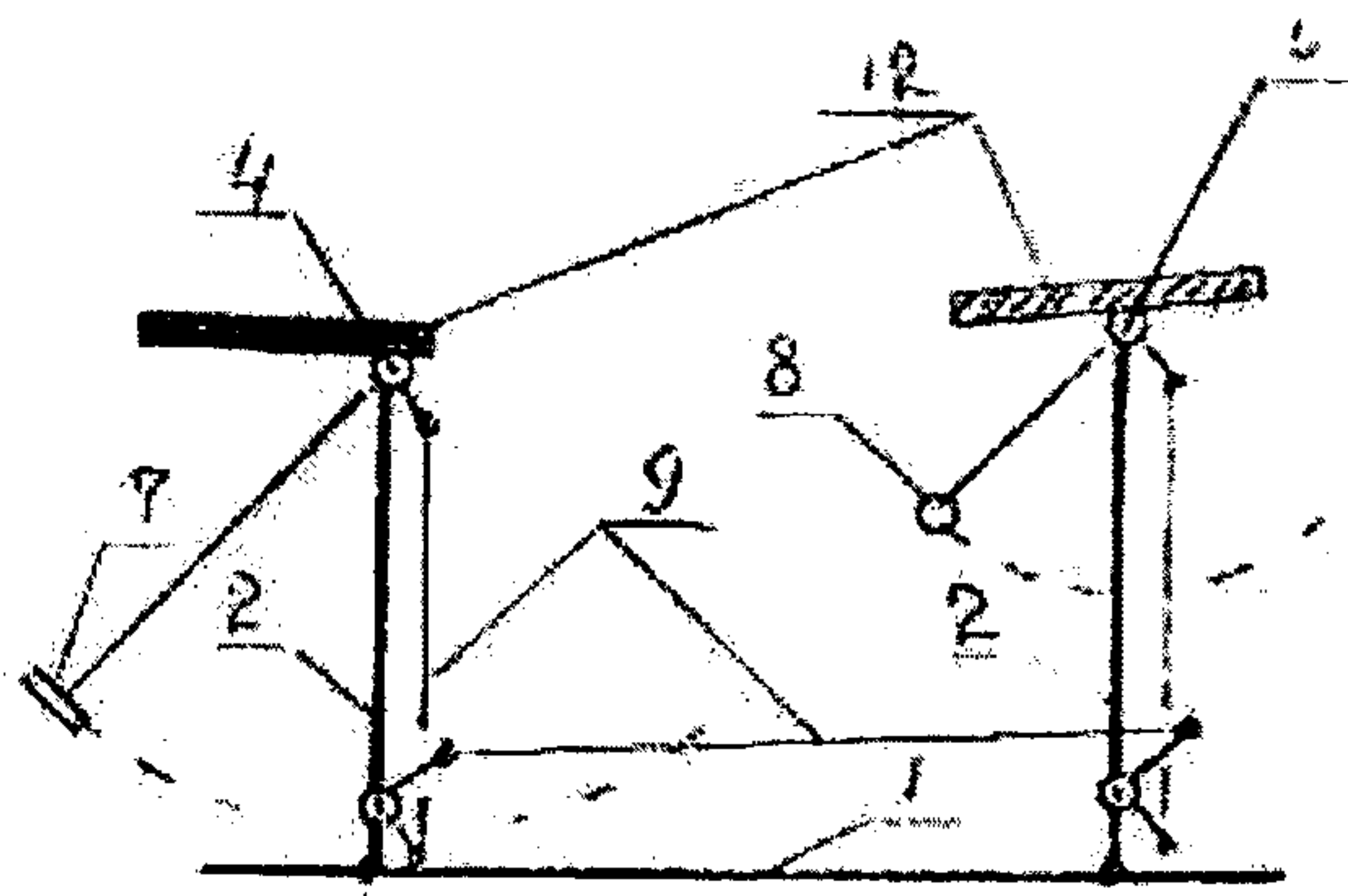

Fig 15

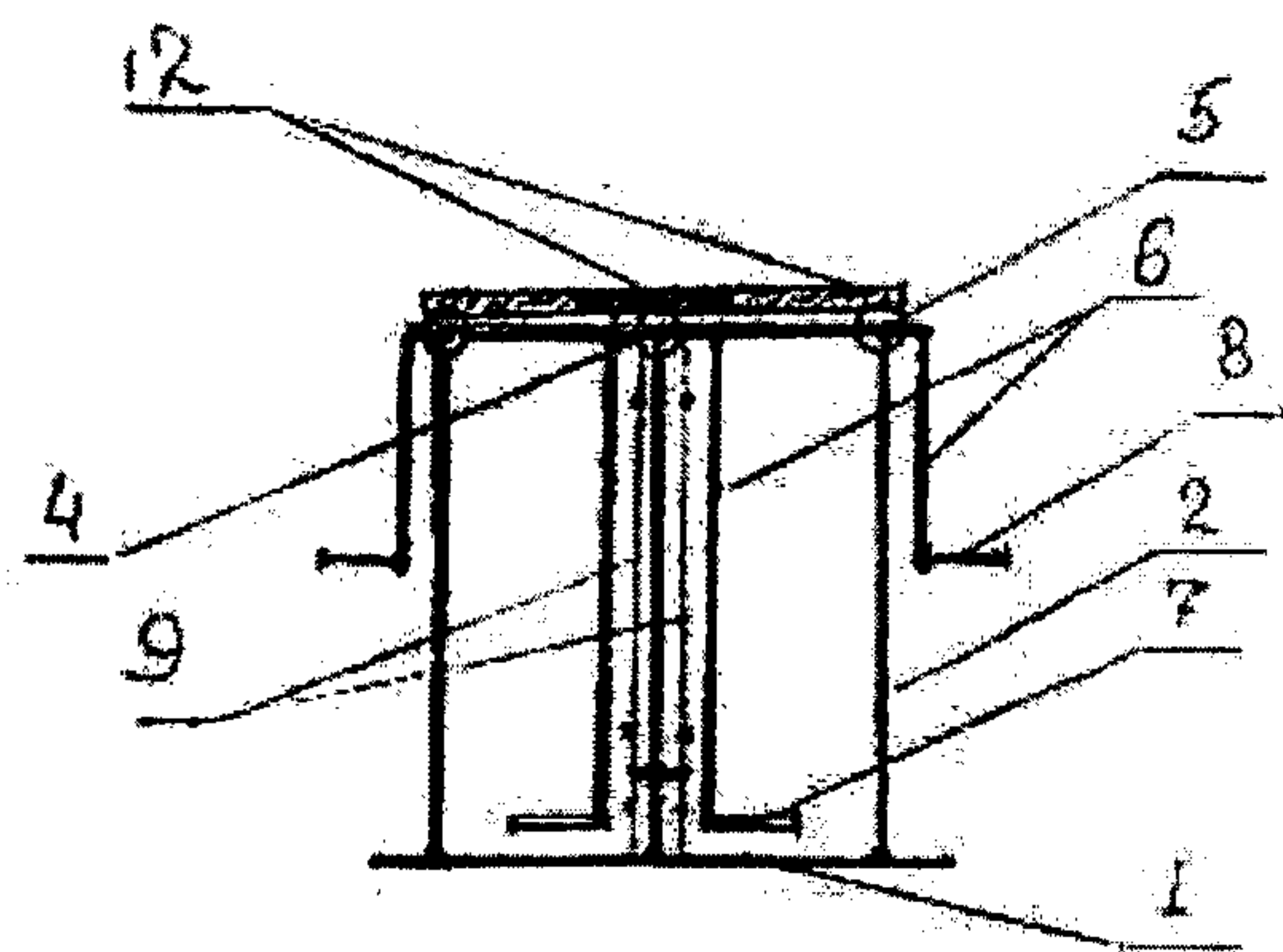

Fig 16

