

J. F. DIETZ.  
DESK LEAF SUPPORT.  
(Application filed Mar. 25, 1901.)

(No Model.)

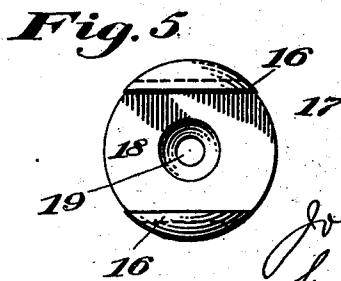
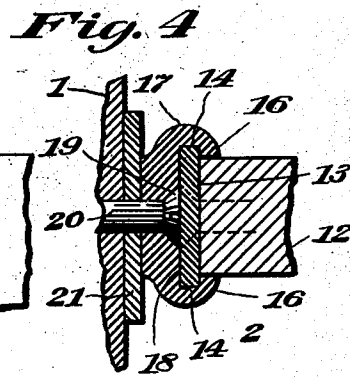
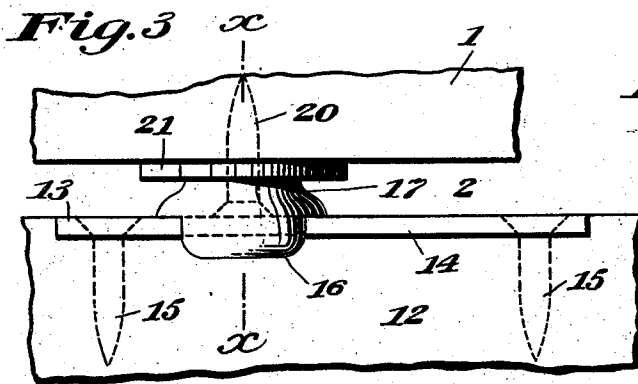
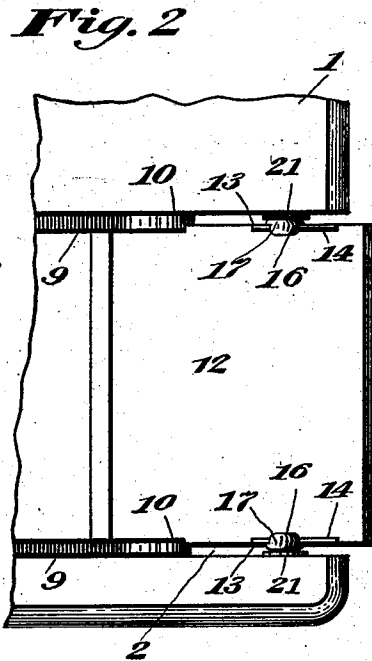
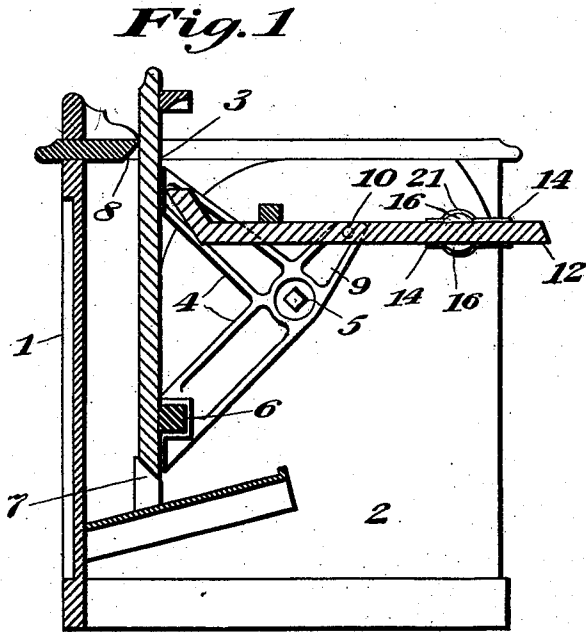

**Witnesses**  
*J. D. Thorne*  
*L. M. Jones*

**Inventor**  
*John F. Dietz*  
*by John Ellis Jones,*  
*his attorney.*

# UNITED STATES PATENT OFFICE.

JOHN F. DIETZ, OF CINCINNATI, OHIO.

## DESK-LEAF SUPPORT.

SPECIFICATION forming part of Letters Patent No. 695,545, dated March 18, 1902.

Application filed March 25, 1901. Serial No. 52,748. (No model.)

*To all whom it may concern:*

Be it known that I, JOHN F. DIETZ, a citizen of the United States of America, and a resident of Cincinnati, in the county of Hamilton and State of Ohio, have invented certain new and useful Improvements in Desk-Leaf Supports, of which the following is a specification.

This invention relates to certain improvements in desk-leaf supports, and especially in that class of such devices which are arranged to permit both sliding and pivotal movement of the desk-leaf when operated; and the object of the invention is to provide a device of this character of a simple and inexpensive nature and of a strong and durable construction adapted for firmly supporting and holding the desk-leaf and strengthening the structure, and which is not liable to become de-  
ranged or broken when in use.

The invention consists in certain novel features of the construction, combination, and arrangement of the several parts of the improved desk-leaf support, whereby certain important advantages are attained and the device is made simpler, cheaper, and otherwise better adapted and more convenient for use, all as will be hereinafter fully set forth.

The novel features of the invention will be carefully defined in the claims.

In the accompanying drawings, which serve to illustrate my improvements, Figure 1 is a sectional view taken vertically through a desk having a leaf provided with supports constructed according to my invention. Fig. 2 is a partial plan view of the desk seen in Fig. 1. Fig. 3 is an enlarged fragmentary view showing one edge portion of the desk-leaf with the support for the same. Fig. 4 is an enlarged sectional detail view taken through the leaf-support in the plane indicated by the line *xx* in Fig. 3. Fig. 5 is an enlarged detail view showing detached the rotative member of one of the leaf-supports.

In these views, 1 indicates as a whole the desk to which my improvements are applied, the desk herein shown being a type-writer cabinet, having an opening 2 produced in it, in which the leaf which is adapted for the support of a type-writing machine or the like is mounted for movement. The cabinet or desk 1 has an opening in its top correspond-

ing with the opening 2, and said opening in the desk-top is adapted to be closed or covered over by a movable section 3, held on arms 4, pivoted at 5 in the space or opening of the desk or cabinet. The movable section 3 of the desk-top carries a counterweight 6, and when in lowered position its lower edge, as seen in Fig. 1, is adapted to rest and be supported on a part 7, suitably arranged in the lower part of the space or opening 2. The rear edge of the opening in the desk-top is beveled, as shown at 8, to permit the beveled edge of the movable section 3 to snugly fit thereon when the said section 3 is raised to close said opening.

The arms 4 4 are cast in an integral piece in the form of a bell-crank, and with them is cast integrally forwardly-directed arms 9, which extend up along the side walls of the space 2, as seen in Figs. 1 and 2, and are pivotally connected, as shown at 10, with the desk-leaf 12 in such a way that when the movable section 3 of the desk-top is operated to lower it and uncover the space or opening or to raise said section and cover said space the desk-leaf 12 will also be operated and will have imparted to it both pivotal and endwise or sliding movement, the pivotal movement of said leaf serving to lower the rear part of said leaf, so that the machine rested upon it may be housed beneath the movable section 3 of the desk-top and the sliding or endwise movement of the leaf serving, when the leaf is raised, to bring the machine rested upon it into position for use to slide said leaf forward and protrude its front edge from the space or opening 2 of the desk or cabinet, so that the machine rested on the leaf may be conveniently operated. To support the forward portion of the desk-leaf 12 while permitting of such pivotal and sliding or endwise movements thereof, I provide at opposite side edges of the forward portion of the leaf supporting devices carried by the walls of the space or opening 2 of the desk or cabinet and arranged for engagement with the lateral edges of the leaf in such a way as to firmly support the forward part thereof and hold the leaf to the side walls of the space or opening 2, so as to prevent the leaf from falling and dropping the machine rested upon it down into the space or opening 2 of the desk

or cabinet. As herein shown, these supporting devices for the desk-leaf comprise metal guide-plates 13, secured upon the lateral edges of the leaf at the forward part thereon, 5 being held in place upon said edges by means of screws 15 or the like, passed through their ends and into the leaf and having their opposite upper and lower edge portions arranged to project beyond the upper and lower surfaces of the desk-leaf and arranged to be engaged by parts carried by the side walls of the space or opening 2 in such a way as to hold the opposite edges of the leaf to the said side walls while permitting free sliding movement of said leaf. The said parts which hold the edge portions of the desk-leaf 12 to the side walls of the space 2 are in the nature of rounded or circular plates or blocks 17 of metal, having on their outer surfaces, as shown in Figs. 3, 4, and 5, projections or arms 16, which are spaced apart from each other in such a way as to produce between them a straight guideway 18, the edges of which are undercut into the arms or projections 16 to receive the projecting portions 14 of the guide-plates 13 at top and bottom of the desk-leaf, as shown in Fig. 4. Each plate or block 17 is adapted for rotative movement, being formed with a central axial opening 19, 30 extended through it and through which is passed a screw 20, the head of which is countersunk in the floor of the guideway 18 at said opening 19, so as to permit the guide-plates 13 to fit flush against the outer surface of the block or plate 17 in the guideway. To render the movement of the block or plate 17 more easy and also to prevent wear of the parts, I provide a washer 21, held on the screw 20 between the rotative part and the side wall of the space or opening 2 in the desk or cabinet. 40

In operation it will be seen that when the movable section 3 of the desk or cabinet top is operated its movement will be communicated through the arms 4 and 9 to impart pivotal and endwise or sliding movements to the desk-leaf 12, so that the guide-plates 13, held on said leaf, are caused to move endwise through the guideways 18 of the rotative parts or members 17, which latter are also caused to move pivotally or turn upon their screws 20 in order to accommodate the pivotal movement of the desk-leaf. Thus it will be seen that the forward portion of the desk-leaf 12 is supported at all times and is at the same time made capable of free movement to permit it to be withdrawn rearwardly into the space or opening 2, and also to be lowered at its rear portion, so that the machine supported upon the leaf may be conveniently housed within the space or opening when the movable section 3 of the desk-top is in closed position. The undercut arms or projections 16 of the rotative part or member 17 also serve to grip the projecting upper and lower portions 14 of the guide-plates, so as to hold

the edge portions of the desk-leaf securely to the side walls of the space 2 and prevent the said side walls from spreading, as they might otherwise do. In this way the forward edge of the desk-leaf is held against falling downward, so that the machine cannot be dropped into the space or opening 2 of the desk. The adjacent surfaces of the arms or projections 16 are by preference separated very slightly from the upper and lower surfaces of the desk-leaf 12, so that there will be no liability of said arms or projections binding upon the leaf when the latter is moved between the arms. This spacing of the arms from the leaf is indicated by heavy black lines in Fig. 4. 70 75 80

From the above description it will be seen that the leaf-support constructed according to my invention is of an extremely simple and inexpensive nature and is especially well adapted for use, since it permits of securely supporting the forward portion of the desk-leaf without interfering in any way with the free movements of the same and also serves to strengthen the structure of the desk by holding the side walls of the space wherein the leaf is movable to the edge portions of the leaf itself. The device is also very strong, is noiseless in operation, and is not liable to be broken or to become disordered while in use. It will also be obvious from the above description that the improved leaf-support is capable of considerable modification without material departure from the principles and spirit of the invention, and for this reason I do not wish to be understood as limiting myself to the precise form and arrangement of the several parts of the device herein set forth. 85 90 95 100 105

Having thus described my invention, I claim—

1. In a desk-leaf support for desks and the like, the combination of a part held for pivotal movement upon the desk or other article near the outer edge thereof and having spaced arms extended from it to produce a guideway between them, the arms being undercut upon adjacent sides, and a leaf having a part projecting beyond the faces of said leaf, the edge portions of which part are gripped and engaged for sliding movement in the undercut portions of the arms of the rotative part substantially as set forth. 110 115

2. In a leaf-support, the combination of a part having spaced arms extended from it to produce a guideway between them and provided with a central perforation opening into the said guideway, the arms being undercut upon adjacent sides, a screw passed through said central opening for holding said part for free rotative movement upon a desk or the like and a desk-leaf having a flat slide-plate extended along its edge portion with parts projected above and below the upper and lower surfaces of the leaf, the said slide-plate having sliding engagement in said guideway 120 125 130

outside of the screw and having its project-  
ing parts engaged in the undercuts of the  
arms between which the guideway is pro-  
duced for holding the slide-plate against re-  
5 moval from the guideway and also for hold-  
ing the screw against endwise movement,  
substantially as set forth.

Signed at Cincinnati, Ohio, this 23d day of  
March, 1901.

JOHN F. DIETZ.

Witnesses:

JOHN ELIAS JONES,  
HOMER M. DANIEL.