

J. BURRELL.
Ore Amalgamator.

No. 34,238.

Patented Jan. 28, 1862.

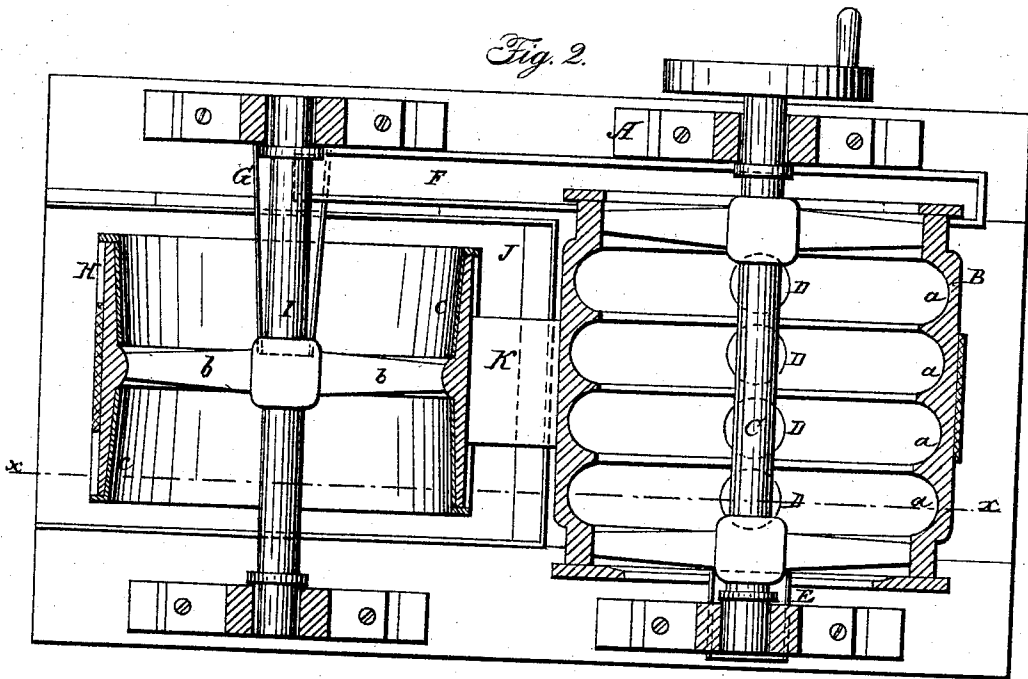
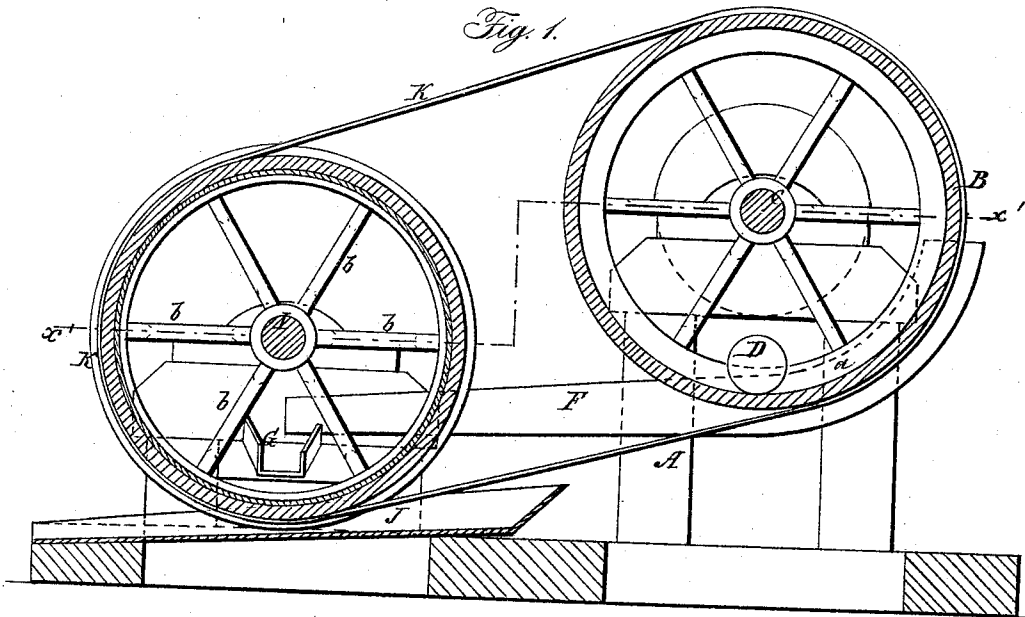

Witnesses:

J. W. Coombs
Wm. Simpson

Inventor:

James Burrell
per Wm. & Co.
Attorneys.

UNITED STATES PATENT OFFICE.

JAMES BURRELL, OF CENTRAL CITY, COLORADO TERRITORY.

IMPROVED AMALGAMATOR AND ORE-CRUSHER.

Specification forming part of Letters Patent No. **34,238**, dated January 23, 1862.

To all whom it may concern:

Be it known that I, JAMES BURRELL, of Central City, in the Territory of Colorado, have invented a new and Improved Pulverizer and Amalgamator for Separating Precious Metals from Ores; and I do hereby declare that the following is a full, clear, and exact description of the same, reference being had to the annexed drawings, making a part of this specification, in which—

Figure 1 is a side sectional view of my invention, taken in the line xx , Fig. 2; Fig. 2, a horizontal section of the same, taken in the line $x'x'$, Fig. 1.

Similar letters of reference indicate corresponding parts in the two figures.

The object of this invention is to obtain a machine which will complete the process of pulverizing the ore as it comes from the stamping-mills, and during the process of amalgamating the same, so that a more perfect separation may be obtained of the metal from the ore than by the ordinary amalgamating-machines.

The invention is chiefly designed for separating gold from quartz, and to receive the pulp as it is discharged from the ordinary stamp-batteries or stamping-mills.

The invention consists in the employment or use of a rotary or reciprocating pulverizer and amalgamator formed of a cylinder or semi-cylinder, provided with grooves which contain balls or spherical crushers, and using in connection therewith a rotary hollow cylinder or drum having an amalgamated inner surface, and so arranged as to receive the contents of the pulverizer and amalgamator, and separate any particles of gold that might have escaped amalgamation in passing through the pulverizer and amalgamator.

To enable those skilled in the art to fully understand and construct my invention, I will proceed to describe it.

A represents a framing, which may be constructed in any proper way to support the working parts of the machine, and B is a hollow cylinder, the shaft C of which is fitted in proper bearings on the framing A. This cylinder may be formed of cast-iron, and it is provided at its inner surface with a series of circumferential grooves, a , placed side by side

and of semicircular form in their transverse section. Each groove a contains a metal ball, D, the diameter of which corresponds with the width of its groove. The cylinder B is slightly inclined in the direction of its axis, and into the elevated end of the cylinder a trough, E, passes, said trough being secured to the framing A.

F is a trough or spout, which is inclined and is fitted longitudinally in the framing A, the upper end of the trough being curved, so that it may fit under the lower or discharge end of the cylinder B and receive its contents. The lower end of the trough F projects over the upper or elevated end of a small inclined trough, G, which is placed at right angles to F, and conducts the contents of the latter into a hollow cylinder, H, the shaft I of which is placed on the framing parallel to the shaft C of cylinder B. The cylinder H is provided with one set of arms b , and these are at the center of the cylinder. The inner surface of cylinder H is of copper or other metal having an amalgamated outer surface. The inner end of trough G projects over the center of cylinder H, the latter having a slightly flaring inner surface from its center outward in both directions, as shown at c in Fig. 2. Underneath the cylinder H there is placed a trough, J, which is wider than the cylinder, so as to receive its contents from both ends.

K is a belt which passes around the two cylinders B H.

The operation of the machine is as follows: The cylinder B is rotated by any convenient power, and the pulp from the stamping-mill passes into cylinder B through trough E, which is supplied with a requisite quantity of quicksilver. The pulp is acted upon in the grooves a by the balls D, and further reduced or comminuted, so as to admit of the particles of gold amalgamating with the quicksilver. The pulp passes through the cylinder B from groove to groove, and is discharged into the trough F, which conducts it to the trough G, the latter discharging it in the center of the cylinder H, from which it flows toward both ends of the cylinder, and is discharged into the trough J. Any particles of gold that might chance to escape amalgamation in cylinder B will be caught in cylinder H, and hence all will be

separated from the pulp and saved. Motion, it will be seen, is communicated to the cylinder H from the cylinder B by the belt K.

I would remark that the cylinder B, having a rotary movement, would be decidedly preferable to other motions. A reciprocating motion, however, might be given it, and a semi-cylinder, instead of a whole or entire cylinder, used.

Having thus described my invention, what I claim as new, and desire to secure by Letters Patent, is not, broadly, a rotating or reciprocating vessel provided with balls, irrespective of the construction and arrangement herein shown and described; but

1. A rotating or reciprocating pulverizer and amalgamator, B, when constructed with a series of circumferential grooves, *a*, each of which is provided with a ball, D, arranged as described.

2. In connection with the pulverizer and amalgamator B, constructed as described, the cylinder H, provided with an amalgamated inner surface, and arranged to operate conjointly with B, substantially as and for the purpose set forth.

JAMES BURRELL.

Witnesses:

A. J. VAN DEREN,
W. T. POTTER.