



Europäisches Patentamt
European Patent Office
Office européen des brevets



(11) **EP 1 083 254 A3**

(12) **EUROPEAN PATENT APPLICATION**

(88) Date of publication A3:
13.11.2002 Bulletin 2002/46

(51) Int Cl.7: **D04C 1/12, D07B 5/00,
D07B 7/14**

(43) Date of publication A2:
14.03.2001 Bulletin 2001/11

(21) Application number: **00307726.0**

(22) Date of filing: **07.09.2000**

(84) Designated Contracting States:
**AT BE CH CY DE DK ES FI FR GB GR IE IT LI LU
MC NL PT SE**
Designated Extension States:
AL LT LV MK RO SI

(72) Inventors:
• **Witherell, Kenneth W.**
Charlotte, NC 28277 (US)
• **Ivarsson, Klas Ture**
429 31 Kullavik (SE)

(30) Priority: **07.09.1999 US 152824 P**

(74) Representative: **Smith, Samuel Leonard**
J.A. Kemp & Co.,
14 South Square,
Gray's Inn
London WC1R 5JJ (GB)

(54) **Pull cord for blinds and method of making same**

(57) A method of manufacturing a control cord (27) for use in a covering for architectural openings includes the steps of providing spools (10) of high tensile strength and low abrasion characteristic yarns (12), tensioning the yarns (12) and winding the yarns (12) under tension on bobbins (20), placing the bobbins (20) in a braiding apparatus (26) and making an eight-carrier braid from the yarns (12) on the bobbins (20), and passing the braided cord (27) through a treatment apparatus (30) where a urethane coating is applied to the cord (27) and heat cured.

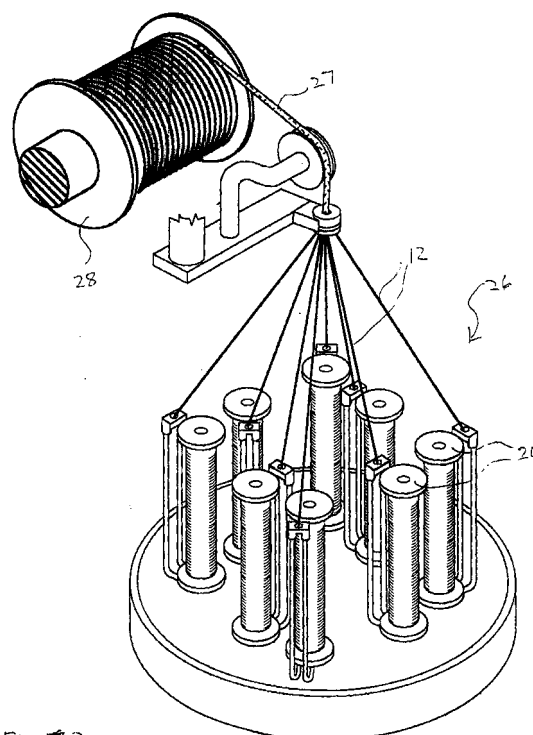

Fig. 3

EP 1 083 254 A3



European Patent
Office

EUROPEAN SEARCH REPORT

Application Number
EP 00 30 7726

DOCUMENTS CONSIDERED TO BE RELEVANT			
Category	Citation of document with indication, where appropriate, of relevant passages	Relevant to claim	CLASSIFICATION OF THE APPLICATION (Int.Cl.7)
A	DATABASE WPI Section Ch, Week 198715 Derwent Publications Ltd., London, GB; Class A28, AN 1987-105601 XP002213276 & JP 62 053495 A (TEIKOKU SANGYO K.K.), 9 March 1987 (1987-03-09) * abstract *	1,2	D04C1/12 D07B5/00 D07B7/14
A	PATENT ABSTRACTS OF JAPAN vol. 1997, no. 05, 30 May 1997 (1997-05-30) & JP 09 021044 A (TOYOKA CO. LTD.), 21 January 1997 (1997-01-21) * abstract *	1,2	
			TECHNICAL FIELDS SEARCHED (Int.Cl.7)
			D04C D07B E06B
The present search report has been drawn up for all claims			
Place of search		Date of completion of the search	Examiner
THE HAGUE		12 September 2002	Goodall, C
CATEGORY OF CITED DOCUMENTS X : particularly relevant if taken alone Y : particularly relevant if combined with another document of the same category A : technological background O : non-written disclosure P : intermediate document T : theory or principle underlying the invention E : earlier patent document, but published on, or after the filing date D : document cited in the application L : document cited for other reasons & : member of the same patent family, corresponding document			

EPO FORM 1503 03/82 (Pof/c01)

**ANNEX TO THE EUROPEAN SEARCH REPORT
ON EUROPEAN PATENT APPLICATION NO.**

EP 00 30 7726

This annex lists the patent family members relating to the patent documents cited in the above-mentioned European search report. The members are as contained in the European Patent Office EDP file on
The European Patent Office is in no way liable for these particulars which are merely given for the purpose of information.

12-09-2002

Patent document cited in search report		Publication date	Patent family member(s)	Publication date
JP 62053495	A	09-03-1987	NONE	
JP 09021044	A	21-01-1997	JP 3298370 B2	02-07-2002

EPO FORM P0459

For more details about this annex : see Official Journal of the European Patent Office, No. 12/82