

June 11, 1968

C. A. CRAFTS ET AL

3,387,606

INDUCTIVE SIGNAL TRANSFER DEVICE, USEFUL FOR AVIATORS' HELMETS

Filed March 12, 1962

FIG. 1

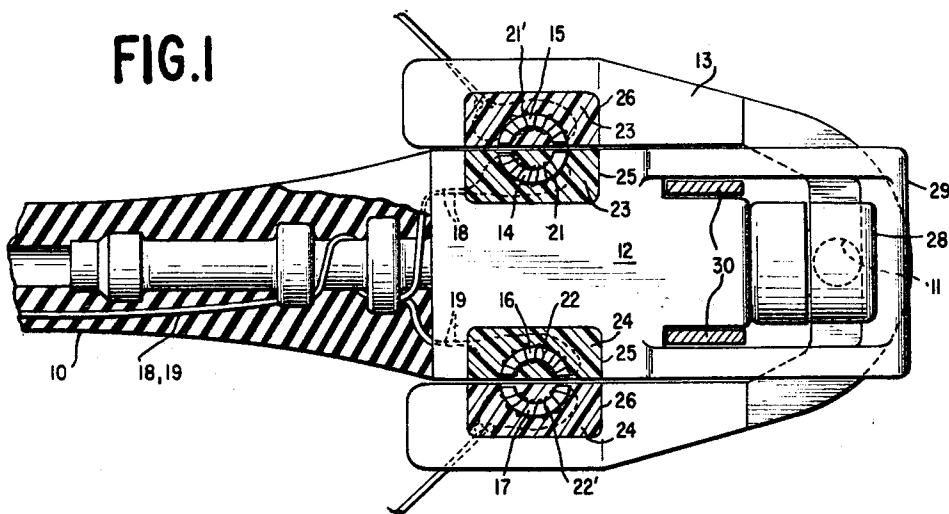

FIG. 2

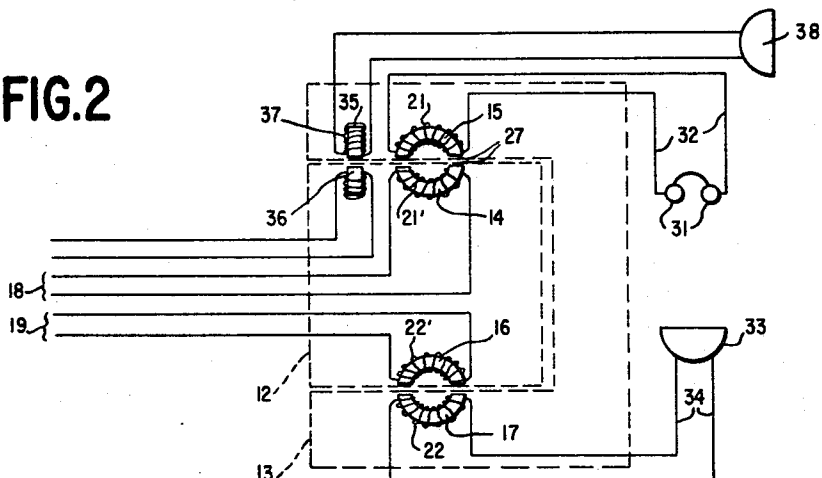
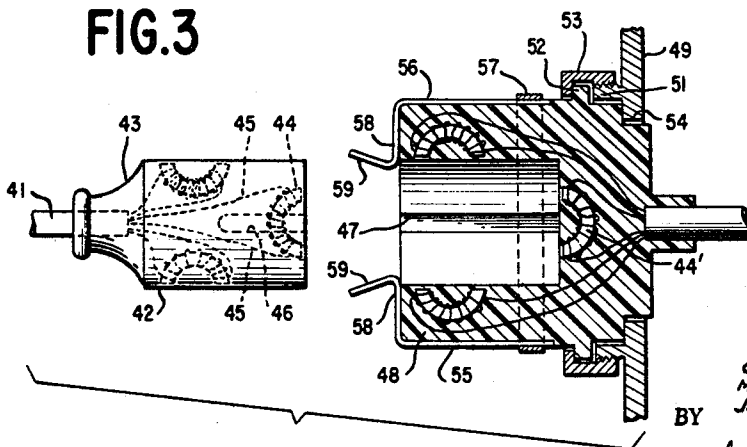

FIG. 3



INVENTORS  
CECIL A. CRAFTS  
MAYNARD D. Mc FARLANE  
JOHN E. MITCHELL  
BY  
*Mead, Brown, Schuyler & Beveridge*  
ATTORNEYS

1

3,387,606

**INDUCTIVE SIGNAL TRANSFER DEVICE,  
USEFUL FOR AVIATORS' HELMETS**

Cecil A. Crafts, Santa Ana, Maynard D. McFarlane,  
Tustin, and John E. Mitchell, Costa Mesa, Calif.,  
assignors to Robertshaw Controls Company, Rich-  
mond, Va., a corporation of Delaware

Filed Mar. 12, 1962, Ser. No. 178,980

9 Claims. (Cl. 128—141)

This invention relates to inductive signal transfer devices and more particularly to their use in combination with an oxygen supply connection to a mask or helmet in a unitary quick disconnect arrangement which avoids the use of metal to metal contacts.

Astronauts and pilots of military aircraft in the upper atmosphere require a helmet or mask for the control of the oxygen or air supply to the pilot and, at the same time, require connections which can be quickly made or broken in the event it becomes necessary for the pilot to be quickly separated from the craft. Similarly, a diver may require a helmet with an oxygen supply and a communication system associated therewith which may be broken away from the helmet by a single unitary quick disconnect device capable of instantaneous action. It has previously been known to combine with a quick disconnect arrangement for an air supply, a plurality of electrical plugs and sockets each making connection with one circuit in a helmet and with an external circuit. An example of a combined quick disconnect oxygen supply with electrical interconnections between the helmet and external circuitry employing standard jacks and receptacles as illustrated in the patent to R. E. Darling, No. 2,634,311. A disadvantage has been found to result in such a structure from the exposed position of the metal contacts which are subject to surface leakage under conditions of moisture condensation, salt spray and immersion. Under vibration the relatively heavy structure of the components on which the plug and jack are mounted may cause intermittent contact between the plug and jack with the result that communication between the pilot and the remainder of the system is interrupted or is given false or misleading signals. The rather large size of such a structure is also a disadvantage.

It has also been proposed that detachable connections be made between a power supply and another circuit by way of an inductive coupling as in the case of the patent to B. Easton, No. 2,483,815. This patent employs a transformer primary and secondary, one concentric within the other in which it is possible to connect the parts of but one circuit. Such signal inductive transfer devices have not heretofore been applicable to the use of several independent circuits combined within a single plug-in member without the resultant intermixing or cross talk of the signals in the several circuits. It has likewise not been previously possible to combine a multi-circuit interconnection device employing inductive transfer with a quick disconnect feature such as is essential in the interconnection of the pilot's helmet or mask with external circuitry and his oxygen supply.

It is accordingly an object of this invention to provide an insulated plug-in type of electrical signal transfer device for use in oxygen supply quick disconnect service.

A further object of the invention is to provide a combined quick disconnect electrical connection for a plu-

2

rality of circuits and an oxygen supply quick disconnect connection in one unitary assembly.

A further object is to provide an induction signal transfer device for a plurality of circuits assembled in a single plug-in unit having no exposed electrical contacts subject to corrosion or shorting by atmospheric moisture.

A still further object of the invention is to provide an inductive signal transfer device for a plurality of circuits where cross talk between the circuits is eliminated.

In achieving these objects this invention utilizes paired transformer core elements in plug and receiver portions, one for each circuit to be established. Adjacent pairs of flux controlling cores are closely spaced but disposed to avoid cross linking flux. Each core and winding is embedded in plastic or the like to present a fully insulated exterior.

Other objects and features of the invention will be understood as the invention is explained by reference to the following drawings in which:

FIG. 1 is a schematic view of a quick disconnect oxygen supply hose connection combined with inductively coupled electrical connections for the pilot's communication system.

FIG. 2 is a schematic diagram of a portion of a plug and receptacle of FIG. 1, illustrating in detail the circuit connection between ear phones, microphones and external circuits, and

FIG. 3 illustrates an alternative form of a signal transfer device for a plurality of circuits, employing a plug and receptacle suitable for headwear use in which cross talk between circuits is avoided by a further arrangement of the respective cores of the signal transfer devices.

Referring now more particularly to FIG. 1 there is illustrated at 10 an oxygen supply hose connected to a supply (not shown) such as might be contained in the aircraft in which the pilot is operating. An oxygen outlet to the mask or helmet of the pilot is indicated at 11 as a tubular portion of the receiver portion of the quick disconnect fixture. The hose member 10 preferably terminates in a plug member 12 which may be of rectangular form having plane surfaces at the upper and lower sides thereof as viewed in FIG. 1, suitable for close fitting insertion in a receiver 13 to which the hose member 10 is to be connected by way of the plug member 12, thereby to provide a continuous oxygen supply from 10 to 11. Details of such a quick disconnect feature in the oxygen supply for a helmet are disclosed in patent application Ser. No. 166,565 filed Jan. 16, 1962, by John E. Mitchell and Lloyd L. Bissing, assigned to the common assignee with the present application. Since these features do not form a part of the present invention they will not further be described here except to note that an arrangement is provided which connects the two hose portions in airtight relationship to withstand the pressure of the oxygen system and at the same time to provide means for instantaneously disconnecting the plug and receiver members.

The copending application employs metal to metal contacts in the faces of the plug member 12 and the receiver member 13 adjacent thereto. According to the present invention an arrangement is provided for replacing the metal to metal contacts with inductive signal transfer arrangements employing transformer core halves 14 and 15, disposed one in the plug member and the other in the re-

ceiver member immediately adjacent thereto when the plug member is seated within the receiver member. At the opposite face of the plug member 12 is disposed a transformer core half 16 and immediately adjacent thereto is the complementary member 17 in the receiver member, each such core member being wholly within the member and so positioned that when the quick disconnect device is assembled the magnetic circuit between core members 14 and 15 and between members 16 and 17 is substantially closed. Leads 18—18 and 19—19 correspond each to a circuit extending into the plug member and connecting with opposite terminals of windings 21 and 22 on the corresponding primary core members 14 or 16.

In order that the signal transfer apparatus thus far described shall be completely free of atmospheric shorting or corrosion it is preferable that the assembled core and winding shall be embedded or potted in a plastic block as at 23 and 24, preferably formed by casting. One core and winding may be placed in the plug pocket 25 and another in receptacle pocket 26 in a position to leave each of the core end 27 lying immediately beneath the surface as the block is cast thereover. It will be understood that such a construction permits the finishing of the surface above the core ends 27 as may be required to cause a proper fit between the plug member 12 and the receiver member 13.

As more fully disclosed in the copending patent application the plug member is engaged within the receiver member and firmly held in that position by means of a retaining hook on the receiver member as at 28 and a retaining bail 29 attached to the plug member. When the bail is passed over the hook and the plug 12 is pressed into the receiver member 13 it may be locked into position by a lever 30 to establish the airtight connection desired and, at the same time, hold corresponding core ends 27 in position adjacent each other, separated only by a thin section of the plastic block respectively surrounding each such core member.

In FIG. 2 there are shown portions of members 12 and 13 in section, respectively, with core members 14, 16, 15 and 17 in position to substantially complete magnetic circuits therebetween to permit signal transfer by induction. Winding 21 is connected to ear phones 31 by way of the leads 32 and winding 21' is connected to an external circuit by way of the leads 18. Similarly the winding 22 is connected to a microphone 33 by way of leads 34 and winding 22' is connected to the external circuitry by way of leads 19.

For some purposes it may be desirable to have a third communications circuit to the helmet of the aviator. A second microphone may be connected to a further receiver core 35 and thence to a corresponding core 36 on the plug. Winding 37 on the core 35 extends to microphone 38 and corresponding leads and winding on the core 36 extends to circuitry within the airplane.

Such a third signal transfer device might be used, for example, with a second microphone or other device as at 38, which might connect to a second signal output from the pilot, going by internal craft connections to a copilot. The microphone 33 might be of the dynamic type in which a sound powered diaphragm and signal generator furnishes current inductively coupling windings 22 and 22' thence extending to the aircraft communication system by means of leads 19. Either microphone 38 or 33 might be of the carbon button type or of any other construction employing a small battery to provide a current which is modulated by the action of the microphone in order to provide a more adequate signal to be coupled to the external communication system.

Since two magnetic circuits in closely spaced relation have a tendency to interact under conditions of varying excitation, as in communications, precautions are required to minimize the flux linkage from one transformer core to another. Considering the plug member 12 the contained cores 14 and 16 are oppositely disposed to mini-

mize flux therebetween both by separation of pole pieces 27 and by orientation. In a third closely spaced transformer the cores 35 and 36 may be disposed at right angles to the cores 14 and 15, or to 16 and 17 such that any leakage flux is at right angles rather than parallel to the core structure which might otherwise gather a portion thereof to induce cross coupled signals.

Such an embodiment of the invention as has previously been described is particularly adapted for use with a helmet-mounted oxygen supply connection of the quick disconnect type, but is not so limited in its application. This arrangement may be employed in a diver's helmet, a bathysphere, or in any other similar arrangement in which it is necessary to pass signals through an outer wall into an inner container without the use of metal to metal contacts such as could be shorted by immersion in water or by atmospheric moisture conditions.

One arrangement might include a diver's or radiation monitor's helmet to which a connection must be made after the helmet is placed on the wearer's head but which is quickly removable for washdown or in order to give mobility to the wearer, yet making possible the interconnection of the circuitry to and from his communication system without the use of exposed contacts of any type. A cable 41 for this purpose might include a number of signal leads all enclosed within a waterproof rubber or plastic covering which connects to a plug member 42 by means of a fairlead arrangement 43 protecting the cable against chafing or breaking at the connection point.

Plug member 42 in this version may be of cylindrical form in which corresponding core halves as at 14 and 16 of FIG. 2 are employed each with its winding thereon connecting to the leads within the cable 41. Such core members are disposed within the plug member in a position to exactly match the position of the corresponding core halves 15 and 17 disposed within the outer walls or lateral projections of the receiver and socket member 48, generally in the manner illustrated in FIG. 2, except that orientation is now required between the cylindrical plug and receptacle members so that the corresponding core halves will be oppositely disposed for maximum transfer of signal.

Such a connector may also conveniently employ a third core 44 like core 35 but disposed in the end of the plug member to cooperate with a similar core 44' in the end of the socket member for the transfer of a third set of signals.

Placing the plane of cores 35 and 36 at right angles to nearby cores 14 and 15 has been described as a necessary measure to minimize cross talk between circuits. In the arrangement shown in FIG. 3 the break in the magnetic circuit for core 44 is at right angles to the plane of the break for the core 14 or 16, and leakage flux paths of the respective cores are at right angles thereby to prevent any substantial degree of flux linkage between the third and the first or second transfer devices.

The plug member 42 is preferably supplied with a key portion 46 along one face thereof which fits within a slot 47 in the corresponding face of the receptable member 48 such that when the two are placed in key-oriented operative position this position is maintained with certainty and exactitude. The socket member is preferably attached to a helmet or enclosure wall at 49 by means of attached nipple 51, collar 52 and nut 53. Internal connections pass from the socket member through a hole 54 in wall 49 to leave an airtight enclosure through which signals pass without use of exposed metal electrical inserts or contacts.

It is desirable to maintain a close friction fit between the plug and socket members of FIG. 3, but not to rely exclusively upon friction to prevent relative axial motion. Spring clips 55 and 56 are appropriately secured to the socket member along two or more opposed sides thereof by means of retaining ring 57 and/or slots according to the method of manufacture most convenient. Clips 55

and 56 have turned in portions 58 arranged to overlie the outer end of the plug member when in place and retain it in that position, and have sloped portions 59 adapted to ride over the plug as it is inserted.

While the invention has been described in connection with particular embodiments it will be understood that other embodiments and equivalents are contemplated within the scope of the appended claims.

What is claimed is:

1. A signal transfer device for quick disconnect service interconnecting a plurality of separated circuits,
  - a first transformer having a secondary core member and winding entirely imbedded within a plastic receptacle wall,
  - a primary core and winding entirely imbedded in a plastic plug unit adapted to be fitted within said receptacle,
  - said plug and receptacle units being keyed for engagement in predetermined alignment,
  - said core members being substantially of C-form and of size and disposition within said plug and receptacle units, when aligned, to substantially complete a high permeability magnetic path through said primary and secondary core members,
  - a second transformer having primary and secondary core members each with a winding thereon entirely imbedded within receptacle and plug units, respectively, said core members being oriented at least 90° from the core members of the first transformers for reduction of magnetic intercoupling therebetween, and
  - signal transmit-receive means connected to said windings of said first and second transformers for the conveying of separate signals therethrough in a plurality of circuits.
2. In a quick disconnect fixture for unitary oxygen hose and communication connections to headgear the combination of,
  - an oxygen supply line terminating in a plug member, an oxygen receiver member on said headgear, quick disconnect means connecting said plug and receiver members in fluid tight relation,
  - a first signal transfer means including matched transformer core portions in juxtaposition one in said plug member and one in said receiver member, said core portions being substantially of semicircular shape, each having thereon an energizing winding, one to generate when electrically energized flux variations through both said portions and the other to generate voltage signals by induction in response to said flux variations,
  - a second signal transfer means generally like the first and including transformer core portions and windings being disposed with ends of said core portions of said plug member terminating in directions separated substantially at least 90°,
  - impregnating means covering said core and windings of each signal transfer means and extending to form predetermined spacing between said core portions of each said transfer means,
  - and key means orienting and retaining said matched core portions in said fixed juxtapositional relation.
3. In a helmet for supplying oxygen and communications to an aviator,
  - oxygen hose supply means including a termination for connection to said helmet,
  - receiver means detachably holding said termination in fluid tight relation to said helmet,
  - a plug member of rectangular section enclosing said termination,
  - a receiver member of dimensions to enclose laterally said plug member in fixed closely spaced relationship,
  - a pair of split transformer core portions in said plug member having ends thereof disposed each immedi-

ately beneath a lateral surface of said plug member, a pair of complementary core portions one for each prior said pair and having ends thereof disposed each within an inner face of said receiver member in position for substantially completing in each case a transformer core when in said fixed relationship, signal transfer windings on each said core portion, means insulating the exterior surface of said plug and receiver members to prevent sparking during disconnection thereof in the presence of oxygen, and signal generating and utilization means connected respectively to said windings completing signal transfer means to and from said helmet.

4. A signal transfer device for quick disconnect service comprising,
  - a cylindrical plug member,
  - a cylindrical receptacle member dimensioned to receive said plug member in fitted relationship,
  - key means on each said member cooperating to retain orientation therebetween when said plug member is within said receptacle member,
  - a first split circular magnetic core, half within said plug member and half within said receptacle member being disposed when in said orientation to substantially complete a magnetic path between said halves,
  - a second split core disposed as the first to complete a similar magnetic path and being at opposite sides of said plug and receptacle members from first said core for minimizing flux linkage therebetween,
  - a third split core disposed half within said plug at an inner end thereof and half within said receptacle member with the split core ends in respective juxtaposition when in said orientation,
  - and induction windings on each core half for transferring signals to and from said plug member and said receptacle member in three magnetically and electrically separate circuits.
5. The combination of claim 4 wherein each said core and winding thereon is enclosed within a plastic pocket in one said member.
6. A signal transfer assembly for quick disconnect service for a plurality of simultaneous signals without exposed intervening contacts comprising,
  - a cylindrical plastic plug member including therein a plurality of split magnetic core members of C shape each having a pair of ends terminating immediately beneath one surface of said plug member, the respective members being disposed in opposed relation for minimizing magnetic linkage therebetween,
  - a cylindrical plastic receptacle member having a similar plurality of split core members complementary to first said members and arranged with corresponding core ends in juxtaposition to said ends, respectively, in said plug member, when the plug member is seated in fixed orientation therein,
  - primary and secondary windings on each pair of juxtaposed core members for inductively transferring separate signals in each said pair of windings,
  - and means connecting signal transducer means to the respective primary and secondary windings for each said pair of core members.
7. An assembly according to claim 6 wherein two said cores of the plug member are at sides of the cylindrical plug member not substantially less than 90° apart.
8. An assembly according to claim 6 wherein one said core member terminates within an inner end of said plug member and at least one said core member terminates within and at a lateral side of said plug member.
9. An assembly according to claim 6 wherein three said core members have terminations oriented at least 90° one from another.

## References Cited

UNITED STATES PATENTS			
2,106,253	1/1938	Neighbors .....	333—78
2,115,882	5/1938	Rust .....	333—78
2,379,664	7/1945	Stanko .....	175—361
2,383,286	8/1945	Beers .....	333—78
2,483,815	10/1949	Easton .....	175—356
2,510,125	6/1950	Meakin .....	333—78
2,579,996	12/1951	Barton .....	333—78
2,634,311	4/1953	Darling .....	173—326

2,745,074	5/1956	Darling .....	339—16
2,854,642	9/1958	Boothe .....	333—78
2,857,576	10/1958	Mechert .....	339—16
2,886,788	5/1959	Cushman et al. ....	333—78
2,889,522	6/1959	Friberg .....	333—78
3,210,715	5/1965	Mitchell et al. ....	339—16

HERMAN KARL SAALBACH, *Primary Examiner.*  
 ELI LIEBERMAN, *Examiner.*  
 C. BARAFF, *Assistant Examiner.*