

Aug. 2, 1966

A. W. FERRARA

3,263,330

SAFETY RAZOR BLADE

Filed Sept. 21, 1964

FIG. 1

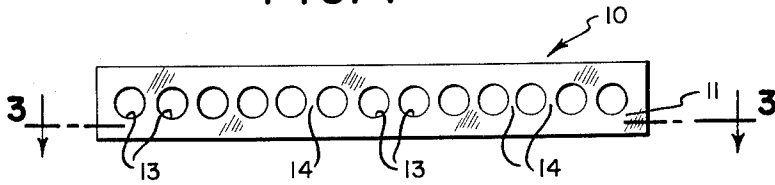

FIG. 2

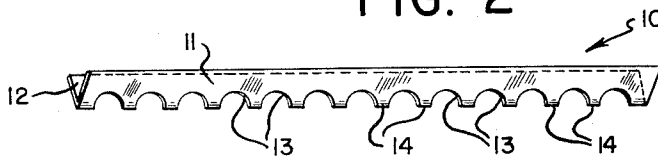

FIG. 3

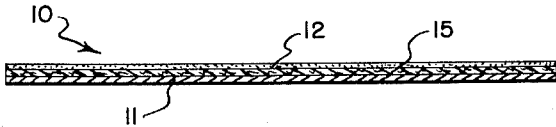

FIG. 4

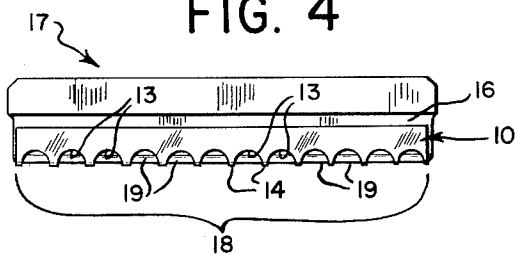

FIG. 5

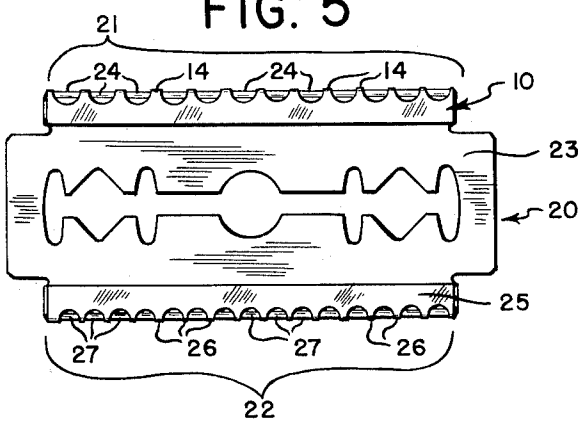
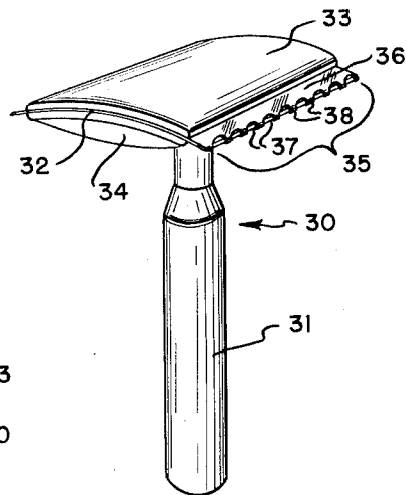

FIG. 6



INVENTOR

Alfred W. Ferrara
BY

ATTORNEY

1

3,263,330

SAFETY RAZOR BLADE

Alfred W. Ferrara, 63 Admiral Lane, Hicksville, N.Y.

Filed Sept. 21, 1964, Ser. No. 397,994

6 Claims. (Cl. 30—346)

This invention pertains generally to blades having a cutting edge and useful for a variety of cutlery purposes; more particularly, it relates to a blade adapted for use in cutting hair, especially human hair, whether on the face, head or other bodily parts.

In the close cutting of hair from parts of the human body, particularly where the hair is to be cut off next to the skin, or shaved, the art of cutlery has progressed from the straight-edge razor primarily in the safety aspect of shaving. Thus, most professional barbers trained in the use of a straight-edge razor prefer to use this instrument in shaving a patron. In the hands of the untrained, however, the straight-edge razor is such a dangerous instrument and has caused so many cuts and scrapes that the so-called safety razor has largely preempted the field of home shaving instruments when a wet shave is desired. In general, the safety razor employs a guard, either in the form of a continuous bar or a series of teeth located adjacent to but out of contact with the razor blade. The bar or teeth are pressed against the skin and provide a support on which the razor rides while the blade cuts hair close to the skin.

The efficiency of the safety razor blade, however, is restricted by the safety factor involved in positioning the blade near the guard. The closer the blade is located with respect to the guard, the less effective the razor will be; when the blade is located too great a distance from the guard, its efficiency is greatly improved, but it then resembles a straight-edge razor in the necessity of handling it with great care.

Another disadvantage of conventional safety razors lies in the fact that most of their bulk, weight and cost is taken up by parts that do not perform a cutting function. Thus, most of the parts of the conventional safety razors are supports, guards and holding means for the razor blade, the blade, itself, being light-weight, compact and relatively inexpensive compared to the remainder of the razor assembly. Although it is the blade, alone, that performs the cutting function, the other parts of the assembly are conventionally made of rust-resistant metal and so increase the cost of the entire assembly as to render it non-disposable after a single use. In certain cases, such as hospital use of a razor preparatory to an operation, it is particularly desirable that the entire assembly be discarded for sanitary reasons after but one use. Guest facilities also could supply single-use razor assemblies to travelers more easily if the assembly was so economical as to be disposable after one use.

It is, therefore, one object of the present invention to provide a razor blade having a cutting efficiency approximating that of a straight-edge razor while providing a safety factor in handling approximating that of a conventional safety razor assembly.

It is another object of the present invention to provide a safety razor assembly that may be so simply and economically constructed as to be adapted for disposal after but a single use.

It is another object of the present invention to provide a safety razor blade.

The present invention is founded on the discovery that an elongated, continuous cutting edge can be rendered less likely to abrade and cut the skin of the user when that cutting edge is divided into a multiplicity of individual cutting edge portions separated from each other and aligned to present a rectilinear, discontinuous cutting

2

surface. In adapting this discovery to a razor blade, the cutting surface formed from the individual cutting edge portions is a terminal surface of a razor blade body. In a preferred form, all of the cutting edge portions are of equal length, which will vary from about $\frac{1}{16}$ to $\frac{1}{2}$ inch, more preferably from about $\frac{1}{8}$ to $\frac{1}{4}$ inch.

According to a preferred embodiment of my invention, the individual cutting edge portions of the blade are separated from each other by teeth in the form of strips of a material resistant to cutting by the cutting edge of the blade. These teeth are fixed to the blade body on either side of the cutting edge and extend across the cutting edge to divide the cutting edge into separate portions. At the cutting edge, the strips or teeth have a width of about $\frac{1}{64}$ to $\frac{1}{16}$ inch, or better still, a width of about $\frac{1}{32}$ to $\frac{1}{16}$ inch.

In accordance with a still more preferred embodiment, the teeth used to divide the cutting edge into individual cutting edge portions are part of a sheet of flexible material that has a row of aligned holes formed in it. The strips are those parts of the sheet that lie between adjacent holes. The sheet is fixed to the blade body in a position in which the holes overlie the cutting edge of the blade and the strips straddle the cutting edge. In order to ensure proper attachment of the sheet to the blade body, one side of the sheet may have a pressure-sensitive coating applied thereto, so that this side will adhere to the blade body when pressed against it.

The present invention may be adapted to a variety of cutting uses, so that the blade with which the strips of the invention are used may be single or double edged. In one form, a double edged blade may be provided with sheets having holes of different sizes and spacings so as to form a cutting edge of relatively small cutting edge portions on one side and an edge of relatively large cutting edge portions on the other side of the blade. In another form, different size cutting edge portions can be formed in the same cutting edge, the longer the individual cutting edge portions, the greater the cutting power of the edge but the less the safety factor when the cut is made.

These and other features, objects and advantages of the present invention will be better understood by reference to the following, specific examples of working embodiments of the invention in the accompanying drawing, which forms a part hereof, and in which:

FIGURE 1 is a plan view of a sheet having a plurality of holes therein in accordance with one embodiment of the invention;

FIGURE 2 is a side elevational view of the sheet of FIGURE 1, with the sheet in partially folded position;

FIGURE 3 is a transverse, sectional view taken along line 3—3 of FIGURE 1;

FIGURE 4 is a side elevational view of a single edged razor blade having a sheet similar to that illustrated in FIGURES 1 to 3 affixed thereto;

FIGURE 5 is an elevational view of a conventional double edged razor blade having affixed to one cutting edge a sheet such as that illustrated in FIGURES 1 to 3 and to its other cutting edge a sheet having smaller holes, and

FIGURE 6 is a perspective view of a razor assembly including a blade according to the present invention.

With reference to the drawings, and specifically with respect to FIGURES 1 and 2, these figures illustrate a guard in the form of a sheet 10 that is substantially flat in unfolded position and has an outer surface 11 and an inner surface 12, part of the latter being visible only in FIGURE 2. Spaced along the length of the sheet 10, but set in from the longitudinal margins of the sheet are a series of holes 13 of equal size. Holes 13 all have

3

the same diameter and in addition are spaced from each other by spacing portion or strips 14 formed in the sheet 10. If desired, the strips or teeth 14 that separate holes 13 can vary in width, the most advantageous variance being a uniform increase or decrease from one end of the sheet to the other.

In order to apply a sheet such as sheet 10 to a razor blade, the sheet is folded, generally along its longitudinal axis as seen in FIGURE 2, so that each hole 13 is bisected by the fold line. Folding takes place in the direction of the inner surface 12, and the sheet 10 may be a laminated structure, as illustrated in FIGURE 3, where outer ply or surface 11 is metal foil, such as aluminum, center ply 15 is paper, and inner surface or ply 12 is a layer of pressure-sensitive adhesive.

When the sheet 10 of FIGURE 3 is folded as shown in FIGURE 2, and then pressed against the sides of a blade body 16 of a razor blade 17 as illustrated in FIGURE 4 of the drawings, the inner surface coating 12 of the sheet will adhere to the blade body 16. In this position the strips 14 will straddle the cutting edge 18 of the blade.

As a blade such as that illustrated in FIGURE 4 is pressed against the skin to shave hair therefrom, it will be apparent that the strips 14 will be located in direct contact with the skin. At this point the cutting edge 18, which has been divided by the strips 14 into a multiplicity of cutting edge portions 19, is not in direct contact with the skin, being separated therefrom by the thickness of the strips 14. Upon further pressure being exerted, cutting edge 18 will contact the skin as the strips or teeth 14 press into the skin. If pressure is now exerted on the razor blade 17 in a shaving direction, the blade will ride on the strips 14 and the cutting edge portions 19 will cut hair close to the skin. If strips 14 are relatively wide, it will usually take greater pressure on them to force the surrounding skin into contact with adjacent edge portions 19 of the blade. So, upon exertion of moderate pressure, the edge portions 19 of cutting edge 18 barely contact the skin and a safe shave is assured. As the widths of the strips decrease, the ease of forcing the skin against the adjacent cutting edge portions increases, so that the same pressure results in a closer shave, but with somewhat less safety. Consequently, the single edged razor blade 17 can be used to give a close or a moderate shave according to the width of the teeth 14. Further, the thickness of the sheet 10 is also a factor of the ease with which edge portions 14 are brought into contact with the skin to be shaved; a thicker sheet will space the edge portions 14 further from the skin and make requisite the application of greater pressure to achieve a shave of the same closeness as a thinner sheet.

Referring now to FIGURE 5, an application of the present invention to a double edged razor blade 20 is illustrated. Blade 20 has two cutting edges 21 and 22 and a blade body 23. As seen, the sheet 10 has been positioned so that teeth 14 straddle cutting edge 21 in the same manner as sheet 10 was positioned with respect to cutting edge 17 of single edged razor blade 17 of FIGURE 4. Strips 14 divide cutting edge 21 into cutting edge portions 24. On the other edge 22 of double edged blade 20 is positioned a different sheet 25, fixed to the blade body 23 so that its teeth 26 straddle edge 22 and divide it into cutting edge portions 27. Since teeth 26 of sheet 25 are all of the same width, cutting action will be the same over the entire length of cutting edge 22 of blade 20. It will be noted that the holes of sheet 25 are smaller than the holes of sheet 10. Assuming that the widths and thicknesses of teeth 14 and 26 are the same, sheet 25 will present more tooth surface per length of cutting edge and thus provide greater safety in a shave. Consequently, edge 21 of blade 20 might be used to shave legs, while edge 22 might be more suited to shaving under arms, where there is greater danger of cutting the skin.

A view of a razor assembly employing a double edged blade according to the present invention is shown in FIG-

4

URE 6. Here a razor, indicated generally at 30, is composed of a handle 31 that serves to hold a blade 32 between upper and lower plates 33 and 34, respectively. Exposed cutting edge 35 of blade 32 is guarded by sheet 36 in a manner similar to that in which edges of blades 17 and 20 are protected, so that separate cutting edge portions 37, spaced by strips or teeth 38, accomplish the cutting function. While a razor assembly such as that identified by numeral 30 may be of more or less conventional construction, it should be noted that, since the razor does not require a guard as do conventional safety razors, the assembly may be made from plastic or other materials that are economical compared with metals and so rendered disposable after a single use.

While only a few variants of embodiments of the present invention have been illustrated and described, it will be apparent that many other variations of my invention may be utilized. Such variations, as in size of holes, spacing of holes from one another, and thickness of the material from which the sheet is formed, will result in different cutting actions that make a particular blade suitable for shaving the face, shaving under arms, shaving hair on the head, cutting hair on the head or other parts of the body, and other uses. Teeth may be formed from a sheet or individually from plastic or other materials. When a double edged blade is employed, and when there are differences in the holes along one cutting edge, two or more different cutting actions can be obtained in the same cutting edge. The razor used to hold the blade may be conventional or different, according to the quality desired in the razor assembly and the manner in which the razor is to be utilized.

With specific respect to variations in the holes in a sheet, the lengths of the cutting edge portions formed by the holes, which might also be referred to as the gap between adjacent teeth, should not be so long as to negative the safety factor, nor so short as to render close cutting difficult. In general, it has been found that lengths varying from about $\frac{1}{16}$ to $\frac{1}{2}$ inch, preferably $\frac{1}{8}$ to $\frac{1}{4}$ inch, are desirable. The width of the teeth at the cutting edge will be about $\frac{1}{4}$ to $\frac{1}{2}$ inch, more preferably $\frac{1}{32}$ to $\frac{1}{16}$ inch. The thickness of the teeth and the sheet in which they are formed will generally be about .001 to .010 inch, more preferably .002 to .004 inch. The sheet may be formed from any material moderately resistant to cutting by the cutting edge of the razor blade. Thus paper, other cellulosic materials, laminated structures, metal, cloth and combinations thereof can all be used, with one or more being preferred for each use.

While the present invention has been illustrated and described with respect to several specific embodiments thereof, it will be recognized that many obvious alterations and modifications may be made in those embodiments and in the invention as generally described without departing from the spirit of the invention. It is desired that all such obvious alterations and modifications be included within the purview of the invention, which is to be limited only by the scope of the following appended claims.

I claim:

1. A safety razor blade, comprising a blade body, a cutting edge formed as a terminal surface in said body, and a sheet of flexible material having a row of aligned holes therein, said holes being separated from each other by spacing portions of said sheet, said sheet being fixed to said blade body in a position in which said holes overlie said cutting edge and said spacing portions of said sheet straddle said cutting edge.

2. A safety razor blade, comprising a blade body, a cutting edge formed as a terminal surface in said body, and a sheet of flexible material composed at least in part of paper and having a row of aligned holes therethrough, said sheet having a coating of pressure-sensitive adhesive on one side thereof, said holes being separated from each other by spacing portions of said sheet, said sheet being

5

fixed to said blades body in a position in which said holes overlie said cutting edge, said spacing portions of said sheet straddle said cutting edge and said adhesive coating is in contact with said blade body.

3. A safety razor blade, comprising a blade body, a cutting edge formed as a terminal surface in said body, and a sheet of flexible material having a row of aligned holes therein, said holes being arranged in groups of holes having the same dimensions, adjacent holes in each group being spaced from each other by equal spacing portions of said sheet, said sheet being fixed to said blade body in a position in which all of said holes overlie said cutting edge and said spacing portions of said sheet all straddle said cutting edge, so that parts of said cutting edge of different sizes are exposed according to the group of holes overlying said cutting edge.

4. A safety razor blade, comprising a blade body, a cutting edge formed as a terminal surface in said body, and a sheet of flexible material having a coating of pressure-sensitive adhesive on one side thereof and a row of aligned holes therethrough, said holes having diameters of $\frac{1}{16}$ to $\frac{1}{2}$ inch and being separated from each other by spacing portions of said sheet that at their narrowest dimension between said holes have a width of $\frac{1}{64}$ to $\frac{1}{16}$ inch, said sheet being .001 to .010 inch in thickness and being fixed to said blade body in a position in which said holes overlie said cutting edge, said spacing portions of said sheet straddle said cutting edge, and said coating is

6

in contact with opposite sides of said blade body.

5. A guard adapted to be fixed to a razor blade, comprising a sheet of flexible material having formed therein a row of holes the centers of which are aligned, said holes being separated from each other by spacing portions of said sheet, said sheet being folded along a straight fold line that intersects the centers of said holes.

6. A guard adapted to be fixed to a razor blade, comprising a sheet of flexible material having formed therein a row of holes the centers of which are aligned, said holes being separated from each other by spacing portions of said sheet, said sheet bearing a coating of pressure-sensitive adhesive on one surface thereof and being folded along a straight line that intersects the centers of said holes, the direction of folding of said sheet being such as to bring the coatings on either side of said fold line toward contact with each other.

References Cited by the Examiner

UNITED STATES PATENTS

1,579,577	4/1926	Thompson	-----	30—355
1,823,808	9/1931	Thompson	-----	30—355
1,846,622	2/1932	Thompson.		

WILLIAM FELDMAN, *Primary Examiner.*

G. WEIDENFELD, *Assistant Examiner.*