

(12) STANDARD PATENT
(19) AUSTRALIAN PATENT OFFICE

(11) Application No. **AU 2017263566 C1**

(54) Title
Insulating device

(51) International Patent Classification(s)
B65D 81/38 (2006.01) **A45C 13/10** (2006.01)
A45C 3/00 (2006.01) **A45C 13/30** (2006.01)
A45C 13/00 (2006.01)

(21) Application No: **2017263566** (22) Date of Filing: **2017.05.12**

(87) WIPO No: **WO17/197230**

(30) Priority Data

(31) Number	(32) Date	(33) Country
15/154,626	2016.05.13	US

(43) Publication Date: **2017.11.16**

(44) Accepted Journal Date: **2019.06.20**

(44) Amended Journal Date: **2019.09.26**

(71) Applicant(s)
YETI Coolers, LLC

(72) Inventor(s)
Seiders, Roy Joseph; Sullivan, Derek G.; Bosway, Andrew M.; Fritzsche, Karl; Keller, Chris

(74) Agent / Attorney
Davies Collison Cave Pty Ltd, Level 15 1 Nicholson Street, MELBOURNE, VIC, 3000, AU

(56) Related Art
US 5931583 A
US 4826060 A
US 20140254956 A1

(12) INTERNATIONAL APPLICATION PUBLISHED UNDER THE PATENT COOPERATION TREATY (PCT)

(19) World Intellectual Property
Organization

International Bureau

(43) International Publication Date
16 November 2017 (16.11.2017)



(10) International Publication Number
WO 2017/197230 A1

(51) International Patent Classification:

B65D 81/38 (2006.01) *A45C 13/10* (2006.01)
A45C 3/00 (2006.01) *A45C 13/30* (2006.01)
A45C 13/00 (2006.01)

MC, MK, MT, NL, NO, PL, PT, RO, RS, SE, SI, SK, SM,
TR), OAPI (BF, BJ, CF, CG, CI, CM, GA, GN, GQ, GW,
KM, ML, MR, NE, SN, TD, TG).

(21) International Application Number:

PCT/US2017/032351

Published:

— with international search report (Art. 21(3))

(22) International Filing Date:

12 May 2017 (12.05.2017)

(25) Filing Language:

English

(26) Publication Language:

English

(30) Priority Data:

15/154,626 13 May 2016 (13.05.2016) US

(71) Applicant: **YETI COOLERS, LLC** [US/US]; 5301
Southwest Parkway, Suite 200, Austin, TX 78735 (US).

(72) Inventors: **SEIDERS, Roy, Joseph**; c/o YETI Coolers,
LLC, 5301 Southwest Parkway; Suite 200, Austin, TX
78735 (US). **SULLIVAN, Derek, G.**; c/o YETI Coolers,
LLC, 5301 Southwest Parkway; Suite 200, Austin, TX
78735 (US). **BOSWAY, Andrew, M.**; c/o YETI Cool-
ers, LLC, 5301 Southwest Parkway; Suite 200, Austin, TX
78735 (US). **FRITZSCHE, Karl**; c/o YETI Coolers, LLC,
5301 Southwest Parkway; Suite 200, Austin, TX 78735
(US). **KELLER, Chris**; c/o YETI Coolers, LLC, 5301
Southwest Parkway; Suite 200, Austin, TX 78735 (US).

(74) Agent: **VAN PELT, Bradley, J.**; Ten South Wacker Drive,
Suite 3000, Chicago, IL 60606 (US).

(81) Designated States (unless otherwise indicated, for every
kind of national protection available): AE, AG, AL, AM,
AO, AT, AU, AZ, BA, BB, BG, BH, BN, BR, BW, BY, BZ,
CA, CH, CL, CN, CO, CR, CU, CZ, DE, DJ, DK, DM, DO,
DZ, EC, EE, EG, ES, FI, GB, GD, GE, GH, GM, GT, HN,
HR, HU, ID, IL, IN, IR, IS, JP, KE, KG, KH, KN, KP, KR,
KW, KZ, LA, LC, LK, LR, LS, LU, LY, MA, MD, ME, MG,
MK, MN, MW, MX, MY, MZ, NA, NG, NI, NO, NZ, OM,
PA, PE, PG, PH, PL, PT, QA, RO, RS, RU, RW, SA, SC,
SD, SE, SG, SK, SL, SM, ST, SV, SY, TH, TJ, TM, TN, TR,
TT, TZ, UA, UG, US, UZ, VC, VN, ZA, ZM, ZW.

(84) Designated States (unless otherwise indicated, for every
kind of regional protection available): ARIPO (BW, GH,
GM, KE, LR, LS, MW, MZ, NA, RW, SD, SL, ST, SZ, TZ,
UG, ZM, ZW), Eurasian (AM, AZ, BY, KG, KZ, RU, TJ,
TM), European (AL, AT, BE, BG, CH, CY, CZ, DE, DK,
EE, ES, FI, FR, GB, GR, HR, HU, IE, IS, IT, LT, LU, LV,

(54) Title: INSULATING DEVICE

(57) Abstract: An insulating device can include an aperture having a waterproof closure which allows access to the chamber within the insulating device. The closure can help prevent any fluid leakage into and out of the insulating device if the insulating device is overturned or in any configuration other than upright. The closure may also prevent any fluid from permeating into the chamber if the insulating device is exposed to precipitation, other fluid, or submersed under water. This construction results in an insulating chamber that is substantially impervious to water and other liquids when the closure is sealed.



WO 2017/197230 A1

INSULATING DEVICE

Cross-Reference Section

[01] This application claims priority to U.S. Application No. 15/154,626, filed on May 13, 2016. U.S. Application No. 15/154,626 is a continuation-in-part of U.S. Application No. 14/831,641, filed on August 20, 2015, which is a divisional application of U.S. Application No. 14/479,607 filed on September 8, 2014, now U.S. Patent No. 9,139,352, which claims priority to U.S. Application No. 61/937,310 filed on February 7, 2014. All of the above applications are incorporated fully herein by reference.

Field

[02] The present disclosure relates generally to non-rigid, portable, insulated devices or containers useful for keeping food and beverages cool or warm, and, more particularly, an insulating device with a waterproof closure.

Background

[03] Coolers are designed to keep food and beverages at lower temperatures. Containers may be composed of rigid materials such as metal or plastics or flexible materials such as fabric or foams. Coolers can be designed to promote portability. For example, rigid containers can be designed to incorporate wheels that facilitate ease of transport or coolers can be designed in smaller shapes to allow individuals to carry the entire device. Non-rigid containers can be provided with straps and/or handles and may in certain instances be made of lighter weight materials to facilitate mobility. Non-rigid coolers that maximize portability can be designed with an aperture on the top that allows access to the interior contents of the cooler. The aperture can also be provided with a closure.

Summary

[04] In accordance with the present invention there is provided an insulating device having a front, a rear, and a base, wherein the insulating device is configured to stand upright from the base, comprising:
an outer shell defining a sidewall and the base, the outer shell having a front portion and a

rear portion;

an inner liner forming a storage compartment, the inner liner having a front portion and a rear portion;

an insulating layer positioned in between the outer shell and the inner liner, the insulating layer providing insulation for the storage compartment;

wherein top portions of the front and rear portions of the outer shell and the front and rear portions of the inner liner are connected by a joint;

a vertically extending front facing surface on the front of the insulating device;

an opening configured to allow access to the storage compartment; and

a closure located on the front facing surface adapted to substantially seal the opening, the closure being substantially waterproof so as to resist liquid from exiting the opening when the insulating device is in any orientation;

wherein the insulating layer has a first height extending from the base and a second height extending from the base, wherein the first height is greater than the second height, and the insulating layer in the front of the insulating device extends to the second height and the insulating layer in the rear of the insulating device extends to the first height.

[04a] In accordance with the present invention there is also provided a method of forming an insulating device having a front, a rear, a base having a bottom perimeter, and a vertically extending front facing surface comprising:

forming an inner liner the inner liner defining a storage compartment; forming an outer shell defining a sidewall, the outer shell having a front portion and a rear portion;

placing an insulating layer comprising a first portion and a base portion, wherein the base portion is located in the base of the insulating device, in between the outer shell and the inner liner, the insulating layer providing insulation for the storage compartment, wherein the first portion of the insulating layer has a first height and a second height, wherein the first height is greater than the second height, and the first portion of the insulating layer in the front of the insulating device extends to the second height and the insulating layer in the rear of the insulating device extends to the first height

connecting top portions of the front and rear portions of the outer shell and the front and rear portions of the inner liner with a joint;

placing an opening on the front facing surface in the inner liner and the outer shell; and

placing a closure between the inner liner and the outer shell, the closure adapted to substantially seal the opening, the closure being substantially waterproof so as to resist liquid from exiting the opening when the insulating device is in any orientation.

[05] Aspects of the disclosure herein may relate to insulating devices having one or more of (1) a waterproof closure (2) an outer shell, (3) an inner liner, (4) an insulating layer floating freely in between the outer shell and the inner liner, or (5) a waterproof storage compartment.

Brief Description of the Drawings

[06] The foregoing Summary, as well as the following Detailed Description, will be better understood when considered in conjunction with the accompanying drawings in which like reference numerals refer to the same or similar elements in all of the various views in which that reference number appears.

[07] Fig. 1A shows a left front perspective view of an example insulating device in accordance with an aspect of the disclosure;

[08] Fig. 1B shows a frontside perspective view of the example insulating device of Fig. 1A without the shoulder strap;

[09] Fig. 2 shows a backside perspective view of the example insulating device of Fig. 1A without the shoulder strap;

[10] Fig. 3A shows a top perspective view of the example insulating device of Fig. 1A without the shoulder strap;

[11] Fig. 3B shows a top view of a portion of the example insulating device of Fig. 1A;

[12] Fig. 3C shows a portion of an alternate top perspective view of the example insulating device of Fig. 1A;

[13] Fig. 4 shows a bottom perspective view of the example insulating device of Fig. 1A;

- [14] Fig. 5A illustrates a schematic of a cross-sectional view of the example insulating device of Fig. 1A;
- [15] Fig. 5B illustrates another schematic of an enlarged portion of a cross-sectional view of the example insulating device of Fig. 1A;
- [16] Fig. 6 illustrates an exemplary process flow diagram for forming an insulating device;
- [17] Figs. 7A-7J illustrate exemplary methods of forming an insulating device;
- [18] Figs. 8A and 8B depict perspective views of an alternative example insulating device;
- [19] Fig. 9 depicts a portion of an exemplary closure and an example test method for determining if an insulating device maintains the contents therein;
- [20] Fig. 10 depicts an example test for determining the strength of an insulating device;
- [21] Fig. 11 shows a front view of another exemplary insulating device;
- [22] Fig. 12 shows a side view of the exemplary insulating device of Fig. 11;
- [23] Fig. 13 shows a front perspective view of the exemplary insulating device in an alternate configuration;
- [24] Fig. 14A shows a side and cross-sectional view of the exemplary insulating device of Fig. 11;
- [25] Fig. 14B shows an enlarged section of Fig. 14A;
- [26] Fig. 15 shows a schematic exploded view of an exemplary insulation layer for the example insulating device of Fig. 11;

- [27] Fig. 16A shows a portion of another example insulating device;
- [28] Fig. 16B shows a side view of the example insulating device of Fig. 16A;
- [29] Fig. 17 shows a perspective view of another example insulating device;
- [30] Fig. 18 shows a front view of the insulating device of Fig. 17;
- [31] Fig. 19 shows a rear view of the insulating device of Fig. 17;
- [32] Fig. 20 shows a side view of the insulating device of Fig. 17;
- [33] Fig. 21 shows a cross-sectional view of the insulating device of Fig. 17;
- [34] Fig. 22 shows a schematic exploded view of an exemplary insulation layer for the example insulating device of Fig. 17;
- [35] Fig. 22A shows a front view of an exemplary insulation layer for the example insulating device of Fig. 17;
- [36] Fig. 23 illustrates an exemplary testing method.

Detailed Description

[37] In the following description of the various examples and components of this disclosure, reference is made to the accompanying drawings, which form a part hereof, and in which are shown by way of illustration various example structures and environments in which aspects of the disclosure may be practiced. It is to be understood that other structures and environments may be utilized and that structural and functional modifications may be made from the specifically described structures and methods without departing from the scope of the present disclosure.

[38] Also, while the terms “frontside,” “backside,” “top,” “base,” “bottom,” “side,” “forward,” and “rearward” and the like may be used in this specification to describe various example features and elements, these terms are used herein as a matter of convenience, *e.g.*, based on the example orientations shown in the figures and/or the orientations in typical use. Nothing in this specification should be construed as requiring a specific three dimensional or spatial orientation of structures in order to fall within the scope of the claims.

[39] FIGS. 1-4 depict an exemplary insulating device 10 that can be configured to keep desired contents stored cool or warm for an extended period of time. The insulating device can generally include an outer shell 501, a closure 301, an insulating layer 502, and an inner liner 500. As shown in Fig. 3C, the inner liner 500 forms a chamber or receptacle 504 for receiving the desired contents therein. As shown in Fig. 1A, various handles, straps, and webs (*e.g.* 210, 212, 218, 224) can also be included on the insulating device 10 for carrying, holding, or securing the insulating device 10.

[40] The insulating device 10 can be configured to keep desired contents stored in the receptacle 504 cool or warm for an extended period of time. In one example, the insulating device 10 can also be designed to maintain water inside the inner chamber or receptacle 504, and the insulating device 10 can be configured to be water “resistant” from the outside in. In other words, the insulating device 10 can be formed “water tight” inside the inner liner 500, and water cannot leak into the inner liner 500 from the outside or out from the inside of the inner liner 500 when the closure 301 is in the closed position.

[41] Fig. 4 depicts a bottom view of the insulating device 10. As shown in Fig. 4, the insulating device 10 may include a base 215 and a base support ridge 400. The base support ridge 400 can provide structural integrity and support to the insulating device 10 when the insulating device 10 is placed onto a surface.

[42] In one example, as shown in Figs. 3A and 4, the top of the outer shell 501 has a first perimeter circumference (T_{cir}) and the bottom of the outer shell 501 has a second perimeter circumference or a base perimeter 401 (B_{cir}). The circumference of the top of the outer shell 501 can be equal to the circumference on the bottom when folded into a cylinder, and B_{cir} can be equal to T_{cir} . In one example, the first circumference and the second circumference can both have an oval shape to form an elongated or elliptical cylinder. In one example, the top outer layer 501a can have a length of 23.5 inches and a width of 5.5 inches. Therefore, the length to width ratio of

the top outer layer 501a can be approximately 4.3. Additionally, the base 215 can have a length of 20.0 inches and a width of 12.25 inches. Therefore, the length to width ratio of the base 215 is approximately 1.6. In this example, the length to width ratio of the upper wall can be greater than the length to width ratio of the base.

[43] In one example, as shown in Fig. 5A, the inner layer or inner liner 500 can be formed of a top inner liner portion or first inner liner portion 500a, an inner layer mid portion or second portion 500b, and an inner layer bottom portion 500c. The top inner liner portion 500a, the inner layer mid portion 500b, and the inner layer bottom portion 500c are secured together, by for example welding, to form the chamber 504. The chamber 504 can be a “dry bag,” or vessel for storing contents. In one example, after the top inner liner portion 500a, the inner layer mid portion 500b, and the inner layer bottom portion 500c are secured or joined together, a tape, such as a TPU tape can be placed over the seams joining the sections of the chamber 504. The inner liner 500 can, thus, either maintain liquid in the chamber 504 of the insulating device 10 or prevent liquid contents from entering into the chamber 504 of the insulating device 10. In one example, as will be described in further detail below, the inner liner 500 can be suspended in the insulating device 10 by only the closure 301.

[44] The insulating layer 502 can be located between the inner liner 500 and the outer shell 501, and can be formed as an insulator to assist in maintaining the internal temperature of the receptacle 504. In one example, the insulating layer 502 can be a free floating layer that is not attached directly to the outer shell 501 or the inner liner 500. The insulating layer 502 can be formed of a first portion 502a and a second portion or base portion 502b. The first portion 502a and the second portion 502b can be formed of an insulating foam material as will be described in further detail below.

[45] The first portion 502a can have a rectangular shape that maintains its form when folded into a cylinder and placed in between the inner liner 500 and the outer shell 501 and when encased from above by the outer shell 501. The insulating layer 502 maintains its shape which results in the basic oval-cylindrical shape of the insulating device 10. Therefore, similar to the outer shell 501, the top of the insulating layer 502 has a first perimeter circumference, and the bottom of the insulating layer 502 has a second perimeter circumference. The first perimeter circumference of the insulating layer 502 can be equal to the second perimeter circumference of the insulating layer 502.

[46] The base portion 502b can be included to provide additional insulation along the insulating device 10 at base 215. The base portion 502b can be formed as an oval shape to close off a lower opening 506 formed by the cylindrical shape of the insulating layer 502.

[47] Additionally, the bottom portion of the insulating device 10 can include an additional base support layer 505, which adds to the insulation and the structural integrity of the insulating device 10. The base support layer 505 may also provide additional protection around the bottom of the insulating device 10. In one example, the base support layer 505 can be formed from EVA foam. The base support layer 505 may include a certain design such as a logo or name that can be molded or embossed directly into the material. The base support ridge 400, which provides structural integrity and support to the insulating device 10 can also be molded or embossed directly into the base support layer 505. In one example, the base support layer 505 and the base portion 502b can be detached for ease of assembly.

[48] The outer shell 501 can be formed of a top outer layer portion or first shell portion 501a, an outer layer or second outer shell portion 501b, and a bottom or third shell portion 501c. The outer shell 501 provides a covering for the insulating device 10. In one example, the insulating layer 502 can be suspended freely within the outer shell 501. However, it is contemplated that any of the layers could be secured or formed as a one- piece integral structure. The outer shell 501 can be configured to support one or more optional handles or straps (e.g. 210, 212, 218). In this regard, the outer shell 501 can also include multiple reinforcement areas or patches 220 that are configured to assist in structurally supporting the optional handles or straps (e.g. 210, 212, 218). The handles or straps (e.g. 210, 212, 218) and other attachments can be stitched using threads 222, however these threads 222 do not, in one example, extend through the outer shell 501 into the insulating layer 502. Rather, the threads are sewn to the patches 220, and the patches 220 can be RF welded to the outer shell 501 or by any other method disclosed herein.

[49] As shown in Fig. 5A, the first outer shell portion 501a may be attached to the second shell portion 501b by stitching 510. However, the first outer shell portion 501a can be attached to the second shell portion 501b using any known method, e.g., polymer welding, stitching, or other adhesive around the entire perimeter of the second shell portion 501b.

[50] Additionally, in one example, the base support layer 505, which can be formed from EVA foam, can be secured to bottom or third shell portion 501c by lamination. The second shell portion 501b can be secured to the third shell portion 501c and the base support layer 505

by polymer welding (e.g. RF welding), stitching, or adhesives.

[51] The insulating device 10 can include two carry handles 210 that are connected to the frontside 216 of the insulating device 10 and the backside 217 of the insulating device 10. In one particular example, a shoulder strap 218 can be attached via plastic or metal clip to the ring 214 attached to side handles 212 to facilitate carrying insulating device 10 over the shoulder. The insulating device 10 may also include side handles 212 on each end of the cooler. The side handles 212 provide the user with another option for grasping and carrying the insulating device.

[52] Carry handles 210 may also form a slot for receiving rings 214 near the bottom of the attachment point of the carry handles to the insulating device 10. The rings 214 can be secured to the carry handles 210 and the attachment points 213 by stitching, adhesive, or polymer welding and can be used to help secure or tie down the insulating device 10 to another structure such as a vehicle, vessel, camping equipment, and the like or various objects such as keys, water bottle bottles, additional straps, bottle openers, tools, other personal items, and the like.

[53] Additionally, as shown in Fig. 2, webbing formed as loops 224 can be sewn onto the straps forming the handles 210 on the back of the insulating device 10. The loops 224 can be used to attach items (e.g., carabineers, dry bags) to the insulating device 10. The side handles 212 can also provide the user with another option for securing the insulating device 10 to a structure.

[54] In one example, the carry handles 210, side handles 212, shoulder strap 218 and attachment points 213 can be constructed of nylon webbing. Other materials may include polypropylene, neoprene, polyester, Dyneema, Kevlar, cotton fabric, leather, plastics, rubber, or rope. The carry handles 210 and side handles 212 can be attached to the outer shell by stitching, adhesive, or polymer welding.

[55] The shoulder strap 218 can be attached to the insulating device 10 at attachment points 213. The attachment points 213 can be straps that also form a slot for receiving rings. The rings 214 can provide for the attachment of the shoulder strap 218.

[56] In one example, the rings 214 can be Acetal D-rings. Rings 214 in can be plastic, metal, ceramic, glass, alloy, polypropylene, neoprene, polyester, Dyneema, and Kevlar, cotton fabric, leather, plastics, rubber, or rope. Rings 214 can include other shapes, sizes, and configurations other than a "D" shape. Examples include round, square, rectangular, triangular, or rings with multiple attachment points. Additionally, pockets or other storage spaces can be attached to the outside of the insulating device 10 in addition to the carry handles 210 and side handles 212.

[57] In one example, the closure 301 can be substantially waterproof or a barrier to prevent liquid contents from either entering or exiting the insulating device. Additionally, the closure 301 can be impervious to liquid such that insulating device 10 liquid penetration is prevented at any orientation of the insulating device 10. Also maintaining the closure 301 in flat plane can assist in providing a water tight seal.

[58] Figs. 3A-3C depicts top views of the insulating device 10, and depicts the top outer layer or the first outer shell portion 501a and the closure 301. The top outer layer 501a depicted in Fig. 3A can be secured to the closure 301. In one example, the closure 301 can be a waterproof zipper assembly and can be watertight up to 7 psi above atmospheric pressure during testing with compressed air. However, in other examples, the water tightness of the closure 301 can be from 5 psi to 9 psi above atmospheric pressure and in other examples, the water tightness of the closure 301 can be from 2 psi to 14 psi above atmospheric pressure. The waterproof zipper assembly can include a slider body 303 and pull-tab 302. Fig. 3B shows a magnified view of the closure 301 that includes bottom stop 304 and teeth or a chain 305. In one particular example, the waterproof zipper assembly can be constructed with plastic or other non-metallic teeth 305 to prevent injury when retrieving food or beverages from the inner chamber 504.

[59] As shown in Fig. 3C, the closure 301 is open or unzipped and an aperture 512 formed in the outer shell 501 and the inner liner 500 is open and reveals the inner liner 500 and the inner chamber 504. It is contemplated that the closure or seal 301 can include various sealing devices in addition to the depicted waterproof zipper assembly in Figs. 3A-3C. For example, Velcro, snaps, buckles, zippers, excess material that is folded multiple times to form a seal such as a roll-down seal, seals, metal or plastic clamps and combinations thereof could be used to seal the inner liner 500 and the outer shell 501.

[60] Figs. 8A and 8B depict another exemplary insulating device 1010, which has similar features and functions as the example discussed above in relation to Figs. 1A-5B in which like reference numerals refer to the same or similar elements. However, in this example, a loop patch 1015 can be provided on the front of the bag. The loop patch 1015 can be configured to receive many types of items or a corresponding group of hooks, which can be placed onto the surface anywhere on various items, such as fishing lures, keys, bottle openers, card holders, tools, other personal items, and the like. The loop patch 1015 can include a logo, company name, personalization, or other customization. The loop patch 1015 can be formed of by needle loops

and can have a high cycle life of over 10,000 closures. In addition, the loop patch can be washable and UV resistant to prevent discoloration. The loop patch can be selected based on a desired sheer and peel strength depending on the types of materials that are to be secured to the insulating device 1010.

[61] In the example shown in Figs. 8A and 8B, additionally, a strip 1013 of material can be provided along the bottom of the bag, which can provide additional strength and reinforcement to the outer shell 1501, and may enhance the aesthesis of the insulating device 1010.

[62] Example methods of forming the insulating device 10 will now be described. A general overview of an exemplary assembly process of the insulating device 10 is depicted schematically in FIG. 6. The various steps, however, need not necessarily be performed in the order described. As shown in step 602 first the portions used to form the inner liner 500, the outer shell 501, and the insulating layer 502 can be formed or cut to size. In step 604, a top cap assembly 300 can be assembled to the closure 301. In step 606, the inner liner 500 can be formed, and in step 608, the top cap assembly 300 can be welded to the inner liner 500. In step 610, the outer shell 501 can be formed. In step 612, the insulation layer 502 can be assembled, and in step 616, the insulation layer 502 can be placed into the inner liner. Finally, in step 618, the top cap assembly 300 can be secured to the outer shell 501.

[63] Referring to step 602, as shown in Fig. 7A and 7B, inner liner top portions or first inner liner portions 500a and top outer layer 501a that form the top cap assembly 300 can be formed or cut to size. Fig. 7C shows a second portion or base portion 502b of the insulating layer 502 being cut or formed to size from stock foam. In this example, the base portion 502b is cut from the stock foam 530, by cutting tool 700. In one example, the cutting tool 700 can be formed in the shape of the base portion 502b.

[64] Referring now to step 604 and Fig. 7D, the top outer layer 501a and the top inner liner portion 500a can be secured to the closure 301 to form the top cap assembly 300, and the top outer layer 501a and the top inner liner portion 500a can be secured to the closure 301 in a flat, horizontal plane. Referring to Figs. 5A-5B the top outer layer 501a can be attached by polymer welding or adhesive to closure 301. In particular as shown schematically in Fig. 5B, the closure 301 can be provided with a first flange 301a and a second flange 301b, which can form waterproof zipper tape 306. The top outer layer 501a can be attached directly to the top surfaces of the first flange 301a and the second flange 301b of the closure 301. In one example, the first flange 301a and

the second flange 301b, can be RF welded to the underside of the top outer layer 501a. In another example, as shown in Fig. 7E, the top inner liner portion 500a can be provided with tabs 515. Tabs 515 can assist in the assembly process to keep the outer strips of the top inner liner portion 500a in place during assembly and can be removed after the top cap assembly 300 is formed.

[65] In one example, the top inner liner portion 500a can be attached to the structure of the insulating device 10 as shown schematically in Fig. 5B. In particular, the top inner liner portion 500a can be attached to the bottom of the closure 301. For example, as shown in Fig. 5B, and a first end 540a and a second end 540b of the top inner liner portion 500a can be attached to undersides of the first flange 301a and the second flange 301b. The top inner liner portion 500a and the top outer layer 501a can be attached to the closure

301 by polymer welding or adhesive. Polymer welding includes both external and internal methods. External or thermal methods can include hot gas welding, hot wedge welding, hot plate welding, infrared welding and laser welding. Internal methods may include mechanical and electromagnetical welds. Mechanical methods may include spine welding, stir welding, vibration welding, and ultrasonic welding. Electromagnetical methods may include resistance, implant, electrofusion welding, induction welding, dielectric welding, RF (Radio Frequency) welding, and microwave welding. The welding can be conducted in a flat or horizontal plane to maximize the effectiveness of the polymer welding to the construction materials. As a result, a rugged watertight seam can be created that prevents water or fluids from escaping from or into the inner chamber 504.

[66] In a particular example, the polymer welding technique to connect the top inner liner portion 500a to the bottom of the closure 301 can include RF welding. The RF welding technique provides a waterproof seam that prevents water or any other fluid from penetrating the seam at pressure up to 7 psi above atmospheric pressure. The insulating device 10, therefore, can be inverted or submerged in water and leakage is prevented both into and out of the internal chamber 504 formed by inner liner 500. In one example, the insulating device 10 can be submerged under water to a depth of about 16 feet before water leakage occurs. However, it is contemplated that this depth could range from about 11 feet to 21 feet or 5 feet to 32 feet before any leakage occurs.

[67] Next referring to step 606 and Fig. 7F, the inner layer mid-portion 500b can be formed by RF welding. As shown in Fig. 7F, the inner layer mid-portion 500b can be formed of a rectangular sheet of material. The inner layer mid-portion 500b can also be secured to the inner layer bottom portion 500c in a subsequent step not shown.

[68] Referring to step 608 and Figs. 7G and 7H, the inner layer mid portion 500b and the inner layer bottom portion 500c can be secured to the top cap assembly 300 using an RF welding operation.

[69] Referring to step 610, the second shell portion 501b and the third shell portion 501c, which supports the base support layer 505, can be RF welded to construct the outer shell 501 for the insulating device 10. In one example, as shown schematically in Fig. 5A, the top outer layer 501a can be sewed to the perimeter of the second shell portion 501b to form the outer shell 501 of the insulating device. A fabric binding can be used to cover the stitched seam edges of the second shell portion 501b and the top outer layer 501a. This assists in closing or joining the outer shell 501 around the insulating layer 502.

[70] Referring to step 612 and Fig. 7I, the insulating layer 502 can be constructed. In one example the first portion 502a of the insulating layer 502 can be formed into a rectangular shape and can be secured at the smaller sides of the rectangular shape using double sided tape to form the cylindrical shape. The second portion or base portion 502b can be formed into an oval shape that can have a smaller circumference than the circumference of the cylindrical shape of the first portion 502a. The second portion 502b can be secured to the first portion 502a also using a double-sided tape to form the insulating layer 502. In one example, double sided tape can be placed either around the inner perimeter of the first portion 502a cylinder or around the outer perimeter of the base portion 502b, and the base portion 502b can be adhered to the first portion 502a. Other methods of securing the base portion 502b to the first portion 502a to form the insulating layer 502 are contemplated, such adhesives or polymer welding.

[71] Referring to step 614, the assembled insulating layer 502 can be placed into the outer shell 501. In step 616, the formed inner liner 500 and top cap assembly 300 can be placed into the insulating layer 502.

[72] Finally in step 618 the top cap assembly 300 can be sewed to the outer shell 501 to form seams 520 as depicted schematically in Fig. 5A. In this way, neither the inner liner 500 nor the outer shell 501 need to be bound to the insulating layer 502. Also the inner liner 500 is only connected to the closure 301 and the closure 301 holds the inner liner and the outer shell 501 together, which results in a simpler manufacturing process. After sewing the top cap assembly 300 to the outer shell 501, a fabric binding is added to cover the raw edges adjacent the seams 520. Thus, the top seams 520 can be the only primary seams on the insulating device 10 that are created by

stitching.

[73] In one particular example, the inner liner 500 and the outer shell 501 can be constructed from double laminated TPU nylon fabric. Nylon fabric can be used as a base material for the inner liner 500 and the outer shell 501 and can be coated with a TPU laminate on each side of the fabric. The TPU nylon fabric used in one particular example is 0.6 millimeters thick, is waterproof, and has an antimicrobial additive that meets all Food and Drug Administration requirements. In one specific example, the nylon can be 840d nylon with TPU. Alternative materials used to manufacture the inner shell or chamber 504 and outer shell 501 include PVC, TPU coated nylon, coated fabrics, and other weldable and waterproof fabrics.

[74] A closed cell foam can be used to form the insulating layer 502 that is situated in between the inner liner 500 and the outer shell 501. In one example, the insulating layer 502 is 1.0 inches thick. In one example, the insulating layer 502 can be formed of NBR/PVC blend or any other suitable blend. The thermal conductivity of the insulating layer 502 can be in the range of 0.9 to 5 lbs/ft^3 . In one example, the thermal conductivity of the insulating layer 502 can be in the range of 0.25 $\text{BTU.in}/(\text{hr}\cdot\text{sqft}\cdot^\circ\text{F})$, and the density of the insulating layer 502 can be 3.5 lbs/ft^3 .

[75] The foam base can be manufactured from an NBR/PVC blend or any other suitable blend. In addition to the base portion 502b of the insulating layer 502, the insulating device 10 may also include an outer base support layer 505 constructed of foam, plastic, metal or other material. In one example, the base portion 502b can be detached from the base support layer. In one example, the base portion 502b is 1.5 inches thick. Additionally as shown in Fig. 5A, the EVA foam base support layer 505 can be 0.2 inches thick. Although the base support layer 505 is laminated to the base outer layer or third shell portion 501c, in an alternative example, the base support layer 505 can be attached to the bottom of the base portion 502b by co-molding, polymer welding, adhesive, or any known methods.

[76] A heat gain test was conducted on the exemplary insulating device 10. The purpose of a heat gain test is to determine how long the insulating device can keep temperature below 50°F at an ambient of $106^\circ\text{F} \pm 4$ with the amount of ice based on its internal capacity.

[77] The procedure is as follows:

[78] 1. Turn on the oven and set to $106^\circ\text{F} \pm 4$. Allow the oven to stabilize for at least one hour.

[79] 2. Turn on the chart recorder. The recorder shall have three J-thermocouples connected to it to chart the following temperatures: (1) Test unit, (2) Oven, and (3) Room ambient.

[80] 3. Stabilize the test unit by filling it to half its capacity with ice water, and allowing it to sit for 5 minutes at room temperature ($72\text{ }^{\circ}\text{F} \pm 2$).

[81] 4. After 5 minutes, pour out the contents, and immediately connect the J-thermocouple end to the inside bottom center of the unit. The thermocouple wire end must be flush to the inside bottom surface and secured with an adhesive masking tape.

[82] 5. Pour the correct amount of ice ensuring the thermocouple wire is not moved. Amount of ice is based on 4 lbs. per cubic feet of the internal capacity of the unit.

[83] 6. Close the lid and position the test unit inside the oven.

[84] 7. Close the oven making sure the thermocouple wires are functioning.

[85] 8. Mark the start of the chart recorder.

[86] Apparatus: 1. Oven. 2. Ice. 3. Chart Recorder. 4. J-Thermocouples (3). Results: 1. Cold Retention Time: Elapsed time from $<32^{\circ}\text{F}$ to 50°F in decimal hours. 2. Heat Gain Rate ($^{\circ}\text{F}/\text{Hr}$): $(50^{\circ}\text{F} - 32^{\circ}\text{F}) \div \text{Elapsed Time} = 18^{\circ}\text{F} \div \text{Elapsed Time}$

[87] In one test of the example insulating device, the heat gain rate equaled 1.4 degF/hr assuming 26.5 quarts capacity and used 3.542lbs of ice for the test.

[88] The ability of the insulating device 10 to withstand interior leaks can also be tested to see how well the insulating device maintains the contents stored in the storage compartment or receptacle 504. In one example test, the insulating device 10 can be filled with a liquid, such as water, and then can be inverted for a predetermined time period to test for any moisture leaks. In this example, the insulating device 10 is filled with a liquid until approximately half of a volume of the receptacle 504 is filled, e.g. 3 gallons of water, and the closure 301 is then closed fully to ensure that the slider body 303 is completely sealed into the horseshoe-shaped portion 308. The entire insulating device 10 is then inverted and held inverted for a time period of 30 minutes. The insulating device 10 is then reviewed for any leaks.

[89] The insulating device 10 can be configured to withstand being held inverted for 30 minutes without any water escaping or leaving the receptacle 504. In alternative examples, the insulating device can be configured to withstand being held inverted for 15 minutes to 120 minutes without any water escaping or leaving the receptacle 504. To perform this test, it may be helpful to lubricate the closure to ensure that the closure is adequately sealed. For example, as shown in

Fig. 9, a horseshoe-shaped portion 308 of the closure 301 is provided with lubricant 309.

[90] The strength and durability of the fabric forming the outer shell 501, inner liner 500 and the insulating layer 502 of the insulating device 10 may also be tested. In one example, the test can be devised as a puncture test. In particular, this test can be designed as an ASTM D751-06 Sec. 22-25 screwdriver puncture test. In one example, the insulating device 10 can withstand 35 lbs to 100 lbs of puncture force.

[91] The handle strength and durability of the insulating device 10 can also be tested. One such example test is depicted in Fig. 10. As depicted in Fig. 10, the closure 310 can be fully closed, one of the carry handles 210 can be hooked to an overhead crane 600, and the opposite carry handle 210 is hooked to a platform 650, which can hold weight. In one example, the platform 650 can be configured to hold 200 lbs. of weight. During the test, the crane 600 is slowly raised, which suspends the insulating device 10 in a position where the bottom plane of the insulating device 10 is perpendicular with the floor. In one example, the insulating device 10 can be configured to hold 200 lbs. of weight for a minimum of 3 minutes without showing any signs of failure. In alternative examples, the insulating device can be configured to hold 100 lbs. to 300 lbs. of weight for 1 to 10 minutes without showing signs of failure.

[92] Figs. 11-15 show another example insulating device 2010. The example insulating device 2010 can be of a similar construction to the above examples, where like reference numerals represent like features having similar functionality. However, the example insulating device 2010 can also include a fold-down flap or portion 2307 to assist in insulating the closure 2311 of the insulating device 2010. Specifically, the closure 2311, which can be a zipper in accordance with the other examples discussed herein, can be included on a fold-down flap or portion 2307 and can be front facing in that it is located on a front surface or wall of the insulating device 2010. The front facing closure 2311, can allow for additional user access to the insulating device 2010, and the fold-down flap or portion 2307 can help to provide additional insulation at the closure 2311. In this example, when the fold-down flap 2307 is in the extended position and the closure 2311 is open or unsealed, the contents in the insulating device 2010 maintain the closure 2311 in the open position for better access of the contents of the insulating device 2010. This may assist the user to be able to more easily access the contents of the insulating device 2010. Also as shown in Fig. 11, when the fold-down flap 2307 is in the extended position, the insulating device 2010 can approximate a trapezoidal shape for providing an elongated closure at the top of the

insulating device 2010.

[93] As shown in the side and cross-sectional views, i.e., Figs. 12 and 14A, the insulating device 2010 can approximate a pentagon, when the fold-down flap 2307 of the insulating device 2010 is in an extended position. This general shape may provide for an insulating device 2010 that may be easily shipped in that several insulating devices can be fit into a shipping container. Nevertheless, other shapes and configurations are contemplated e.g., square, rectangular, triangular, conical, curved, and frusto-shapes which may provide an extended closure at the top of the insulating device 2010 and that can be easily packaged.

[94] Like in the above examples, the insulating device 2010 may include an outer shell 2501, an inner liner 2500 forming a storage compartment, a receptacle, or inner chamber 2504 and an insulating layer 2502 positioned in between the outer shell 2501 and the inner liner 2500. The insulating layer 2502 provides insulation for the storage compartment 2504. The closure 2311 can be configured to substantially seal an opening 2512, which is located on an angled front facing surface and extends through the outer shell 2501 and the inner liner 2500 to provide access to the storage compartment 2504. Also, the closure 2311 can include similar features and functionality in accordance with the examples discussed above. In one example, the closure 2311 can be a zipper and can be substantially waterproof so as to resist liquid from exiting the opening when the insulating device 2010 is in any orientation. Also, similar to the above examples, the insulating device 2010 can be provided with one or more of carry handles 2210, shoulder straps 2218, webbing loops 2224 formed with threads 2222 by stitching for example, rings 2214, and attachment points 2213 which can have similar features and functionality as in the examples above.

[95] As shown in Figs. 11 and 12 and as noted above, the fold-down flap 2307 may include the front facing closure 2311 and can be folded over and secured to a sidewall of the insulating device 2010 to further insulate the front facing closure 2311. The fold-down flap 2307 of the fastening mechanism 2301 can include first and second end hooks or clips 2313a, 2313b. In one example, each of the end clips 2313a, 2313b can include a slot 2317a, 2317b for being received in corresponding loops 2315a, 2315b located on the sides or the sidewalls of the insulating device 2010. To close the insulating device 2010, the fold-down flap 2307 along with the front facing closure 2311 are folded over onto a front face or wall of the insulating device 2010. The fold-down flap 2307 folds over with and conceals or covers the front facing closure 2311. The fold-down flap 2307 is held into place by the first and second end clips 2313a, 2313b and maintains the

fastening mechanism 2301 in the closed position. Additionally, when the fold-down portion 2307 is secured to the sidewalls of the insulating device 2010, the fold-down portion 2307 extends at least partly in a substantially horizontal direction, which orients a carrying handle 2318 in position for a user to grasp for holding and carrying the insulating device 2010. As in the other handles and straps, the carry handle 2318 can be secured to the outer shell with a reinforcement patch (not shown). The carry handle 2318 can be provided on the rear surface of the insulating device 2010 to oppose the closure 2311 on the front facing surface, which can be used by the user to grasp during opening and closing the insulating device 2010 to make it easier for the user to open and close the closure 2311. The carry handle 2318 may also be used for hanging the insulating device 2010, or for carrying the insulating device 2010; however, other uses are also contemplated.

[96] Fig. 14A shows a cross-sectional side view of the insulating device 2010. The insulating device 2010 includes an inner liner 2500, an insulating layer 2502, and an outer shell 2501. As shown in Fig. 14A, like in the above examples, the insulating layer 2502 can be located between the inner liner 2500 and the outer shell 2501, and can be formed as a foam insulator to assist in maintaining the internal temperature of the receptacle 2504 for storing contents desired to be kept cool or warm. Also the insulating layer 2502 can be located in between the inner liner 2500 and the outer shell 2501, and can be unattached to either the inner liner 2500 or the outer shell 2501 such that it floats between the inner liner 2500 and the outer shell 2501. In one example, the inner liner 2500 and the outer shell 2501 can be connected at the top portion of the insulating device 2010 such that the insulating layer 2502 can float freely within a pocket formed by the inner liner 2500 and the outer shell 2501.

[97] In this example, the inner layer or inner liner 2500 can be formed of a first inner liner sidewall portion 2500a and a bottom inner liner portion 2500b. The first inner liner sidewall portion 2500a and the bottom inner liner portion 2500b can be secured together, by for example welding, to form the chamber 2504. Like in the above example, the chamber 2504 can be a “dry bag,” or vessel for storing contents. In one example, a tape, such as a TPU tape, can be placed over the seams joining the sections of the chamber 2504, after the first inner liner sidewall portion 2500a and the bottom inner liner portion 2500b are secured or joined together. The tape seals the seams formed between the first inner liner sidewall portion 2500a and the bottom inner liner portion 2500b to provide an additional barrier to liquid to prevent liquid from either entering or exiting

the chamber 2504. The inner liner 2500 can, thus, either maintain liquid in the chamber 2504 of the insulating device 2010 or prevent liquid contents from entering into the chamber 2504 of the insulating device 2010. It is also contemplated, however, that the inner liner 2504 can be formed as an integral one-piece structure that may be secured within the outer shell.

[98] As shown in both Figs. 14A and 15, the insulating layer 2502 can be formed of a first portion or an upper portion 2502a, a second portion or base portion 2502b, and a base support layer 2505. In addition, the first portion 2502a can include a top flap or smaller rectangular shape 2502a1. When the fold-down flap 2307 is folded onto the top portion of the insulating device 2010, the top flap 2502a1 of the insulating layer together with the remainder of the first portion 2502a and the base portion 2502b surrounds substantially all of the inner chamber 2504 with insulation to provide a maximum amount of insulation to the inner chamber 2504 of the insulating device 2010.

[99] When the upper portion 2502a is rolled flat, the upper portion 2502a of the insulating layer 2502 generally resembles a “T” shape such that the insulating layer defines a first height H_1 and a second height H_2 where the first height H_1 is greater than the second height H_2 . In this example, a majority of the insulating layer can extend to the second height H_2 , which is less than the first height H_1 . Also, the first portion 2502a can be formed of two inter-connected rectangular shapes, where the bottom of the first portion 2502a forms a first larger rectangular shape 2502a2 and an upper section of the first portion 2502a forms the top flap 2502a1 of the smaller rectangular shape. It is also contemplated that the first larger rectangular shape 2502a2 can be formed as a separate piece from the smaller rectangular shape 2502a1. The first rectangular shape 2502a2 can have a first rectangular width and the second rectangular shape 2502a1 can have a second rectangle perimeter and first rectangular shape 2502a2 width approximates the second rectangular shape 2502a1 perimeter. In one example, the smaller rectangular shape 2502a1 forms a top flap of the insulation layer of the upper portion 2502a, which extends into the fold-down portion 2307.

[100] The first portion 2502a and the second portion 2502b can be formed of an insulating foam material as discussed herein. In one example, the second portion 2502b can be formed of a thicker foam material than the first portion 2502a. For example, the thickness of the second portion 2502b can be formed between 20 mm and 50 mm thick, and, in one particular example, can be formed of a 38 mm thick foam, and the first portion 2502a can be formed between 15 mm and 30 mm, and, in one particular example, can be formed of a 25 mm thick foam. In one

example, the foam can be a NBR/PVC blended foam, a PVC free NBR foam, or other eco-friendly type foam.

[101] Also as shown in Fig. 15, a base support layer 2505 adds to the insulation and the structural integrity of the insulating device 2010 at base 2215. The base support layer 2505 may also provide additional protection around the bottom of the insulating device 2010. In one example, the base support layer 2505 can be formed from EVA foam. The base support layer 2505 may include a certain design such as a logo or name that can be molded or embossed directly into the material. A base support ridge 2400, which provides structural integrity and support to the insulating device 2010 can also be molded or embossed directly into the base support layer 2505. In one example, the base support layer 2505 and the base portion 2502b can be detached or unsecured for ease of assembly in reducing the number of assembly steps. The base portion 2502b can be formed as an oval shape to close off a lower opening 2506 formed by the open shape of the upper portion 2502a.

[102] The bottom of the first portion 2502a maintains its form when folded into an oval-cylindrical shape and placed in between the inner liner 2500 and the outer shell 2501. The insulating layer 2502 maintains its shape which results in the basic oval-cylindrical shape of the insulating device 2010.

[103] The outer shell 2501 can be formed of an upper sidewall portion 2501a, a lower sidewall portion 2501b, and a base portion 2501c. Each of the upper sidewall portion 2501a, the lower sidewall portion 2501b, and the base portion 2501c can be secured by stitching. Other securing methods are also contemplated, such as, using welds or adhesives.

[104] Additionally, the fold-down portion 2307 can be at least partly free of foam to make it easier to close the fastening mechanism 2301. In particular, the fold-down portion 2307 can include a first section 2307a and a second section 2307b. The first section 2307a can be free of the insulation layer 2502 and the second section can include the insulation layer 2502.

[105] Referring to Fig. 14B, like in the above examples, the closure 2311 can be mounted on a backing or fabric. In the case of a zipper this can be referred to as zipper tape 2306. Also, like in the above examples, the zipper tape 2306 can be attached between the inner liner 2500 and the outer shell 2501 and, in particular, the zipper tape 2306 can be secured to the upper sidewall portion 2501a of the outer shell and the first inner liner sidewall portion 2500a. As shown in Fig. 14B, the zipper tape 2306, the upper sidewall portion 2501a of the outer shell, and the first inner

liner sidewall portion 2500a can form a stacked arrangement of a sandwich structure where the zipper tape 2306 is located between the upper sidewall portion 2501a of the outer shell and the first inner liner sidewall portion 2500a.

[106] The insulating device 2010 can be formed using similar techniques in relation to the examples as discussed above. For example, the upper sidewall portion 2501a of the outer shell 2501 can be formed. Also the base 2215 can be formed separately with the base portion 2502b of the insulation layer 2502, the base support layer 2505, the lower sidewall portion 2501b, and a base portion 2501c of the outer shell 2501 according to the techniques discussed herein. The base 2215 can be secured to the bottom of the upper sidewall portion 2501a of the outer shell 2501 using the techniques discussed herein. The upper portion 2502a of the insulation layer 2502 can be placed within the upper sidewall portion 2501a of the outer shell 2501. The first inner liner sidewall portion 2500a and the bottom inner liner portion 2500b can then be secured to form the inner liner 2500 and chamber 2504. Tape, such as a TPU tape, can be placed over the seams joining the sections of the inner liner 2500 and chamber 2504. The inner liner 2500 can then be placed within the insulation layer 2502. The closure 2311 can then be attached between the inner liner sidewall portion 2500a and the upper sidewall portion 2501a. At this point in the process the insulating device 2010 assembly will have a cylindrical shape with an open top. To close the open top, the upper ends of the inner liner sidewall portion 2500a and the upper sidewall portion 2501a can then be secured together by welding or by using any of the techniques discussed herein to form the insulating device 2010. A binding 2518 can be applied to the top portion of the insulating device 2010 to cover and conceal the seam between the outer shell 2501 and the inner liner 2500. The loop patch (not shown), carry handles 2210, shoulder strap 2218, webbing loops 2224, and rings 2214 can be added to the outer shell 2501 by the various techniques discussed herein, after the formation of the outer shell or once the insulating device 2010 is formed. It is contemplated that the inner liner and the outer liner can be formed by welding, gluing, or stitching and combinations thereof.

[107] In another example, a magnetic connection can be implemented for securing the fold-down portion 2307 to the body of the insulating device 2010. As shown in Figs. 16A and 16B, the insulating device 2010 can be provided with a magnetic clip 3313, which can be received by a corresponding magnet (not shown) on the sidewall of the insulating device 2010. However, it is also contemplated that the clip and clip receiving portion on the insulating device 2010 could

be one or more of permanent magnets, metal strips, or ferromagnetic materials. In addition, other methods of securing the fold-down flap 2307 over the front facing closure 2311 are also contemplated. For example, one or more of hook and loop, buckle, snap, zipper, detent, spring loaded detent, button, cams, or threads could be used to secure the fold-down flap 2307 to the sidewall of the insulating device 2010.

[108] Figs. 17-22 show another exemplary insulating device 4010. The example insulating device 4010 can be of a similar construction to the above examples and, in particular, the example discussed above in relation to Figs. 11-16B, where like reference numerals represent like features having the same or similar functionality. In this example, the insulating device 4010 does not include a fold-down flap and can include a different overall shape than the example insulating device 2010. Additionally, the insulating layer 4502 can have a different configuration along with other variations that will be discussed below. Like in the above example, the closure 4311 can be placed on a front face or wall of the insulating device 4010.

[109] As shown in Figs. 18 and 19, when viewed from the front and rear, the insulating device 4010 can generally form a trapezoidal shape, where the insulating device diverges or tapers upward toward the top of the insulating device 4010. The trapezoidal shape may provide certain insulation, user accessibility, and packaging benefits. For example, the trapezoidal shape can provide an extended period of ice coverage because of the additional foam that can be placed between the outer shell 4501 and the inner liner 4500 due to the trapezoidal shape.

[110] Additionally, the overall shape of the insulating device 4010 can help to maintain the insulating device 4010 in the opened position when the closure 4311 is in the opened position and permits the user to be able to easily access the contents of the insulating device 4010. The trapezoidal shape as discussed herein also allows the closure 4311 to be formed longer relative to the insulating device 4010. Other shapes that allow for an extended opening at the upper portion of the insulating device 4010 are also contemplated. For example, the upper portion of the insulating device 4010 could be formed with an extended curvature either upward or downward to allow for a larger closure extending across the upper portion of the insulating device 4010. Also as shown in Fig. 20, when viewed from the side, the insulating device 4010 can be formed generally conical, tapered or funnel-shaped such that the sides converge to the top of the insulating device 4010. Also the sides can be formed substantially parabolic in shape in certain examples. Therefore, the insulating device 4010 converges to an apex along the top of the insulating device

4010 as opposed to an oval shape with the same perimeter as the bottom of the insulating device 4010.

[111] In certain examples, a trapezoidal shape may also provide for an insulating device 4010 that may be easily shipped in that several insulating devices 4010 can be fit into a shipping container. For example, multiple insulating devices 4010 could be arranged in a shipping container in different orientations so as to utilize more space within a shipping container.

[112] In alternative embodiments, when the closure 4311 is in the opened or unsealed position, the contents in the insulating device 4010 may maintain the closure 4311 in the open position for easier access to the contents of the insulating device 4010. In this example, the weight of the contents can force a lower half of the closure 4311 away from an upper half of the closure 4311 such that the user can better see the contents of the insulating device 4010 and more easily remove the contents or add contents to the insulating device 4010.

[113] In this example, the outer shell construction, insulating layer, and the inner liner construction can be similar to that of the embodiment discussed above in relation to Figs. 11-16B, the details of which are not repeated here. The outer shell 4010 may also include a top portion 4316, which is configured to receive the closure 4311 therein. The top portion 4316 can be formed of the same material as the remaining outer shell 4501, which in one specific example, can be nylon and specifically an 840d nylon with TPU.

[114] Similar to the example discussed in relation to Figs. 11-16B, the insulating device 4010 can be provided with one or more of carry handles 4210, a shoulder strap 4218, webbing loops 4224, which are formed by threads 4222, rings 4214, and attachment points 4213 which can have similar features and functionality as in the examples above. Additionally, a rear carry handle 4318 can be provided on the rear surface of the insulating device 4010 to oppose the closure 4311, which can be used by the user to grasp during opening and closing the insulating device 4010 to make it easier for the user to open and close the closure 4311. The rear carry handle 4318 may also be used for hanging the insulating device 4010 for drying the inner chamber 4504, or for carrying the insulating device 4010. Each of the carry handles 4210, shoulder strap 4218, webbing loops 4224, and attachment points 4213 can be reinforced by one or more of additional structures in the form of webbing or suitable polymeric materials. This reinforcement material may be applied to any of the examples discussed herein.

[115] Also as shown in Figs. 17 and 21 a binding 4518 can be included that extends over the

top of the insulating device 4010 to secure the outer shell 4501 to the inner liner 4500. The binding 4518 can be folded over the top of the insulating device 4010 and then stitched over the over outer shell 4501 and the inner liner 4500 to form a cover to the joint or seam between the inner liner 4500 and the outer shell 4501. As shown in Fig. 18, the binding 4518 can be folded into thirds to form a first folded portion 4518a where the first third is attached to a first side of the insulating device 4010, the second third is extends over the top of the insulating device 4010, and the last third is attached to a second side of the insulating device 4010. The binding 4518 covers the seam between the outer shell 4501 and the inner liner 4500 along the top of the insulating device 4010. Also, as shown in Fig. 17, the binding 4518 extends from the top of the insulating device 4010 and forms a second folded portion 4518b where the binding 4518 is folded in half and a third unfolded portion 4518c, which forms and extends to attachment points 4213 that receive rings 4214. Each side of the insulating device 4010 can include a second folded portion 4518b and a third unfolded portion 4518c such that the insulating device 4010 can include two second folded portions 4518b and two third unfolded portions 4518c. The binding 4518 can unfold closer to the attachment points 4213 and may also be formed unfolded from the attachment points 4213 to the top of the insulated device 4010. In either of these configurations, a section of the binding 4518, e.g., the second folded portion 4518b, can be unattached to the insulating device 4010 and forms a strap between the folded portion 4518a and the attachment points 4213. In this example, two straps can be formed by the two second unfolded portions 4518b and can be grasped by the user for handling the insulating device, can be used for hanging the insulating device 4010 for drying, and the like. Also, the attachment points 4213 formed by the binding 4518 can be a loop or slot for receiving the rings 4214.

[116] Figs. 22 and 22A show the insulating layer 4502 in additional detail, which is similar to the example insulating device 4010 discussed above where like reference numerals represent like components with the same or similar functionality. The insulating layer 4502 can be formed of the materials as discussed herein and, in certain examples, can be PVC free and/or can have non-thermoset properties such that the foam is fully resilient. Like the above examples, the upper portion 4502a of the insulating layer 4502 can be formed of a single sheet of material which is rolled into the shape defined by the opening between the inner liner 4500 and the outer shell 4501. As shown in Fig. 22, the insulating layer 4502, like in the above examples, can be formed of a first portion or an upper portion 4502a and a second portion or base portion 4502b. The

rear top flap 4502a1 can be formed in smaller rectangular shape. The rear top flap 4502a1 extends higher than the front side of the first portion 4502a of the insulating layer 4502a to accommodate for the front facing closure 4311. Specifically, the rear top flap 4502a1 can extend to a first height H_3 , and the first portion 4502a can extend to a second height H_4 , and the first height H_3 can be greater than the second height H_4 . Additionally, as shown in Fig. 22, a majority of the insulating layer 4502 can extend to the second height H_4 . Alternatively, as shown in Fig. 22A, the rear half of the insulating layer 4502 can extend to the first height H_3 and the front half of the insulating layer 4502 can extend to the second height H_4 . Additionally, as shown in Fig. 22A, the insulating layer 4502 can taper from the first height H_3 to the second height H_4 . Also, this provides the areas of the insulating layer 4502 near the top with tapered or chamfered portions along the sides of the insulating device 4010 to provide a smaller profile on each side of the insulating device 4010.

[117] In one example, the first portion 4502a can define a first area A_1 , and the rear top flap 4502a1 can define a second area A_2 , which is smaller than the first area A_1 . When installed between the inner liner 4500 and the outer shell 4501, the insulating layer 4502 generally follows the conical and trapezoidal shape of the profile of the insulating device 4010. Additionally, the upward tapered profile of the outer shell 4501 and the inner liner 4500 can help to position the insulating layer 4502 such that the insulating layer covers a majority of the inner liner 4500.

[118] In particular, as shown in Fig. 21, the insulating layer 4502 occupies a majority of the space formed between the inner liner 4500 and the outer shell 4501. The insulating layer 4502 extends substantially to the top of the insulating device 4010 in both the front and the rear portions of the insulating device 4010 to insulate a majority of the compartment 4504. As a result, the insulating layer 4502 surrounds substantially the entire inner chamber 4502 to provide a maximum amount of insulation to the inner chamber 4504 of the insulating device 2010. In one example, the insulating layer 4502 covers 80% or more of the inner liner 4500 covering the inner chamber 4504, and in particular examples the insulating layer 4502 covers 85%, 90%, or 95% or more of the inner liner 4500 covering the inner chamber 4504.

[119] In the examples discussed in relation to Figs. 11-22, the front facing closures 2311, 4311 can be formed such that they extend a majority of the way along the front facing surface of the insulating devices 2010, 4010. As discussed above, the front-facing closures 2311, 4311 can be formed as zipper closures in accordance with the examples discussed herein. In one example, the

closures 2311, 4311 can be substantially waterproof or highly water resistant and can be water tight and air tight. The front facing closures 2311, 4311 can be formed as long as possible in the front facing surface of the insulating devices 2010, 4010 to provide for extended user accessibility and visibility of the contents stored in the insulating devices 2010, 4010. In one example, the closures 2311, 4311 can define a first length L_1 , and the top portion of the insulating device 4010 can define a second length L_2 .

[120] In one example, L_2 can be 3 cm to 10 cm longer than L_1 , the length of the front facing closures 2311, 4311 and in one specific example can be 5 cm longer than the front-facing closures 2311, 4311. The closures 2311, 4311 first length L_1 can extend at least 80% of the second length L_2 and up to 98% of the second length L_2 . In one particular example, the length of the closures 2311, 4311, L_1 can extend across 87% of the second length L_2 .

[121] Additionally, the length L_1 of the front-facing closures 2311, 4311 can be formed longer than the length L_3 of the bases of the insulating devices 2010, 4010. In certain examples, the front facing closures 2311, 4311 can be formed approximately 1% to 25% longer than the length L_3 of the bases of the insulating devices 4010. In one specific example the length L_1 of the front facing closures 2311, 4311 can be 10% longer than the length L_3 of the bases. For example, the front-facing closures length L_1 can be formed 3 cm to 12 cm longer than the length L_3 of the bases of the insulating devices, and, in one particular example, the length L_1 of the front facing closures 2311, 4311 can be 5 cm longer than the length L_3 of the base.

[122] In still other embodiments, the insulating device can include a closure that extends around the entire perimeter or a majority of the perimeter of the insulating device and a front facing closure 2311, 4311 as discussed above. In this particular example, the contents of the insulating device can be easily accessed by the user once the entire or a majority of the top portion is removed or through the closure 2311, 4311.

[123] In another example, the insulating device can be formed modular such that the top and/or the bottom can be removed and multiple structures can be interconnected to form larger or smaller insulating devices. For example, the insulating device can be formed of different sections by way of removable fasteners, such as snaps, zippers, threads, seals, hook and loop, and the like.

[124] In relation to the examples discussed herein, a series of vents can be provided along the outer shells of the insulating devices. The vents allow for any gases that are trapped between the inner liner and the outer shell to escape. Without the vents, the gases trapped between the inner

liner and the outer shell can cause the insulating device to expand, which in certain instances, may not be desired. In certain examples, the one or more joints or seams that connect the various portions of the outer shell provide vents for gases. Vents can be provided in areas of the outer shell where the outer shell fabric is pierced. For example, tiny openings can be provided at any of the stitching locations where the various components are located on the insulating devices. Specifically, the vents can be provided in the areas where the handles, molle loops, straps, reinforcement patches, bindings, D-rings, loop patches, etc. are attached to the outer shell of the insulating device. For example, stitching that may be used to secure these components to the outer shell provides openings into the outer shell, which creates venting between the insulation layer and the outer shell. In one specific example, the insulating device may vent through binding 4518.

[125] The example insulating device 4010 was tested to determine ice retention. As such, the ice retention testing may be utilized to determine insulative properties of example insulating device 4010. In an exemplary test, the duration of the increase from 0°F to 50°F when the insulating device 4010 was filled with ice was determined according to the test parameters below. In certain examples, the temperature of the insulating device increases from 10°F to 32°F in a duration of 24 hours to 24 hours, the temperature of the insulating device increases from 32°F to 50°F in a duration of 36 hours to 68 hours, and the temperature of the insulating device increases from 0°F to 50°F in a duration of 70 hours to 90 hours.

[126] The ice retention was tested using the following test. More than 24 hours before the test, the following steps are performed:

- Ensure test coolers are clean inside and out.
- Mark test coolers with unique identifier and record identifier and description in test log or notes.
- Using duct tape, place a thermocouple (T) in the approximate center of the test cooler (C).
- The thermocouple tip should be approximately 1 inch above the cooler floor. (See Fig. 23 for an example of proper thermocouple set-up.)
- Condition test coolers by keeping test coolers inside (ambient temperature 65-75° F) with lids open for a minimum of 24 hours.
- Calculate the amount of ice required for testing (to nearest 0.1 lbs.) using the equation below.

- Ice per cooler = 0.52 lbs. x Quart capacity of cooler
- Ice required = Ice per cooler x number of coolers
- Condition the ice by placing the ice in a freezer (-15 to -5 °F) for a minimum of 24 hours prior to use.

[127] The day of the test, the following steps are performed:

- Gather Test Equipment
- Allow thermal chamber to reach a temperature of 100°F
- Scale – place scale near freezer with test ice
- Data Logger – ensure Data Logger has charged battery

[128] The test procedure is as follows:

- Bring test coolers to freezer with test ice.
- Place test cooler on scale and tare the scale.
- Break test ice with hammer.
- Using the scale as reference, quickly fill the test cooler with the required amount of ice.
- Ensure that the ice is evenly distributed throughout the test cooler.
- Ensure that the connector end of the thermocouple is outside of the test cooler and close and secure the cooler lid.
- Repeat steps for the remaining test coolers.
- Arrange the coolers in the test area such that they all have even amounts of direct sunlight and airflow (one cooler does not block the other).
- Connect all thermocouples to the data logger.
- Check all thermocouple readings to ensure that all connections are complete and the channels are recording properly. (Note: The starting temperature inside each test cooler should be < 10° F).
- Power up the data logger and configure to record with temperatures recorded at less than 10 minute intervals.

- Begin recording and note time in test log.
- Allow the test to continue until the inside temperature of each test cooler is ≥ 50 °F.
- Stop recording.
- Disconnect thermocouples from data logger.
- Receive data from data logger.
- Remove test coolers from test area.
- Empty test coolers and allow them to dry.
- Remove thermocouples from test coolers

[129] The heat gain rate of the insulating devices 2010, 4010 can be approximately 0.5 to 1.5 degF/hr, and, in one particular example, the heat gain rate can be approximately 1.0 degF/hr.

[130] Like in the above examples, the ability of the insulating devices 2010 and 4010 are also configured to withstand interior leaks and were also tested to see how well the insulating devices 2010, 4010 maintain the contents stored in the storage compartment or receptacles 2504, 4504. In one example test, the insulating devices 2010, 4010 can be filled with a liquid, such as water, and then can be inverted for a predetermined time period to test for any moisture leaks. In this example, the insulating devices 2010, 4010 are filled with a liquid until approximately half of a volume of the receptacle 4504 is filled, e.g. 3 gallons of water, and the closures 2301, 4301 are then closed fully. The entire insulating devices 2010, 4010 are then inverted and held inverted for a time period of 30 minutes. The insulating devices 2010, 4010 are then reviewed for any leaks.

[131] The insulating devices 2010, 4010 can be configured to withstand being held inverted for 30 minutes without any water escaping or leaving the receptacles 2504, 4504. In alternative examples, the insulating devices 2010, 4010 can be configured to withstand being held inverted for 15 minutes to 120 minutes without any water escaping or leaving the receptacles 2504, 4504.

[132] An exemplary insulating device may include an outer shell, an inner liner, an insulating layer floating freely in between the outer shell and the inner liner, and a waterproof closure. The top of the shell has first perimeter circumference, and the bottom of the shell has a second perimeter circumference. The first perimeter circumference can be equal to the second perimeter circumference. The closure can be a zipper assembly comprising a plurality of zipper teeth, and the zipper teeth can be formed of plastic or metal. The outer shell can be made of a double laminated TPU nylon fabric. The inner liner can be made of a double laminated TPU nylon fabric. The insulating layer can be formed of a closed cell foam. The insulating layer can be made of a

NBR and a PVC blend, and at least a portion of the insulating layer can be constructed with an EVA foam layer. The outer shell further can include at least one of a strap or handle. The outer shell further can include at least one ring for securing the insulating device.

[133] An exemplary insulating device can include an outer shell, an inner liner, a closure adapted to seal at least one of the outer shell or the inner liner, and an insulating layer between the outer shell and the inner liner. The closure can have a first flange and a second flange, and the outer liner can be secured to top surfaces of the first flange and the second flange and the inner liner can be secured to bottom surfaces of the first flange and the second flange. The outer liner and the inner liner can be connected to the closure by a polymer weld. The outer shell can have a first circumference and a second circumference, the first circumference and the second circumference both having an oval shape. The closure can be adapted to be a barrier against fluid. The closure can be a zipper apparatus that is watertight up to 7 psi above atmospheric pressure.

[134] An exemplary method of assembling a insulating device may include forming an inner liner having an inner vessel, forming an outer shell, forming an insulating layer between the inner liner and the outer shell, and securing a closure configured to be a barrier against fluid penetration in and out of the inner vessel wherein the closure is secured in a flat plane and is secured to the outer shell and the inner shell. The outer shell and inner shell may only be connected to the closure and not to the insulating layer between the outer shell and inner liner.

[135] A waterproof polymer weld can be formed between the closure and the inner shell and the closure and the outer shell when the closure, the outer shell, and the inner liner are lying in a horizontal plane. The outer shell and the inner layer can be formed of a TPU nylon material. The closure can have a first flange and a second flange. The outer liner can be secured to top surfaces of the first flange and the second flange and the inner liner can be secured to bottom surfaces of the first flange and the second flange.

[136] The method can also include forming the insulating layer from a rectangular shape, and rolling the rectangular shape into a cylindrical shape. The top of the insulating layer has a first perimeter circumference and the bottom of the insulating layer has a second perimeter circumference. The first perimeter circumference can be equal to the second perimeter circumference.

[137] Another example insulating device can include an outer shell, an inner liner forming a storage compartment, a foam layer floating freely in between the outer and inner liner, the foam

layer providing insulation, an opening extending through the outer layer and the inner layer, and a closure adapted to substantially seal the opening. The closure can be substantially waterproof so as to resist liquid from exiting the opening.

[138] The insulating device can also include an upper wall and a base, the upper wall defining an upper wall circumference, an upper wall length and an upper wall width, and the base defining a base circumference, a base length and a base width. The upper wall circumference can be equal to the base circumference and the ratio of the upper wall length to the upper wall width can be greater than the ratio of the base length to the base width. In one example, a heat gain rate of the insulating device can be approximately 1.0-1.5 degF/hr.

[139] Another example method of forming an insulating device may include forming an inner liner first portion and an outer shell first portion, securing the inner liner first portion and the outer shell first portion to a sealable closure to form a cap assembly, forming an inner liner second portion and securing the inner liner second portion to the inner liner first portion to form an inner liner, forming an outer shell second portion, rolling a rectangular foam portion to form a first cylindrical foam portion and securing a foam base portion to the first cylindrical portion to form a foam assembly, inserting the foam assembly into the outer shell second portion, inserting the inner liner into the foam assembly, and stitching the outer shell first portion to the outer shell second portion. The inner liner first portion and the outer shell first portion can be welded to the closure. The closure can be provided with at least one flange and the flange can be secured to a bottom surface of the outer shell first portion and a top surface of the inner liner first portion. The foam can float between the outer shell second portion and the inner liner second portion.

[140] An example portable insulating device may include an outer liner, an inner liner forming a storage compartment, a foam layer in between the outer and inner liner. The foam layer can be adapted to provide insulation. The example portable insulating device may also include an opening extending through one of the outer layer and the inner layer and a closing means for substantially sealing the opening. The closure can be substantially waterproof.

[141] In one example, a portable cooler may include an aperture on the top of the cooler that is opened and closed by a zipper apparatus which allows access to a chamber within the cooler. The aperture prevents any fluid leakage out of the cooler if the cooler is overturned or in any configuration other than upright. The zipper assembly also prevents any fluid from permeating

into the cooler chamber if the cooler is exposed to precipitation, other fluid, or submersed under water.

[142] An example method of assembling a zipper apparatus and aperture configured to be impervious to water or other liquids and fluids can include attachment of a waterproof zipper via material welding to both an outer shell and an inner liner. This method may result in a chamber impervious to water and other liquids when the zipper apparatus on the aperture is sealed.

[143] In one example, an insulating device may include an outer shell, an inner liner forming a storage compartment, a foam layer floating formed in between the outer and inner liner, the foam layer providing insulation, an opening extending through the outer layer and the inner layer, a closure adapted to substantially seal the opening, the closure being substantially waterproof so as to resist liquid from exiting the opening when the insulating device is in any orientation. In one example, the top portion of the outer shell can have a first perimeter circumference in a first configuration. The outer shell may include a bottom portion, the bottom portion of the outer shell can have a second perimeter circumference in a second configuration that is different from the first configuration, and the first perimeter circumference can be equal to the second perimeter circumference. The first configuration and the second configuration can be both oval shaped. In one example, the insulating device may include an upper wall and a base, the upper wall can define an upper wall circumference, an upper wall length and an upper wall width, and the base can define a base circumference, a base length and a base width. The upper wall circumference can be equal to the base circumference and the ratio of the upper wall length to the upper wall width can be greater than the ratio of the base length to the base width. The cold retention time of the insulating device can be approximately 11 to 20 hours. However, in one example the cold retention time can be 11 to 15 hours. In another example the cold retention time can be approximately 12.24 hours. The heat gain rate of the insulating device can be approximately 1 to 1.5 degF/hr, and, in one particular example, the heat gain rate can be approximately 1.4 degF/hr. The storage compartment can be configured to maintain a liquid therein while inverted for greater than 15 minutes. In one particular example, the storage compartment can be configured to maintain the liquid for a period of greater than 30 minutes therein when inverted and a half of a volume of the storage compartment is filled with the liquid.

[144] In one example, the insulating layer can be floating freely in between the outer shell and the inner liner. The insulating layer can be formed of closed cell foam, and the insulating layer can

be made of a NBR and a PVC blend. In one example least a portion of the insulating layer can be constructed with an EVA foam layer. The closure can be a zipper assembly comprising a plurality of zipper teeth, and the zipper teeth can be formed of plastic.

[145] In one example, the outer shell and the inner liner can be made of a double laminated TPU nylon fabric. The outer shell further can include at least one of a strap or handle. The outer shell can include at least one ring for securing the insulating device. The insulating layer can be configured to maintain an internal temperature of the insulating device below 50 degrees Fahrenheit for 65 to 85 hours. The closure can be formed with a first flange and a second flange and the outer liner can be secured to top surfaces of the first flange and the second flange. The inner liner can be secured to bottom surfaces of the first flange and the second flange. The outer liner and the inner liner can be connected to the closure by a polymer weld. In one example, the closure can be watertight up to 2 to 14 psi above atmospheric pressure. A loop patch may also be provided on the insulating device.

[146] In another example, an insulating device may include an outer shell, an inner liner forming a storage compartment, a foam layer floating in between the outer and inner liner, which provides insulation, an opening extending through the outer layer and the inner layer, a closure adapted to substantially seal the opening. The closure can be substantially waterproof so as to prevent liquid from exiting the opening when the insulating device is inverted for a period of greater than 15 minutes. The heat gain rate of the insulating device can be approximately 1.0 to 1.5 degF/hr. The insulating device can include at least one handle. The at least one handle can be configured to support 100 lbs. to 300 lbs. of weight for 1 to 10 minutes without showing signs of failure. In one example, the insulating device can be configured to withstand 35 lbs. to 100 lbs. of puncture force.

[147] An example method of forming an insulating device can include forming an inner liner first portion and an outer shell first portion, securing the inner liner first portion and the outer shell first portion to a sealable closure to form a cap assembly, forming an inner liner second portion and securing the inner liner second portion to the inner liner first portion to form an inner liner, forming an outer shell second portion, rolling a rectangular foam portion to form a first cylindrical foam portion and securing a foam base portion to the first cylindrical foam portion to form a foam assembly, inserting the foam assembly into the outer shell second portion, inserting the inner liner into the foam assembly, and securing the outer shell first portion to the outer shell second portion

to form the outer shell. The method may also include securing a closure configured to be a barrier against fluid penetration in and out of the inner vessel and forming a waterproof polymer weld between the closure and the inner shell and the closure and the outer shell when the closure, the outer shell, and the inner liner are lying in a flat plane.

[148] In an example, the inner liner first portion and the outer shell first portion can be secured to the closure. The closure can be provided with at least one flange, and the flange can be secured to a bottom surface of the outer shell first portion and a top surface of the inner liner first portion. The foam can freely float between the outer shell second portion and the inner liner second portion. The outer shell and inner shell are only connected to the closure and not to the insulating layer between the outer shell and inner liner. The outer shell can be formed of a TPU nylon material, and the inner liner can be formed from a TPU nylon material. The closure can include a first flange and a second flange. The outer liner can be secured to top surfaces of the first flange and the second flange, and the inner liner can be secured to bottom surfaces of the first flange and the second flange. The top of the insulating layer can have a first perimeter circumference. The bottom of the insulating layer can have a second perimeter circumference. The first perimeter circumference can be equal to the second perimeter circumference.

[149] In one example, an insulating device can include an outer shell defining a sidewall, an inner liner forming a storage compartment, an insulating layer positioned in between the outer shell and the inner liner, the insulating layer providing insulation for the storage compartment, an opening extending through the outer shell and the inner liner, and a closure adapted to substantially seal the opening, the closure being substantially waterproof so as to resist liquid from exiting the opening when the insulating device is in any orientation. The insulating device may include a vertically extending front facing surface and the closure can be located on the front facing surface. A cross section of the insulating device can approximate a pentagon in an extended position, and a cross section of the insulating device can approximate a trapezoid in an extended position. The insulating device may also include a base, and the insulating layer can insulate the base. The base may also include an additional insulating layer.

[150] The insulating device may also include a fold-down portion configured to cover the closure. The fold-down portion comprising a first section and a second section and wherein the first section is free of the insulation layer and the second section includes the insulation layer. The fold-down portion can be at least partially free of foam. The fold-down portion can be

configured to be secured to the sidewall. The fold-down portion can include at least one hook and the sidewall can include at least one loop. The hook can be configured to engage the loop to secure the fold-down portion to the sidewall. The fold-down portion can be secured to the sidewall, and the fold-down portion may extend at least partly in a substantially horizontal direction. The fold-down portion may define a first width, and the closure extends across at least 95% of the first width. The fold-down portion may also include a handle configured to be grasped by a user when the fold-down portion is secured to the sidewall.

[151] The insulating layer may include a foam material. The insulating layer may include a first portion and a second portion, and the second portion can be formed thicker than the first portion. The insulating layer can be at least partly formed in a shape of a T. The insulating layer can be at least partly formed of a first rectangle and a second rectangle and the first rectangle can have a larger area than the second rectangle. The first rectangle can have a first rectangle width and the second rectangle can have a second rectangle perimeter. The first rectangle width can approximate the second rectangle perimeter. The second rectangle can extend into the fold-down portion. The insulating layer can have a first height and a second height and the first height can be greater than the second height. A majority of the insulating layer can extend to the second height.

[152] A method of forming an insulating device may include forming an inner liner defining a storage compartment, forming an outer shell defining a sidewall, placing an insulating layer in between the outer shell and the inner liner, the insulating layer providing insulation for the storage compartment, placing an opening in the inner liner and the outer shell, and placing a closure between the inner liner and the outer shell. The closure can be adapted to substantially seal the opening, and the closure can be substantially waterproof so as to resist liquid from exiting the opening when the insulating device is in any orientation. The method may also include forming a fold-down portion configured to cover the closure, providing the fold-down portion with a first section and a second section. The first section can be free of the insulation layer and the second section can include the insulation layer. The fold-down portion can be at least partially free of foam. The fold-down portion can be configured to secure to the sidewall. The method may also include forming the insulating layer at least partly in the shape of a T, forming the insulating layer at least partly of a first rectangle and a second rectangle, and forming the first rectangle of a larger area than the second rectangle. The method may also include extending the second rectangle into

the fold-down portion and providing the insulating layer on a base and providing an additional insulating layer along the base.

[153] In another example, an insulating device can include an outer shell defining a sidewall, an inner liner forming a storage compartment, and an insulating layer positioned in between the outer shell and the inner liner. The insulating layer can provide insulation for the storage compartment. The insulating device can include an opening configured to allow access to the storage compartment and a closure adapted to substantially seal the opening. The insulating device can include a binding material, and the binding material can be placed over a joint between the inner liner and the outer shell. The binding material can be stitched onto the insulating device, and the stitching can create openings into the outer shell for venting air trapped between the insulating layer and the outer shell. The binding material can create at least one strap for holding the insulating device. The binding material can include a first folded portion attached to the outer shell and a second folded portion, and the second folded portion can form a strap.

[154] The insulation device can approximate a trapezoid from a front view and can approximate a conical shape from a side view. In one example, the insulating device increases from 0°F to 50°F in a duration of 70 hours or greater when filled with 0.52 lbs. of ice per each quart in capacity of the insulating device.

[155] The closure can be substantially waterproof so as to resist liquid from exiting the opening when the insulating device is in any orientation. In one example, the insulating device can be configured to withstand being held inverted for 15 minutes without any water escaping or leaving the storage compartment. The closure can be configured to stay in the opened position when the closure is not sealed. The closure can be a zipper. In one example, the closure extends at least 80% of the length of the insulating device when measured along the closure. The length of the closure can be longer than the length of the bottom of the insulating device, and the length of the closure is at least 5% longer than the length of the bottom of the insulating device. The insulating device can include a vertically extending front facing surface, and the closure can be located on the front facing surface. A handle can be located on a rear facing surface opposing the front facing surface.

[156] In the example insulating device, the insulating layer can comprise a foam material. The insulating layer can comprise a first portion and a second portion, and the second portion can be formed thicker than the first portion. The insulating layer can be at least partly formed of a first

rectangle and a second rectangle, and the first rectangle can have a larger area than the second rectangle. The insulating layer can have a first height and a second height, and the first height can be greater than the second height. In one example, a majority of the insulating layer can extend to the second height. In addition or alternatively, the front of the insulating layer can extend to the second height and the rear of the insulating layer extends to the first height. The insulating device can include a base, and the insulating layer can insulate the base. Also the base can include an additional or separate insulating layer. In one example, the insulating layer can cover 80% or more of the inner liner covering the storage compartment or the insulating layer can cover 90% or more of the inner liner covering the storage compartment.

[157] In another example, a method of forming an insulating device may include forming an inner liner the inner liner defining a storage compartment, forming an outer shell defining a sidewall, placing an insulating layer in between the outer shell and the inner liner, the insulating layer providing insulation for the storage compartment, placing an opening in the inner liner and the outer shell, placing a closure between the inner liner and the outer shell, the closure adapted to substantially seal the opening, the closure being substantially waterproof so as to resist liquid from exiting the opening when the insulating device is in any orientation. The method can also include forming the insulating layer at least partly of a first rectangle and a second rectangle and forming the first rectangle of a larger area than the second rectangle. The method can also include providing the insulating layer on a base and providing an additional insulating layer along the base.

[158] The present invention is disclosed above and in the accompanying drawings with reference to a variety of examples. The purpose served by the disclosure, however, is to provide examples of the various features and concepts related to the invention, not to limit the scope of the invention. One skilled in the relevant art will recognize that numerous variations and modifications may be made to the examples described above without departing from the scope of the present invention.

[159] Throughout this specification, unless the context requires otherwise, the word "comprise" or variations such as "comprises" or "comprising", will be understood to imply the inclusion of a stated element or integer or method step or group of elements or integers or method steps but not the exclusion of any element or integer or method step or group of elements or integers or method steps.

[0160] The reference in this specification to any prior publication (or information derived from it), or to any matter which is known, is not, and should not be taken as an acknowledgement or admission

or any form of suggestion that the prior publication (or information derived from it) or known matter forms part of the common general knowledge in the field of endeavour to which this specification relates.

THE CLAIMS DEFINING THE INVENTION ARE AS FOLLOWS:

1. An insulating device having a front, a rear, and a base, wherein the insulating device is configured to stand upright from the base, comprising:

an outer shell defining a sidewall and the base, the outer shell having a front portion and a rear portion;

an inner liner forming a storage compartment, the inner liner having a front portion and a rear portion;

an insulating layer positioned in between the outer shell and the inner liner, the insulating layer providing insulation for the storage compartment;

wherein top portions of the front and rear portions of the outer shell and the front and rear portions of the inner liner are connected by a joint;

a vertically extending front facing surface on the front of the insulating device;

an opening configured to allow access to the storage compartment; and

a closure located on the front facing surface adapted to substantially seal the opening, the closure being substantially waterproof so as to resist liquid from exiting the opening when the insulating device is in any orientation;

wherein the insulating layer has a first height extending from the base and a second height extending from the base, wherein the first height is greater than the second height, and the insulating layer in the front of the insulating device extends to the second height and the insulating layer in the rear of the insulating device extends to the first height.

2. The insulating device of claim 1 further comprising a binding material and wherein the binding material is placed over the joint of the top portions of the inner liner and the outer shell.

3. The insulating device of claim 2 wherein the binding material is stitched onto the insulating device and the stitching creates openings into the outer shell for venting air trapped between the insulating layer and the outer shell.

4. The insulating device of claim 2 wherein the binding material creates at least one strap for

holding the insulating device.

5. The insulating device of claim 2 wherein the binding material comprises a first folded portion attached to the outer shell, a second folded portion and wherein the second folded portion forms a strap.

6. The insulating device of any preceding claim wherein the closure is a zipper.

7. The insulating device of any preceding claim wherein the closure extends at least 80% of the length of the insulating device when measured along the closure.

8. The insulating device of any one of claims 1 to 6 wherein the length of the closure is longer than the length of the bottom of the insulating device.

9. The insulating device of claim 8 wherein the length of the closure is at least 5% longer than the length of the bottom of the insulating device.

10. The insulating device of any preceding claim wherein a handle is located on a rear facing surface opposing the front facing surface.

11. The insulating device of any preceding claim wherein the insulating layer comprises a foam material.

12. The insulating device of any preceding claim wherein the insulating layer comprises a first portion and a second portion wherein the second portion is formed thicker than the first portion.

13. The insulating device of any preceding claim wherein the insulating layer is at least partly formed of a first rectangle and a second rectangle and wherein the first rectangle has a larger area than the second rectangle.

14. The insulating device of any preceding claim wherein the insulation device approximates a

trapezoid from a front view.

15. The insulating device of any preceding claim wherein the insulating device approximates a conical shape from a side view.

16. The insulating device of any preceding claim wherein a majority of the insulating layer extends to the second height.

17. The insulating device of any preceding claim wherein the base comprises a separate insulating layer.

18. The insulating device of any preceding claim wherein the insulating device increases from 0°F to 50°F in a duration of 70 hours or greater when filled with approximately 0.52 lbs. of ice per each quart in capacity of the insulating device.

19. The insulating device of any preceding claim wherein the insulating device is configured to withstand being held inverted for 15 minutes without any water escaping or leaving the storage compartment.

20. The insulating device of any preceding claim wherein the insulating layer covers 80% or more of the inner liner covering the storage compartment.

21. The insulating device of claim 20 wherein the insulating layer covers 90% or more of the inner liner covering the storage compartment.

22. A method of forming an insulating device having a front, a rear, a base having a bottom perimeter, and a vertically extending front facing surface comprising:

forming an inner liner the inner liner defining a storage compartment; forming an outer shell defining a sidewall, the outer shell having a front portion and a rear portion;

placing an insulating layer comprising a first portion and a base portion, wherein the base portion is located in the base of the insulating device, in between the outer shell and the inner liner,

the insulating layer providing insulation for the storage compartment , wherein the first portion of the insulating layer has a first height and a second height, wherein the first height is greater than the second height, and the first portion of the insulating layer in the front of the insulating device extends to the second height and the insulating layer in the rear of the insulating device extends to the first height

connecting top portions of the front and rear portions of the outer shell and the front and rear portions of the inner liner with a joint;

placing an opening on the front facing surface in the inner liner and the outer shell; and

placing a closure between the inner liner and the outer shell, the closure adapted to substantially seal the opening, the closure being substantially waterproof so as to resist liquid from exiting the opening when the insulating device is in any orientation.

23. The method of claim 22 further comprising forming the insulating layer at least partly of a first rectangle and a second rectangle and forming the first rectangle of a larger area than the second rectangle.

24. The method of claim 22 or 23 further comprising providing the insulating layer on a base and providing an additional insulating layer along the base.

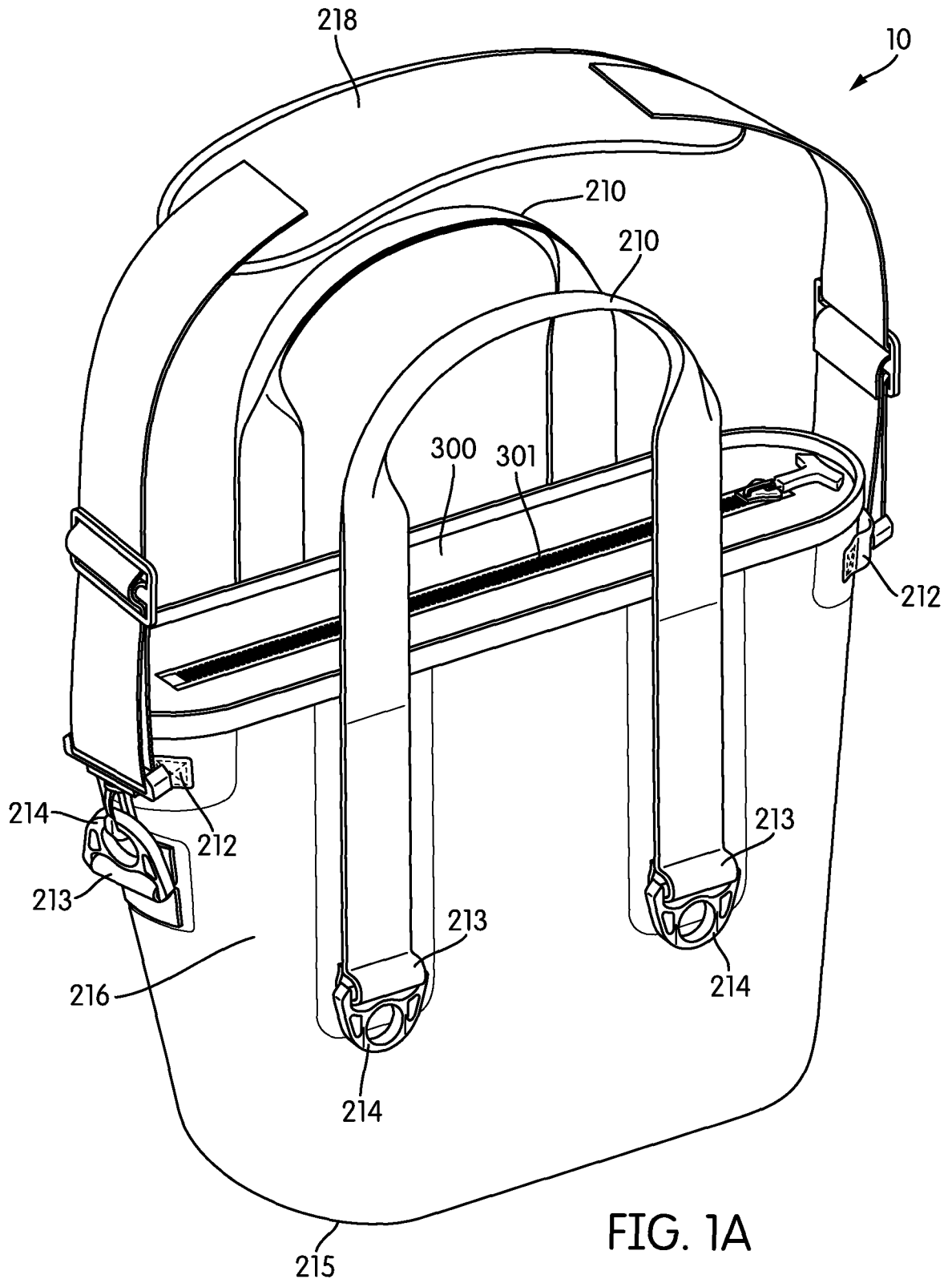

FIG. 1A

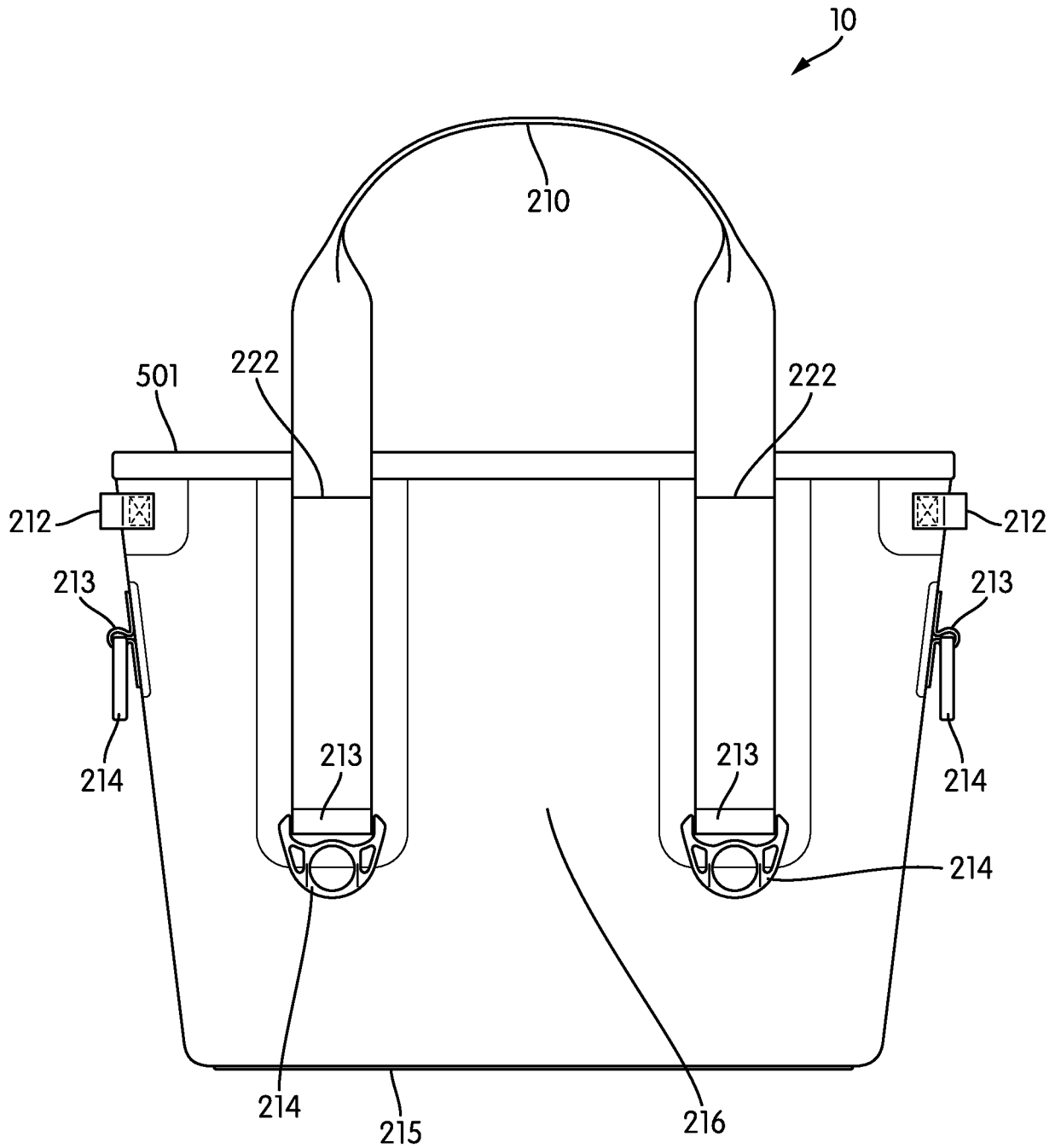

FIG. 1B

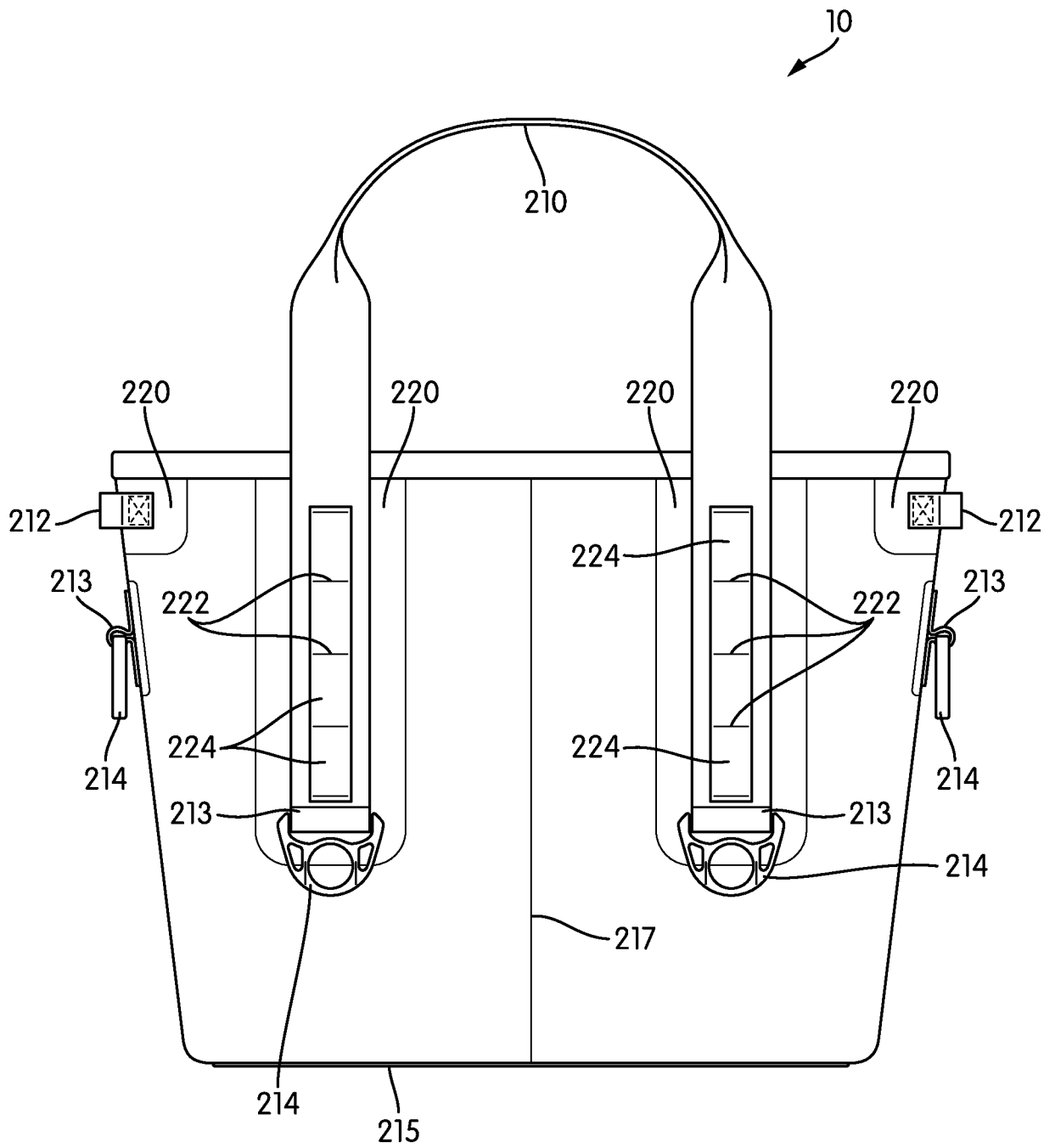

FIG. 2

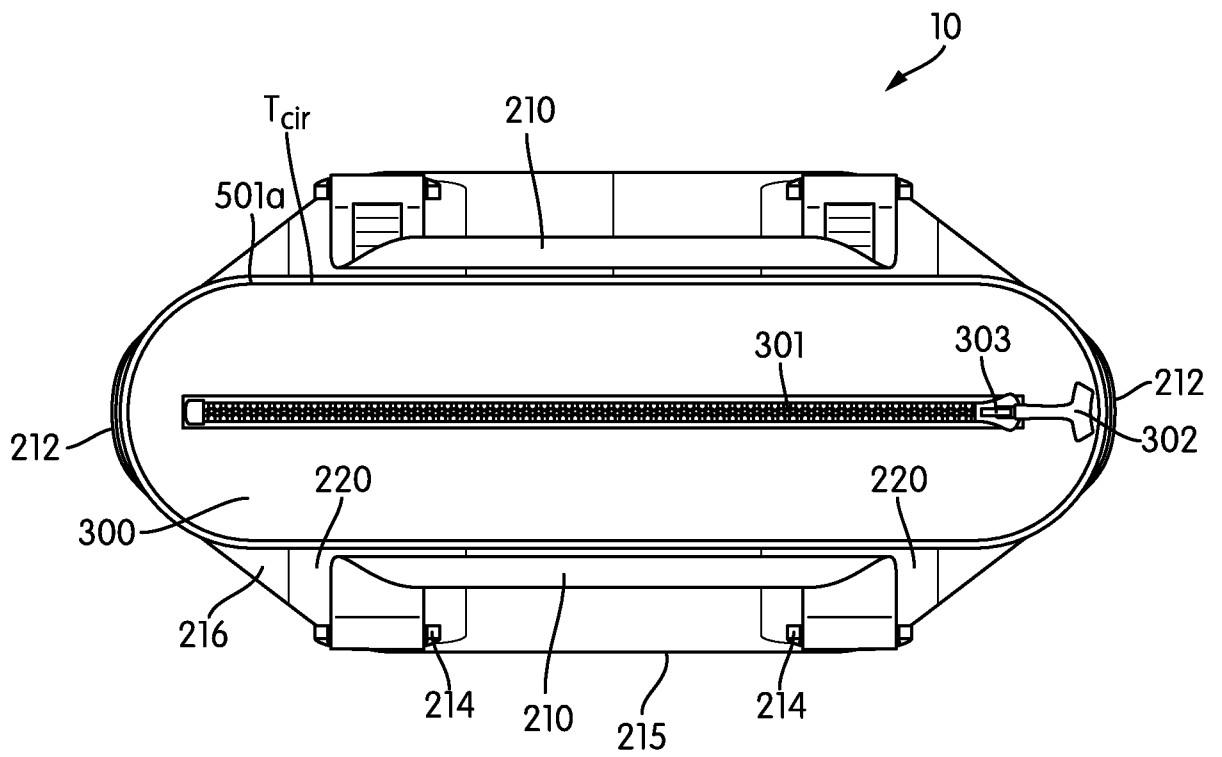

FIG. 3A

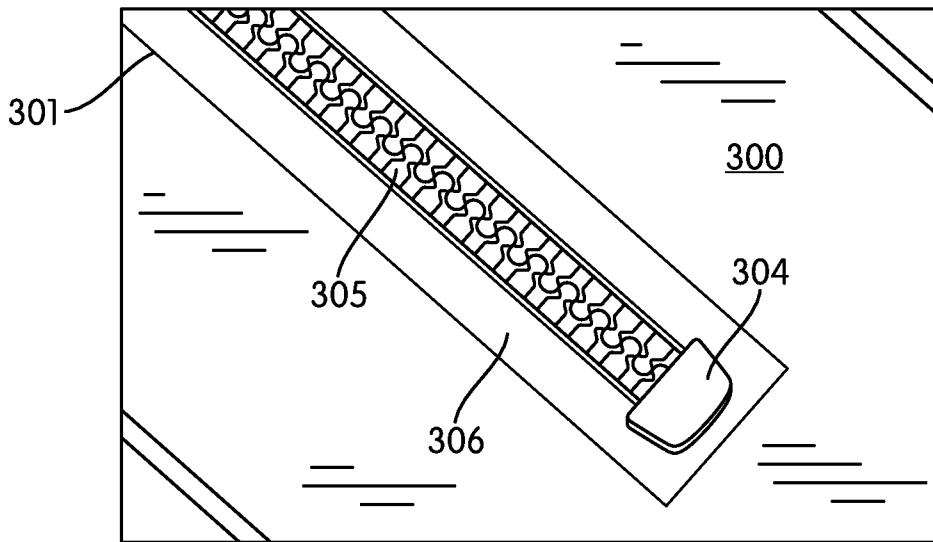

FIG. 3B

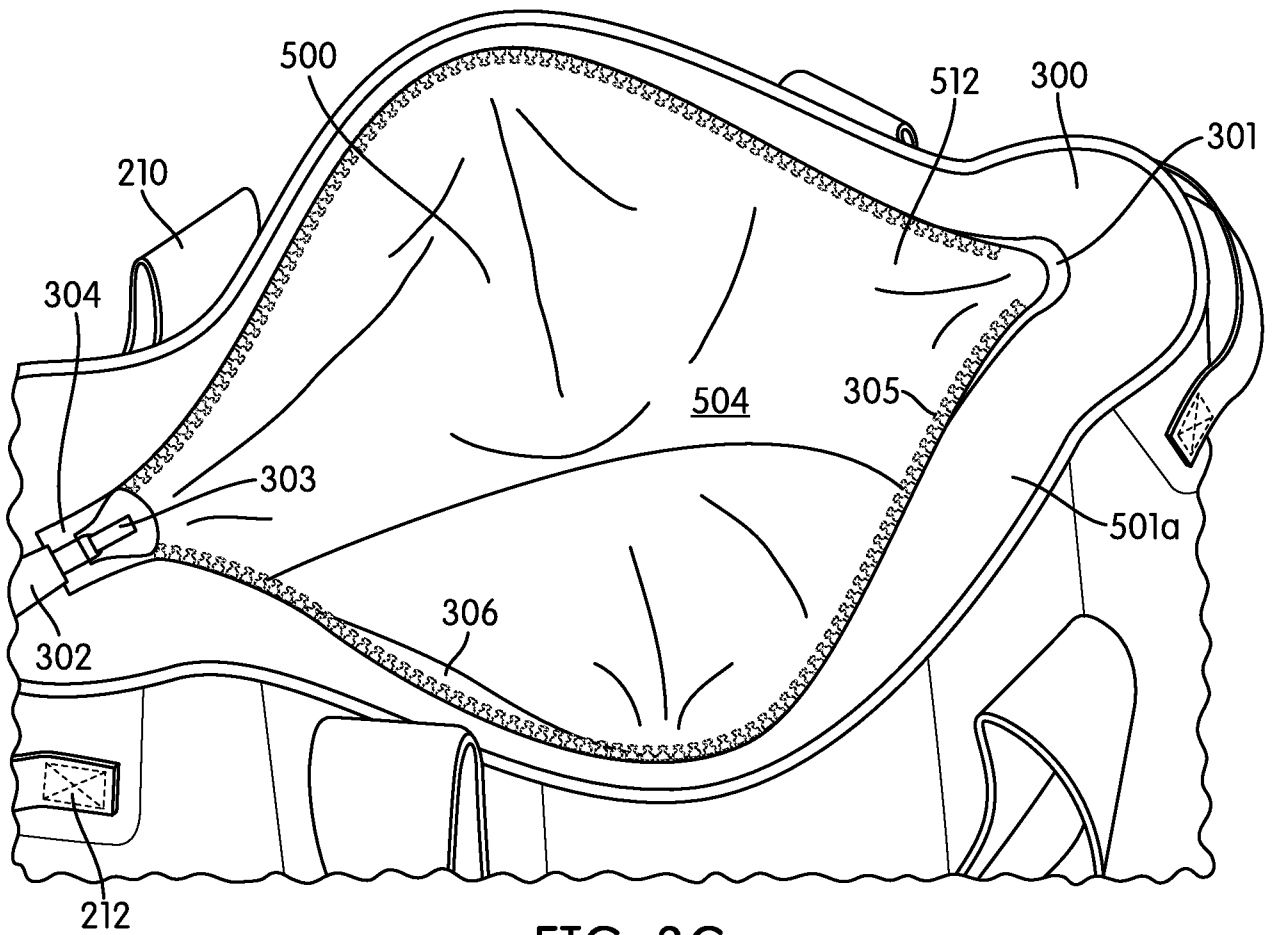

FIG. 3C

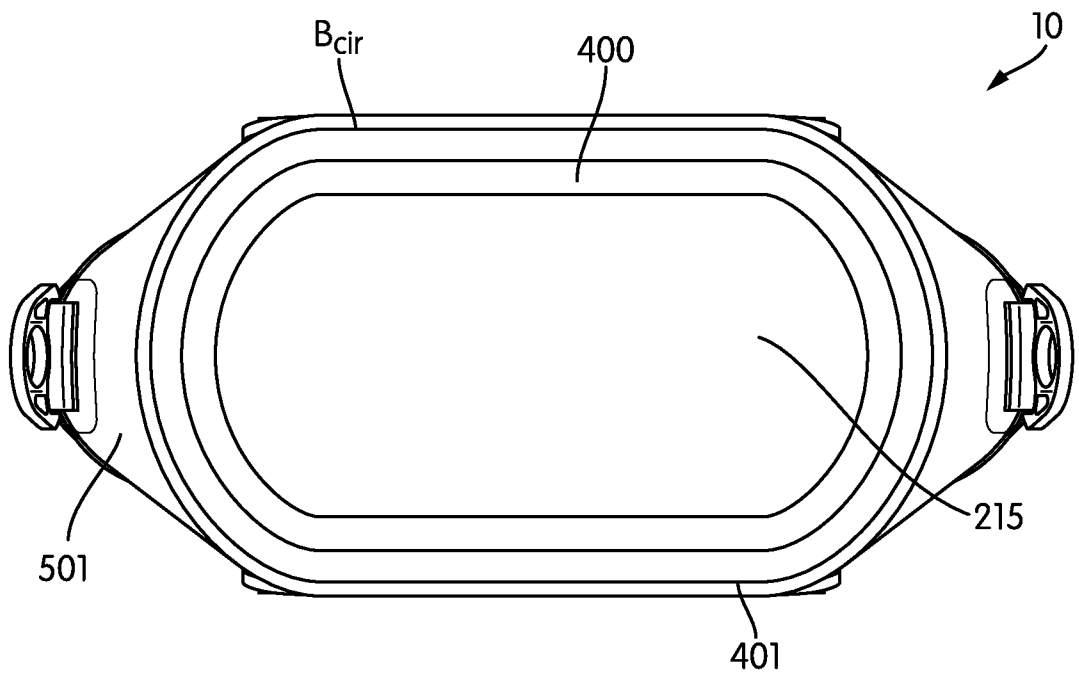

FIG. 4

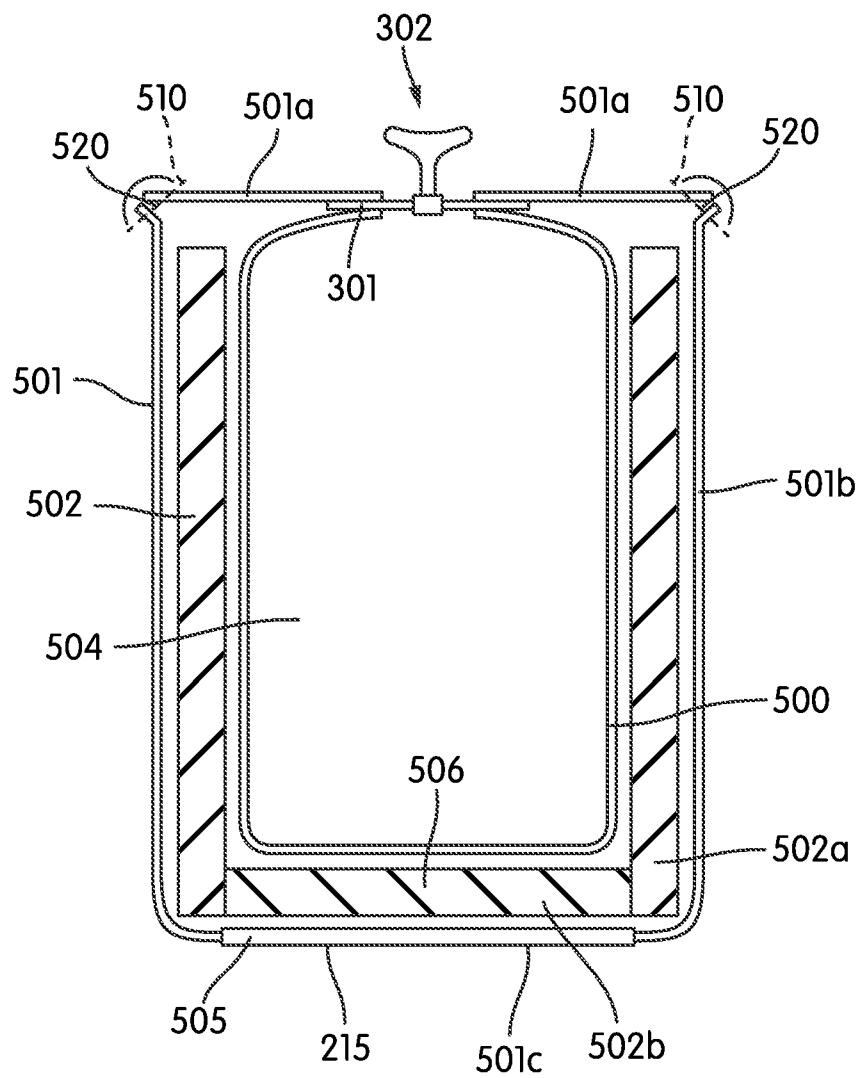

FIG. 5A

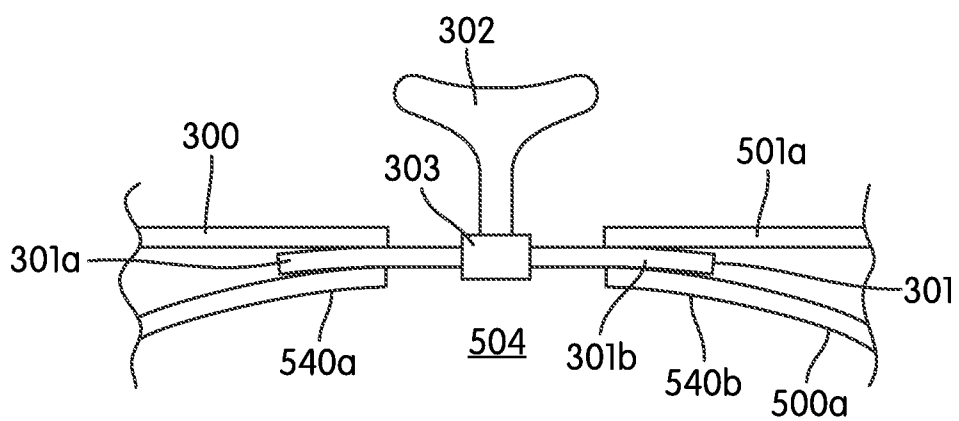

FIG. 5B

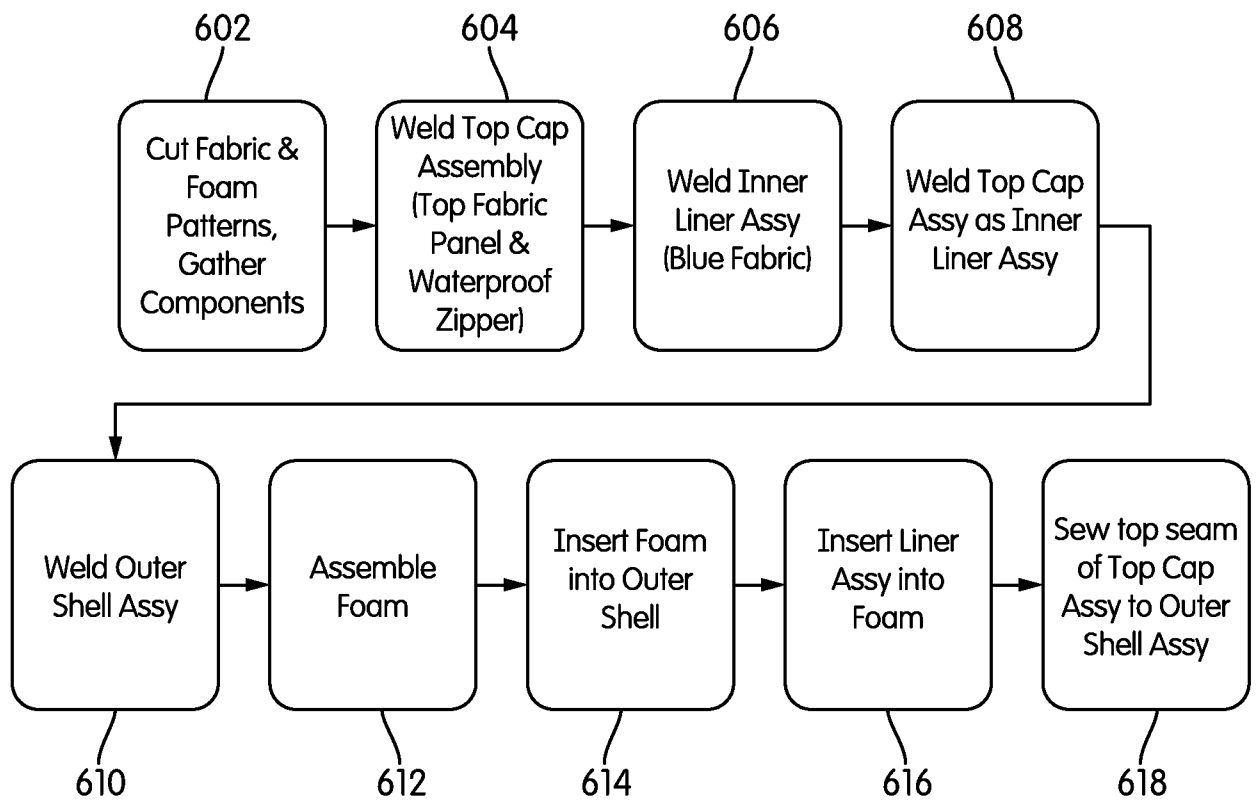

FIG. 6

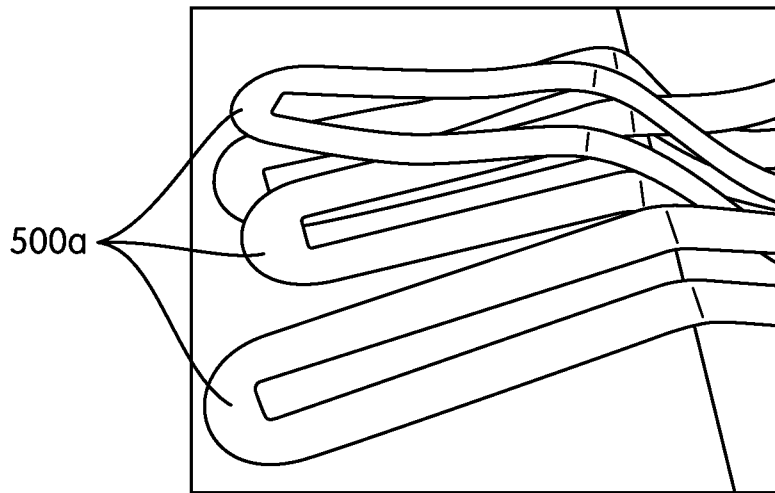

FIG. 7A

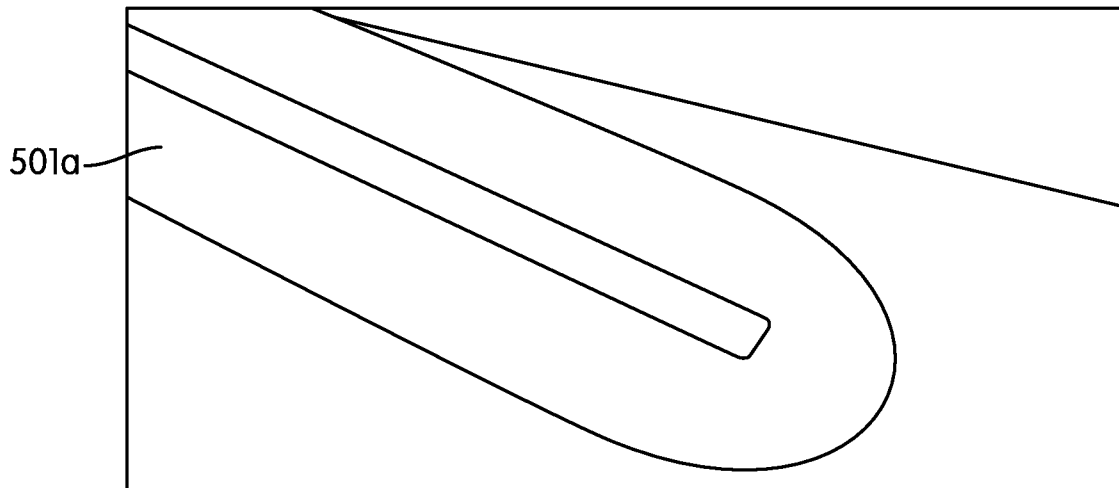

FIG. 7B

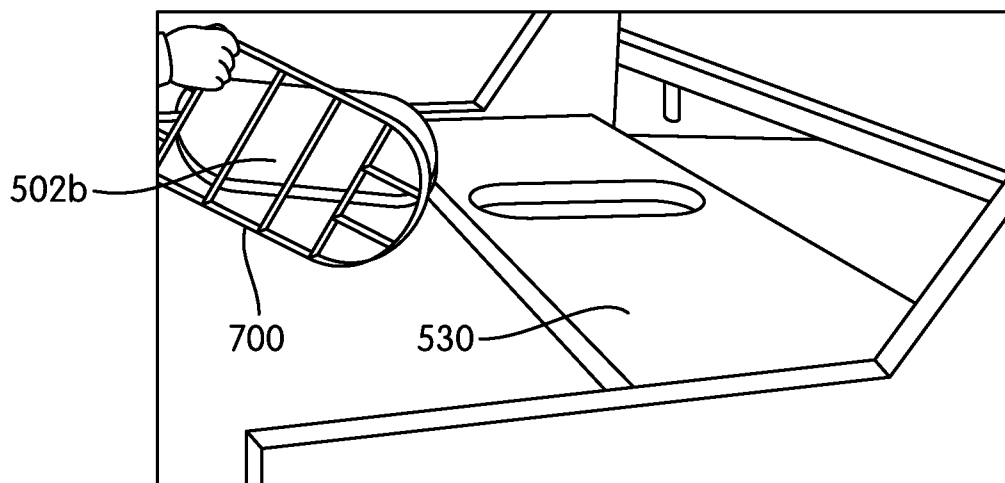

FIG. 7C

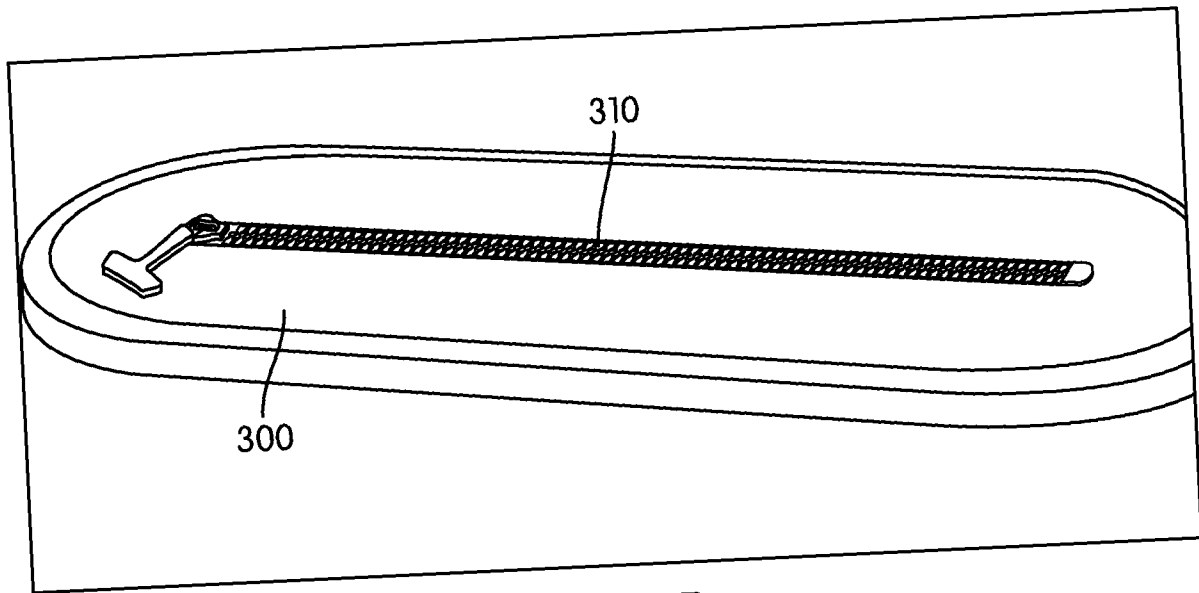

FIG. 7D

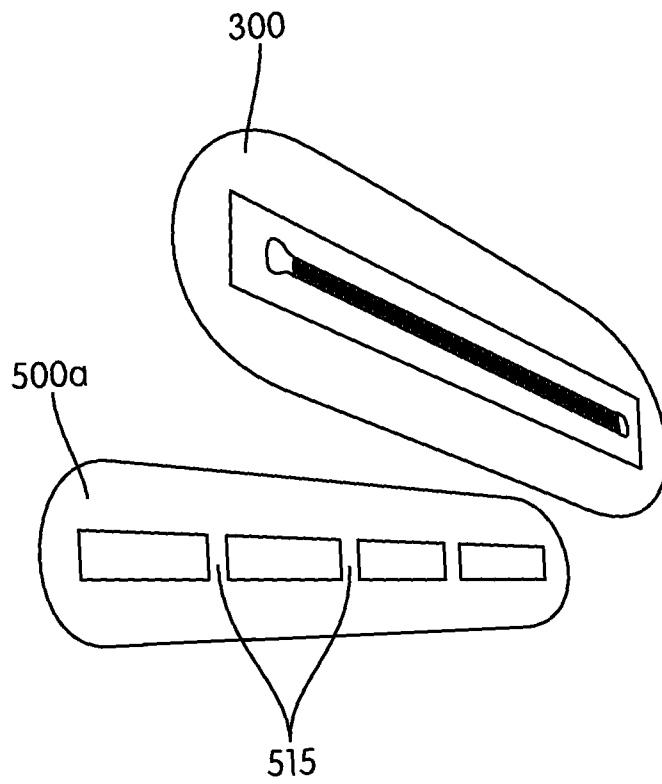

FIG. 7E

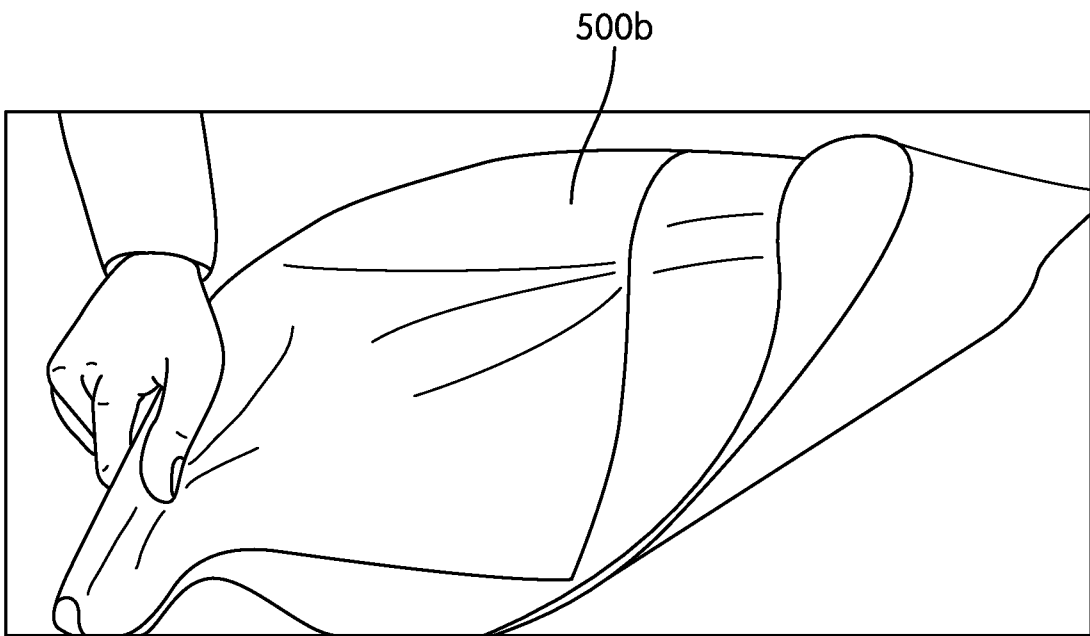

FIG. 7F

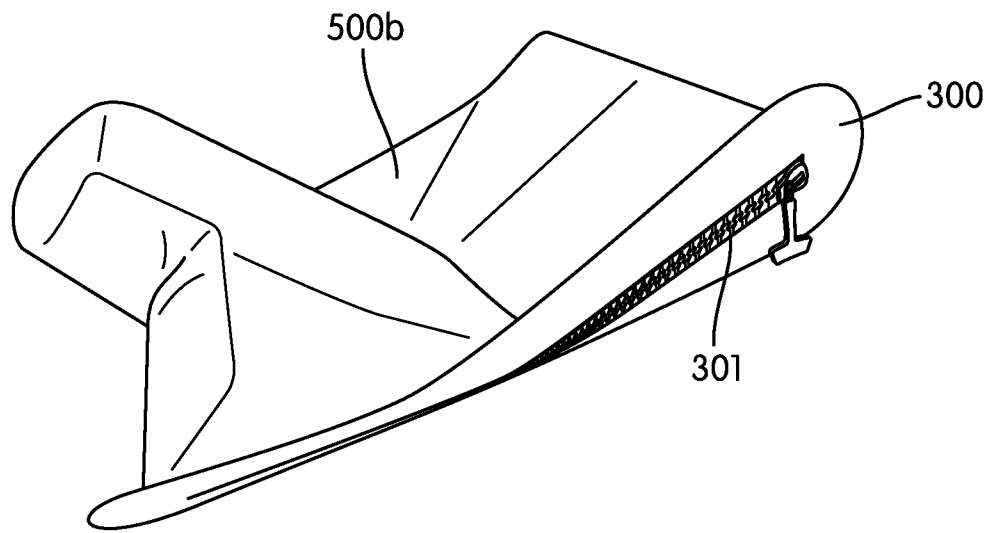

FIG. 7G

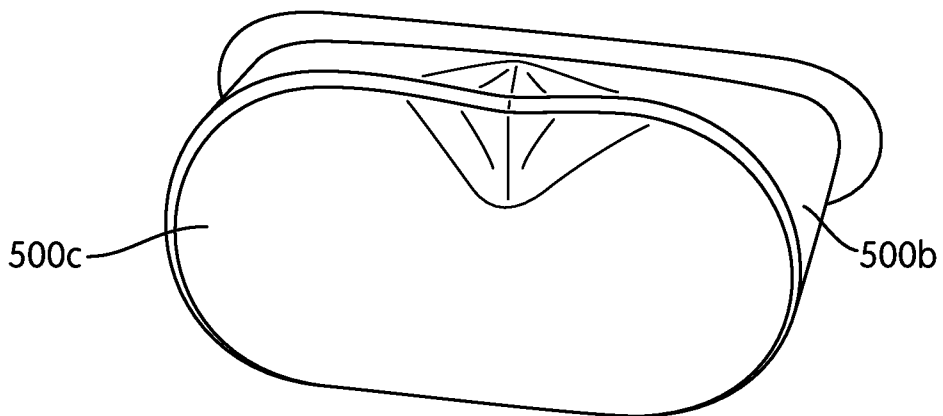

FIG. 7H

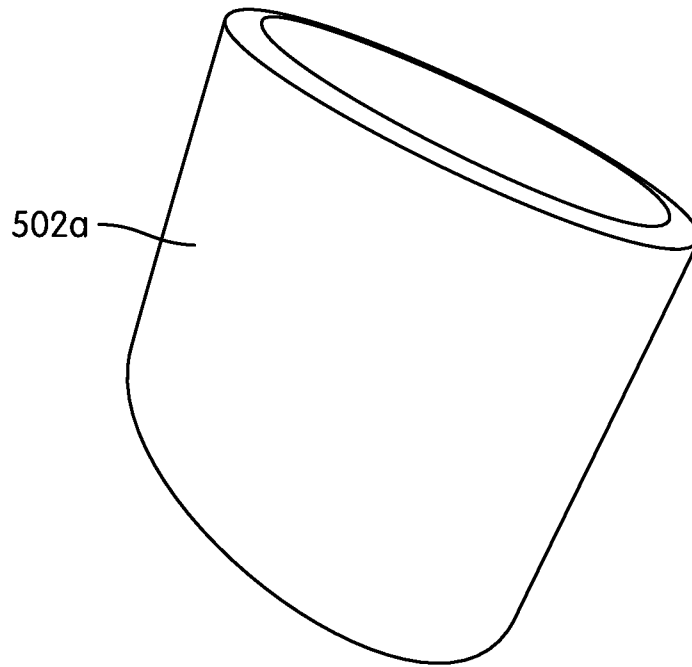

FIG. 7I

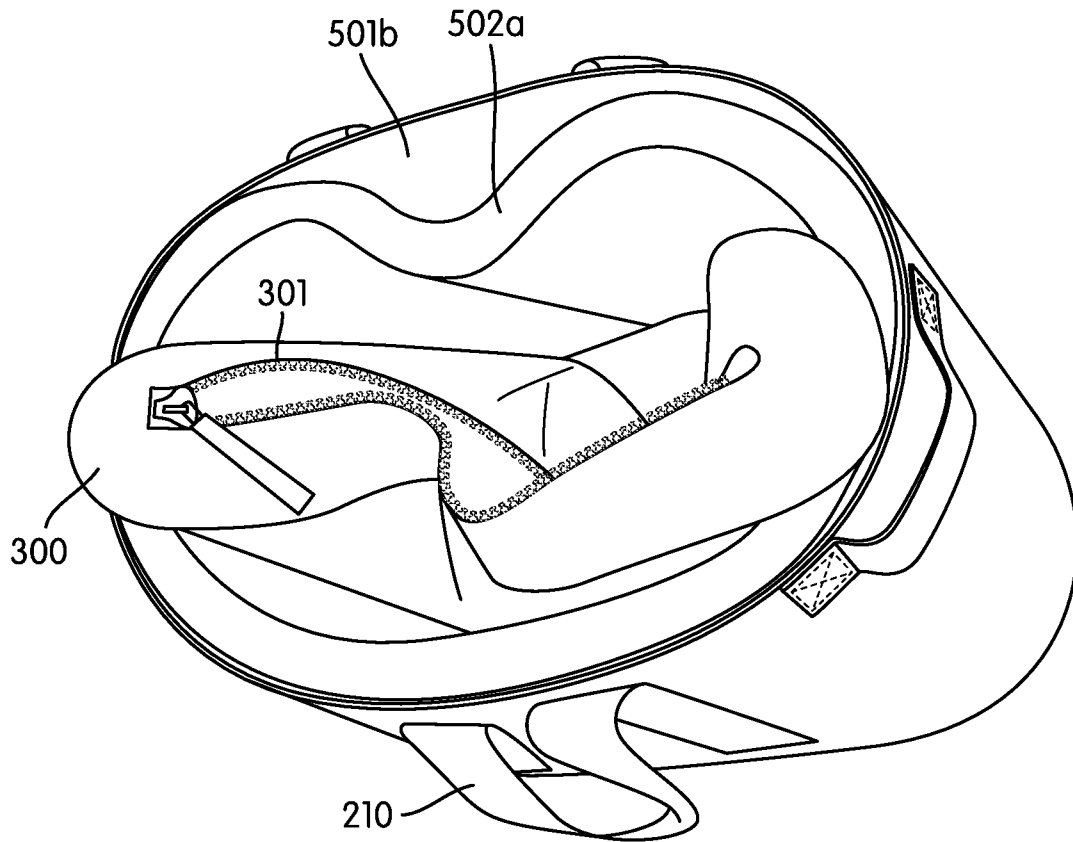

FIG. 7J

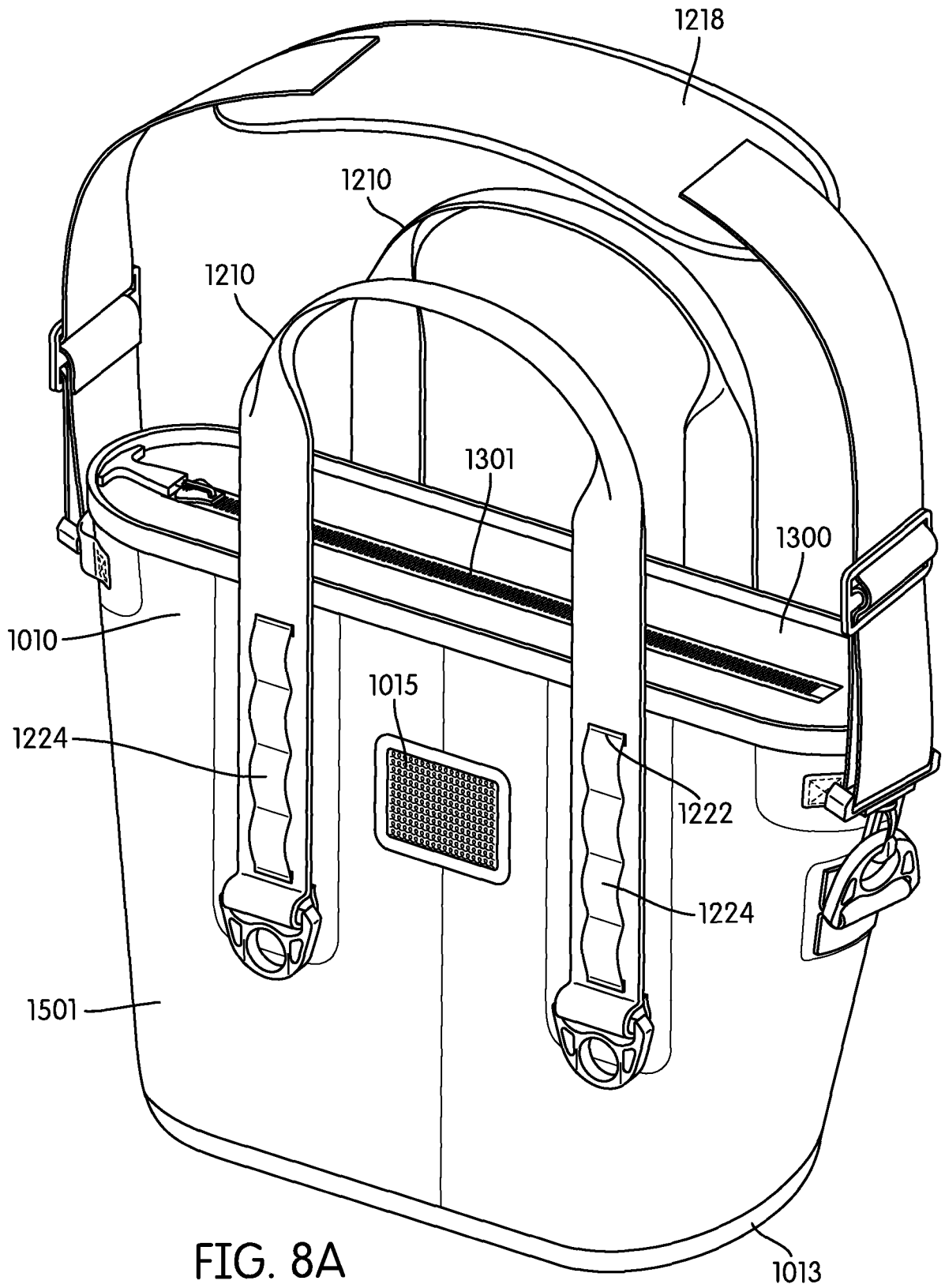
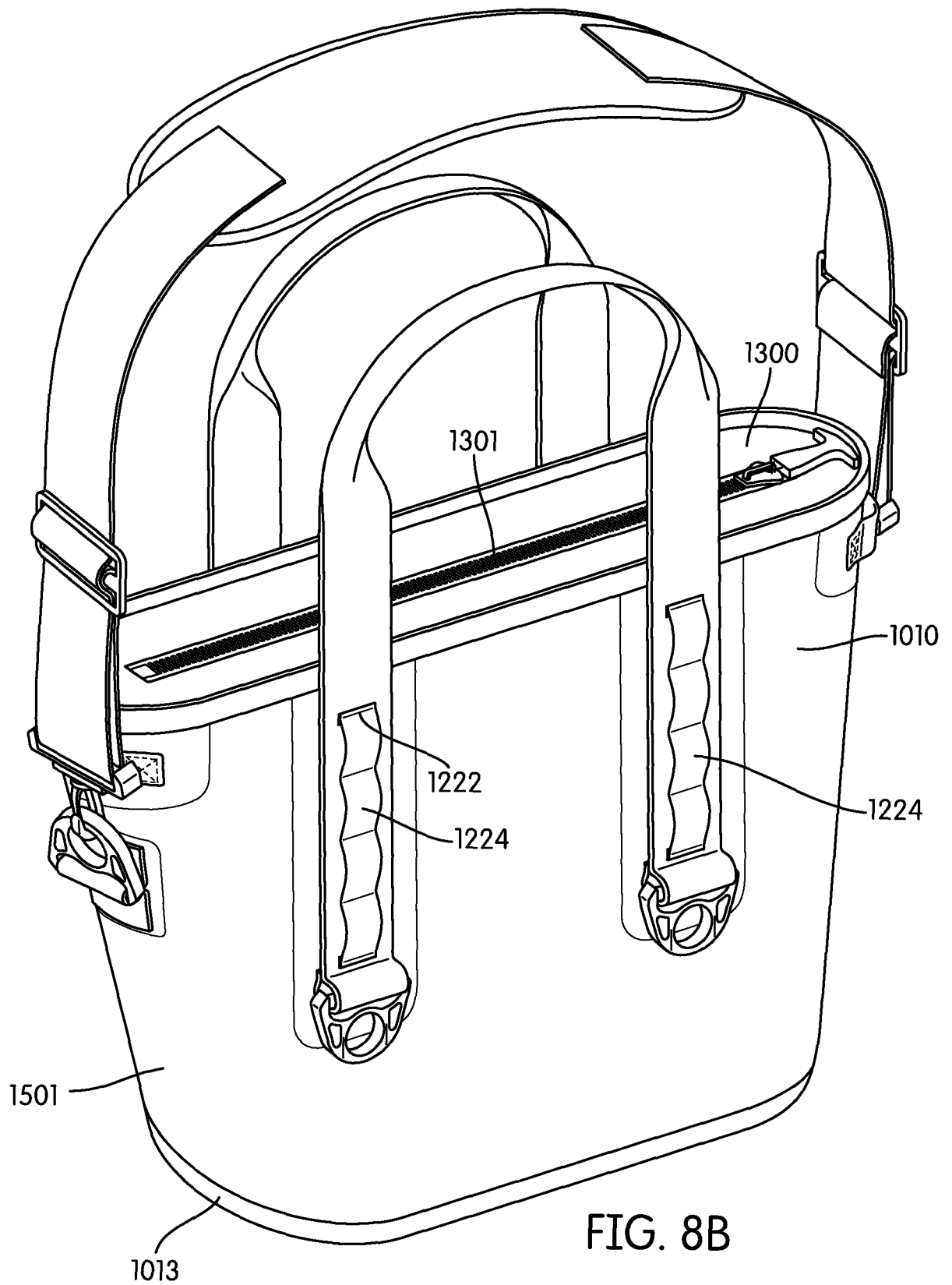

FIG. 8A



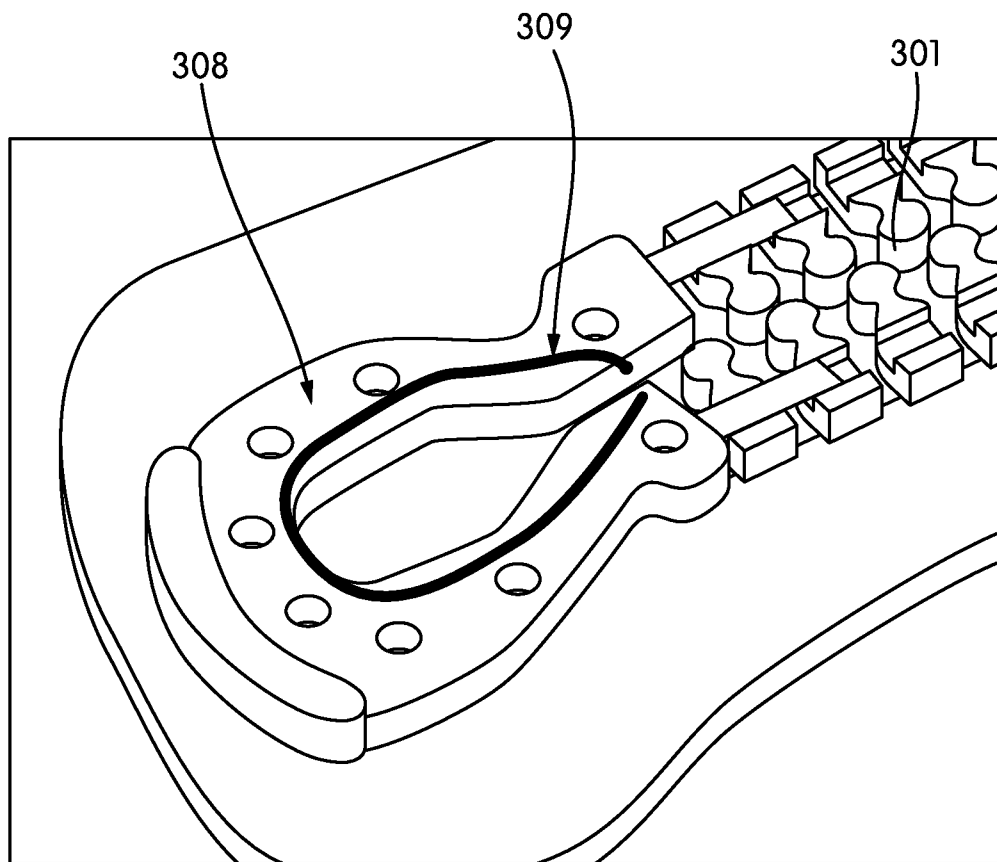

FIG. 9

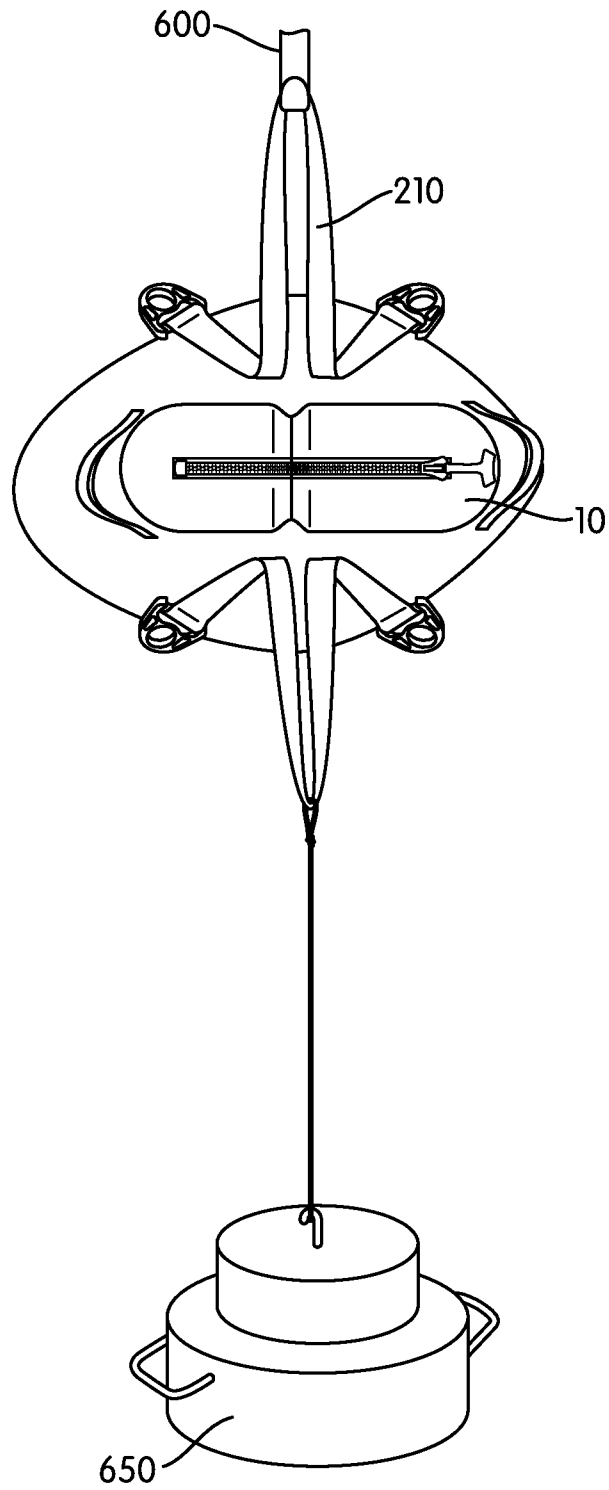

FIG. 10

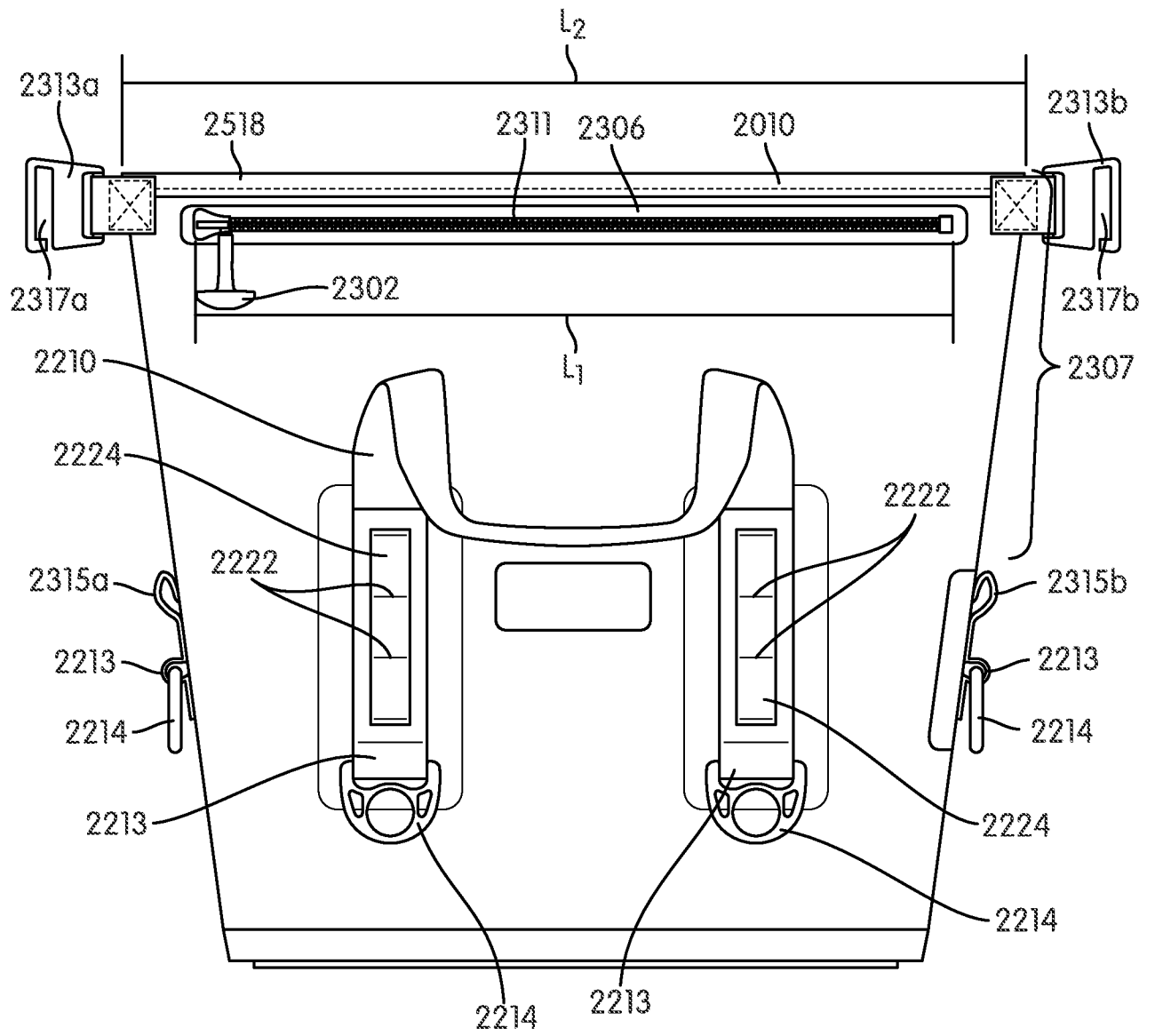

FIG. 11

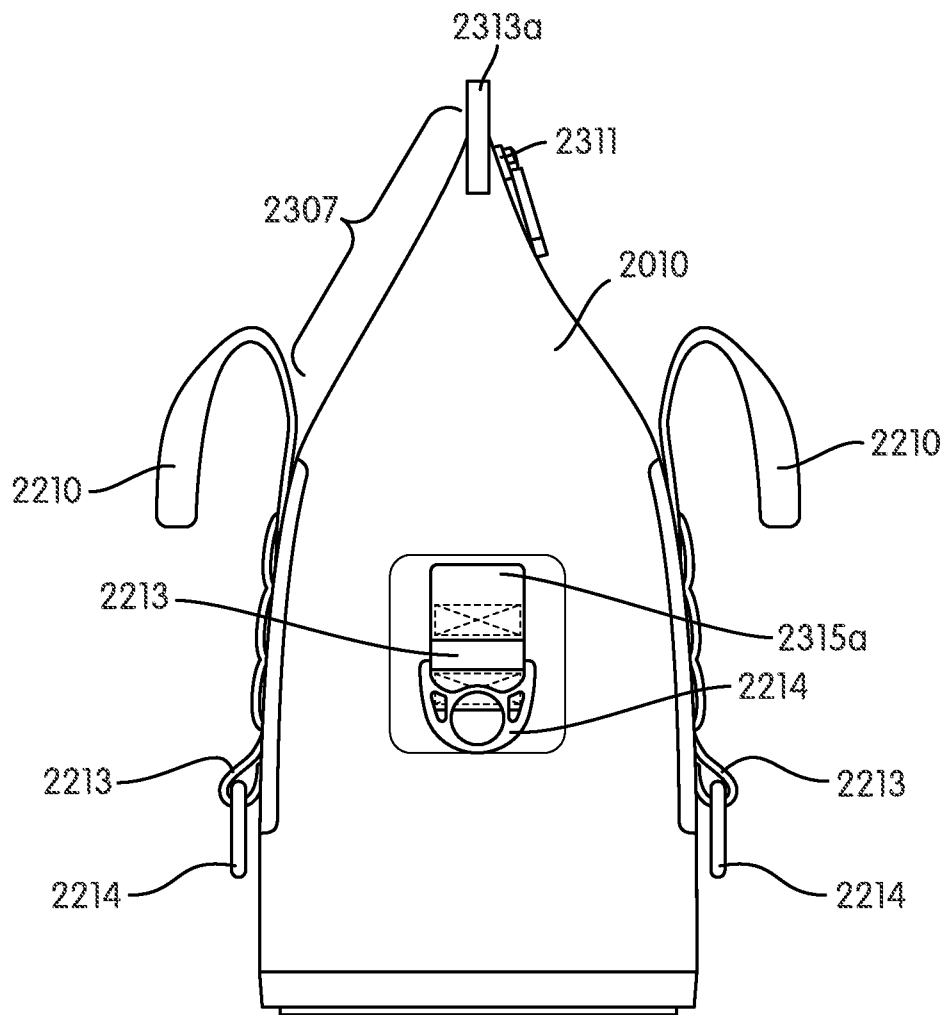

FIG. 12

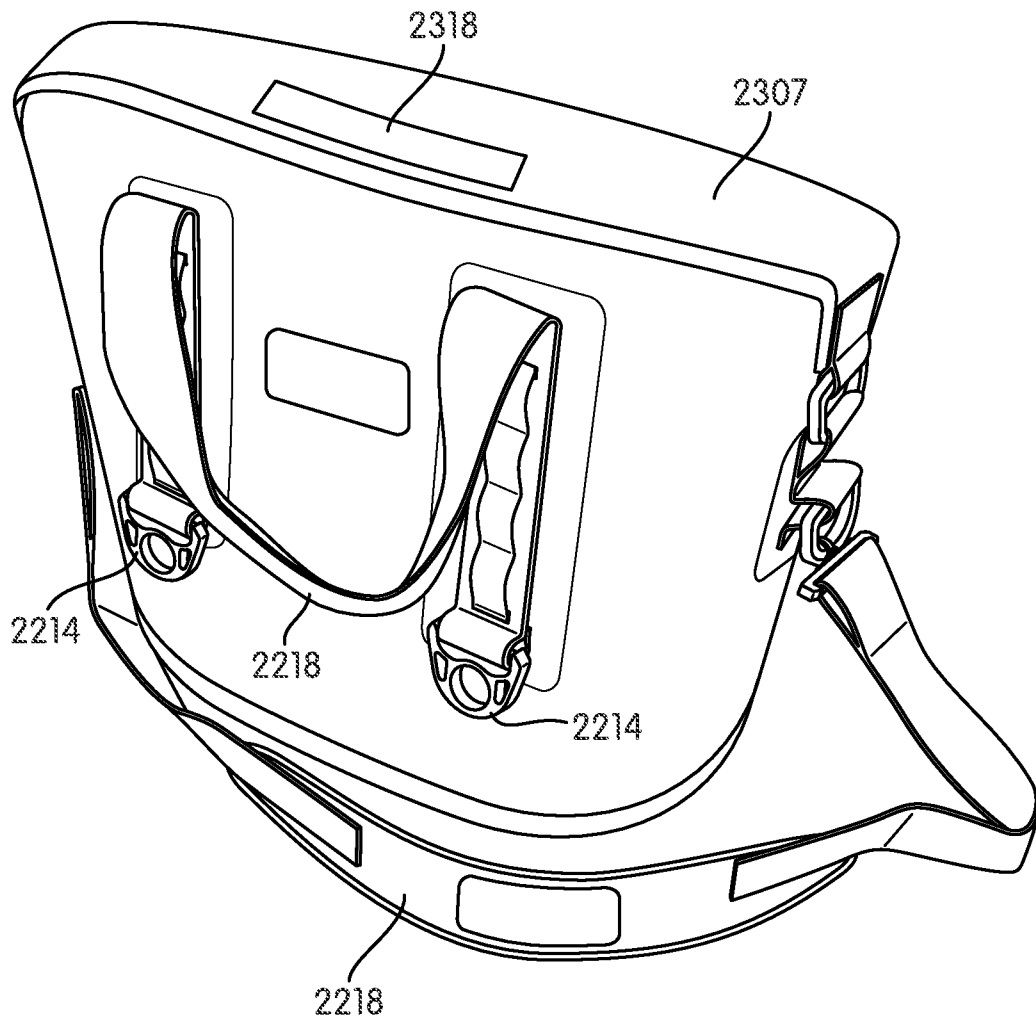

FIG. 13

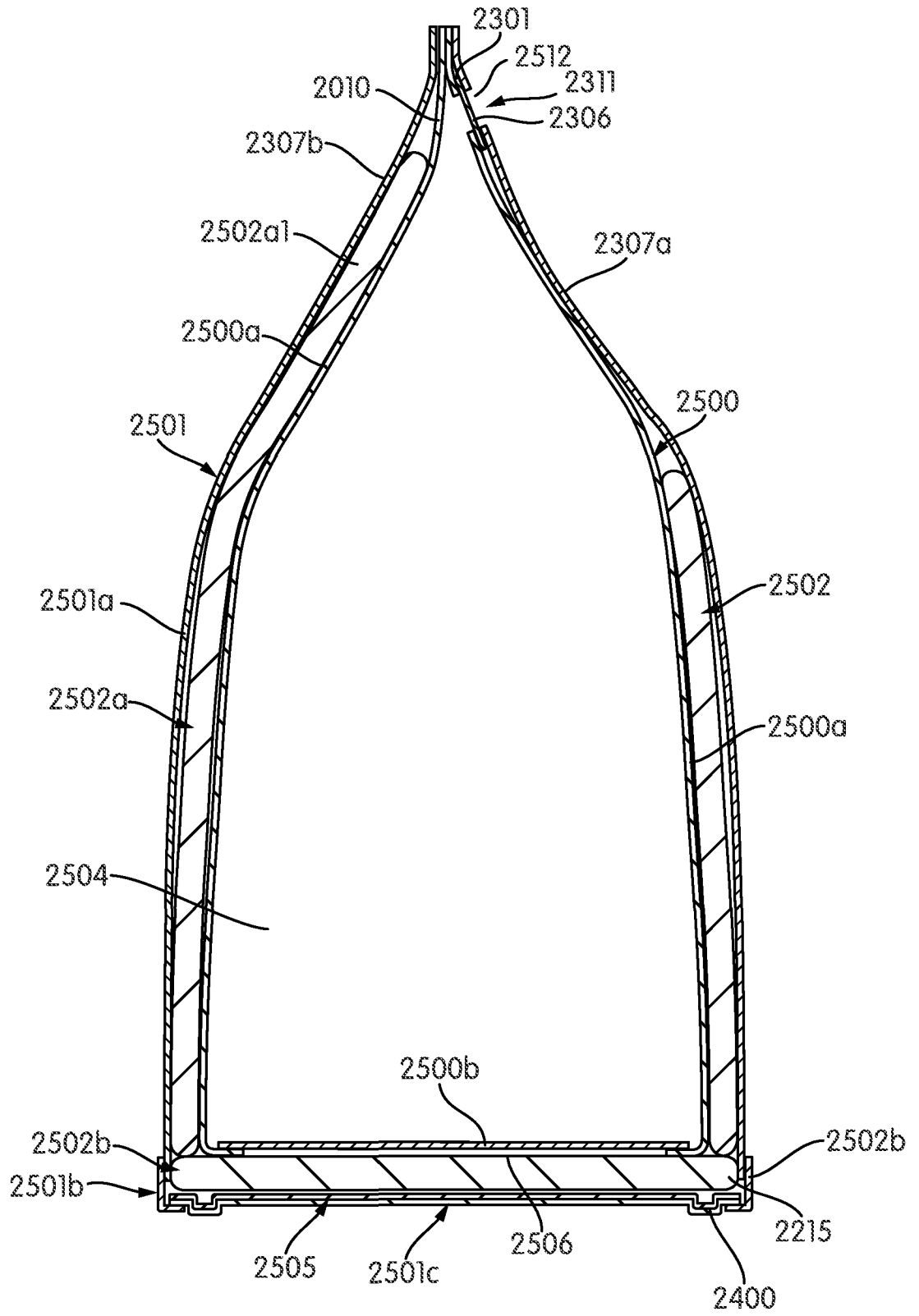

FIG. 14A

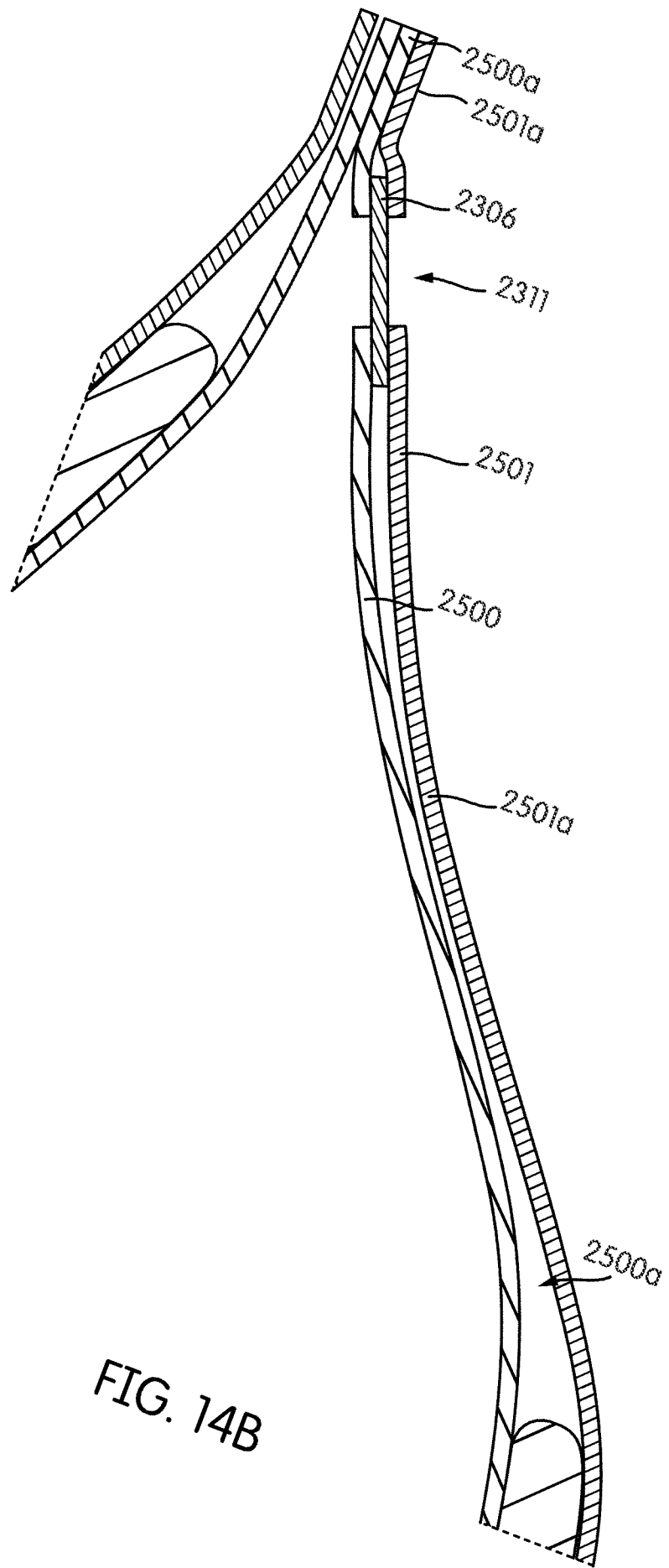

FIG. 14B

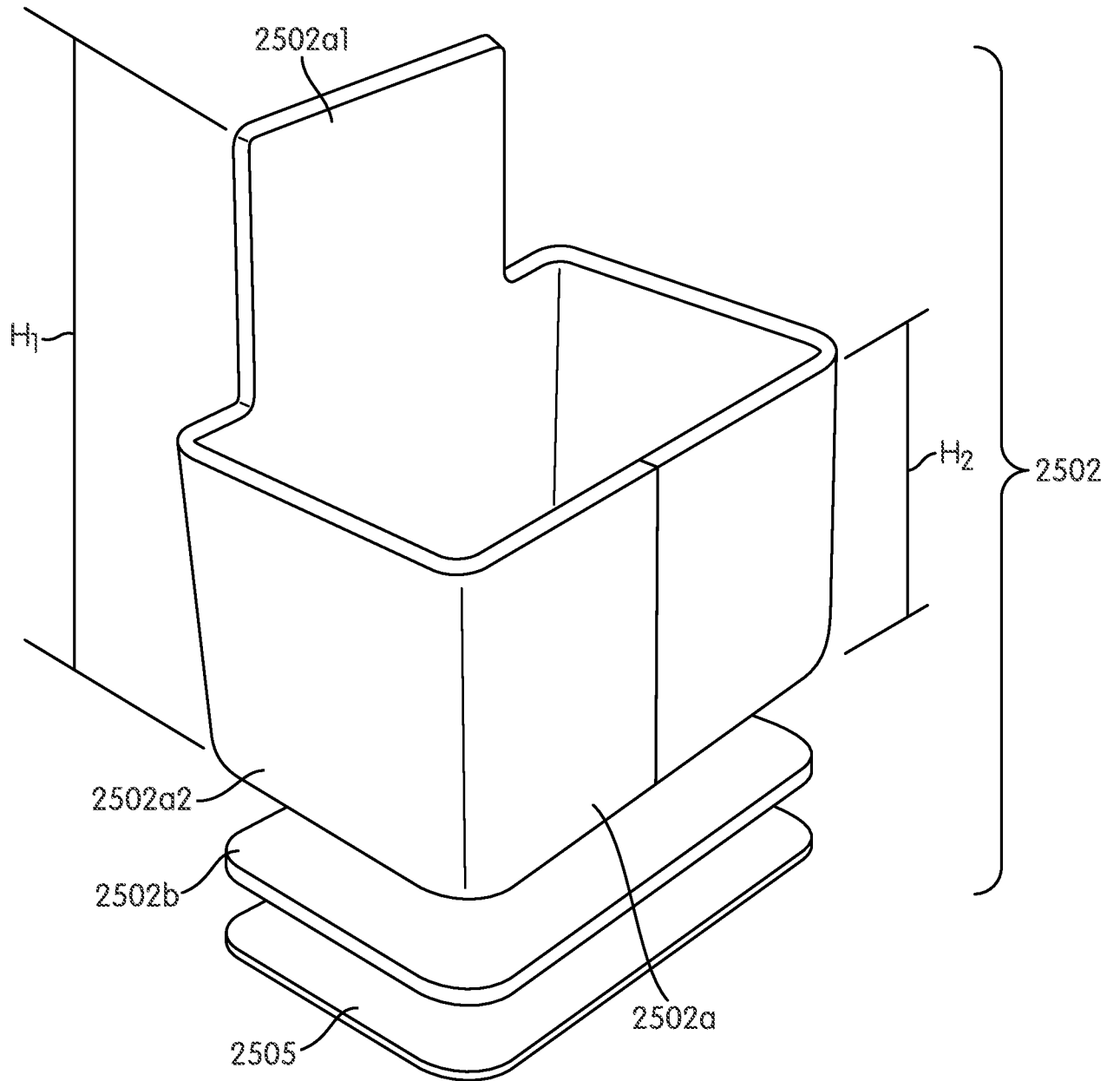

FIG. 15

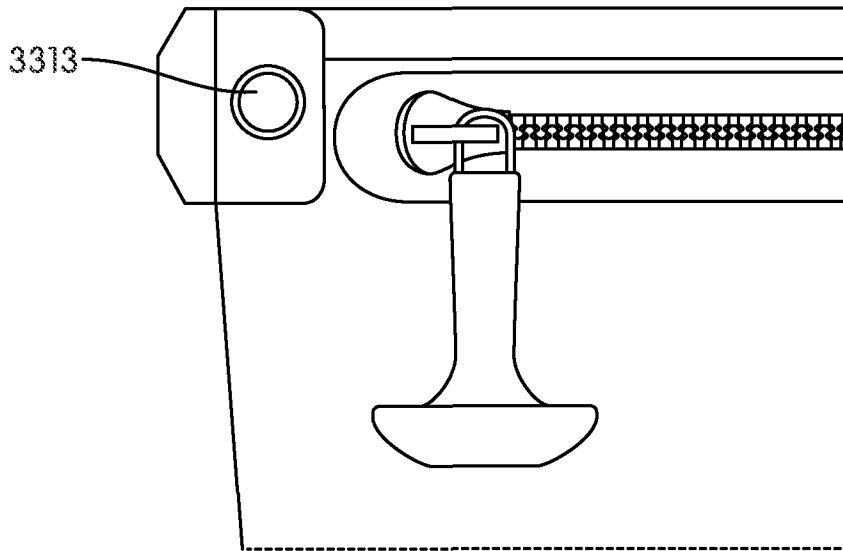

FIG. 16A

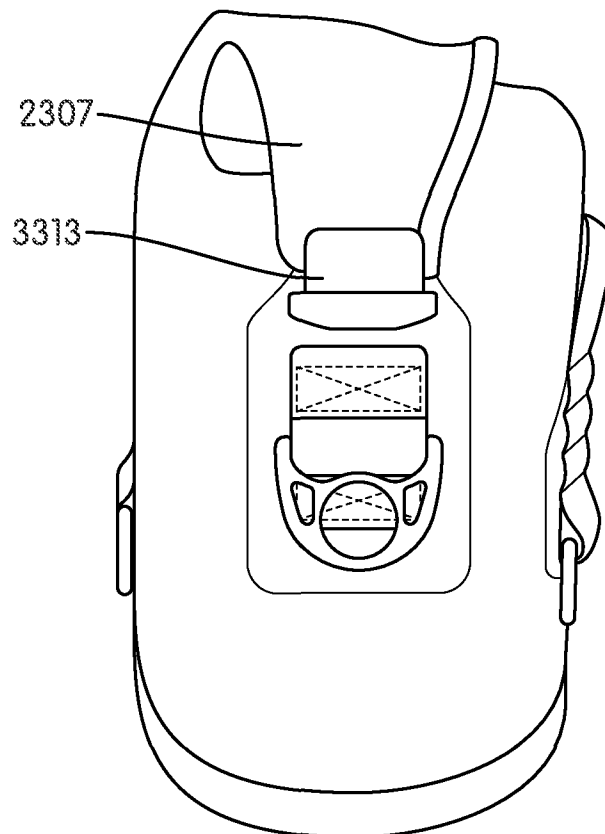

FIG. 16B

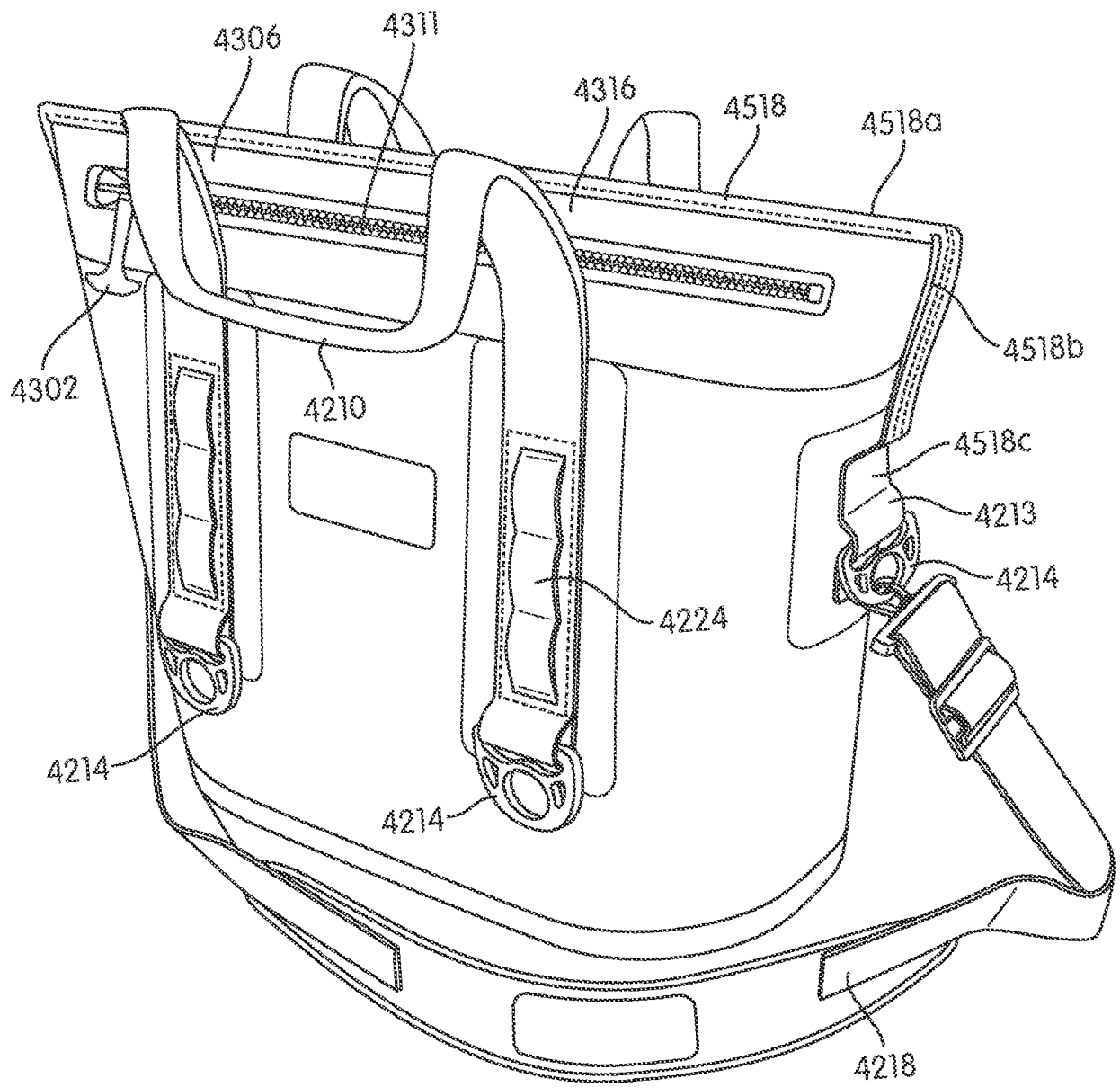

FIG. 17

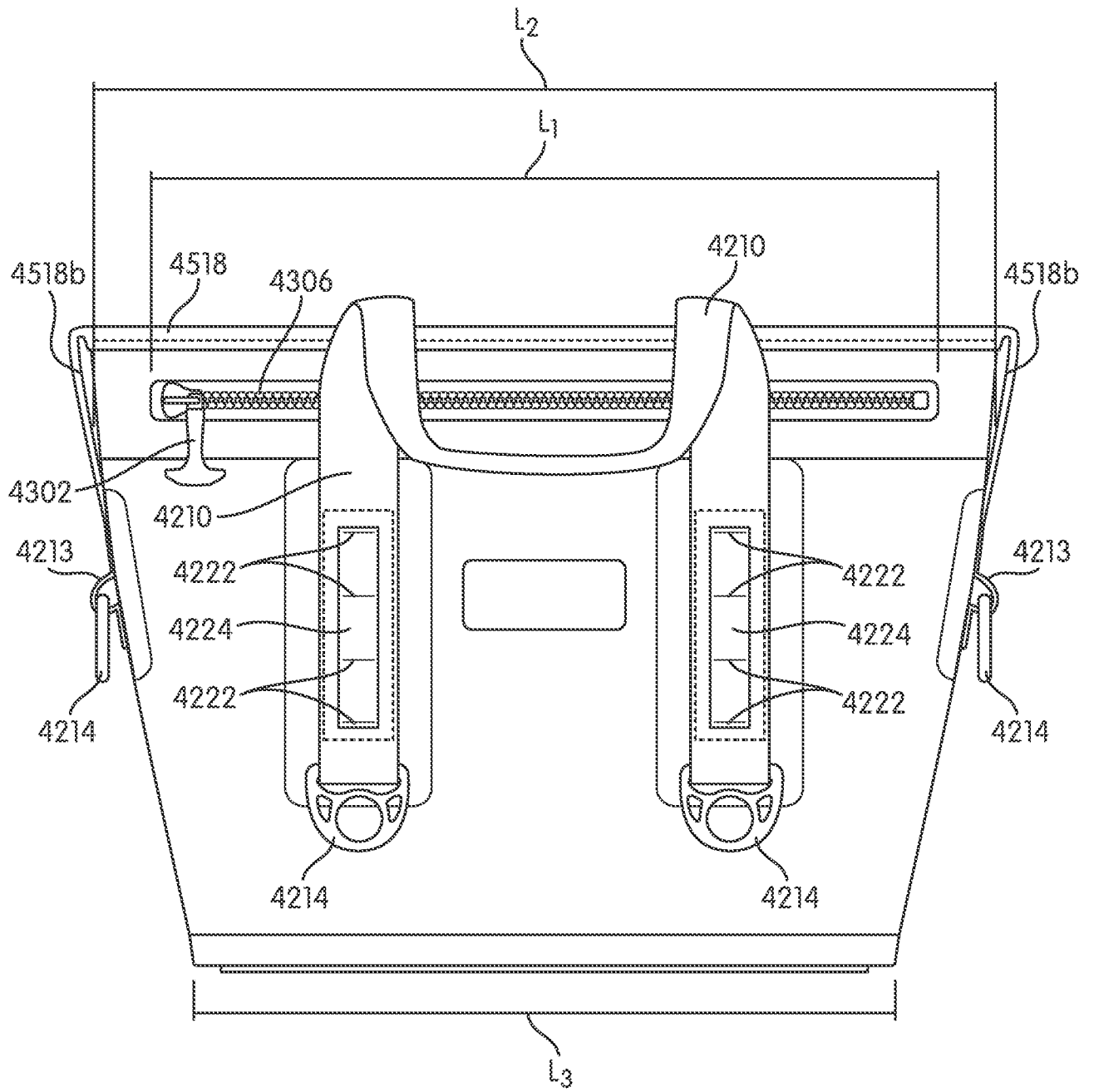

FIG. 18

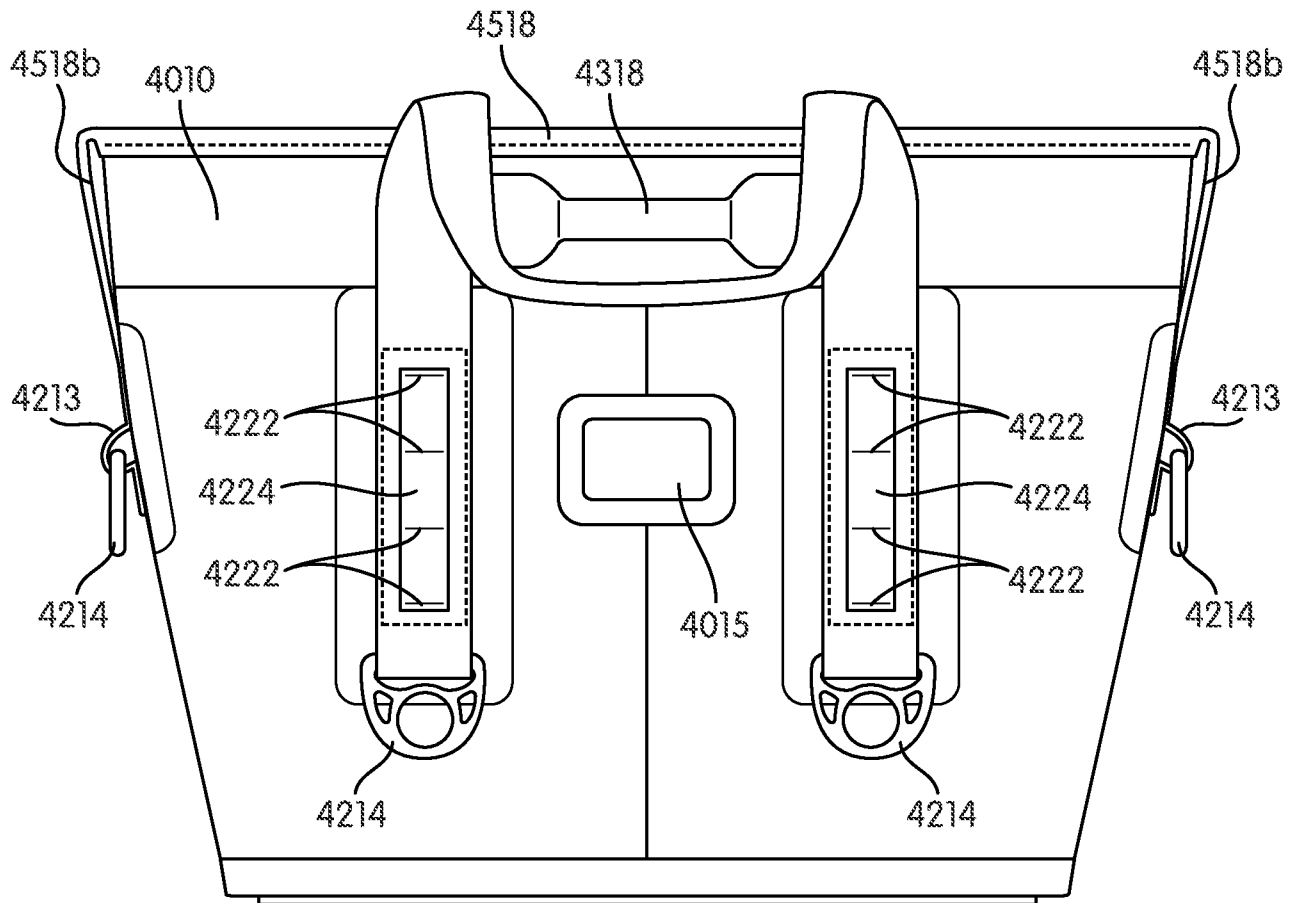

FIG. 19

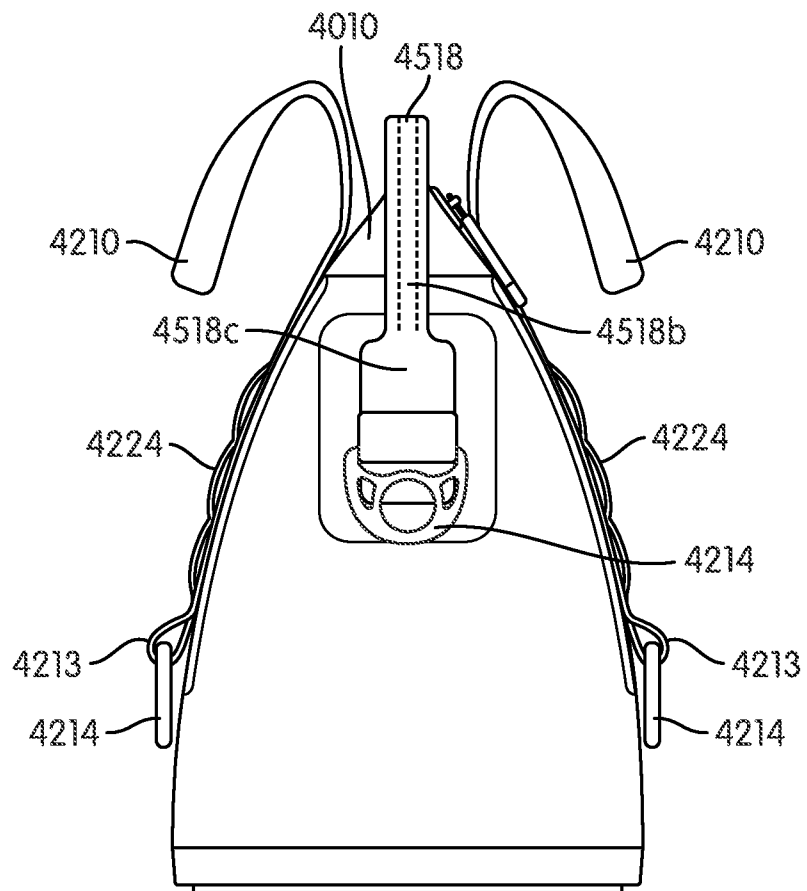

FIG. 20

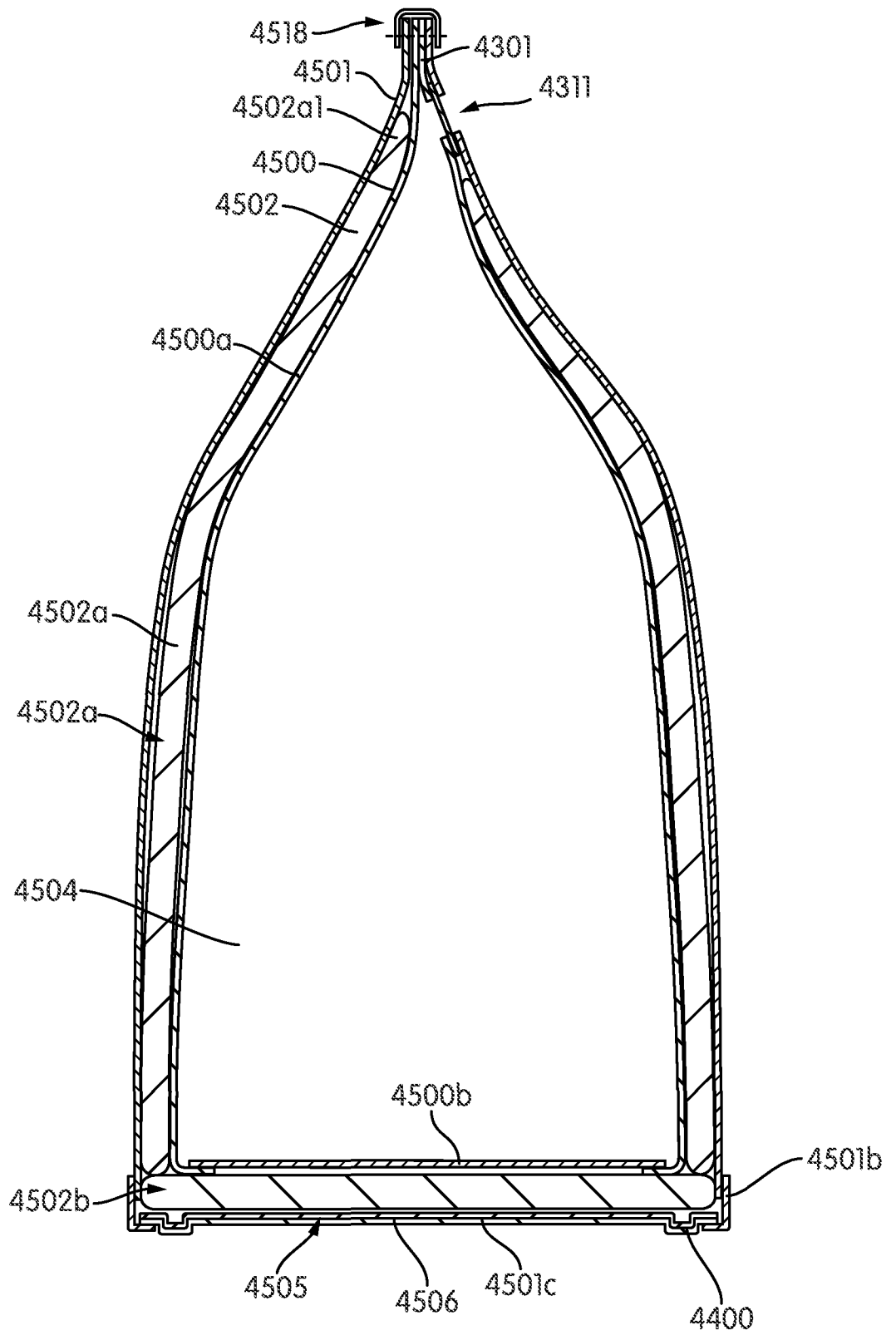

FIG. 21

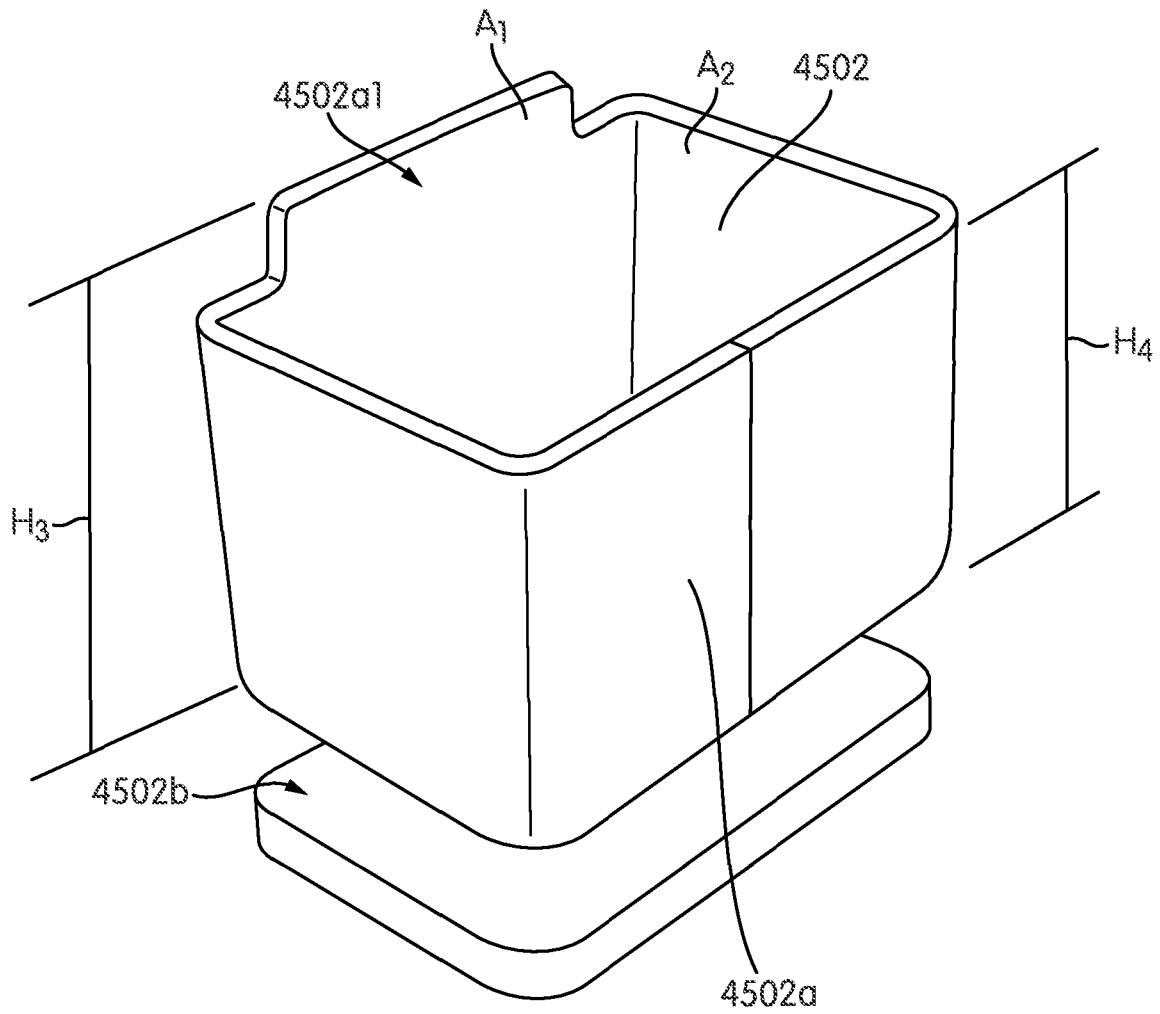

FIG. 22

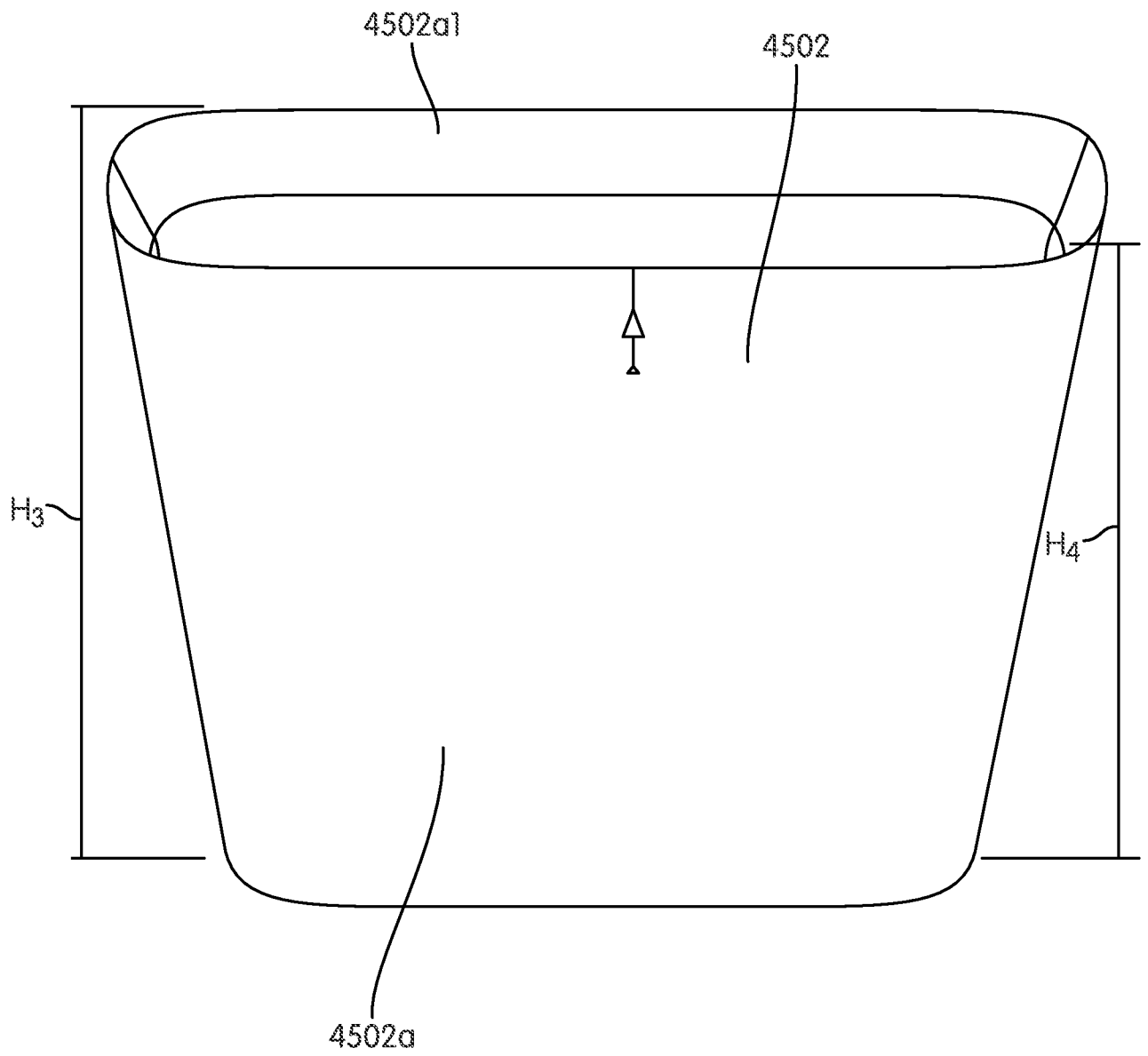

FIG. 22A

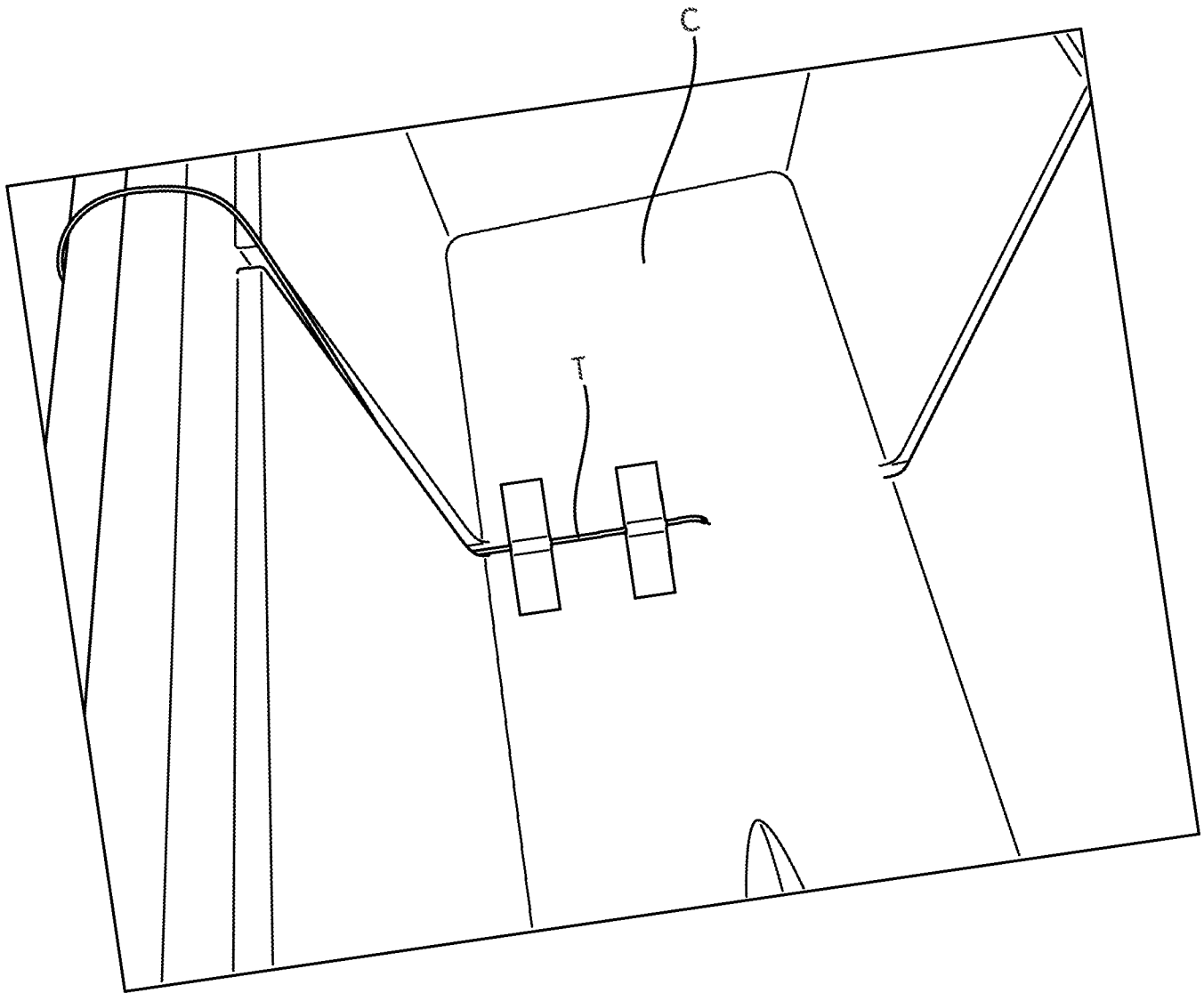

FIG. 23