



US 20110080344A1

(19) **United States**

(12) **Patent Application Publication**  
**Dura et al.**

(10) **Pub. No.: US 2011/0080344 A1**

(43) **Pub. Date: Apr. 7, 2011**

(54) **BLENDING TOUCH DATA STREAMS THAT INCLUDE TOUCH INPUT DATA**

**Publication Classification**

(75) Inventors: **Daniel Adam Dura**, Garland, TX (US); **Mark Frederick Miller**, Wylie, TX (US)

(51) **Int. Cl.**  
**G06F 3/033** (2006.01)  
**G06F 3/02** (2006.01)  
**G06F 3/041** (2006.01)

(73) Assignee: **Dedo Interactive Inc.**, Plano, TX (US)

(52) **U.S. Cl.** ..... **345/163; 345/168; 345/173**

(21) Appl. No.: **12/893,427**

(57) **ABSTRACT**

(22) Filed: **Sep. 29, 2010**

A system includes multiple touch input devices. Each of the touch input devices generates a set of touch data. A blending component receives the sets of touch data and generates a corresponding combined set of touch data that is outputted to a touch input application. In one embodiment, at least one of the multiple touch input devices is a multitouch input device that supports multiple simultaneous touch inputs.

**Related U.S. Application Data**

(60) Provisional application No. 61/247,964, filed on Oct. 2, 2009.

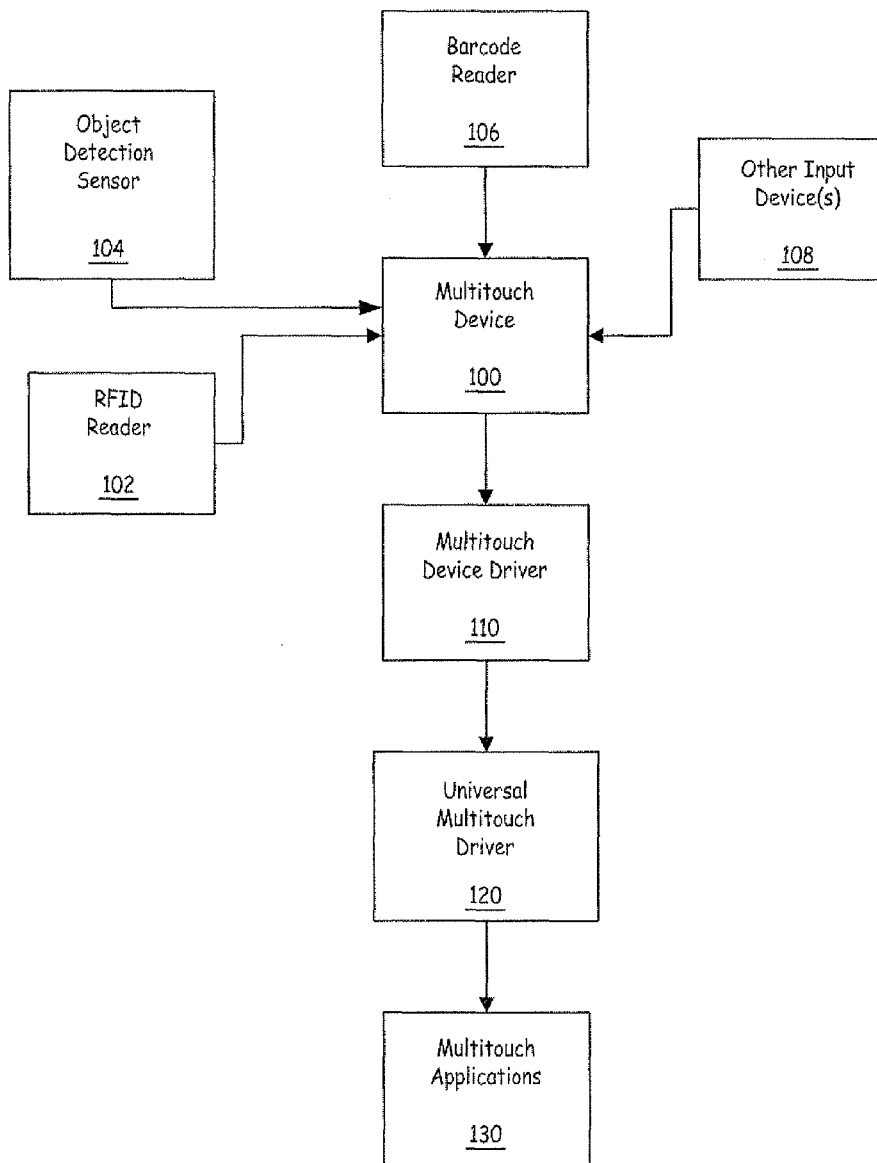

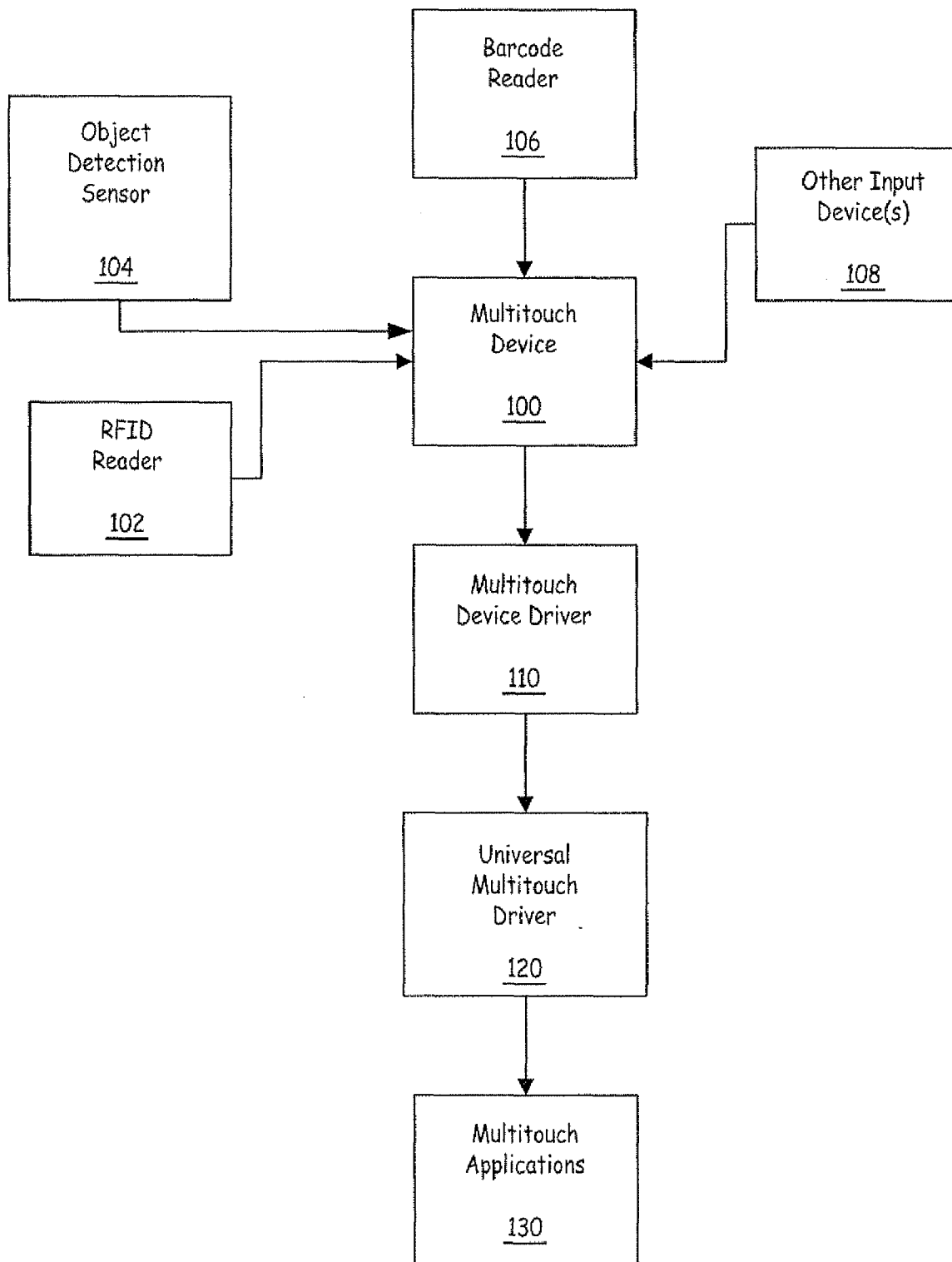

FIG. 1

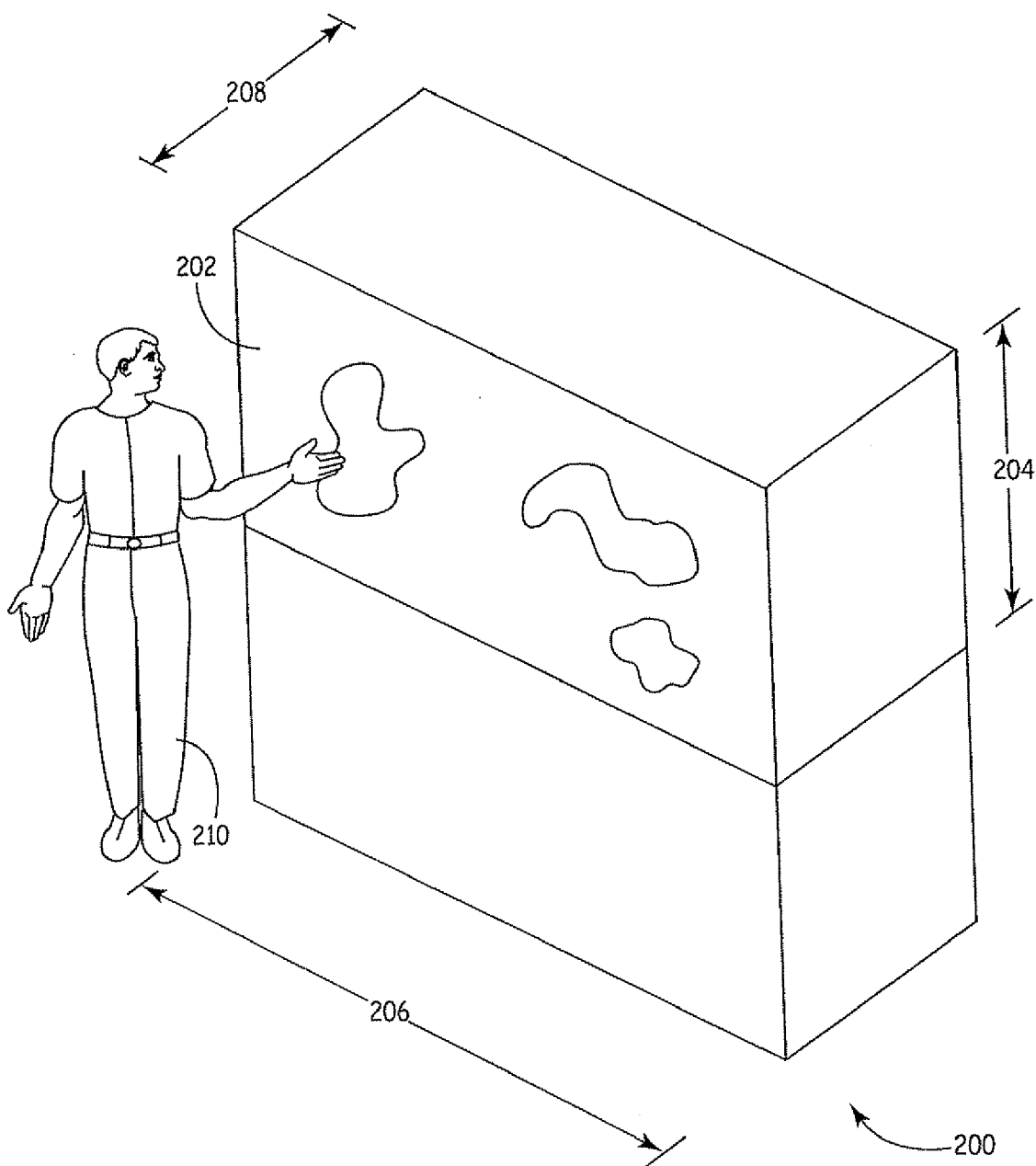

FIG. 2

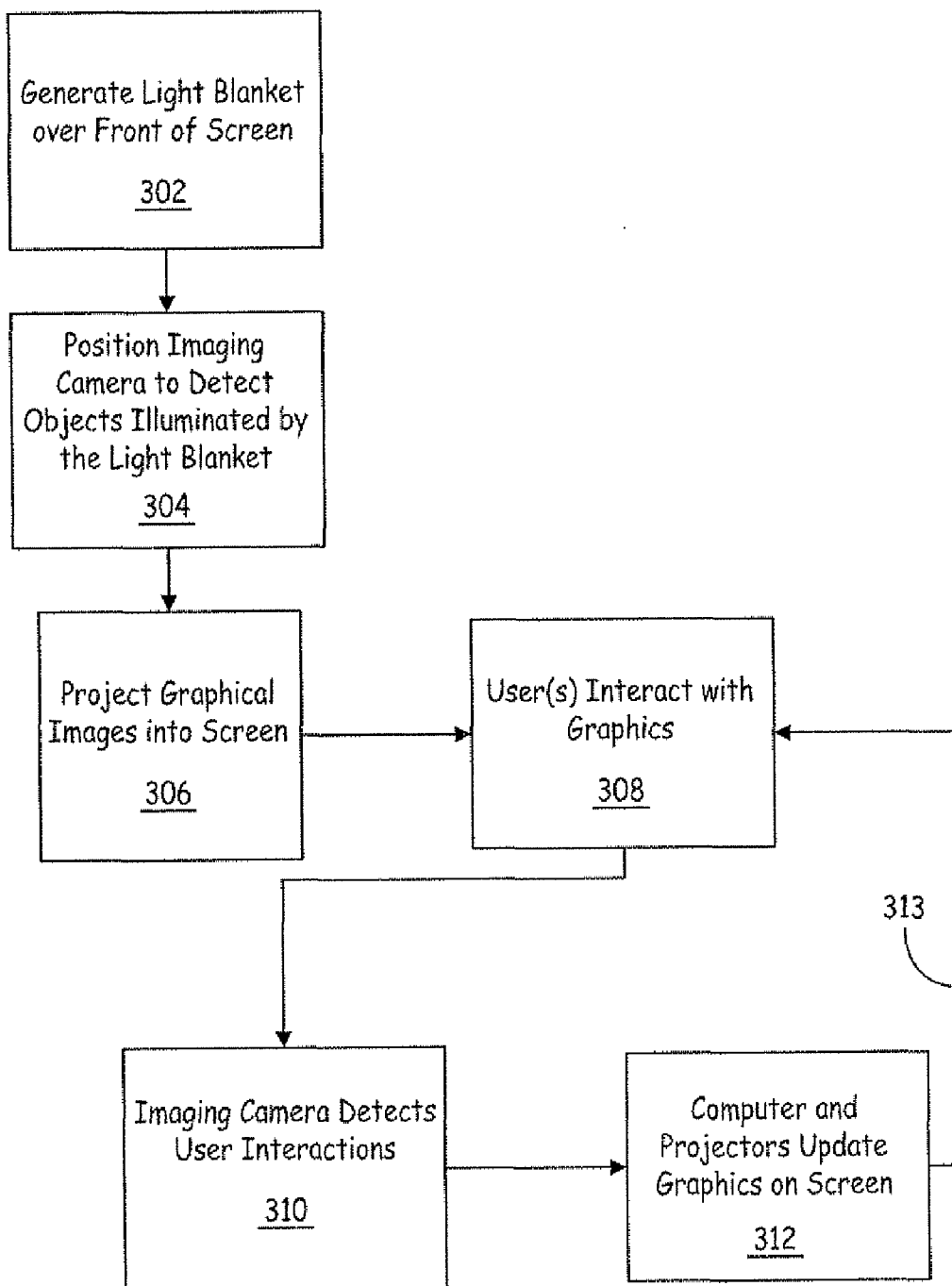
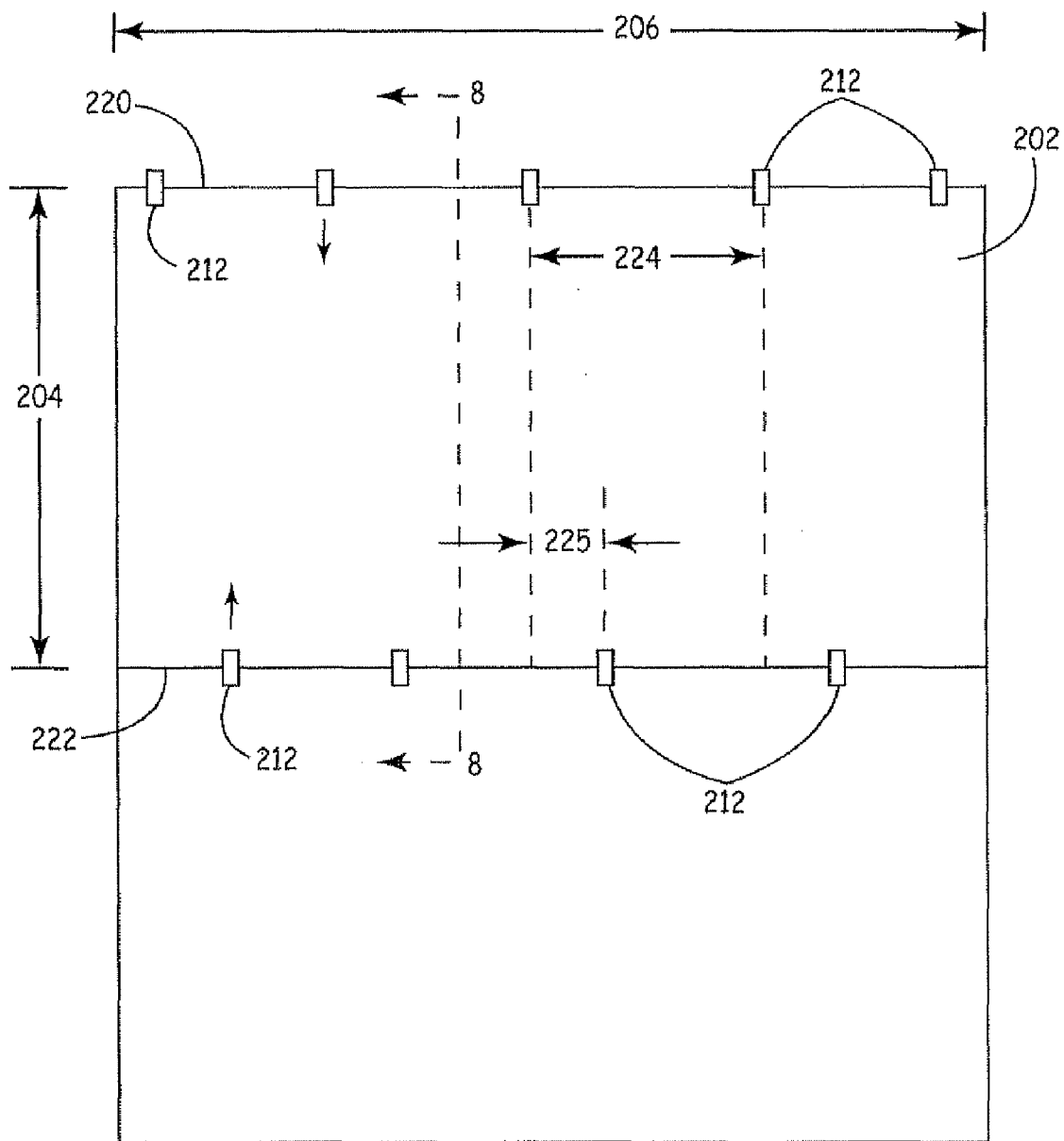

FIG. 3



200

FIG. 4

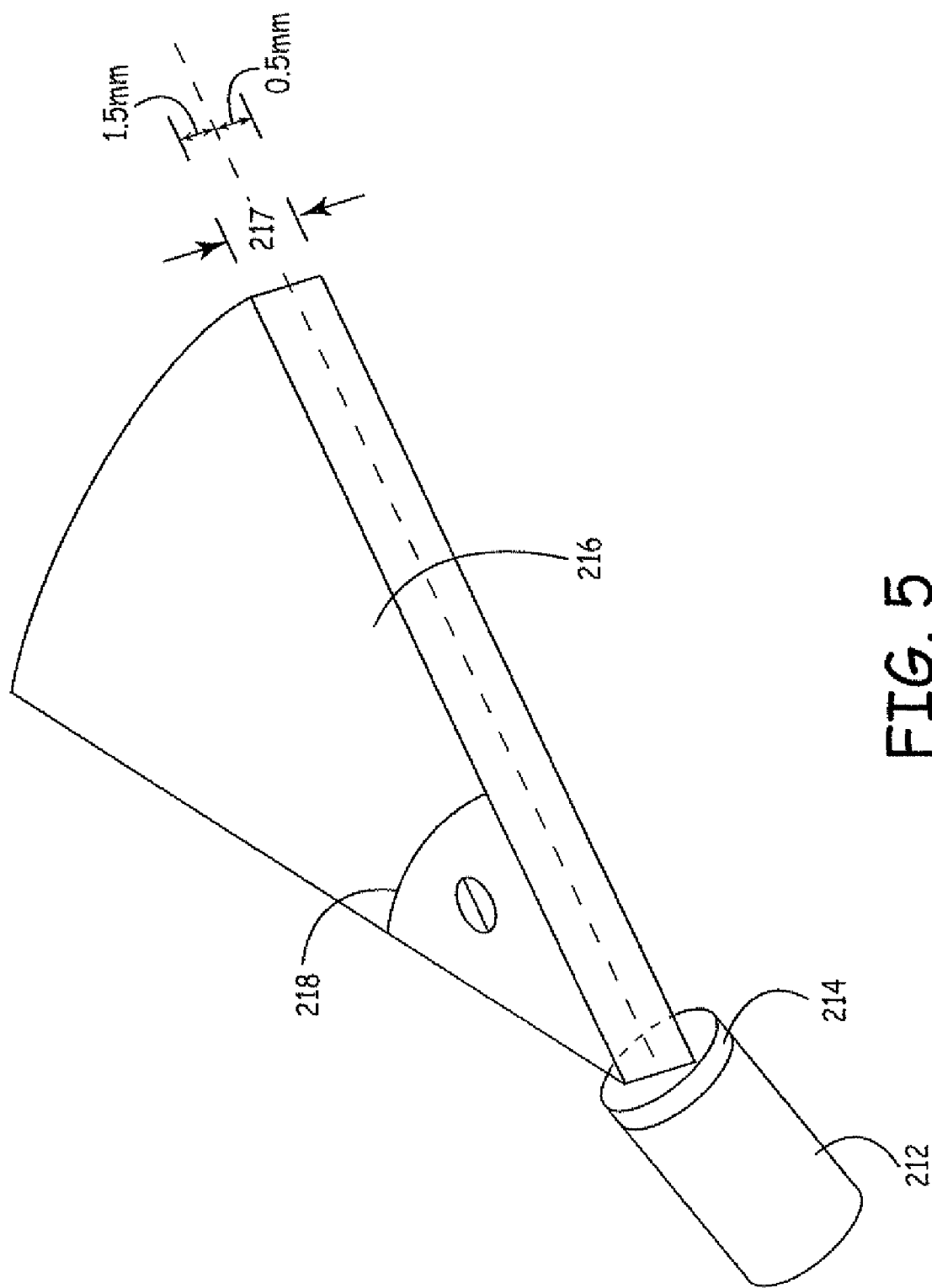

FIG. 5

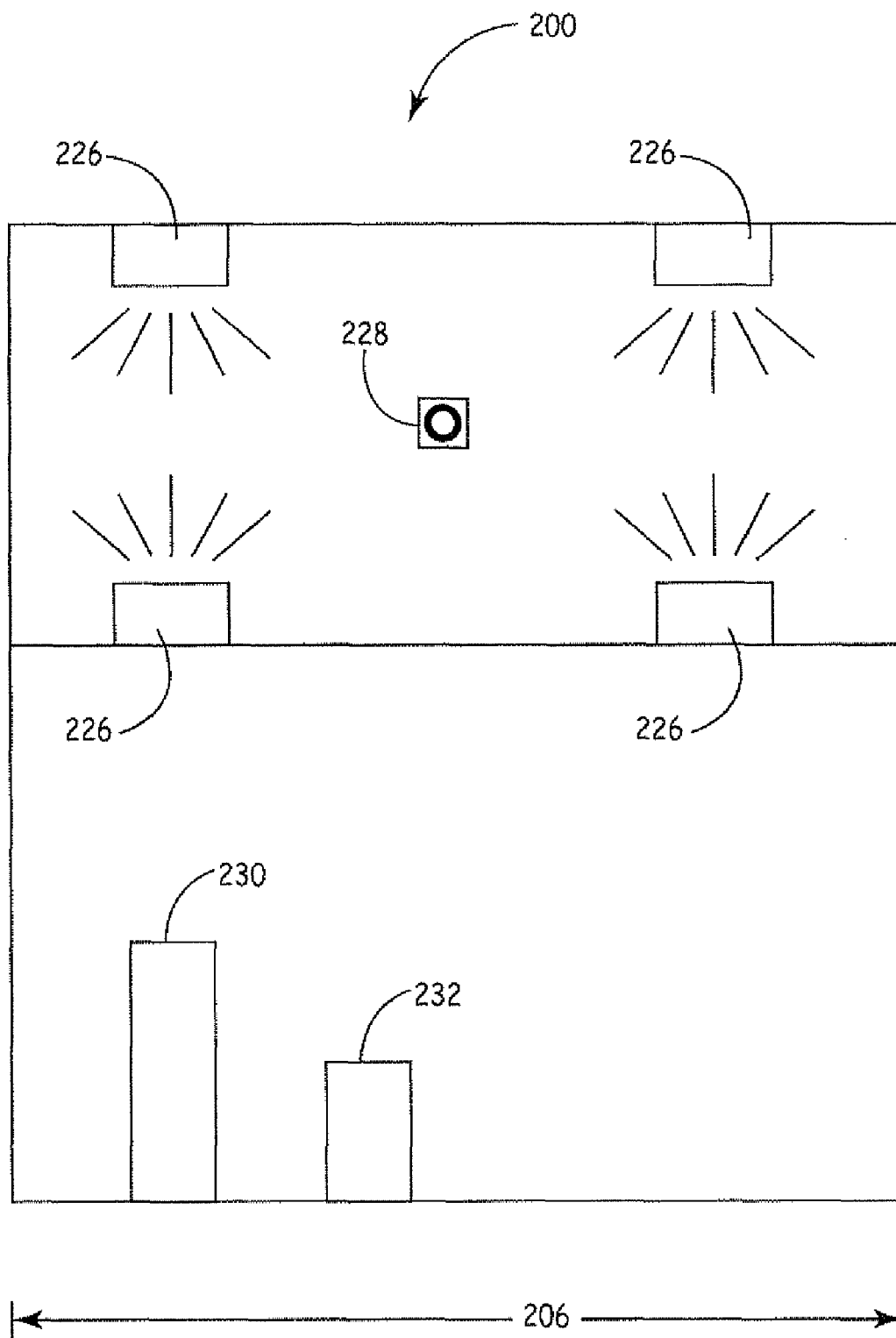

FIG. 6

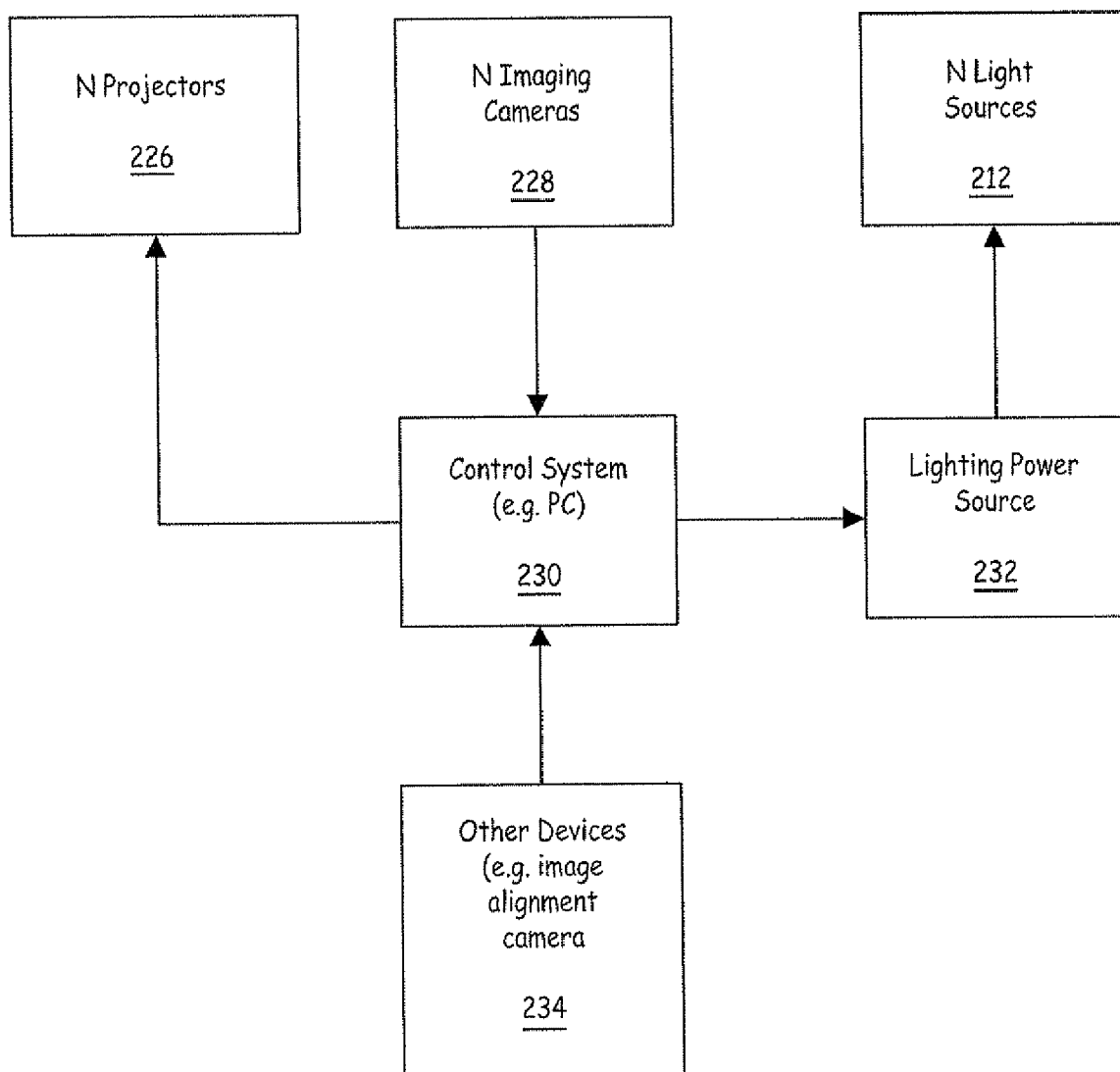

FIG. 7



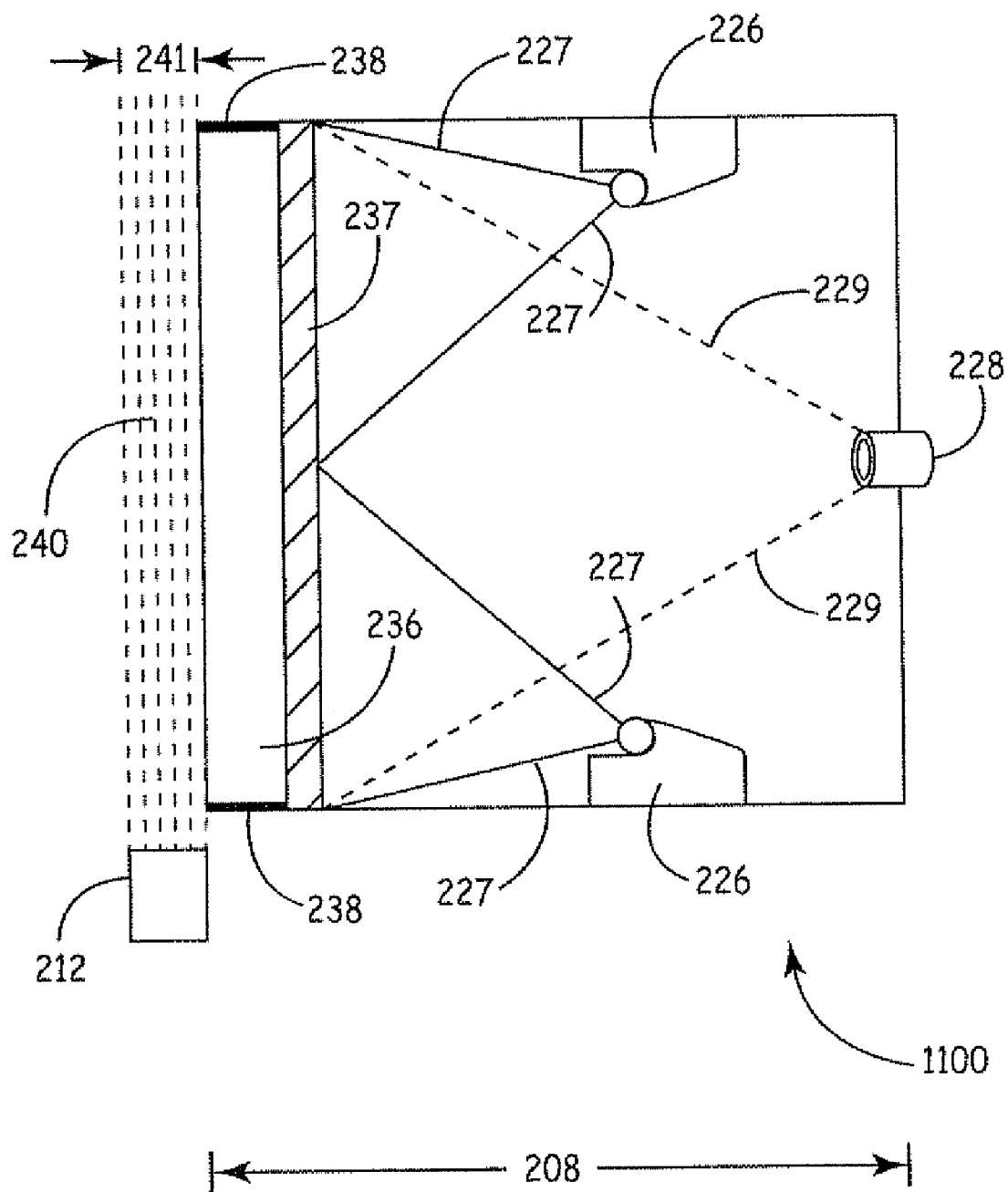

FIG. 8

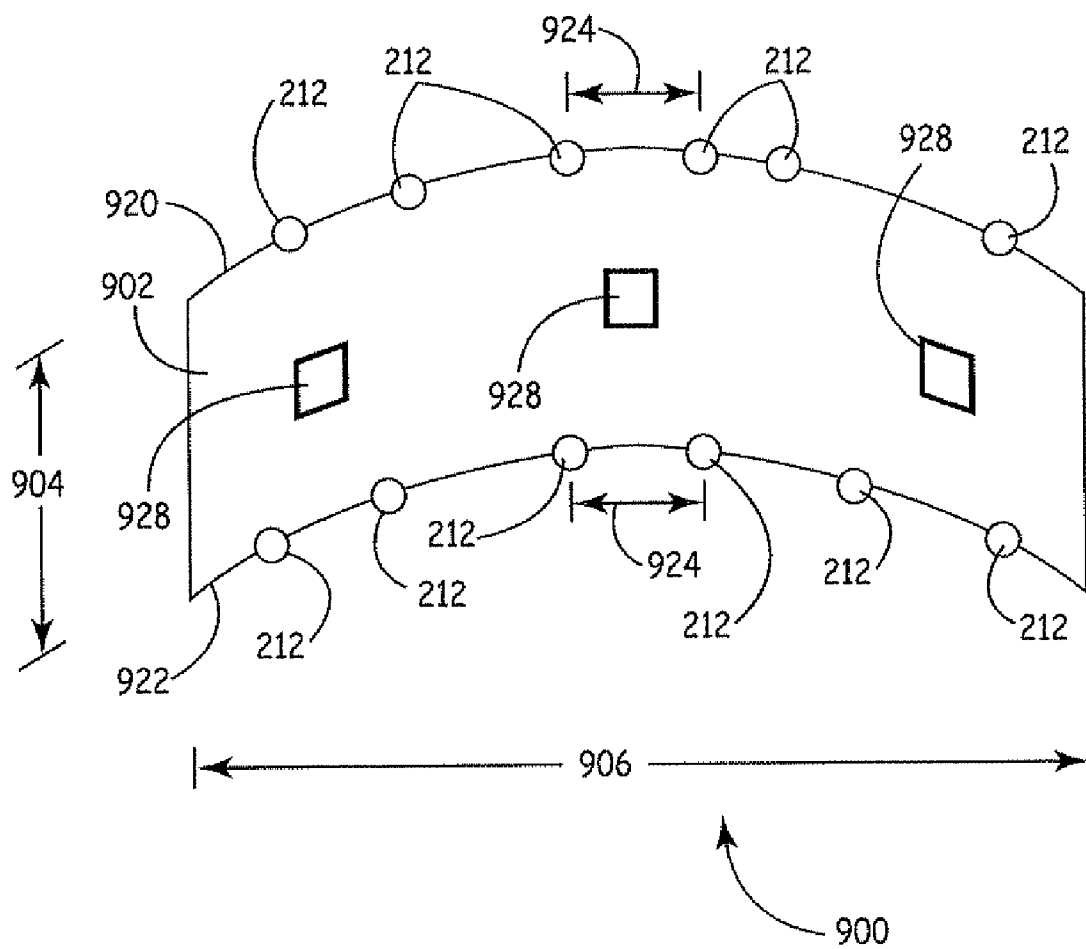

FIG. 9

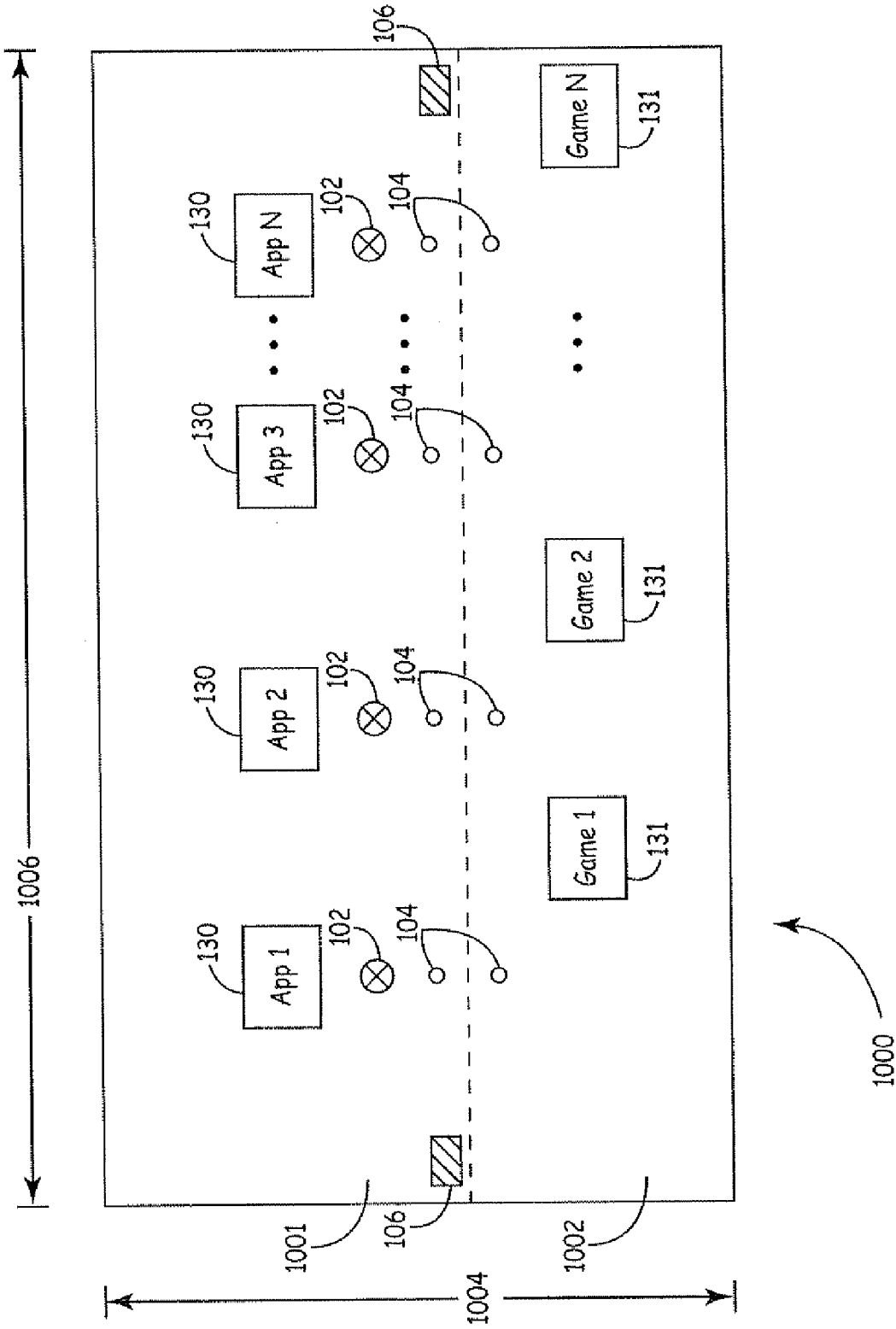

FIG. 10

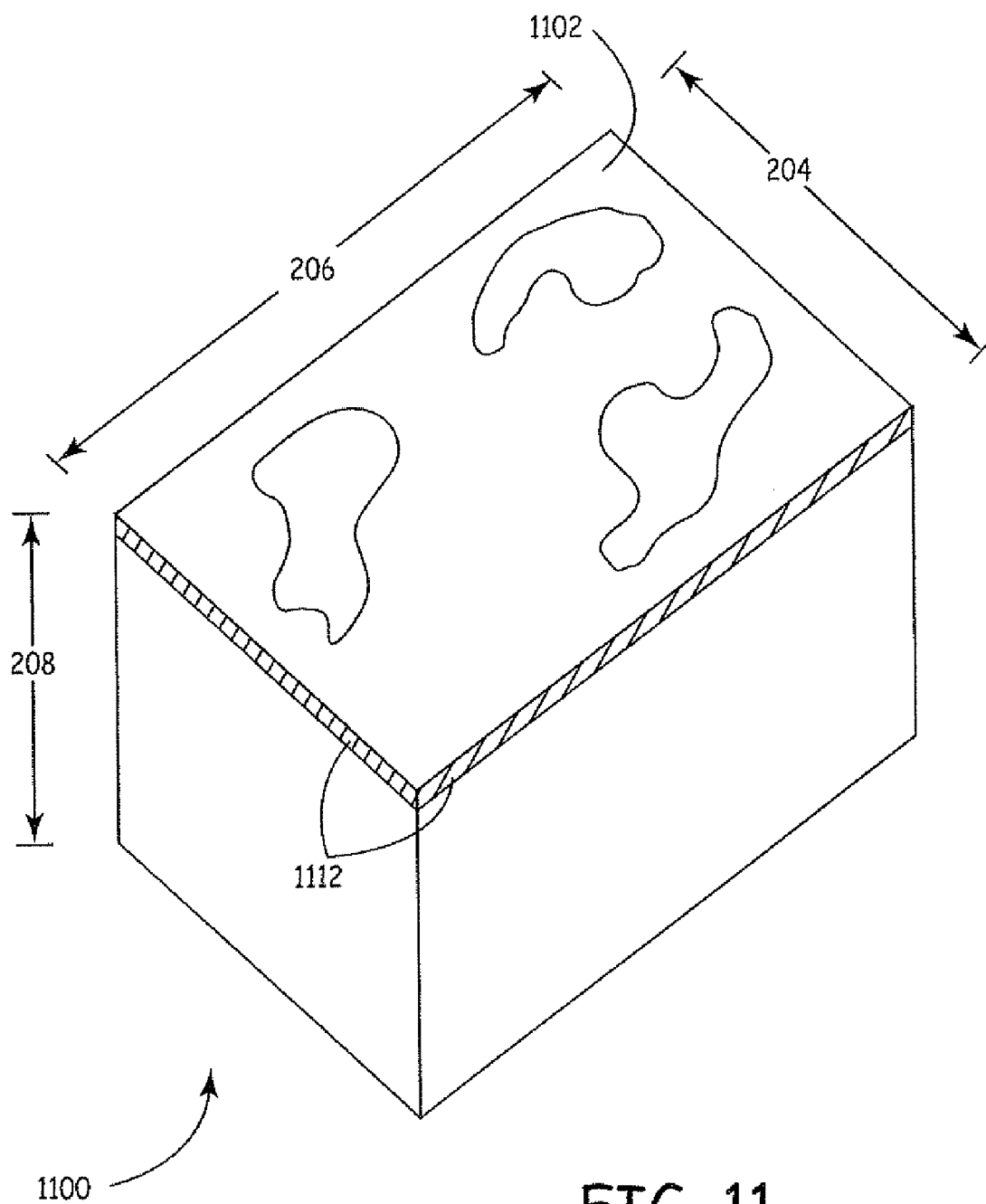

FIG. 11

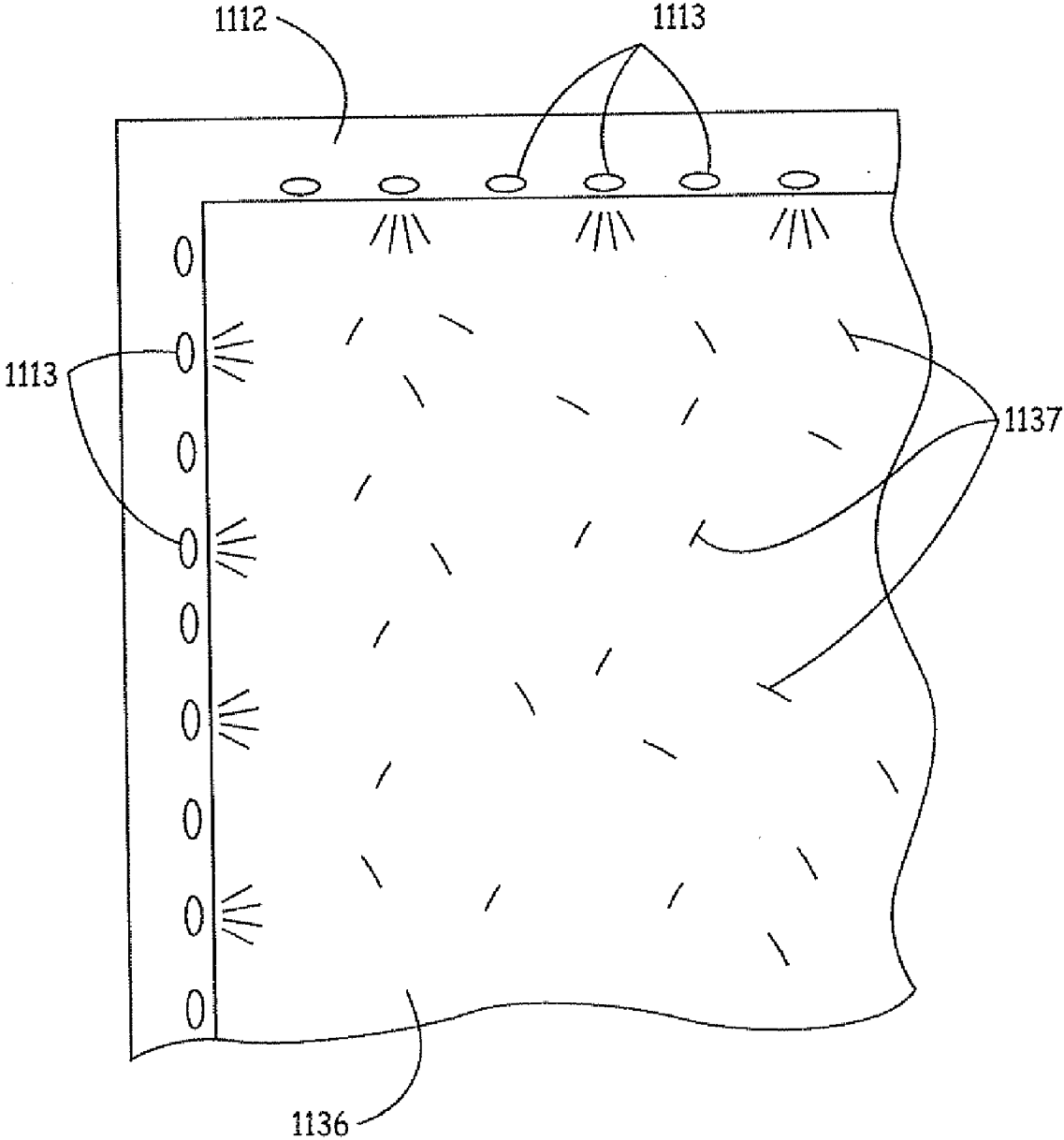

FIG. 12

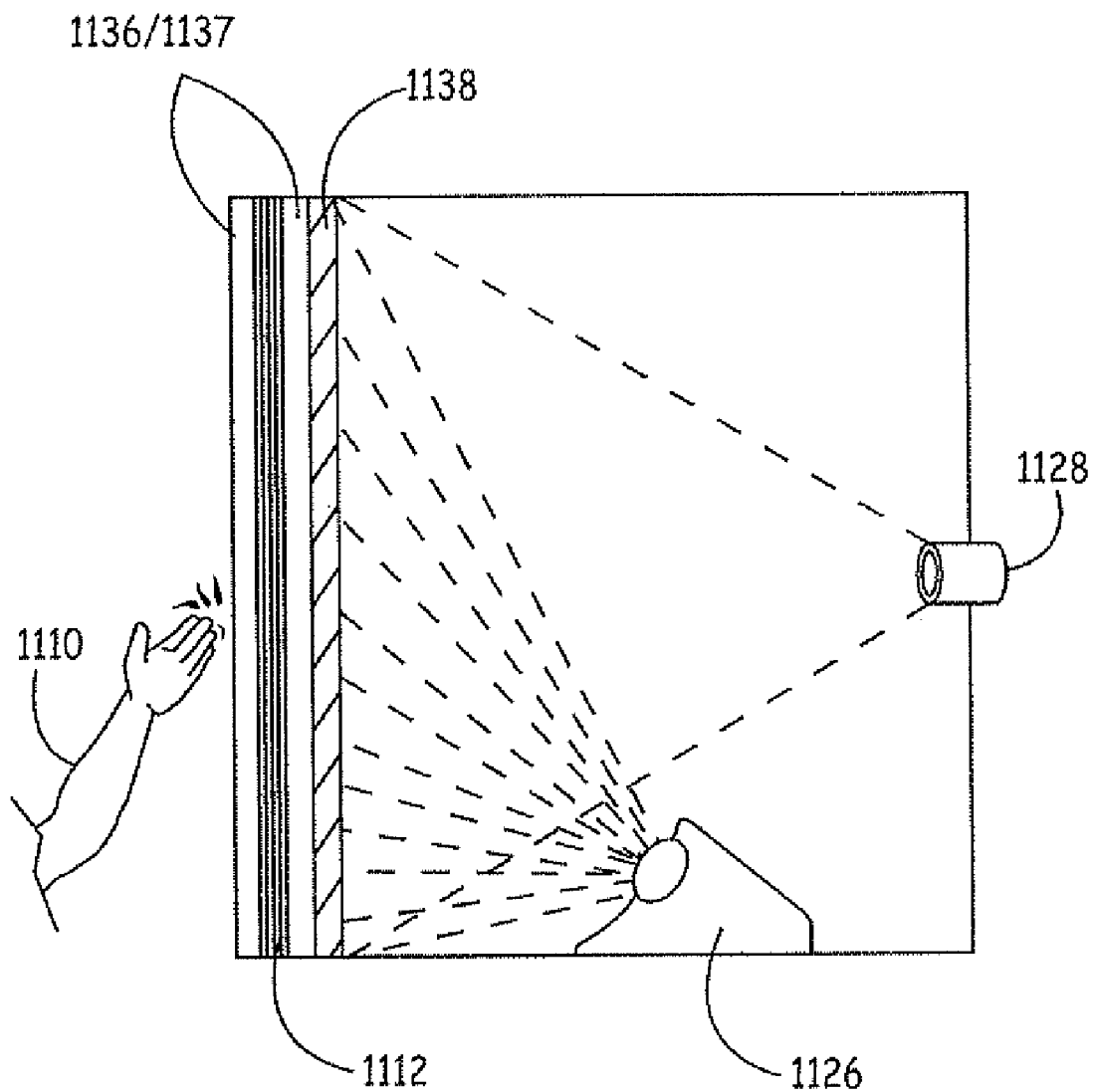

FIG. 13

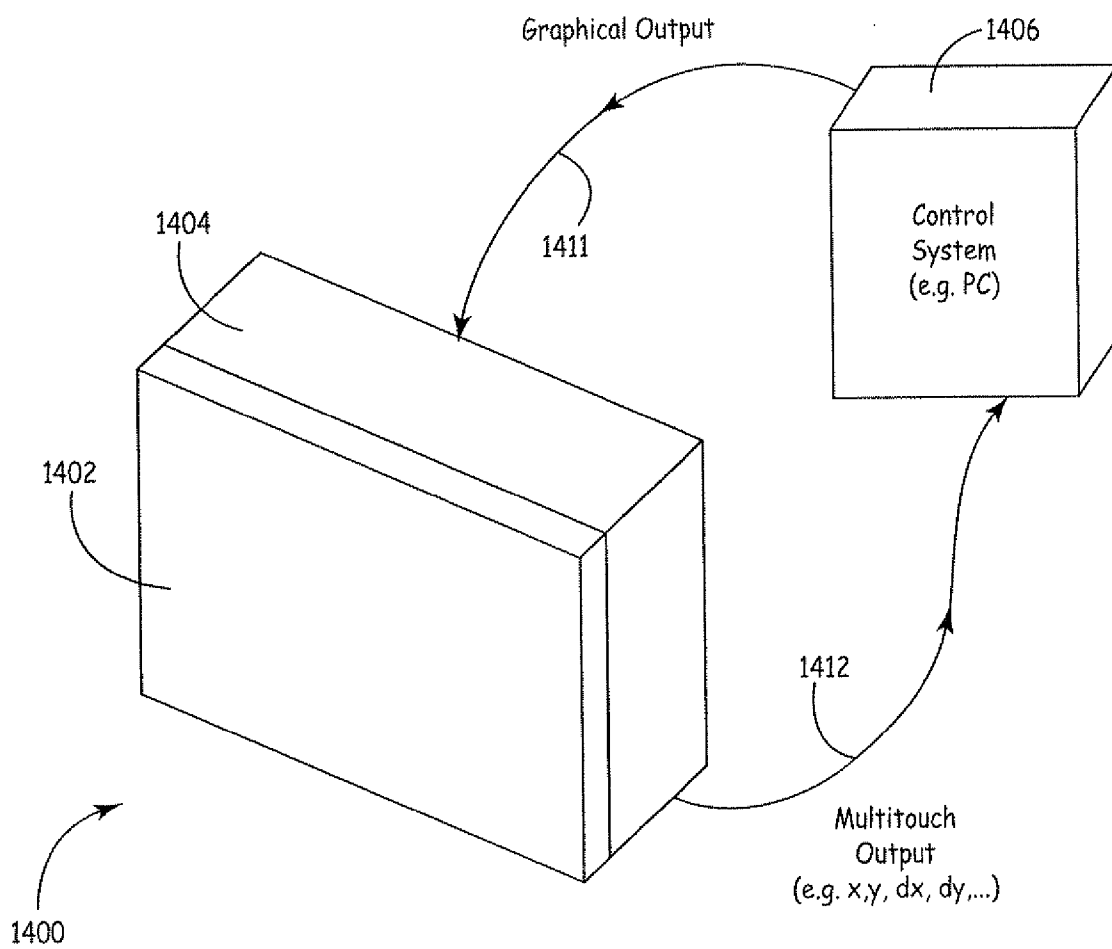

FIG. 14

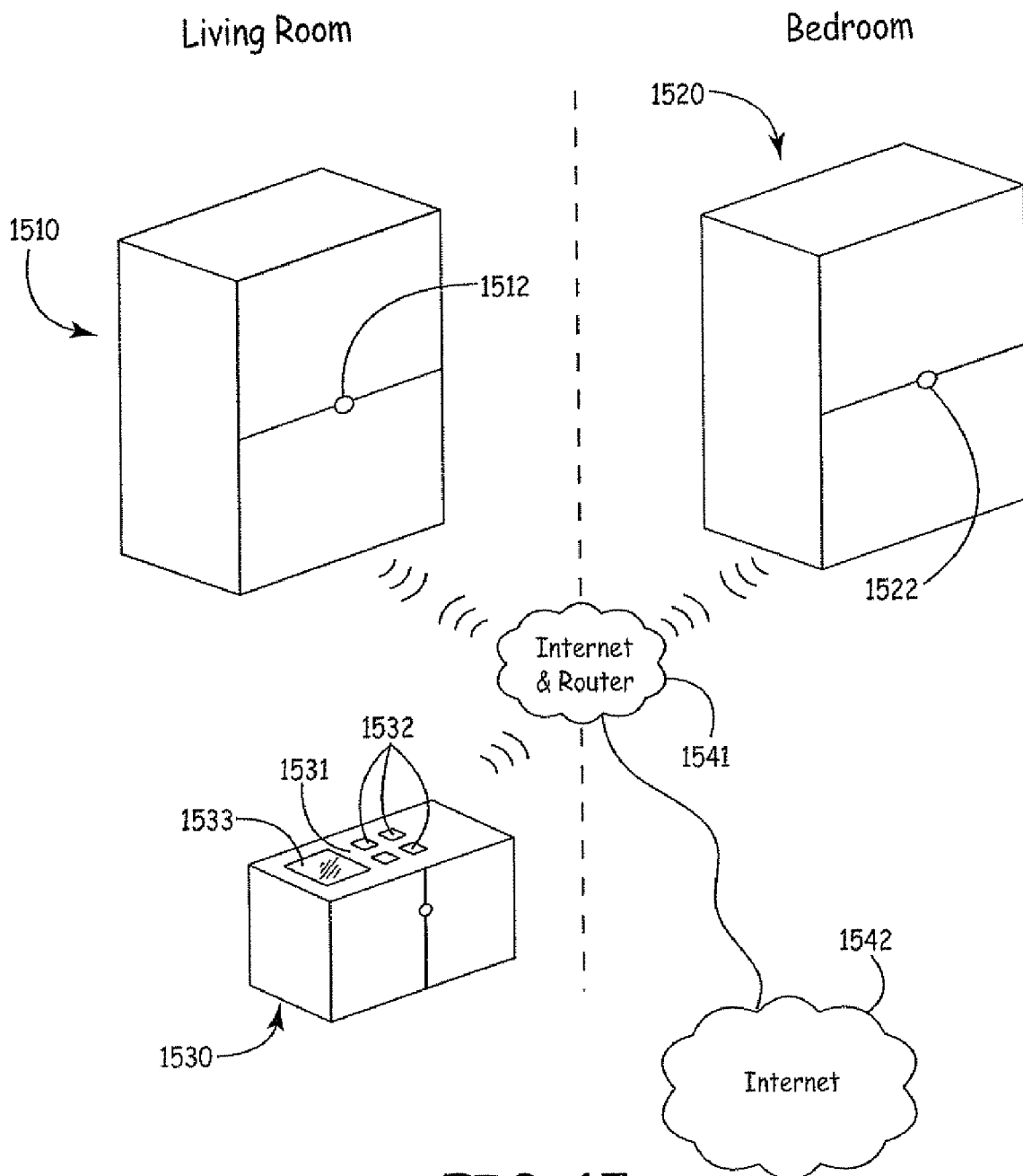

FIG. 15



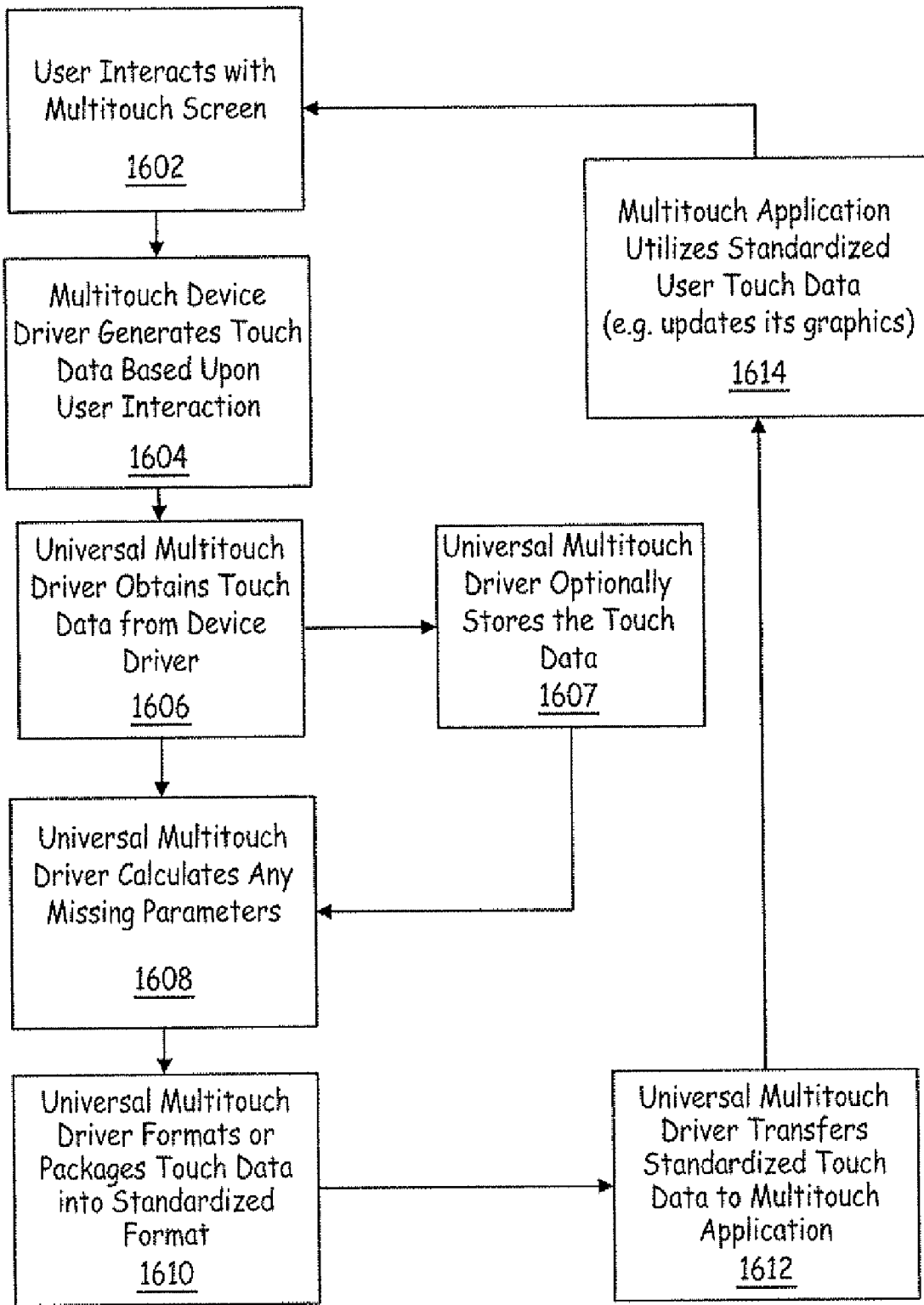

FIG. 16

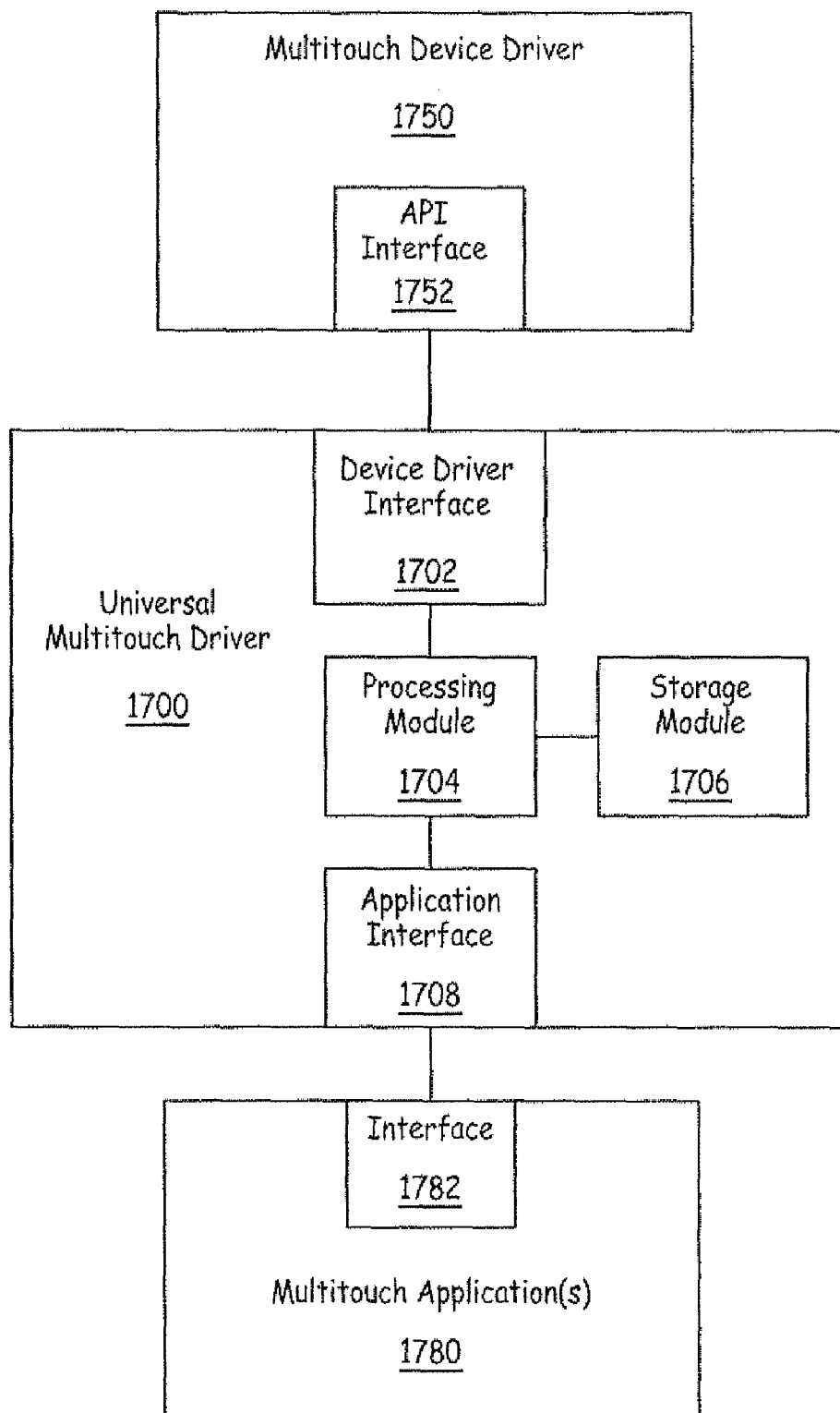

FIG. 17

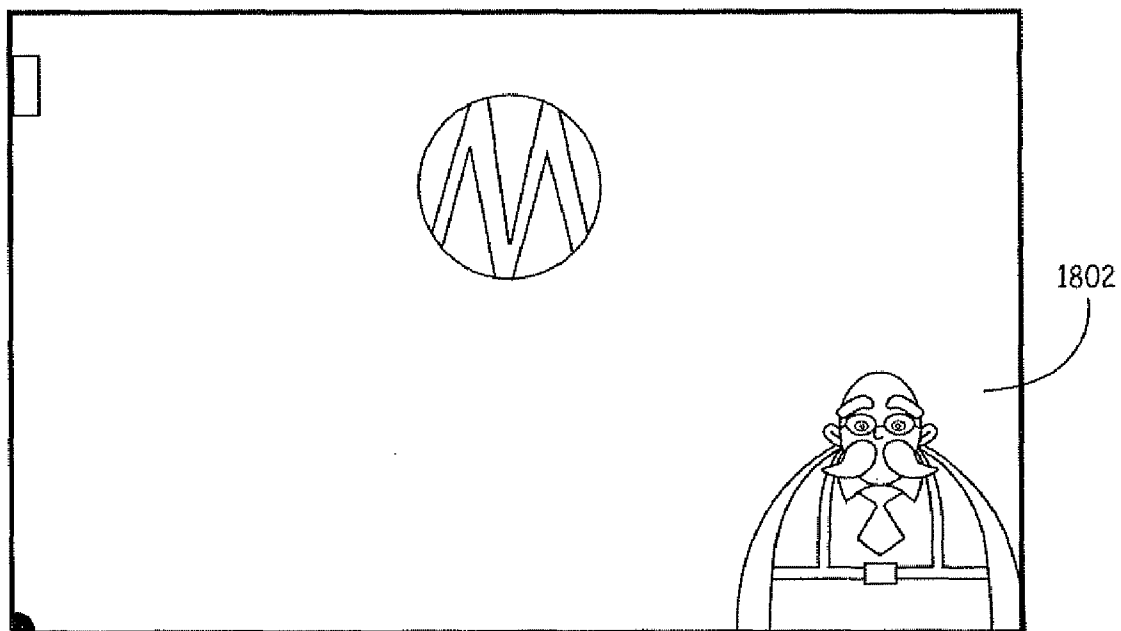

FIG. 18-1

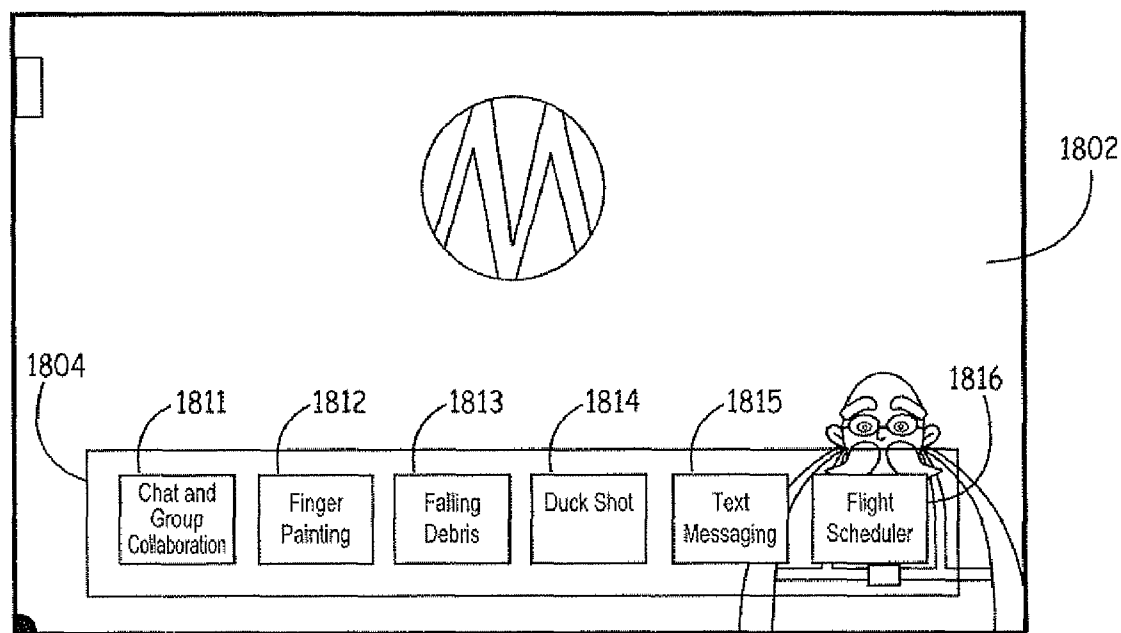

FIG. 18-2

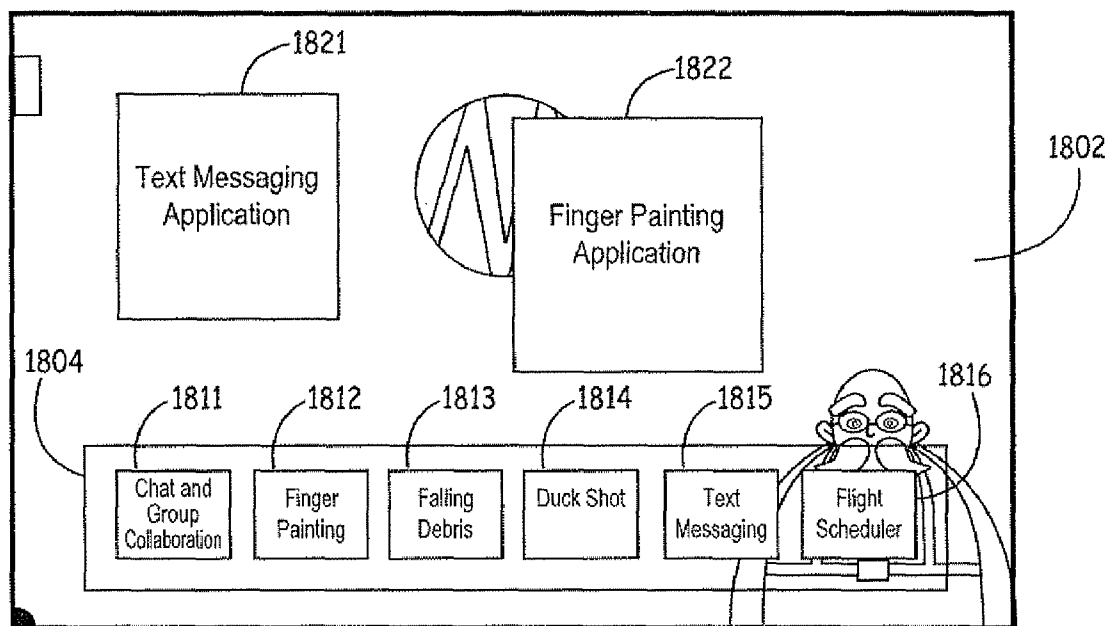

FIG. 18-3

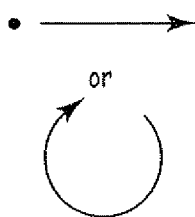

FIG. 19-1

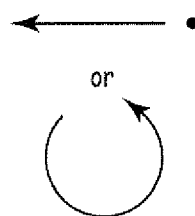

FIG. 19-2



FIG. 19-3



FIG. 19-4

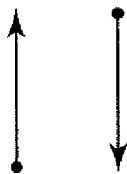

FIG. 19-5

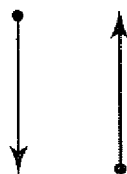

FIG. 19-6

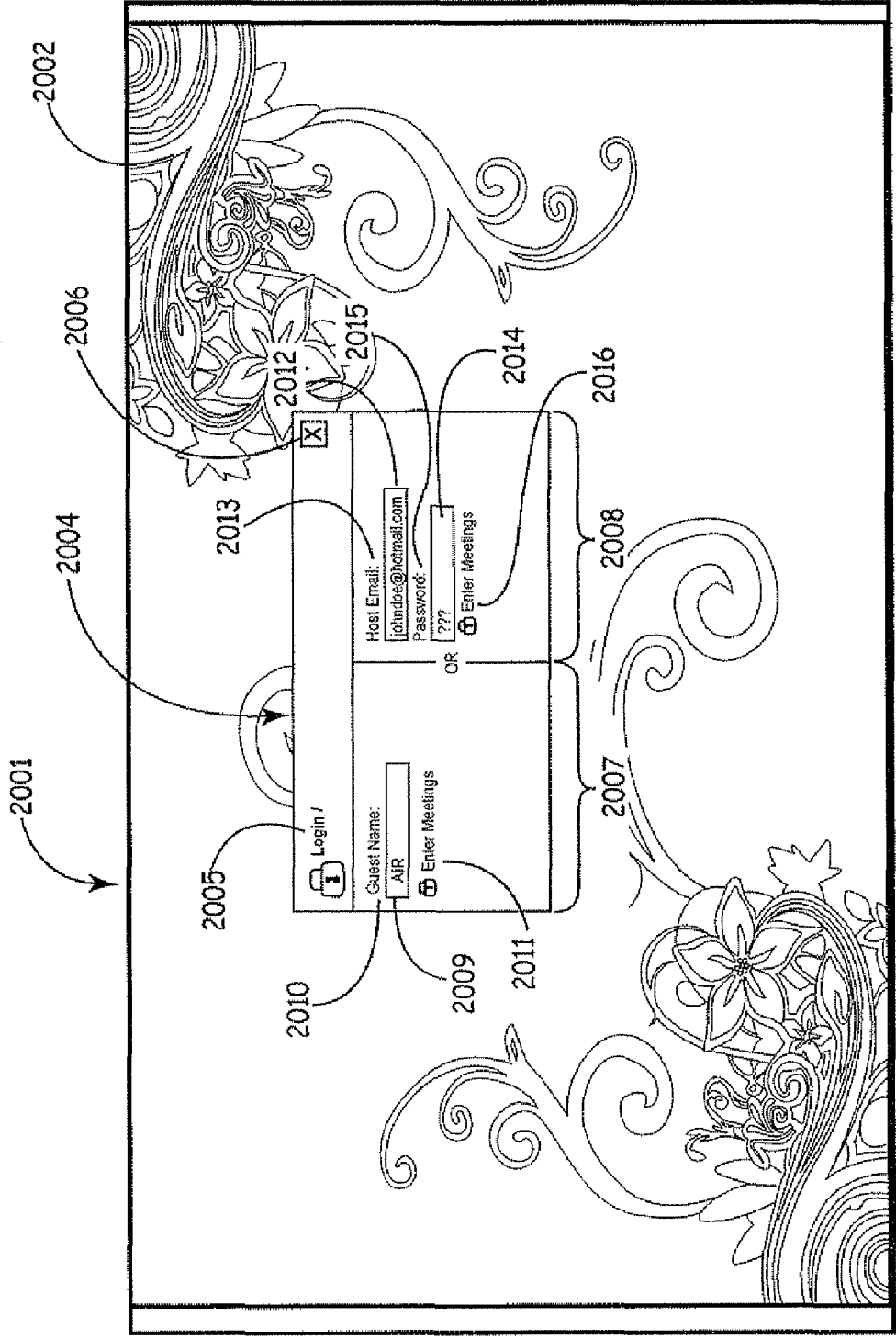

FIG. 20-1

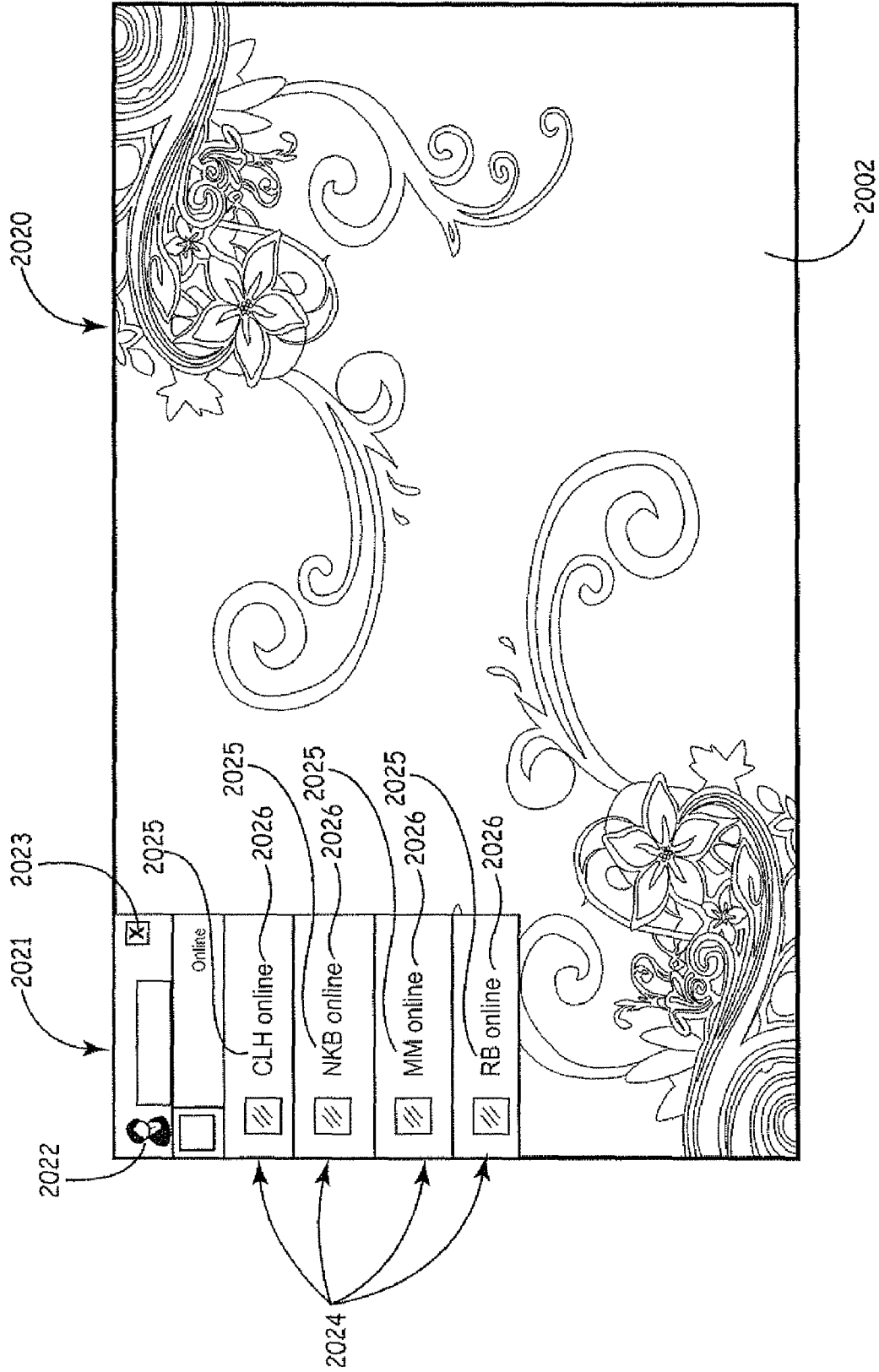

FIG. 20-2

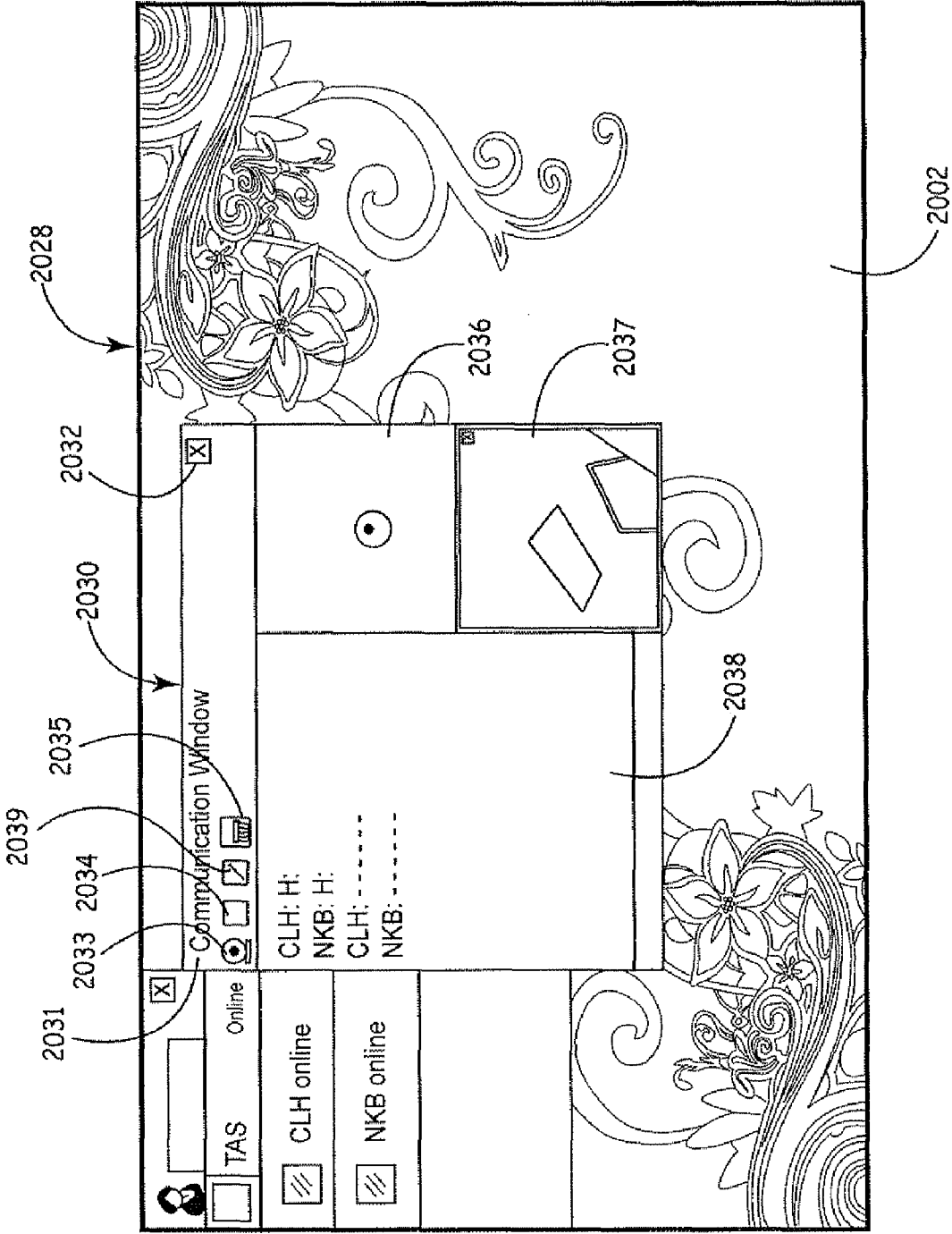

FIG. 20-3



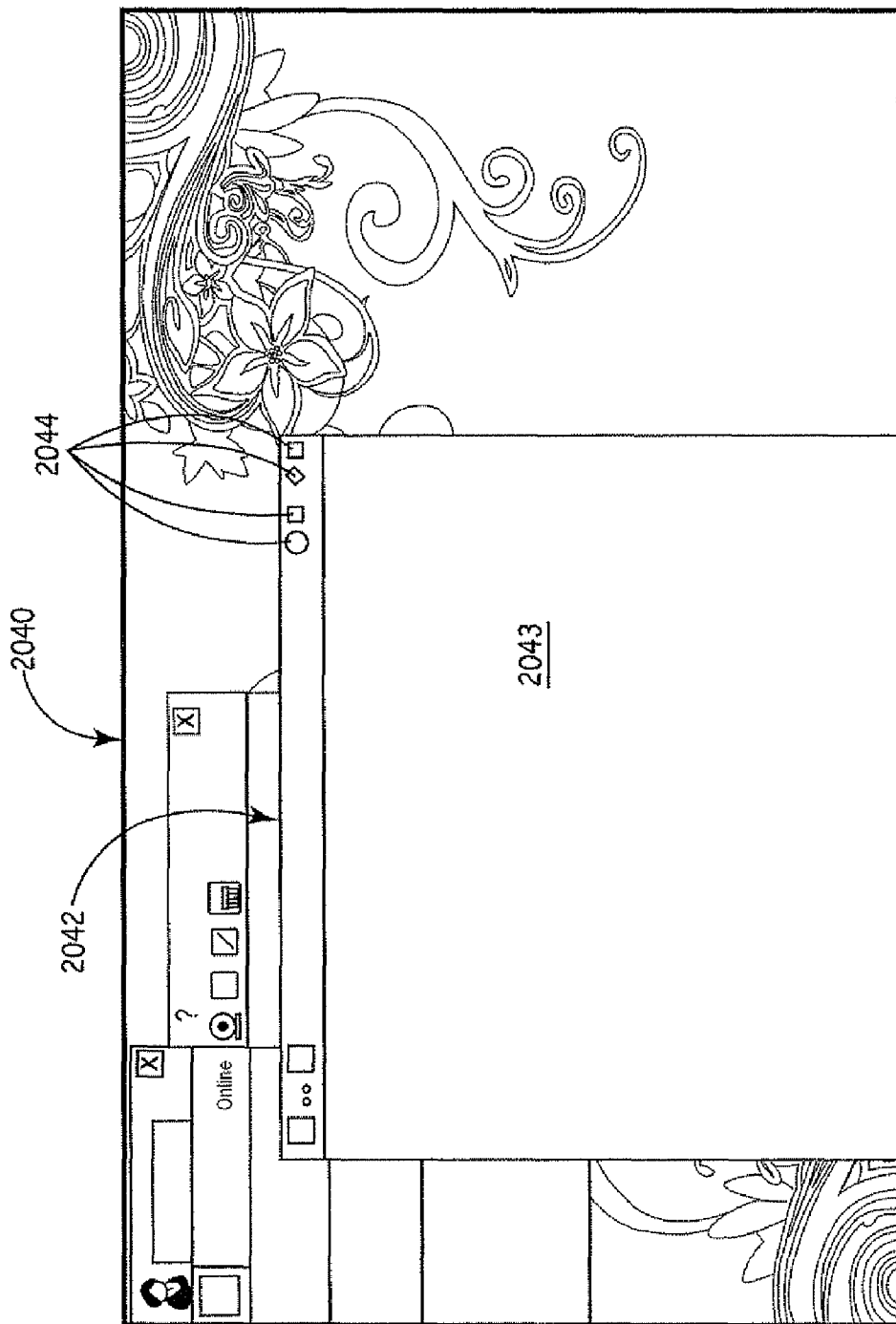

FIG. 20-4

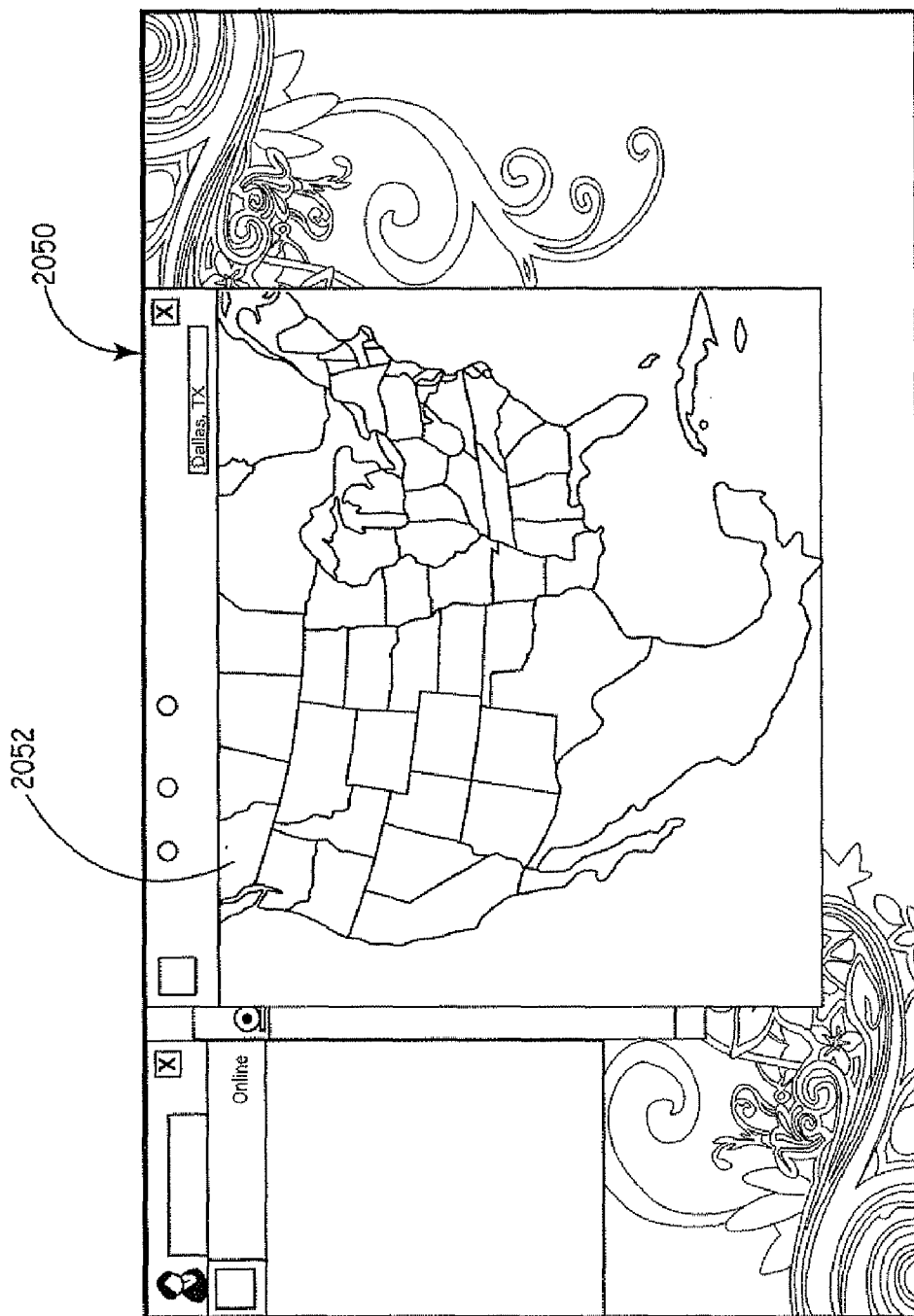

FIG. 20-5

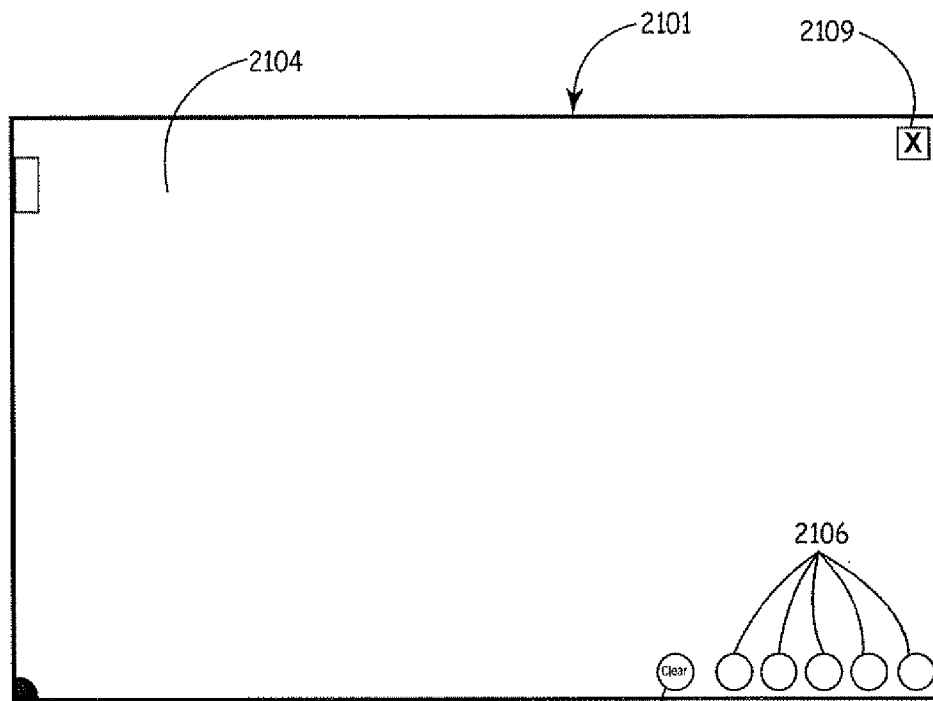

FIG. 21-1

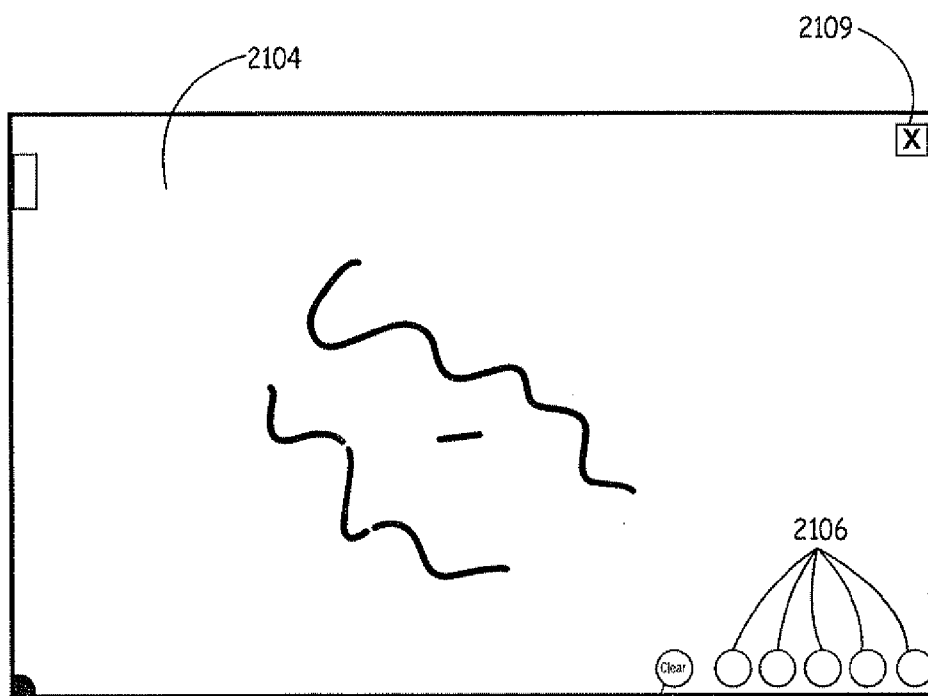

FIG. 21-2

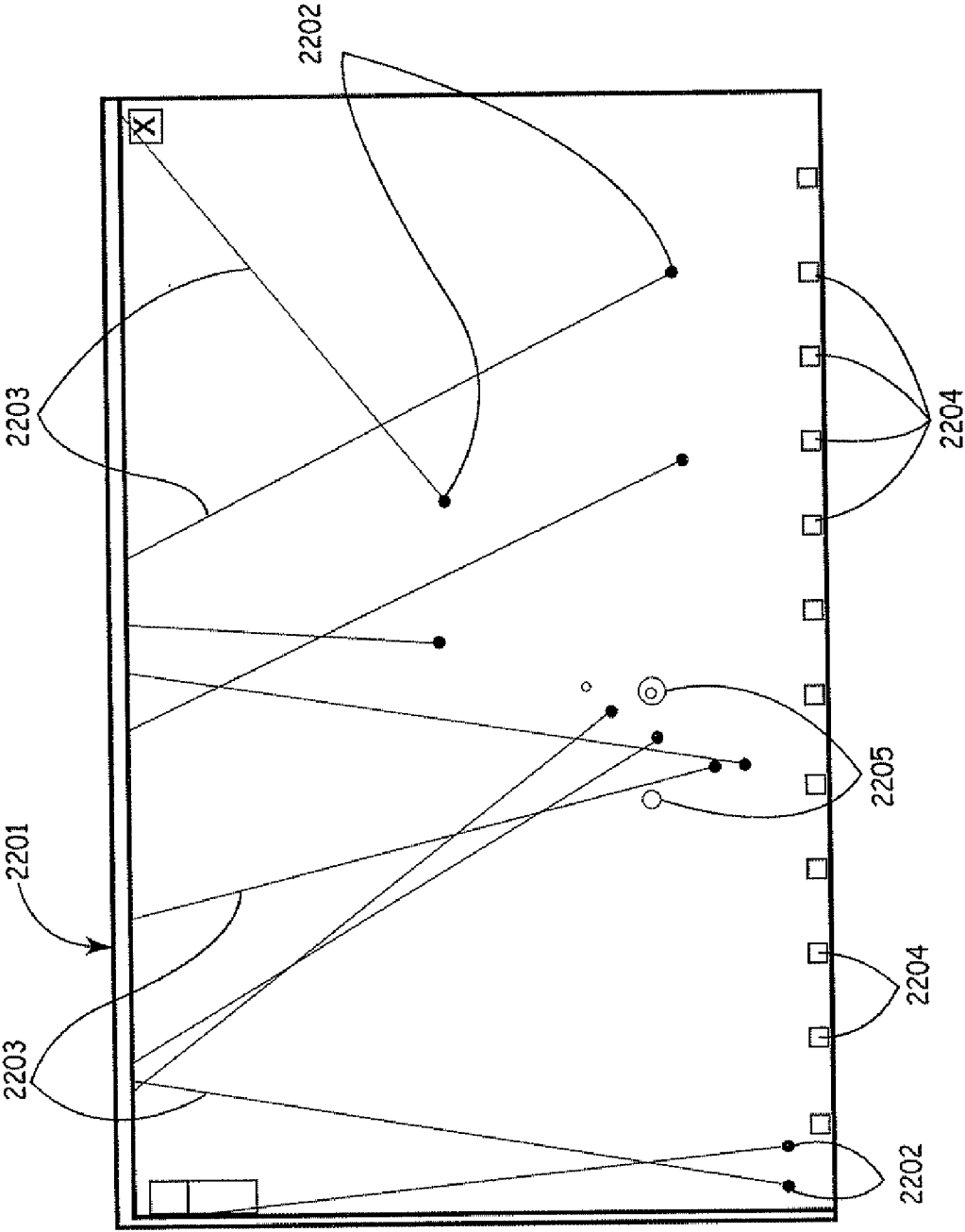

FIG. 22

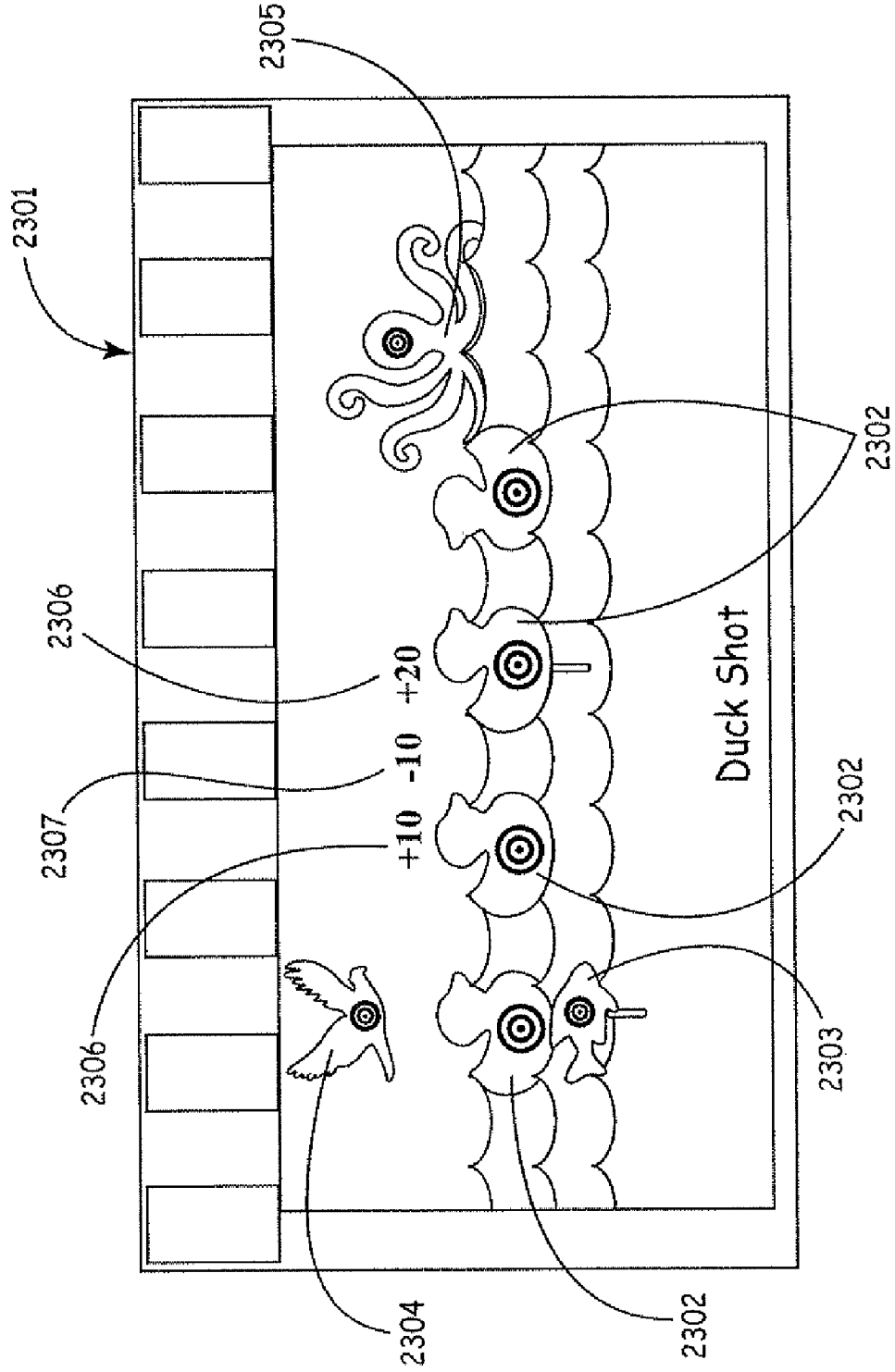

FIG. 23

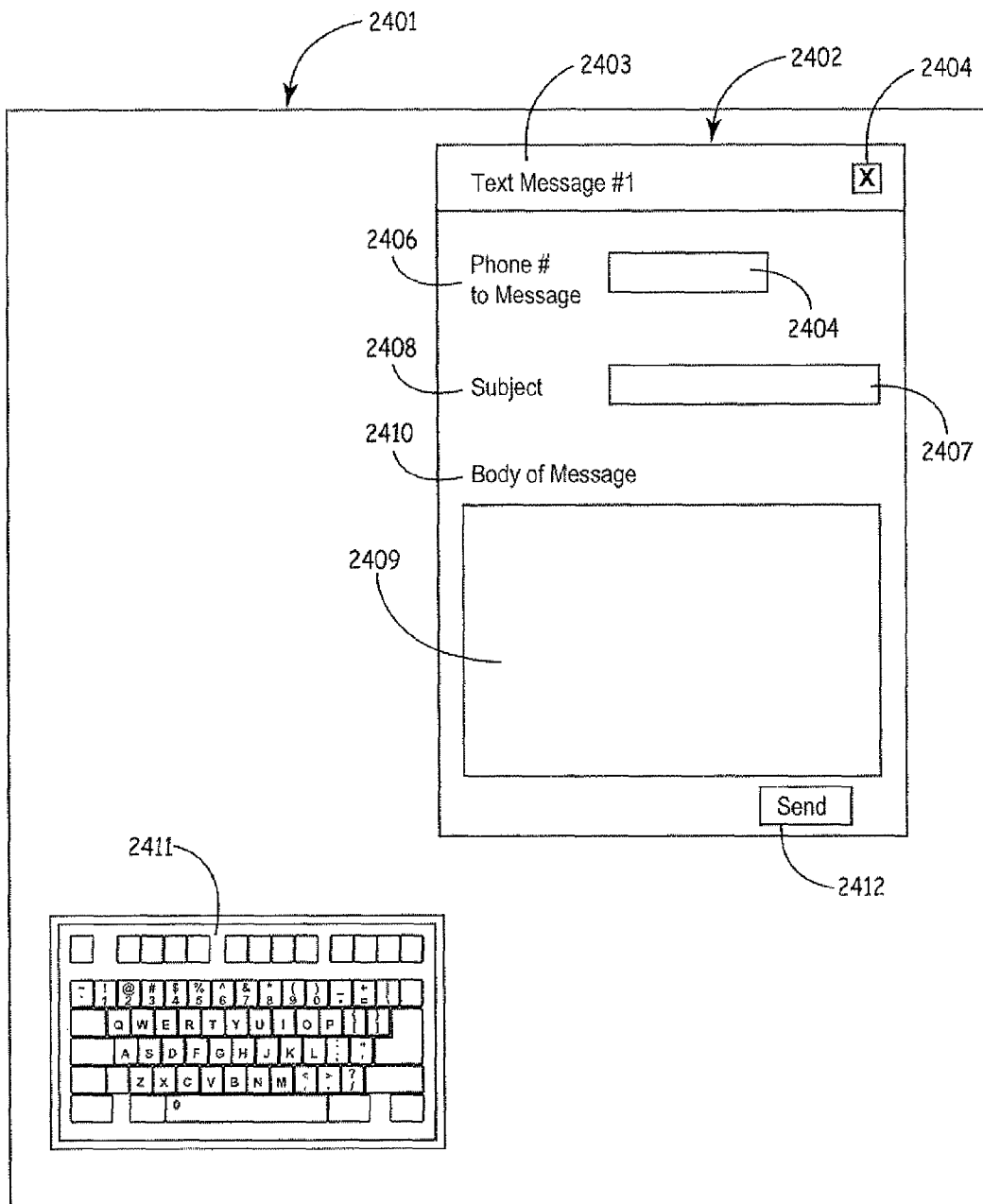

FIG. 24

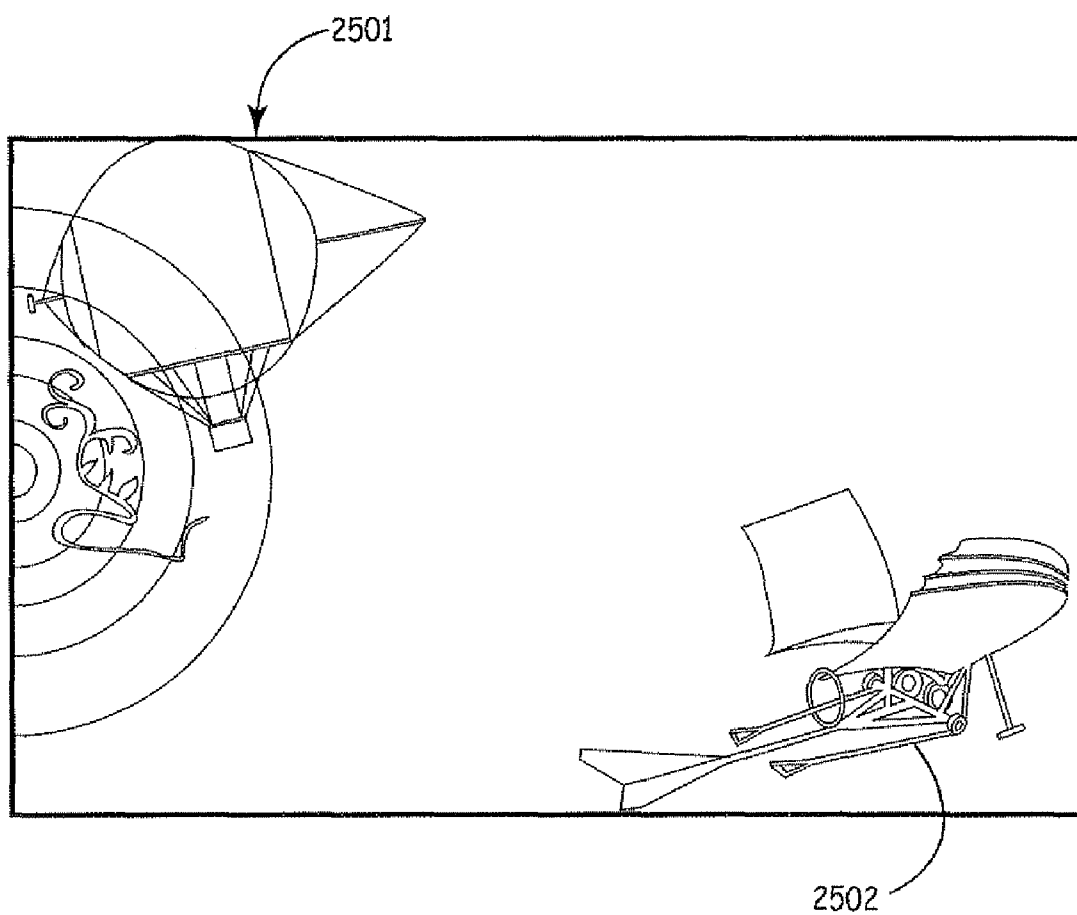

FIG. 25-1

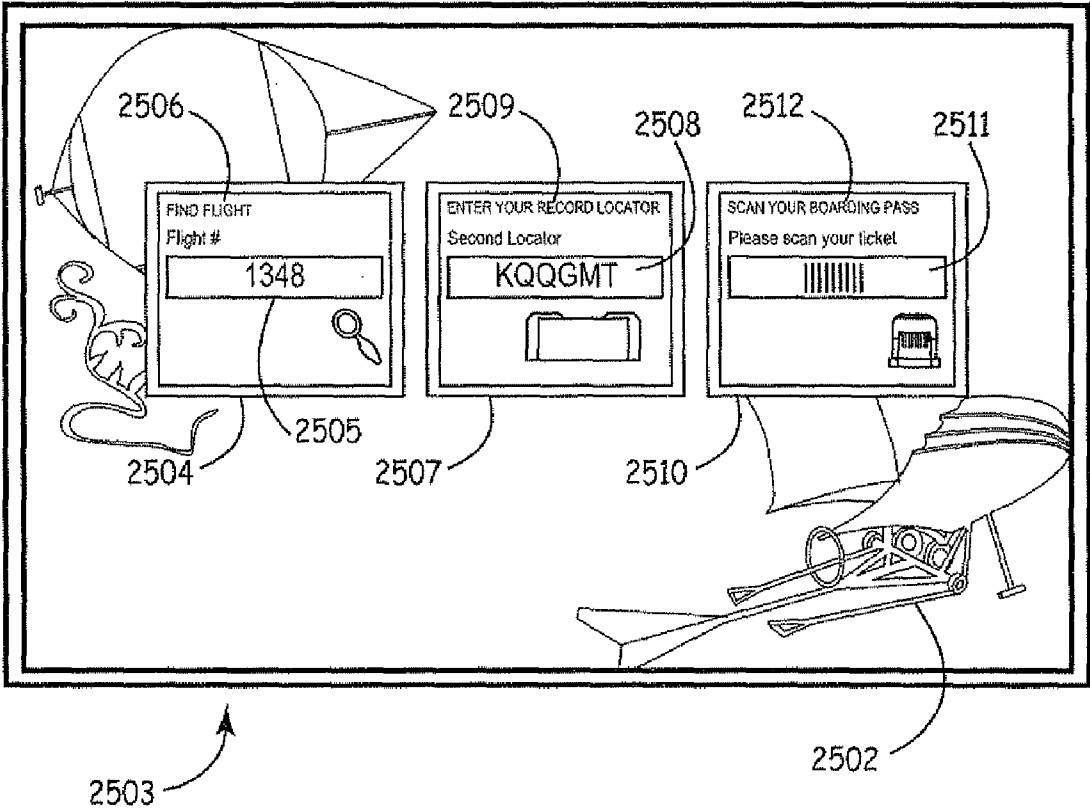

FIG. 25-2



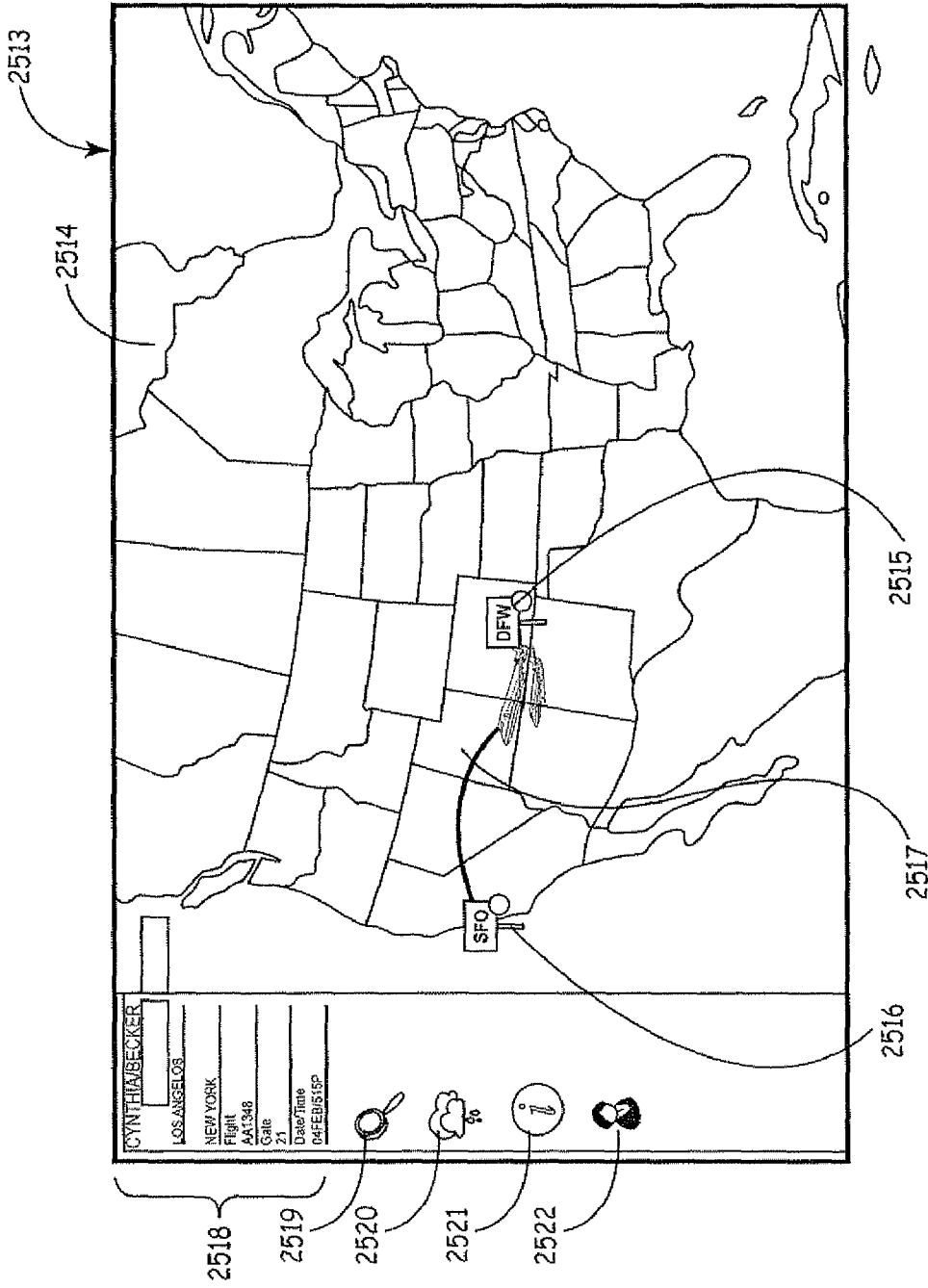

FIG. 25-3

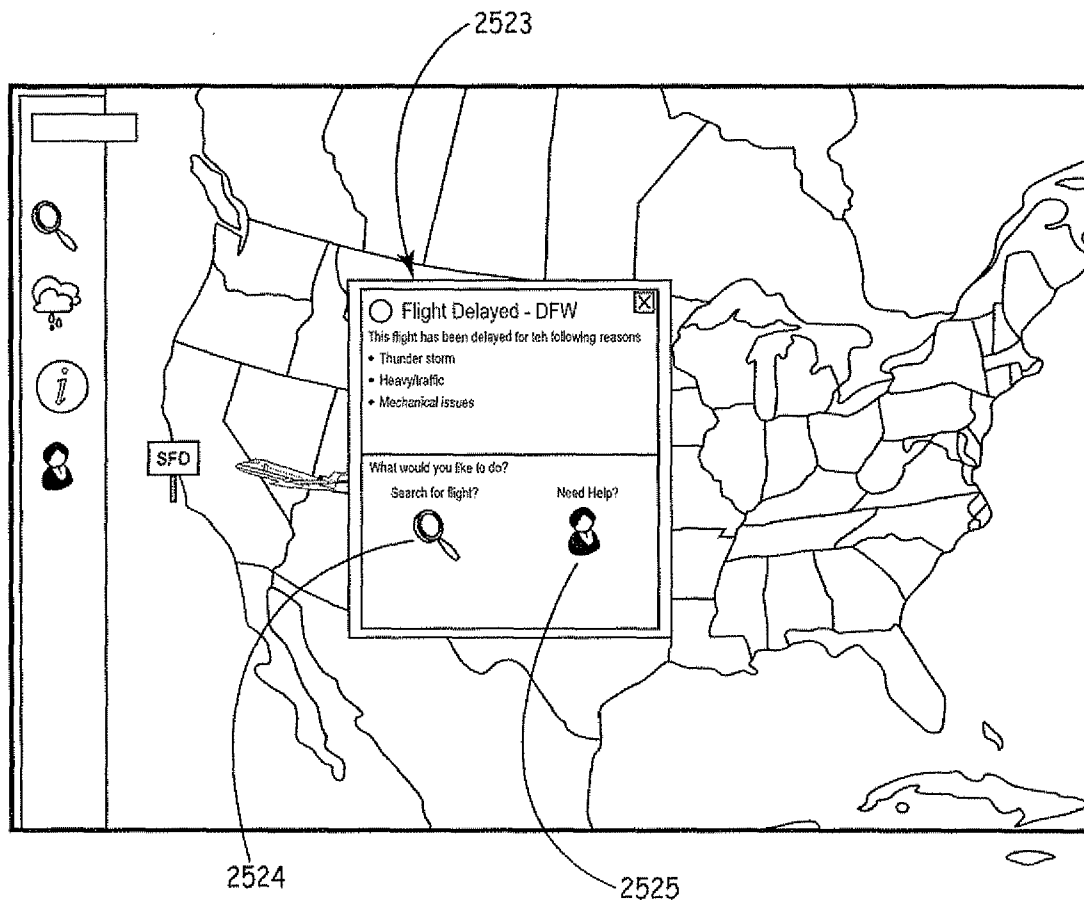

FIG. 25-4

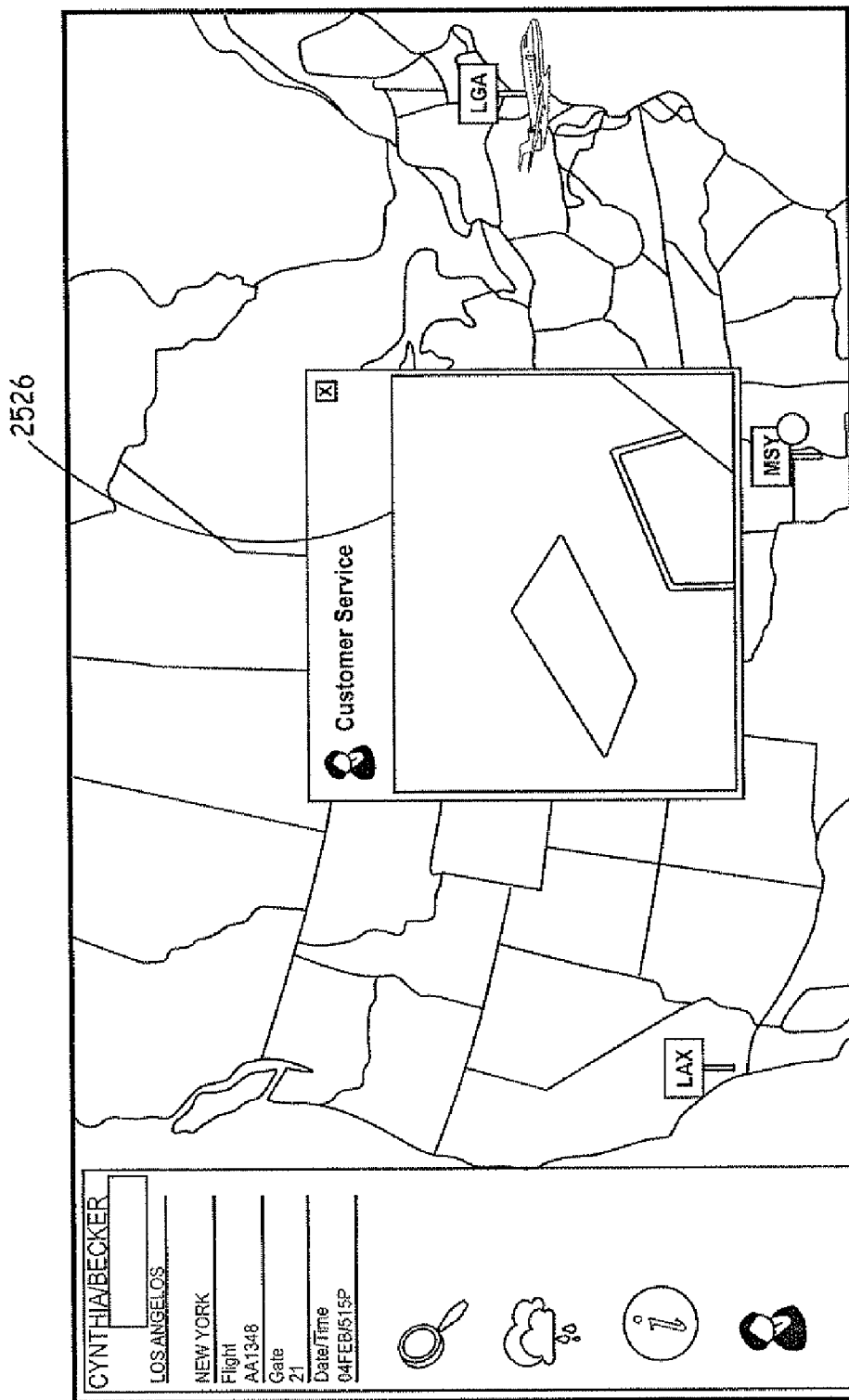

FIG. 25-5

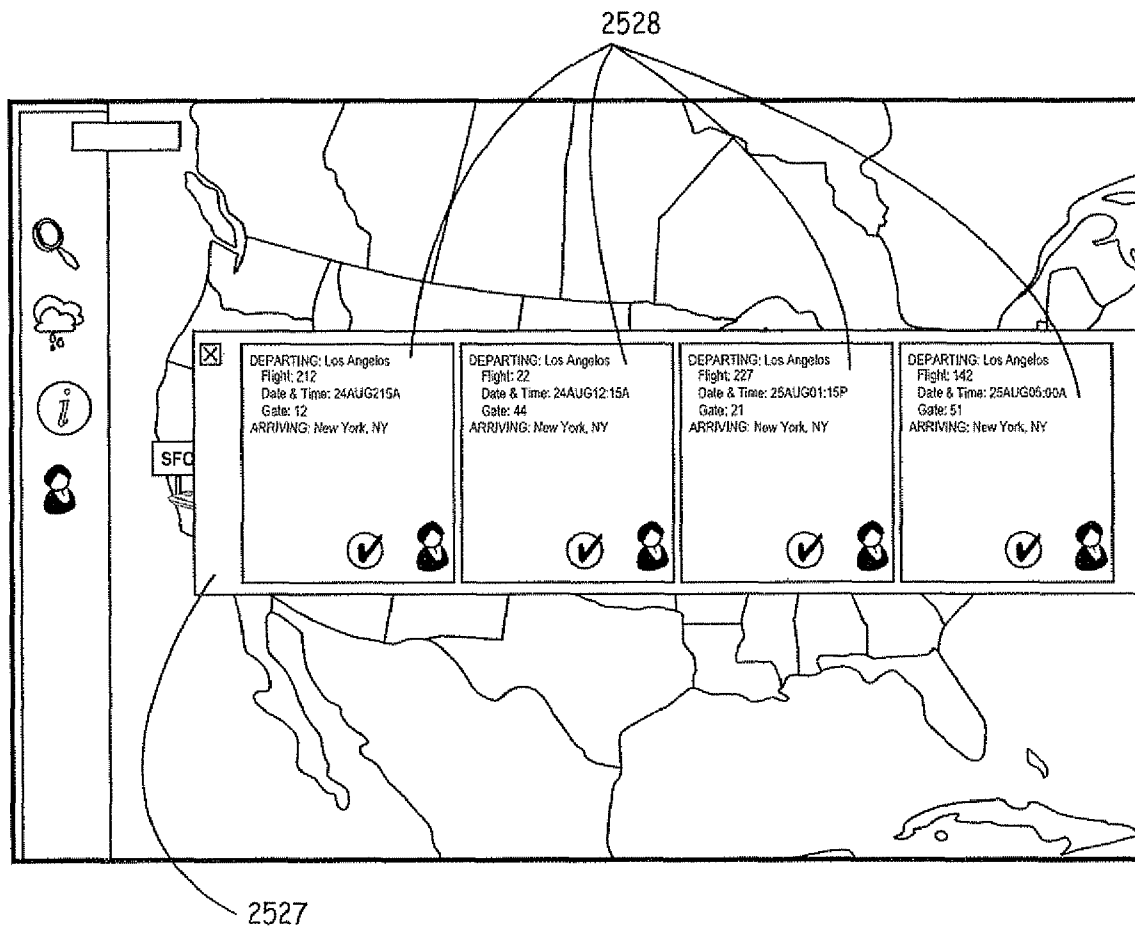
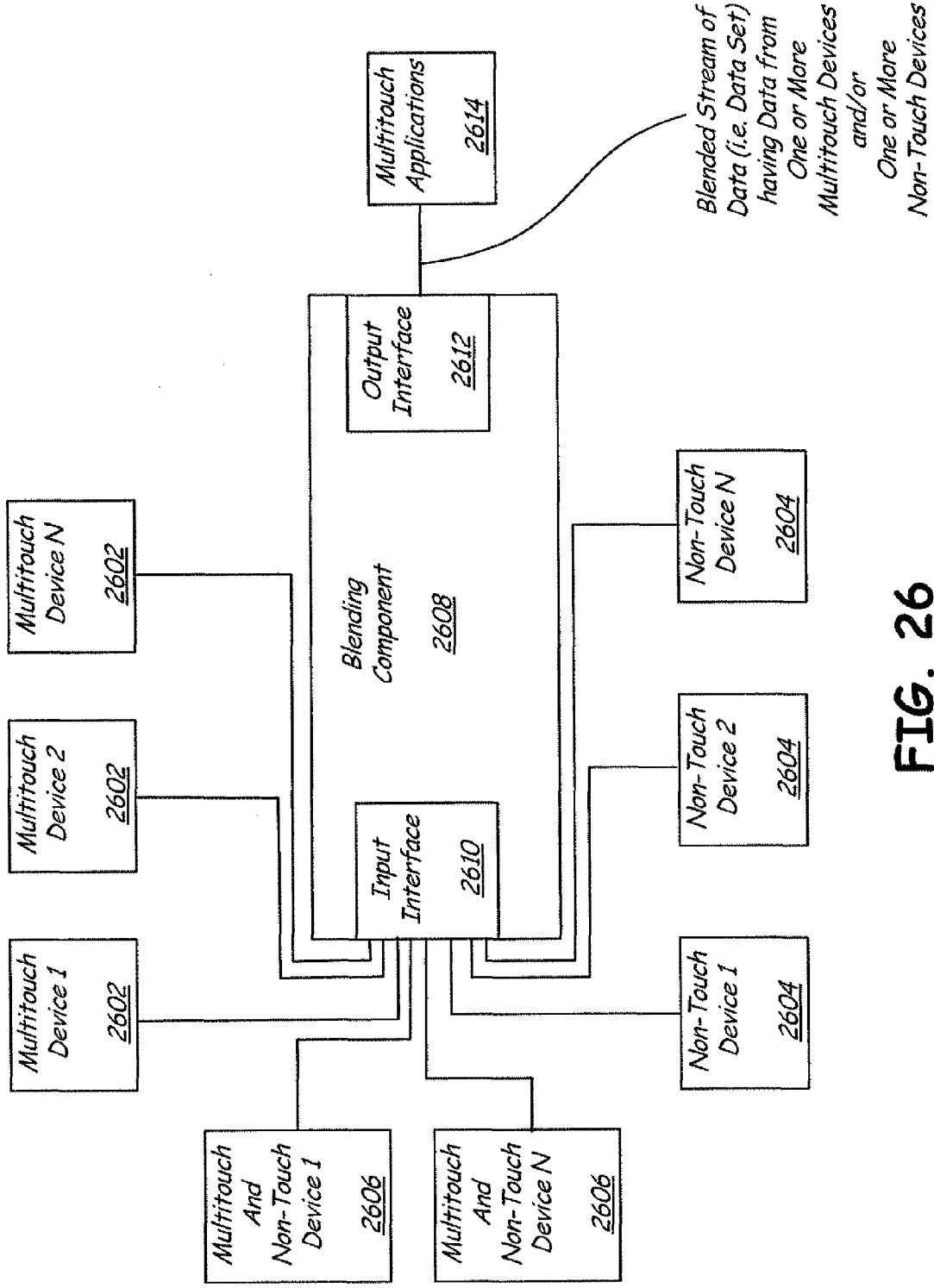
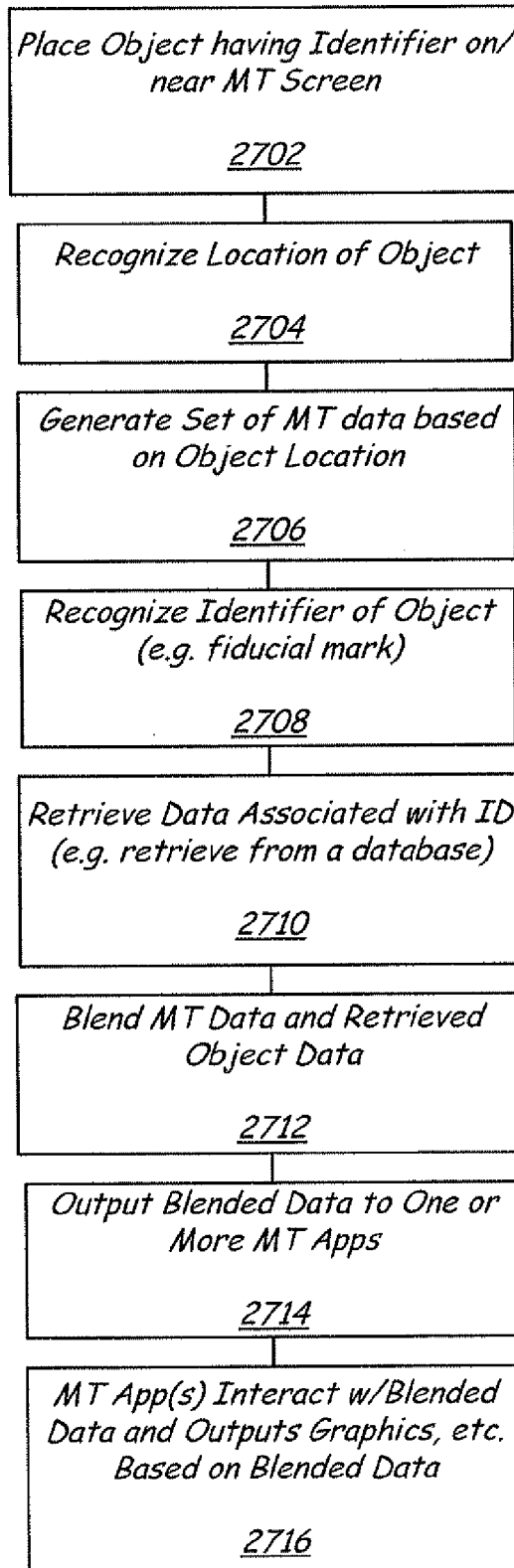

FIG. 25-6



**FIG. 26**



**FIG. 27**

**BLENDING TOUCH DATA STREAMS THAT INCLUDE TOUCH INPUT DATA**

**CROSS-REFERENCE TO RELATED APPLICATION**

[0001] The present application is based on and claims the benefit of U.S. provisional patent application Ser. No. 61/247, 964, filed Oct. 2, 2009, the content of which is hereby incorporated by reference in its entirety.

**BACKGROUND**

[0002] In multitouch systems, a user is able to provide input by touching or otherwise contacting multiple areas of a touch screen simultaneously. Multitouch systems provide for opportunities for new types of user interactions and experiences that have not been possible in single touch or non-touch systems. Some multitouch systems have included frustrated total internal reflectance systems and capacitive systems.

**SUMMARY**

[0003] Embodiments of the present invention pertain to a system that includes multiple touch input devices. Each of the touch input devices generates a set of touch data. A blending component receives the sets of touch data and generates a corresponding combined set of touch data that is outputted to a touch input application. In one embodiment, at least one of the multiple touch input devices is a multitouch input device that supports multiple simultaneous touch inputs.

[0004] These and various other features and advantages that characterize the claimed embodiments will become apparent upon reading the following detailed description and upon reviewing the associated drawings.

**BRIEF DESCRIPTION OF THE DRAWINGS**

- [0005] FIG. 1 is a block diagram of a multitouch environment.
- [0006] FIG. 2 is a perspective view of a wall type multitouch device.
- [0007] FIG. 3 is a process flow diagram illustrating the operation of a multitouch device.
- [0008] FIG. 4 is a front view of the wall type multitouch device of FIG. 2.
- [0009] FIG. 5 is a schematic diagram of a multitouch device light source.
- [0010] FIG. 6 is a back view of the wall type multitouch device of FIG. 2.
- [0011] FIG. 7 is an electrical block diagram of a multitouch device.
- [0012] FIG. 8 is a cross-sectional view of the wall type multitouch device of FIG. 2.
- [0013] FIG. 9 is a simplified perspective view of a parabolic multitouch device.
- [0014] FIG. 10 is a simplified front view of an airline gate wall multitouch device.
- [0015] FIG. 11 is a perspective view of a table type multitouch device.
- [0016] FIG. 12 is a simplified schematic diagram of a lighting scheme for a table type multitouch device.
- [0017] FIG. 13 is a cross-sectional view of the table type multitouch device of FIG. 11.
- [0018] FIG. 14 is a perspective view of a capacitive multitouch system.

[0019] FIG. 15 is a schematic diagram of a multitouch environment that incorporates multiple multitouch devices working together.

[0020] FIG. 16 is a block diagram illustrating the operation of a universal multitouch driver.

[0021] FIG. 17 is a schematic diagram of a universal multitouch driver.

[0022] FIGS. 18-1, 18-2, and 18-3 are screenshots from an Application Launcher multitouch application.

[0023] FIGS. 19-1, 19-2, 19-3, 19-4, 19-5, and 19-6 illustrate multitouch gestures that may be utilized with the multitouch applications described in this disclosure.

[0024] FIGS. 20-1, 20-2, 20-3, 20-4, and 20-5 are screenshots of a Chat and Group Collaboration multitouch application.

[0025] FIGS. 21-1 and 21-2 are screenshots of a Finger Painting multitouch application.

[0026] FIG. 22 is a screenshot of a Falling Debris multitouch application.

[0027] FIG. 23 is a screenshot of a Duck Shot multitouch application.

[0028] FIG. 24 is screenshot of a Text Messaging multitouch application.

[0029] FIGS. 25-1, 25-2, 25-3, 25-4, 25-5, and 25-6 are screenshots of a Flight Scheduling multitouch application.

[0030] FIG. 26 is a block diagram of a data blending component.

[0031] FIG. 27 is a process flow diagram illustrating the operation of a blending component.

**DETAILED DESCRIPTION**

[0032] Embodiments of the present disclosure include systems and methods that may be utilized in multitouch environments. FIG. 1 is a block diagram of one illustrative environment in which some embodiments may be incorporated. It should be noted however that FIG. 1 is for illustration purposes only and that embodiments are not limited to any particular environment. Embodiments are illustratively incorporated in any multitouch environment.

[0033] FIG. 1 shows a multitouch device 100 that is optionally communicatively coupled to a radio frequency identification reader 102, an object detection sensor 104, and a barcode reader 106. As will be described in greater detail later, these input devices illustratively collect information that is utilized in combination with multitouch information from the multitouch device. For instance, in one embodiment, such as in that shown in FIGS. 25-1 to 25-6, a multitouch device 100 is running a flight scheduling application. In that embodiment, users are illustratively able to use barcode reader 106 to scan their boarding pass and are then able to make changes to their flight plans by making selections on the screen of multitouch device 100. FIG. 1 also shows that device 100 is optionally coupled to other input devices 108. This is to illustrate that embodiments are not limited to having any particular other type of input devices connected to a multitouch device and optionally include any other type of input device.

[0034] A multitouch device driver 110 communicates with multitouch device 100 to obtain multitouch input information collected from a user. For instance, multitouch device 100 may collect input information that includes x-axis coordinates and y-axis coordinates for touch gestures. Device driver 110 obtains that information from device 100. The input information is then passed along to a universal multitouch

device driver **120**. As those skilled in the art will recognize, multitouch device drivers **110** commonly have different types of outputs. For example, the format or syntax of outputs may vary (e.g. TUIO and HID). Also for example, the outputs may have different types or amounts of information. For instance, some multitouch devices **100** only output x and y coordinates while other devices **100** output x and y coordinates along with a change in x, a change in y, a width, a height, and an acceleration. Universal multitouch device driver **120** is illustratively able to collect the outputs of many different types of device drivers **110** and convert the outputs into a standardized or universal format. The output of universal driver **120** is then transmitted or collected by one or more applications **130**. Applications **130** are illustratively multitouch applications. Several examples of multitouch applications **130** are discussed later in this description. Embodiments are not however limited to only multitouch applications and also illustratively include single touch or no touch applications.

### I. MULTITOUCH DEVICES

[0035] Embodiments of the present disclosure are illustratively practiced with any type of multitouch device. Several different types of systems and methods are able to collect multitouch information. Some common types of multitouch devices include those that detect touches utilizing capacitive screens and those that detect touches utilizing a vision based system. Some illustrative embodiments of multitouch devices are described below.

[0036] FIGS. 2, 4, 6 and 8 show a wall type multitouch device **200**. Device **200** is referred to as a wall system because its screen **202** has a relatively large form factor. For example, in one embodiment, the height **204** of screen **202** is forty-six inches, and the width **206** of screen **202** is eighty inches. Embodiments are not however limited to any particular dimensions, and embodiments illustratively include screens **202** that have any shape or size. Additionally, multiple devices **200** may be connected together and function as an even bigger wall.

[0037] Device **200** also includes a depth **208**. Depth **208** may be any value. In one embodiment, for illustrative purposes only and not by limitation, depth **208** is twenty-six inches. In at least certain embodiments of the present disclosure, depths **208** are able to be kept relatively short by utilizing multiple projectors and/or low throw projectors to display graphics on screen **202**. Embodiments may however have other configurations such as, but not limited to, systems that utilize only one projector and/or those having longer depths **208**.

[0038] FIG. 3 is a flow diagram showing one method of operating multitouch devices such as, but not limited to, device **200** in FIG. 2. At block **302**, a blanket of light is generated over the front of screen **202**. For instance, in FIG. 2, a blanket of light is generated between screen **202** and user **210**. At block **304**, an imaging camera is positioned such that it is able to detect objects illuminated by light blanket. At block **306**, graphical images are projected onto screen **202**. At block **308**, one or more users interact with the graphical images on the screen. For instance, in a flight scheduling application, a map may be displayed on the screen, and a user selects his destination by touching the corresponding portion of the screen. At block **310**, the imaging camera detects the user's interactions. This information is then used at block **312** to update the graphics on the screen. For instance, continuing with the flight scheduling application example, once a user

touches his destination, the multitouch device may show available flights going to that destination. As is indicated by arrow **313**, the process then returns to block **308**, and blocks **308**, **310**, and **312** are repeated as needed.

[0039] FIG. 4 is a schematic diagram of the front of device **200**. Device **200** includes multiple light sources **212** that generate a light blanket over the front of screen **202**. In one embodiment, light sources **212** are infrared laser diodes. Infrared light is useful in that it is not visually perceivable by human eyes so it does not interfere with graphics displayed on the screen. Embodiments are not however limited to any particular type of light sources and optionally include any type of light source.

[0040] FIG. 5 shows one example of an infrared laser diode light source **212**. In FIG. 5, the output of light source **212** is passed through a line filter **214**. Filter **214** illustratively changes the light source output such that a beam of light **216** is formed that has an angle **218** and a height **217**. Different filters **214** may be used to generate any desired angle **218** and height **217**. For instance, in one embodiment, screen **202** is curved. In such a case, filters that are used in curved portions provide smaller angles **218** than filters used for flat portions. This enables the light blanket to be kept just in front of the screen instead of diverging away from the screen. In one embodiment, flat screens or flat portions of screens use filters that have an angle **218** that is approximately one hundred and twenty degrees and a height **217** that is approximately two millimeters. Embodiments may however utilize filters providing different angles **218** and heights **217**.

[0041] Returning to FIG. 4, FIG. 4 shows that the light sources **212** at the top **220** of the screen and at the bottom **222** of the screen are each spaced apart from each other by a distance **224**, and that the light sources at the top **220** are offset from the light sources at the bottom **222** by a distance **225**. Distance **225** is optionally one half of distance **224**. This configuration, along with the "V" shaped light beam **216** shown in FIG. 5, illustratively provides a uniform blanket of light in front of screen **202**. In one particular embodiment, for illustration purposes only and not by limitation, distance **224** is twelve and a half inches and distance **225** is six and one quarter inches.

[0042] FIG. 6 is a schematic diagram of the back of device **200**. Device **200** illustratively includes multiple projectors **226**. Projectors **226** are illustratively low throw projectors. The use of multiple low throw projectors helps to reduce the depth **208** (shown in FIG. 2) of device **200** such that it has a relatively slim form factor. For instance, if only one projector was used or if non-low throw projectors were used, projectors **226** would have to be spaced further away from screen **202**, and depth **208** would have to be increased. Embodiments of the present disclosure optionally include any type of projector and any number of projectors including one. For example, a system twice as long as the one shown in FIG. 6 may have eight low throw projectors.

[0043] FIG. 6 also shows that device **200** includes an imaging camera **228**. Imaging camera **228** is not limited to any particular type of camera. The selection of camera **228** depends upon how the light blanket in front of the screen is formed. Camera **228** needs to be able to detect objects illuminated by the light blanket and needs to be selected accordingly. In one embodiment, in which infrared light is used to generate the light blanket, imaging camera **228** is either an infrared camera or is a camera fitted with an infrared filter such that camera **228** is able to image objects illuminated with



infrared light. Camera 228 optionally includes any angle of field of view, frame rate, and resolution, and the selection of the camera is based upon the size of the screen and desired sensitivity of light detection. In one particular example, camera 228 has a field of view from 56 to 75 degrees, frames rates from 60 to 120 hertz, and resolutions from 320 by 240 to 640 by 480 pixels. In some embodiments, such as in the case of a device 200 having a longer length 206, multiple cameras 228 may be used as needed.

[0044] FIG. 6 further shows that device 200 includes a control system 230 and a power source 232 for lights 212. Control system 230 illustratively runs the operations of device 200. For instance, system 230 generates the graphics that are output to the projectors and processes any computations needed by applications running on device 200. In one embodiment, system 230 is one computer (e.g. a workstation, server, personal computer, blade, etc.). The exact implementation of system 230 is not however limited to any particular type of system or group of systems. Similarly, device 200 may or may not need a power source 232 depending upon the type of light source 212.

[0045] FIG. 7 is a simplified electrical block diagram of device 200. Control system 230 operates the light power source 232 such that it controls the turning on and turning off of light sources 212. Control system receives the output of imaging cameras 228 and processes the images to determine the positions of objects illuminate by the light blanket in front of the screen. Control system 230 also generates and supplies the projectors 226 with graphics that are displayed on the device's screen.

[0046] FIG. 7 shows that device 200 is further optionally connected to other devices 234. These other devices may include an RFID reader, a barcode reader, and an object detection sensor, such as those shown in FIG. 1. Devices 234 may include any devices that are useful for applications being run on device 200. Devices 234 may also include devices that are needed for or useful for the operation of device 200. In one embodiment, devices 234 includes an additional camera that is put in front of device 200. The additional camera generates images that are used to blend the images of the multiple projectors together such that the image displayed on the screen looks as if it were generated by a single projector.

[0047] FIG. 8 is a cross-section of device 200 from the perspective of line 8-8 in FIG. 4. In one embodiment, such as in the one shown in FIG. 8, the screen of device 200 includes several components. The screen illustratively includes a piece of transparent material 236 (e.g. glass or plexiglass), a backing/screen material 237, and a light absorbing edge 238 (e.g. an acid washed edge). Backing material 237 provides a surface on which the images of projectors 226 are displayed. Material 237 is chosen such that a user on the opposite side of the screen from projectors 226 can view the images. For example, material 237 is illustratively any translucent material.

[0048] FIG. 8 shows a light blanket 240 in front of the screen. Blanket 240 illustratively has a depth 241 that extends along the entire surface of the screen of device 200 (i.e. it is a three-dimensional box having the dimensions of depth 241 by height 204 (shown in FIG. 2) by width 206 (also shown in FIG. 2)). In an embodiment, light sources 212 are positioned such that their outputs overlap the screen. For example, in one embodiment, the outputs of light sources 212 have heights (e.g. height 217 in FIG. 5) that is two millimeters, and the light sources are positioned such that the one and a half

millimeters of the height is in front of the glass, and the other half of a millimeter is directed to the light absorbing edge 238 that extends along the entire length 206 of the top 220 of the screen and of the bottom 222 of the screen (note: length 206, top 220, and bottom 222 are shown and labeled in FIG. 4). In another embodiment, light sources 212 may be positioned such that there is no overlap with the screen or may even be positioned such that there is a gap between the light blanket and the screen. Embodiments are not limited to any particular positioning of the light blanket relative to the screen.

[0049] FIG. 8 also shows imaginary lines 229 emanating from imaging camera 228 and quasi-imaginary lines 227 emanating from projectors 226. The imaging camera lines 229 represent the field of view of the camera and illustrate that the camera is able to detect illuminated objects over the entire surface of the screen. As was previously mentioned, in another embodiment, multiple cameras are used and the combined field of view of all the cameras covers the entire surface of the screen. The quasi-imaginary projector lines 227 represent the graphical images generated by the projectors and displayed on the screen. As is indicated in the figure, the projectors each cover only a portion of the screen. For instance, in a four projector embodiment, each projector generates an image that covers approximately one quarter of the screen.

[0050] FIG. 9 is a simplified schematic diagram of another embodiment of a multitouch device, device 900. Device 900 illustratively operates similar to device 200. One difference between device 900 and device 200 is that in device 900, the multitouch screen 902 and its corresponding light blanket are parabolic in shape as opposed to being rectangular boxes (i.e. the top 920 and bottom 922 of screen 902 are parabolic or curved). The parabolic or curved light blanket is illustratively generated by adjusting the dispersion angles (i.e. angle 218 in FIG. 5) of the light sources 212 and the spacing 924 between the light sources. For example, for straight or flat portions of a screen, light sources illustratively have an angle of one hundred and twenty degrees and light sources are spaced twelve and a half inches apart. For parabolic or curved portions of a screen, both the angles and the spacing between light sources are reduced (e.g. less than one hundred and twenty degrees and less than twelve and a half inches). The amount of the reduction depends on the rate of change of the curve. For instance, if the screen curves thirty degrees over a length of ten feet, the angles and the spacings will need to be less than if the screen only curves ten degrees over a length of ten feet. In an embodiment, the angles are reduced by connecting the light sources to line filters that provide the desired angle. These adjustments to the angles and the spacings illustratively help to ensure that the light blanket is located just above and follows the screen, as opposed to diverging away from the screen.

[0051] FIG. 9 also has three boxes 928. These boxes illustrate one potential placement of imaging cameras for device 900 (i.e. the boxes correspond to the centers of the fields of view of the cameras). As was previously mentioned, more or fewer imaging cameras may be used depending upon the size of the screen and the fields of view of the cameras. In one embodiment of device 900, its height is the same as the height of device 200 (e.g. forty-six inches tall) but its width 906 is three times as long (e.g. device 200's width is eighty inches and device 900's width is two hundred and forty inches). In such a case, device 900 illustratively uses the same type of projectors but requires twelve instead of four. Embodiments

of devices **200** and **900** are not however limited to any particular dimensions, number of imaging cameras, number of projectors, or shape. As will be appreciated by those skilled in the art, the techniques that have been described allow for multitouch devices to be made that have any size or shape.

**[0052]** FIG. **10** is a simplified schematic view of another embodiment of a wall type multitouch device, device **1000**. In one embodiment, device **1000** is an airline gate wall and is used at an airport. The screen of device **1000** has two portions, an upper portion **1001** and a lower portion **1002**. Device **1000** illustratively includes object detection sensors **104**. As is shown in the figure, sensors are optionally grouped into pairs of two that are aligned in the vertical direction. Sensors **104** can be used to detect the presence of a person who may wish to interact with device **1000**. In one configuration, if only the lower one of the two sensors **104** in a pair of sensors detects a person, device **1000** interprets that result as indicating that a child is present in front of its screen. Device **1000** illustratively responds by launching an application **131** on lower screen portion **1002** near where the child is detected. Application **131** can be any type of application. In one example, for illustration purposes only and not by limitation, application **131** is a game application that a child may enjoy playing with. If both of the two sensors **104** in a pair of sensors detects an object, device **1000** interprets that result as indicating that an adult is present in front of its screen. Device **1000** illustratively responds by launching an application **130** on upper screen portion **1001** near where the adult is detected. Again, application **130** can be any type of application. In one embodiment, in which device **1000** is an airline gate wall, application **130** is a flight scheduling application.

**[0053]** As is shown in FIG. **10**, device **1000** has several pairs of sensors **104**. This illustrates that device **1000** supports multiple people interacting with the device simultaneously. In the specific example shown in FIG. **10**, device **1000** has four pairs of sensors **104**. Embodiments may of course have more or fewer pairs of sensors including no sensors. FIG. **10** shows that device **1000** has a height **1004** and a width **1006**. Height **1004** and width **1006** include any values and embodiments can be made to be any desired size to support the simultaneous use by any number of people. In one embodiment, for illustration purposes only, height **1004** is ninety inches and width **1006** is between nine and eighteen feet.

**[0054]** Device **1000** further optionally has multiple barcode scanners **106** and multiple RFID readers **102**. Scanners **106** may be useful for certain applications **130**. For instance, in the case of application **130** being a flight scheduling application, barcode scanner **106** can be used to scan a boarding pass, a confirmation e-mail, etc. RFID readers **102** can similarly be used along with applications **130**. Readers **102** could for example be used to read credit card information or to read user identification information. The user identification information could be used to log into an application **130**.

**[0055]** FIGS. **11**, **12**, and **13** illustrate yet another embodiment of a multitouch device, device **1100**. In one embodiment, device **1100** is a table type multitouch device and has a smaller form factor than the devices shown in FIGS. **2**, **4**, **6**, **8**, **9**, and **10**. For instance, device **1100**'s width **206** and height **204** are illustratively each in the range of one to four feet.

**[0056]** In one embodiment, the screen **1102** of device **1100** is surrounded on all four of its sides by light sources **1112**. FIG. **12** is a simplified schematic drawing showing screen **1102** and light sources **1112** in more detail. Screen **1102** includes a transparent material **1136** (e.g. glass or plexiglass)

and many small reflectors **1137** (e.g. small pieces of aluminum or chrome) embedded and disbursed throughout material **1136**. Reflectors **1137** illustratively have random orientations such that they reflect light in all directions. In one embodiment, light source **1112** is a ribbon of light emitting diodes **1113**. In one specific example, for illustration purposes only and not by limitation, diodes **1113** are three quarter inch infrared LEDs. Embodiments are not however limited to any particular type of light source. Light source **1112** generates light (e.g. IR light) that is transmitted through transparent material **1136** and is reflected by reflectors **1137**. Light source **1112** is illustratively chosen such that light is transmitted throughout the entire volume of the screen (i.e. throughout its entire width by height by thickness).

**[0057]** FIG. **13** is a simplified cross-sectional or side view of device **1100**. As is shown in the figure, a projector **1126** projects an image onto a backing/screen material **1138** that is attached to the back of glass **1136** having embedded reflectors **1137** (shown in FIG. **12**). A user **1110** interacts with images on the screen by touching the surface of the screen. When user **1110** touches the screen, light collects or becomes concentrated at the point of contact (i.e. the area of the screen being touched). Imaging camera **1128** illustratively has a field of view that covers the entire surface of the screen and is able to detect any touches (i.e. it is able to image the concentrated areas of light). For instance, in the case of light source **1112** generating infrared light, camera **1128** is optionally an infrared camera or a camera equipped with an IR filter.

**[0058]** In FIG. **13**, device **1100** is shown as having only one projector **1126** and one imaging camera **1128**. In other embodiments, device **1100** may have multiple projectors **1126** and/or multiple imaging cameras **1128** as is needed. Additionally, multiple devices **1100** are illustratively connected together and function as a single unit. For instance, up to five devices **1100** are optionally connected together and function as a single unit.

**[0059]** The multitouch devices shown in the previous figures have been vision based multitouch systems in that they detect touches utilizing optical imaging. Embodiments of the present disclosure are not however limited to only vision based systems. Embodiments are illustratively incorporated in or practiced with any type of multitouch device. FIG. **14** illustrates another type of multitouch system, a capacitive system **1400**.

**[0060]** In the example shown in FIG. **14**, a multitouch capacitive screen overlay **1402** is positioned in front of a television or monitor **1404**. In another embodiment, the multitouch capability and display device are not separate pieces and are illustratively integrated into one unit. A control system **1406** (e.g. a computer) is communicatively coupled to television/monitor **1404** and to multitouch screen overlay **1402**. Control system **1406** generates graphical output **1411** that is transmitted to and displayed on television/monitor **1404**. A user interacts with the graphics on television/monitor **1404** by touching capacitive screen overlay **1402**. Overlay **1402** then sends multitouch output **1412** back to control system **1406** that indicates the user's touches. Control system **1406** then uses the multitouch output **1412** to update its graphics and sends the updated graphics back to television/monitor **1404**.

**[0061]** It is also worth noting that any number of multiple multitouch systems are illustratively communicatively coupled together and work to run applications. FIG. **15** illustrates one example of such an environment. The environment

in FIG. 15 has three multitouch devices, a wall type device 1510 in a living room, a table type device 1530 in the living room, and a second wall type device 1520 in a bedroom. Devices are illustratively coupled to each other through an intranet/router 1541 and are also coupled to the internet 1542.

[0062] In one embodiment, the screen 1531 of table device 1530 has multiple windows, windows 1532 and window 1533. Window 1533 illustratively includes television programming of guide information such as, but not limited to, a listing of television stations and an indication of what programs will be on the stations at different times and dates. Windows 1532 are illustratively television program windows. For example, a user may select four different programs from guide window 1533 and each of the four programs is displayed in its own window 1532. The user could then control what is being displayed on the screens of the wall type devices 1510 and 1520. For instance, a user could touch one of windows 1532 and push or flick it in the direction of one of the wall devices, and the program being displayed in the window would then be displayed on the wall device. In another embodiment, table device 1530 generates audio output for headphones and the selection of one or more of windows 1532 generates one or more channels of headphone audio output (i.e. the audio corresponding to the television program being displayed in the selected windows). Additionally, the environment shown in FIG. 15 may have personal video recording capability, and a user is able to control the recording and playing of video utilizing the multiple multitouch devices. For example, for illustration purposes only and not by limitation, a user could touch the screen of table device 1530 to pause or rewind the program being displayed on wall device 1510.

[0063] The multiple multitouch device environment in FIG. 15 is not however limited to running any particular application and is illustratively used in running any application. Other illustrative applications include making or placing phone calls, making or placing video calls using optional cameras 1512 and 1522, controlling various aspects of the home (e.g. temperature, garage door), making drawings or doodles, doing homework, shopping or ordering (e.g. ordering a pizza), surfing the internet, and playing video games.

## II. UNIVERSAL MULTITOUCH DRIVER

[0064] As was previously mentioned in reference to FIG. 1, multitouch device drivers commonly output their touch information in different formats or syntax. Their various types of outputs may also have different kinds of information. For example, one multitouch device driver may only output an x and a y coordinate of a touch, and another device driver may have x and y coordinates as well as a change in x and a change in y (i.e. dx, dy). These varying forms of multitouch output can make implementing multitouch applications difficult and/or costly. For example, if an application developer wants to make a multitouch application that can be used on multiple different types of multitouch devices, he may have to make and maintain several different versions of the same application, with each of the versions being specially tailored to accommodate for a particular device driver.

[0065] In one aspect of the present disclosure, a universal multitouch driver is provided that eliminates or reduces the need to specially tailor applications to multiple types of device drivers. The universal multitouch driver is able to receive and interpret the outputs of multiple different types of device drivers. The universal multitouch driver then converts

the output it receives into a standardized format such that regardless of the format or type of information that it receives, it consistently outputs multitouch information in the same format and having the same type of information. Consequently, multitouch application developers do not have to make or maintain multiple versions of multitouch applications to implement an application across multiple types of multitouch devices. Instead, developers only need to make applications that are able to use the multitouch information from the universal multitouch driver.

[0066] FIG. 16 is a block diagram illustrating the operation of a universal multitouch driver. At block 1602, a user interacts with a multitouch screen (e.g. the user touches the screen). At block 1604, a multitouch device driver generates touch data based upon the user interaction. As will be appreciated by those skilled in the art, this touch data can include several different parameters depending upon the device driver. Touch data commonly includes a touch identifier (e.g. touch #1, touch #2, etc.) and x-axis and y-axis coordinates that correspond to the location on the multitouch screen that was touched. Touch data may also include other types of information such as a change in the x-axis coordinate from the previously sent data (e.g. dx), a change in the y-axis coordinate from the previously sent data (e.g. dy), a width of the touch (e.g. w), a height of the touch (e.g. h), and an acceleration (e.g. m).

[0067] At block 1606, the universal multitouch driver obtains the touch data from the device driver. In one embodiment, the device driver has an application programming interface, and the universal driver communicates with that interface to retrieve the data. In another embodiment, the device driver automatically sends the data to the universal driver. Embodiments are not limited to any specific manner of obtaining the data.

[0068] At block 1607, the universal multitouch driver optionally stores the data. For instance, the universal multitouch driver optionally stores the data to a volatile (e.g. DRAM) or non-volatile (e.g. flash or hard disk drive) memory.

[0069] At block 1608, the universal multitouch driver calculates any missing parameters. As was mentioned previously, different device drivers do not always output the same types of information. One device driver may for example only output a touch identifier, an x-axis coordinate, a y-axis coordinate, a width, and a height. Universal multitouch driver optionally retrieves the data stored at block 1607 and uses the current information and the stored information to generate a full set of touch data parameters (i.e. the touch identifier, x, y, dx, dy, w, h, and m). Alternatively or in addition to calculating missing parameters, the universal multitouch driver may fill in one or more missing parameters with a default value. For instance, if the device driver does not provide a width or a height, the universal driver illustratively uses a default value for those parameters (e.g. 0 or 1).

[0070] At block 1610, the universal multitouch driver formats or packages the touch data, including any calculated or default values, into a standardized format. In one embodiment, the standardized format follows the "User Datagram Protocol" or "UDP" network protocol. In another embodiment, the standardized format follows the "Extensible Markup Language" or "XML" rules. In yet another embodiment, a universal multitouch driver formats the touch data and packages it using multiple different formats simultaneously (e.g. it packages the same touch data in both UDP and XML

simultaneously). Embodiments are not however limited to any particular standardized format.

[0071] At block 1612, the universal multitouch driver transfers the standardized touch data to one or more multitouch applications. Embodiments are not limited to any particular method of transferring the data. For instance, the universal multitouch driver may send the data to the application, or alternatively the application may retrieve the data from the universal multitouch driver. In one specific example, for illustration purposes only and not by limitation, universal multitouch driver sends UDP formatted data to the UDP port 3000 and XML formatted data to the TCP port 3333. Also, as was previously alluded to, the universal multitouch driver may optionally transfer data in multiple ways simultaneously (e.g. it sends data to both port 3000 and 3333 simultaneously).

[0072] At block 1614, the multitouch application utilizes the standardized user touch data that it received from universal multitouch driver. The process then illustratively repeats itself and returns to block 1602 where a user interacts with a multitouch screen.

[0073] FIG. 17 is a block diagram illustrating one embodiment of a universal multitouch driver 1700. Universal multitouch driver 1700 illustratively has a device driver interface 1702 that is communicatively coupled to an application programming interface 1752 of multitouch device driver 1750. In an embodiment, universal multitouch driver 1700 utilizes this connection to obtain the touch data from the device driver. Universal multitouch driver 1700 also has a processing module 1704 and a storage module 1706. Module 1704 is utilized in performing any computations, processing, or logical functions that may be required. For instance, processing module 1704 may perform calculations to determine additional parameters as was described in relation to block 1608 in FIG. 16. Storage module 1706 is utilized in performing any data storage, data management, or data retrieval functions such as, but not limited to, storing touch data to calculate change in x and change in y parameters (e.g. blocks 1607 and 1608 in FIG. 16). Universal multitouch driver then has an application interface 1708 that is communicatively coupled to an interface 1782 of one or more multitouch applications 1780. This connection is illustratively used in transferring (e.g. sending or transmitting) the standardized touch data to the multitouch applications.

[0074] The methods and the universal multitouch drivers described above illustratively help to reduce problems associated with implementing multitouch applications across multiple types of multitouch devices having various types of drivers. Instead of making and maintaining multiple versions of the same application, developers only need to make and maintain one version of any given application. It should be noted however that embodiments of the present disclosure are not limited to multitouch systems or environments having universal multitouch drivers. Embodiments are illustratively practiced without a universal multitouch driver, and applications illustratively receive touch data directly from device drivers. It should also be noted that in systems having a universal multitouch driver, the universal multitouch driver is optionally bypassable. For instance, in a situation in which the data from the device driver is already in a suitable format for an application, the data may bypass the universal multitouch driver and go directly to the application.

### III. MULTITOUCH APPLICATIONS

[0075] Embodiments of the present disclosure also illustratively include a number of multitouch applications. These

applications may be practiced in environments such as those previously discussed. The applications are however not limited to any particular environment and may also be practiced in environments different than those previously discussed.

[0076] The first application that will be discussed is illustratively an Application Launcher application. As will become more clear shortly, it is used to manage other applications on a multitouch device. FIGS. 18-1, 18-2, and 18-3 illustrate various states of Application Launcher, and FIGS. 19-1, 19-2, 19-3, 19-4, 19-5, and 19-6 illustrate multitouch gestures that may be used along with Application Launcher and the other applications disclosed herein.

[0077] FIG. 18-1 shows Application Launcher from a state in which it is only showing background graphics or wallpaper 1802 on the screen of a multitouch device. In one embodiment, graphics or wallpaper 1802 are animated. FIG. 18-2 shows Application Launcher from a state in which an application menu 1804 has been activated. FIG. 19-1 shows two alternative gestures that may be used to activate the application menu. One of the gestures includes a single touch (e.g. a tap) followed by a touch that makes a line to the right. The other illustrative activation method includes making a clockwise rotation gesture on the screen.

[0078] Application menu 1804 illustratively has multiple icons that correspond to other applications that may be ran on the multitouch device. In the example shown in FIG. 18-2, application menu 1804 includes icons corresponding to or representing six applications. They are a Chat and Group Collaboration application 1811, a Finger Painting application 1812, a Falling Debris Game application 1813, a Duck Shot Game application 1814, a Text Messaging application 1815, and a Flight Scheduler application 1816. Each of applications 1811-1816 are discussed in greater detail below. In the example shown in the figures, the applications have text based icons. However, in another embodiment, the icons are graphical icons that provide some indication of the corresponding applications (e.g. a picture of a plane for a flight scheduling application).

[0079] FIG. 18-3 shows Application Launcher from a state in which two applications are launched and displayed on the screen of a multitouch device. In the illustrative example shown in the figure, the first application that has been launched is in one window 1821 of the screen, and the second application that has been launched is in a second window 1822 of the screen. Each of the two applications was illustratively launched by tapping on the corresponding icon 1811-1816 in application menu 1804. In an embodiment, such as that shown in FIG. 18-3, multiple multitouch applications are able to be ran on one device simultaneously. Application Launcher illustratively manages and allocates system resources to enable the multiple simultaneous applications.

[0080] FIGS. 19-2, 19-3, 19-4, 19-5, and 19-6 show additional gestures that may be used in applications according to the present disclosure. FIG. 19-2 represents gestures for closing application menu 1804. The gestures are essentially the opposite of the gestures shown in FIG. 19-1 for opening or launching application menu 1804.

[0081] FIG. 19-3 represents a gesture for increasing the size of a window. A user illustratively uses two fingers to touch two spots on an object displayed on a multitouch screen and then keeps touching the screen with the fingers while moving the fingers away from each other. This gesture is illustratively able to make any window larger. For example, a user can increase the size of application windows 1821 and 1822, and

application menu **1804**. Additionally, in an embodiment, a user is able to use the gesture to magnify wallpaper or background graphics.

[0082] FIG. 19-4 represents a gesture for decreasing the size of a window or de-magnifying background graphics. A user illustratively uses two fingers to touch two spots on an object and then keeps touching the screen with the fingers while moving the fingers towards each other.

[0083] FIGS. 19-5 and 19-6 represents gestures for rotating windows or background graphics. The gesture in FIG. 19-5 corresponds to clockwise rotation, and the gesture in FIG. 19-6 corresponds to counter-clockwise rotation. As indicated in the figures, the gestures include touching two spots on the screen and moving the fingers together while making parallel lines.

[0084] FIGS. 20-1, 20-2, 20-3, 20-4, and 20-5 show several illustrative examples of graphical user interfaces (e.g. screenshots) for a multitouch Chat and Group Collaboration application. The application is illustratively launched by selecting the corresponding icon **1811** from Application Launcher application menu **1804** (shown in FIG. 18).

[0085] FIG. 20-1 shows a first user interface **2001** that is illustratively utilized to log a user into the application. The log in user interface **2001** includes background graphics **2002** and a log in window **2004**. Background graphics **2002** can include any graphics desired by the user. Background graphics **2002** may also optionally include animated graphics. Log in window **2004** is illustratively used to collect information from a user such that the application is able to identify the user. This may be useful for example for retrieving a users saved information (e.g. saved preferences, friend list, etc.) or for restricting access to the application to only certain people (e.g. paying subscribers to the service). Embodiments of log in window **2004** may have any features and collect any type of information. In the specific example shown in FIG. 20-1, log in window **2004** has a title or header **2005**, a closing button **2006**, a first side or portion **2007** that enables a user to log into the application as a guest (e.g. a person that enters another person's meeting), and a second side or portion **2008** that enables a user to log into the application as a host (e.g. a person holding a meeting that others attend). The guest portion **2007** has a guest user input field **2009** to collect identifying information (e.g. a user name or handle) from a person logging in as a guest, a label or header **2010** that describes or identifies input field **2009**, and a button **2011** to submit the user's identifying information and to log into the application as a guest. The host portion **2008** has a host user input field **2012** to collect identifying information (e.g. username, email address, handle, etc.) from a user who wishes to log in as a host, a label or header **2013** that describes or identifies input field **2012**, a second host user input field **2014** that collects authentication information (e.g. a password, PIN, etc.), a label or header **2015** that describes or identifies input field **2014**, and a button **2016** to submit the user's identifying/authentication information and to log into the application as a host.

[0086] FIG. 20-2 shows a second user interface **2020** of the Chat and Group Collaboration application. Interface **2020** is illustratively displayed once a user has submitted his identification and/or authentication information to the application through a log in window (e.g. through log in window **2004** in FIG. 20-1), and the application has successfully verified the information (e.g. that the user is a registered user). Interface **2020** include a user list window **2021**. Window **2021** has an

identification label or header **2022** that helps a user understand what window **2021** is, a closing button **2023** to close window **2021**, and multiple user identification fields **2024**. Each user identification field **2024** includes a text and/or image user identifier **2025** (e.g. a user name, a real name, a picture of the user, a handle, etc.) and a status field **2026** that indicates a status of the user (e.g. online/available or offline/not available).

[0087] FIG. 20-3 shows a third user interface **2028** of the Chat and Group Collaboration application. Interface **2028** is illustratively displayed once a user has selected (e.g. touched) one or more of the user identification fields **2024**. Upon the selection of a user, a corresponding communication window **2030** is displayed on the interface. Communication window **2030** includes an identification field or header **2031** that describes a window (e.g. it identifies a selected user) and a closing button **2032** to terminate the communication session with the selected user. Communication window **2030** further has multiple buttons, **2033**, **2034**, and **2035** that allow a user to select various methods of communicating with the selected user. Button **2033** corresponds to communicating by video. Button **2034** corresponds to communicating by voice, and button **2035** corresponds to communicating by text. One or more buttons are optionally selected to communicate with the selected user using the corresponding methods. Window **2030** further optionally includes two video portions **2036** and **2037**, and a text portion **2038**. Video portions **2036** and **2037** may be used for video communication. For example, one of the portions may show video of the selected user, and the other one of the portions may show the user's own video that is being transmitted to the selected user. Text portion **2038** may be used for communicating by text. Portion **2038** may include, for example, a series of type written messages along with identifiers that show which user generated each of the messages.

[0088] It is worth mentioning again that in an embodiment, that the Chat and Group collaboration application, as well as the rest of the applications described in this specification, have multitouch capabilities. The applications illustratively support the use of multitouch gestures such as, but not limited to, those shown in FIGS. 19-1, 19-2, 19-3, 19-4, 19-5, and 19-6. This allows for windows, backgrounds, and any object within an application to be manipulated or controlled by the multitouch gestures. For instance, windows can be increased or decreased in size or rotated utilizing multitouch gestures.

[0089] Window **2030** in FIG. 20-3 further includes a drawing button **2039** that enables users to communicate by drawing images on their multitouch screens. Upon selection of button **2039**, the user interface **2040** shown in FIG. 20-4 is illustratively displayed. Interface **2040** includes a drawing window **2042**. Window **2042** has a multitouch shared drawing area **2043**. Drawing area **2043** is a shared object in that the same image of area **2043** is displayed on the multitouch screens of each of the users logged into the application (i.e. users can see what other users draw). Window **2043** further optionally has multiple buttons **2044** that provide additional features. Buttons **2044** may include features that are useful in drawing in area **2043**. For instance, buttons **2044** may include a button to draw in area **2043** in a pencil or pen format, a button to draw in area **2043** with a paint brush format, and/or a button to draw in area **2043** with a spray paint format.

[0090] FIG. 20-5 shows another user interface **2050** that may be included with a Chat and Group collaboration application. Interface **2050** includes a map window **2052**. Map

window **2052** is illustratively shared amongst all of the users logged into the system. Each user is able to control or manipulate the map shown in the window by using multitouch gestures. For instance, users may zoom in on a location utilizing the gesture shown in FIG. **19-4**, zoom out on a location utilizing the gesture shown in FIG. **19-3**, and/or rotate the view of a location utilizing the gestures shown in FIGS. **19-5** and **19-6**. Additionally, the window **2052** itself can be resized, rotated, etc. utilizing multitouch gestures.

[**0091**] FIGS. **21-1** and **21-2** show graphical user interfaces of a multitouch Finger Painting application. The application is illustratively launched by selecting the corresponding icon **1812** from the Application Launcher application menu **1804** (shown in FIG. **18**). Interface **2101** in FIG. **21-1** shows the painting area **2104** of the user interface before anything has been painted in it, and interface **2102** shows the user interface after some squiggly lines have been painted in painting area **2104**. Painting area **2104** illustratively has background graphics that look like a painting canvas or a piece of paper. Area **2104** however may include any type of graphics (e.g. one solid color).

[**0092**] Interfaces **2101** and **2102** include a plurality of color selection buttons **2106**. A user illustratively selects one or more of the colors. The selected color is then activated, and when a user touches painting area **2104**, it paints with the selected color. Interfaces **2101** and **2102** may also have additional buttons such as, but not limited to, a clear button **2108** to erase the painting/drawing in area **2104** and/or a closing button **2109** to terminate the application.

[**0093**] FIG. **22** shows a graphical user interface **2201** of a Falling Debris multitouch game application. The application is illustratively launched by selecting the corresponding icon **1813** from the Application Launcher application menu **1804** (shown in FIG. **18**). In the game, falling debris **2202** move from the top of the interface towards the bottom of the interface. Debris **2202** have tails **2203** that represent the previous locations of the debris. The object of the game is for a user to trigger explosions **2205** to destroy the debris before they hit houses **2204**. In an embodiment, explosions **2205** are triggered by a user touching the screen (i.e. an explosion occurs where the screen is touched). Given the multitouch capabilities of the application, a user is able to touch multiple spots on interface **2201** simultaneously, thus triggering multiple simultaneous explosions **2205**.

[**0094**] FIG. **23** shows a graphical user interface **2301** of a Duck Shot multitouch game application. The application is illustratively launched by selecting the corresponding icon **1814** from the Application Launcher application menu **1804** (shown in FIG. **18**). In the game, different types of objects, such as, but not limited to ducks **2302**, fish **2303**, birds **2304**, and/or octopuses **2305** intermittently are displayed on the interface. The objects optionally include targets or bulls eyes that indicate that they are to be "shot." In one embodiment, the application is displayed on a relatively large multitouch device (e.g. 80" by 46") and a user throws bean bags at the device's multitouch screen. In another embodiment, the application is displayed on a smaller multitouch device a user "shoots" the objects by touching the objects with his fingers. Upon a successful shot, interface **2301** illustratively display points **2306** that the user is awarded. Similarly, display **2301** may display negative points or points that are deducted **2307** from the user's score upon an unsuccessful shot. Because of the multitouch capability, a user is able to shoot multiple

objects simultaneously and/or multiple users can play simultaneously with each of the users being able to shoot at the same time.

[**0095**] FIG. **24** shows a graphical user interface **2401** of a Text Messaging multitouch application. The application is illustratively launched by selecting the corresponding icon **1815** from the Application Launcher application menu **1804** (shown in FIG. **18**). The application illustratively includes two windows within its user interface. The first window **2402** is a text messaging window. In the example shown in the figure, text messaging window **2402** includes a label or header **2403**, a closing button **2404**, a phone number field **2405**, a phone number field label **2406**, a subject field **2407**, a subject field label **2408**, a message body field **2409**, a message body field label **2410**, and a button to send the message **2412**. In other implementations, text messaging window **2402** may have more or fewer fields and labels than what is shown in the figure.

[**0096**] The second window in user interface **2401** is a user input window **2411**. In the example shown in the figure, the user input window **2411** is a QWERTY keyboard that has multitouch capability (e.g. a user could touch the "Shift" key and a letter key to type the capitalized version of the letter). A user illustratively utilizes the multitouch QWERTY keyboard displayed on the screen to fill out fields **2405**, **2407**, and **2409** in the text messaging window **2402**. User input window **2411** is not however limited to only QWERTY keyboards and illustratively includes any other type of input mechanism that can collect the required information from a user.

[**0097**] As was previously mentioned, all of the windows in all of the multitouch applications discussed in this specification have multitouch capabilities such as, but not limited to, resizing and rotating windows. In the case of the Text Message application, for example, both the user input window **2411** and the text messaging window **2402** are able to be resized, rotated, moved, etc. utilizing multitouch gestures.

[**0098**] FIGS. **25-1**, **25-2**, **25-3**, **25-4**, **25-5**, and **25-6** show several graphical user interfaces of a Flight Scheduling application. The application is illustratively launched by selecting the corresponding icon **1816** from the Application Launcher application menu **1804** (shown in FIG. **18**). FIG. **25-1** shows a user interface **2501** that is illustratively the background of the application or the default interface of the application. The interface illustratively has background graphics **2502** that are displayed. Graphics **2502** are optionally animated graphics in that they move.

[**0099**] FIG. **25-2** shows a user interface **2503** that is used to gather information from a user. Interface **2503** illustratively has several windows that enable a user to provide various types of information. The ability to use multiple types of information may be more convenient to a user as opposed to requiring the user to know any one specific piece of information. A first window included within interface **2503** is a flight number window **2504**. A user illustratively is able to retrieve his flight information by inputting the flight number into flight number field **2505**. A second window is a record locator window **2507**. It has a field **2508** that enables a user to enter his record locator (e.g. a code given by the airline). A third window is a boarding pass window **2510**. It has a field **2511** that collects boarding pass information from a user. In one embodiment, the multitouch device running the application illustratively has a bar code reader, and a user is able to input his information by scanning his boarding pass. The input fields optionally each include a corresponding label, **2506**,

**2509**, and **2512**, that indicates to a user what type of information is to be entered into the fields.

**[0100]** FIG. 25-3 shows a user interface **2513**. Interface **2513** is illustratively displayed after a user has entered an identifier that enables the application to retrieve his flight information. Interface **2513** has a main portion **2514** that includes a map. In the example shown in the figure, the map is of the lower forty-eight states of the U.S. The map that is displayed in the window is optionally selected based upon the user's flight plans. For instance, if a user was flying from Texas to France, the map could show the lower forty-eight states and Europe. The map includes graphic that indicate the user's departure location **2515**, the user's destination location **2516**, the user's flight path **2517**, and if there are any intermediary lay over destinations, the map may also show those. In an embodiment, the graphics are animated (e.g. the location markers "bounce").

**[0101]** In addition to showing a graphical representation of the user's flight information, interface **2513** may also include a window **2518** that shows the user's flight information in text form. Window **2518** is shown in the figure as including the user's departure location, destination location, flight number, gate number, and date and time of the flight's departure. Window **2518** optionally includes any flight information (e.g. meal information, layover locations, flight duration, arrival time, etc.).

**[0102]** Interface **2513** also includes several buttons, a search for alternative flights button **2519**, a weather button **2520**, an information button **2521**, and a customer service agent button **2522**. FIG. 25-4 shows a window **2523** that is illustratively generated upon a user selecting the information button **2521**. Information window **2523** reports information about the user's flight. For instance, in the example shown in the figure, window **2523** states that the user's flight has been delayed because of weather, traffic, and mechanical issues. If the user's flight was on time with no issues, window **2523** could illustratively state that the flight was on schedule or on time. Window **2523** optionally includes an additional flight search button **2524** and customer service agent button **2525**.

**[0103]** FIG. 25-5 shows a customer service window **2526** that is generated upon a user selecting a customer service agent button. Window **2526** illustratively displays live, real time video of a customer service agent that can assist the user. As will be appreciated by those skilled in the art, this capability may eliminate the need to have customer service agents onsite which may reduce costs for an airline.

**[0104]** FIG. 25-6 shows an alternative flights window **2527** that is generated upon a user selecting a flight search button (e.g. button **2519** in FIG. 25-3 or button **2524** in FIG. 25-4). Window **2527** shows several flights that a user could take to get to his destination instead of his scheduled flight. Each of the different flights is illustratively positioned upon a tile or button **2528**, and a user can select one of the flights by touching the tile or button. In an embodiment, upon a user selecting one of the alternative flights, the user interface is updated such that it shows the new information instead of the information for the previously scheduled flight (e.g. it shows updated departure, destination, layover, time, gate, terminal, etc. information). Alternatively, a user may be prompted to input credit card information (e.g. though an RFID reader) to pay for any additional costs for the flight change.

**[0105]** Finally, a user is illustratively given weather information about his departure location, his destination location, or both upon selection of weather button **2520** (labeled in

FIG. 25-3). In one embodiment, a new window is generated and the information is given in text form. In another embodiment, the information is given in graphical form. For instance, the map shown in the user interface is illustratively updated to include graphics that indicate the weather (e.g. a sun, a snow flake, a rain drop, a dark cloud, etc.).

#### IV. BLENDING COMPONENTS

**[0106]** Certain embodiments of the present disclosure also include blending components. FIG. 26 is a block diagram of one embodiment of a blending component **2608**, and FIG. 27 is a process flow diagram illustrating the operation of a blending component. Blending component **2608** receives multiple data streams, combines or blends the multiple data streams into one data stream, and outputs the combined/blended data stream to one or more multitouch applications. Accordingly, blending component **2608** allows for multitouch applications **2614** to treat or view multiple input devices as one input device. In other words, blending component **2608** allows for multiple input devices to be used with an application without configuring/programming the application to use multiple input devices.

**[0107]** In the embodiment shown in FIG. 26, blending component **2608** includes an input interface **2610** and an output interface **2612**. Input interface **2610** receives data streams or data sets from one or more input devices. In FIG. 26, input interface **2610** receives multitouch data from devices **2602**, receives multitouch and non-touch data from devices **2606**, and receives non-touch data from devices **2604**.

**[0108]** Multitouch devices **2602** illustratively include any combination of multitouch devices. For instance, multitouch devices **2602** may comprise multitouch devices using different multitouch technologies (e.g. vision or capacitive), may comprise multitouch devices having different screen sizes, may comprise multitouch devices having different orientations (e.g. vertical vs. horizontal), and any other combination of multitouch devices.

**[0109]** Non-touch devices **2604** illustratively include mice, keyboards, RFID sensors, object detection sensors, barcode readers, fiducial marker recognition system, image recognition system, and any other type of input devices.

**[0110]** Multitouch and non-touch devices **2606** illustratively include devices that generate and output a combination of multitouch and non-touch data. In one embodiment, a multitouch and non-touch device **2606** has a system that recognizes an identity of an object placed on or near a multitouch screen and also recognizes its location. For example, in one embodiment, objects such as, but not limited to, blocks include fiducial marks. Device **2606** recognizes the positions of the objects/blocks and outputs the corresponding multitouch data. Device **2606** also recognizes the fiducial marks and determines the identities of the objects. For instance, a database optionally connected to blending component **2608** illustratively includes information that associates fiducial marks or other identifiers with information such as, but not limited to, a three-dimensional size, color, weight, etc. Multitouch and non-touch devices **2606** illustratively output the multitouch data and other data to the blending component input interface **2610**.

**[0111]** FIG. 27 is a process flow diagram illustrating the operation of a blending component **2608**. At block **2702**, an object having an identifier (e.g. a fiducial mark, 1D or 2D barcode, etc.) is placed on or near a multitouch screen. At block **2704**, the location of the object is identified. At block

2706, a set of multitouch data is generated based on the location of the object relative to the multitouch screen. At block 2708, the identifier on the object is recognized. At block 2710, data associated with the identifier is retrieved. At block 2712, the multitouch data from block 2706 and the retrieved object data from block 2710 is combined or blended together into one data set or data stream. At block 2714, the blended data from block 2712 is outputted/transmitted to one or more multitouch or other applications. At block 2716, the application or applications interact with the blended data and output graphics, sounds, etc. based on the blended data.

V. CONCLUSION

[0112] As has been described above, embodiments of the present disclosure include multitouch devices, drivers, and applications that may have improved or useful features over existing multitouch devices, drivers, and applications. These various embodiments are illustratively practiced individually or in combination with each other. Also, it is to be understood that even though numerous characteristics and advantages of various embodiments have been set forth in the foregoing description, together with details of the structure and function of various embodiments, this detailed description is illustrative only, and changes may be made in detail, especially in matters of structure and arrangements of parts within the principles of the present disclosure to the full extent indicated by the broad general meaning of the terms in which the appended claims are expressed.

What is claimed is:

- 1. A system comprising:
  - multiple touch input devices, each of the touch input devices generating a set of touch data;
  - a blending component that receives the sets of touch data from the multiple touch input devices, the component combining the sets of touch data into a single combined set of touch data that is outputted to a touch input application.
- 2. The system of claim 1, wherein at least one of said multiple touch input devices is a multitouch input device that supports multiple simultaneous touch inputs.
- 3. The system of claim 1, wherein at least two of the multiple touch input devices have a different size.
- 4. The system of claim 1, wherein at least two of the multiple touch input devices have a same shape.
- 5. The system of claim 1, wherein at least two of the multiple touch input devices have different shapes.
- 6. The system of claim 1, wherein at least two of the multiple touch input devices have a same orientation.

7. The system of claim 1, wherein at least two of the multiple touch input devices have different orientations.

8. A system comprising:

- at least one touch input device;
- at least one non-touch user input device;
- a component having a first interface and a second interface, the first interface receiving data from both the at least one touch input device and the at least one non-touch user input device, the second interface outputting a single data stream that is indicative of the data from both the at least one touch input device and the at least one non-touch user input device.

9. The system of claim 8, wherein the at least one non-touch user input device comprises a radio frequency identification device.

10. The system of claim 8, wherein the at least one non-touch user input device comprises a barcode scanner.

11. The system of claim 8, wherein the at least one non-touch user input device comprises an object recognition component.

12. The system of claim 8, wherein the at least one non-touch user input device comprises a mouse.

13. The system of claim 8, wherein the at least one non-touch user input device comprises a keyboard.

14. The system of claim 8, wherein the at least one non-touch user input device comprises a fiducial marker recognition system.

15. The system of claim 8, wherein the at least one non-touch user input device comprises an image recognition system.

16. A method comprising:

- receiving a first set of data from a touch input device;
- receiving a second set of data from another device;
- generating a third set of data that is representative of the first and the second sets of data; and
- outputting the third set of data to an application.

17. The method of claim 16, wherein the another device is a non-touch device.

18. The method of claim 17, wherein the another device is another touch input device.

19. The method of claim 18, wherein the touch input device and the another touch input device have different orientations.

20. The method of claim 18, wherein the touch input device and the another touch input device have different shapes.

21. The method of claim 18, wherein the touch input device and the another touch input device are both multitouch input devices.

\* \* \* \* \*