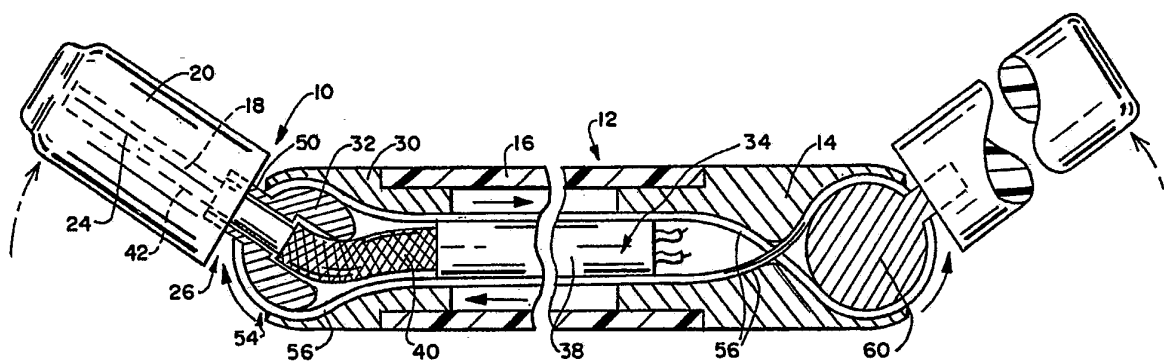




## INTERNATIONAL APPLICATION PUBLISHED UNDER THE PATENT COOPERATION TREATY (PCT)

<p>(51) International Patent Classification <sup>5</sup> : <b>A61M 37/00</b></p>	<p><b>A1</b></p>	<p>(11) International Publication Number: <b>WO 93/20886</b> (43) International Publication Date: 28 October 1993 (28.10.93)</p>
<p>(21) International Application Number: PCT/US93/03399 (22) International Filing Date: 12 April 1993 (12.04.93) (30) Priority data: 07/868,010 13 April 1992 (13.04.92) US (71) Applicant: EP TECHNOLOGIES, INC. [US/US]; 350 Potrero Avenue, Sunnyvale, CA 94086 (US). (72) Inventors: STERN, Roger, A. ; 10418 Palo Vista Road, Cupertino, CA 95014 (US). EDWARDS, Stuart, D. ; 1681 Austin Avenue, Los Altos, CA 94024 (US). JACKSON, Jerome ; 880 East Fremont Avenue, #322, Sunnyvale, CA 94087 (US).</p>		<p>(74) Agents: HOHENFELDT, Ralph, G. et al.; 633 West Wisconsin Avenue, Milwaukee, WI 53203 (US). (81) Designated States: CA, JP, European patent (AT, BE, CH, DE, DK, ES, FR, GB, GR, IE, IT, LU, MC, NL, PT, SE).  <b>Published</b> <i>With international search report.</i></p>

(54) Title: ARTICULATED SYSTEMS FOR CARDIAC ABLATION



## (57) Abstract

An improved assembly (10) for steering and orienting a functional element (20) at the distal end of a catheter tube (12) holds the functional element (20) with its major axis aligned with the axis of the catheter tube (12) for convenient steering to a tissue site. The mechanism can also pivot the functional element (20) in response to an external force to orient the major axis of the functional element generally parallel to the plane of the tissue site, without bending the catheter tube (12).

**FOR THE PURPOSES OF INFORMATION ONLY**

Codes used to identify States party to the PCT on the front pages of pamphlets publishing international applications under the PCT.

AT	Austria	FR	France	MR	Mauritania
AU	Australia	GA	Gabon	MW	Malawi
BB	Barbados	GB	United Kingdom	NL	Netherlands
BE	Belgium	GN	Guinea	NO	Norway
BF	Burkina Faso	GR	Greece	NZ	New Zealand
BG	Bulgaria	HU	Hungary	PL	Poland
BJ	Benin	IE	Ireland	PT	Portugal
BR	Brazil	IT	Italy	RO	Romania
CA	Canada	JP	Japan	RU	Russian Federation
CF	Central African Republic	KP	Democratic People's Republic of Korea	SD	Sudan
CG	Congo	KR	Republic of Korea	SE	Sweden
CH	Switzerland	KZ	Kazakhstan	SK	Slovak Republic
CI	Côte d'Ivoire	LI	Liechtenstein	SN	Senegal
CM	Cameroon	LK	Sri Lanka	SU	Soviet Union
CS	Czechoslovakia	LU	Luxembourg	TD	Chad
CZ	Czech Republic	MC	Monaco	TG	Togo
DE	Germany	MG	Madagascar	UA	Ukraine
DK	Denmark	ML	Mali	US	United States of America
ES	Spain	MN	Mongolia	VN	Viet Nam
FI	Finland				

**ARTICULATED SYSTEMS FOR CARDIAC ABLATION**

5

**Field of the Invention**

The invention generally relates to cardiac ablation catheters and systems. In a more specific sense, the invention relates to catheters that use microwave energy to ablate ventricular and atrial tachycardia foci for the treatment and control of cardiac arrhythmias.

10

**Background of the Invention**

Physicians make use of catheters today in medical procedures to gain access into interior regions of the body to ablate tissue areas. It is important for the physician to be able to accurately steer the catheter to the ablation site. Once at the site, it is important for the physician to control the emission of energy within the body used to ablate the tissue.

15

20

The need for accurate steering and precise control over the catheter is especially critical during procedures that ablate tissue within the heart. These procedures, called electrophysiology therapy,

25

are becoming increasingly more widespread for treating cardiac rhythm disturbances, called arrhythmias.

5 During these procedures, a physician steers a catheter through a main vein or artery (which is typically the femoral artery) into the interior region of the heart that is to be treated. The physician then further manipulates a steering mechanism to place the electrode carried on the distal tip of the catheter into direct contact with the tissue that is to be ablated. The physician directs radio frequency (RF) energy from the electrode tip through the tissue to an indifferent electrode to ablate the tissue and form a lesion.

15 Some clinicians have suggested the use of microwave energy for cardiac ablation. For example, Langberg U.S. Patent 4,945,915 proposes the use of a helical microwave antenna fed by a coaxial line to thermally ablate cardiac tissue. The radiation heating patterns that microwave energy propagate can, in theory at least, form lesions that are deeper than the lesions formed by the conductive heating patterns generated by conventional RF energy.

20 The ability of microwave energy to form deeper lesions also raises challenges in antenna system design. To gain all the benefits of using microwave energy, the clinician must be able to control the distribution of heating patterns propagated at the intended lesion site.

25 A microwave antenna generates an electromagnetic field that radiates in a radial plane, perpendicular to the axis of the antenna. The radial field has only minimal intensity forward of the tip of the antenna.

30 The radial field orientation of a microwave antenna is not well suited for use in conventional  
35

cardiac ablation procedures. In cardiac ablation using RF, the physician is accustomed to placing the ablation electrode tip down upon the ablation site, i.e., perpendicular to the site. Orienting a microwave antenna in this manner directs only a small percentage of the energy field upon the ablation site. Most of the energy radiates into the blood pool and serves no useful purpose. The benefits of microwave energy ablation are lost.

Ablation systems and processes using microwave energy will not find widespread clinical use, if they cannot be made and controlled to direct the major portion of the radial electromagnetic field upon the ablation site. They will also fail to find widespread use, if the microwave antenna cannot be conveniently steered and positioned to the proper orientation at desired ablation site.

#### Summary of the Invention

One aspect of the invention provides an improved assembly for steering and orienting a functional element at the distal end of a catheter tube. The functional element can be an active electrode or antenna for ablating tissue using RF, laser, and the like. The functional element can also be a passive monitoring element, like one or more mapping electrodes, MAP elements, or ultrasound electrodes.

A mechanism supports the functional element at the distal end of the catheter tube. The mechanism holds the functional element with its major axis aligned with the axis of the catheter tube for convenient steering to a tissue site. The mechanism can also pivot the functional element in response to an external force to orient the major axis of the functional element generally parallel to the plane of the tissue site, without bending the catheter tube.

In one embodiment, the pivot mechanism includes a ball and socket joint.

In a preferred embodiment, steering wires are connected to the pivot mechanism and to a remote actuator mechanism that is accessible to the user for applying the external force.

In one embodiment, the pivot mechanism is restricted to a predefined field of movement. It can also including detents for releasable retaining the pivot mechanism in one or more preselected positions.

The pivot mechanism that embodies the features of the invention is ideally suited for use in association with a microwave ablation antenna. The pivot mechanism allows the user to lay the major axis of the antenna parallel to the ablation site. In this orientation, the ablation site is exposed to the full radial field propagated by the antenna.

The pivot mechanism that embodies the features of the invention is also ideally suit for use with antenna and the like that are unidirectional. The pivot mechanism can restrict the movement of the unidirectional element to assure its proper orientation with the tissue site.

#### Brief Description of the Drawings

Fig. 1 is a perspective view of a catheter having an end assembly that embodies the features of the invention, with the end assembly holding the major axis of the associated functional element in a position axially aligned with the axis of the catheter body;

Figs. 2 and 3 are perspective views the end assembly shown in Fig. 1 with it pivoted to lay the major axis of the associated functional element against the tissue;

Fig. 4 is a sectional view of the end assem-

bly taken generally along line 4-4 in Fig. 1;

Fig. 5 is a side section view of the end assembly positioned as shown in Fig. 1;

Fig. 6 is a side section view of the end assembly positioned as shown in Figs. 2 and 3;

Figs. 7 and 8 are side section view of an embodiment of the end assembly having an associated steering mechanism;

Fig. 9 is a perspective view of the end assembly and associated steering mechanism;

Fig. 10 is side section view of an embodiment of the end assembly having an associated pivot detent mechanism;

Fig. 11 is a perspective view of an embodiment of an end assembly in association with a unidirectional antenna element; and

Fig. 12 is a section view of the unidirectional antenna element taken generally along line 12-12 in Fig. 11.

#### Description of the Preferred Embodiments

Fig. 1 shows an articulated antenna assembly 10 that embodies the features of the invention. The antenna assembly 10 is located at the distal end of a catheter 12.

The catheter 12 includes a handle 14 (shown diagrammatically in Fig. 9) and a guide body 16. The guide body 16 is flexible with its proximal end attached to the handle 14. The antenna assembly 10 is attached to the distal end of the guide body 16.

In use, the catheter provides electrophysiology therapy in the interior regions of the heart.

When used for this purpose, a physician grips the handle 14 and maneuvers the guide body 12 through a main vein or artery (which is typically the femoral arterial) into the interior region of the

heart that is to be treated. The physician then further steers the antenna assembly 10 to place it in contact with the tissue that is to be ablated. The physician directs energy to the antenna assembly 10 to ablate the tissue contacted.

In the illustrated embodiment shown in Figs. 1 to 9, the antenna assembly includes a helical microwave antenna 18 (best shown in Figs. 5 and 6). The antenna 18 is encapsulated in a potting compound 20. Preferably, the potting compound 20 includes a material (like diamond or sapphire) that has the combined characteristics of (i) a high dielectric constant; (ii) low microwave energy loss; and (iii) high thermal conductivity. The compound 20 provides a high dielectric constant for the antenna 18. By minimizing the loss of microwave energy by the antenna 18, the compound 20 also maximizes the propagation of the desired radiation heating patterns about the antenna 18. The compound 20 has high thermal conductivity that dissipates any undesirable conductive heat patterns about the antenna 18.

Further details of the compound 20 are found in copending patent application entitled "Steerable Microwave Antenna Systems For Cardiac Ablation that Minimize Tissue Damage and Blood Coagulation Due to Conductive Heating Patterns," which shares the same filing date and assignee as this application.

The microwave antenna 18 propagates an electromagnetic field 22 that radiates in a plane perpendicular to the major axis 24 of the antenna 18 (as Fig. 2 diagrammatically shows in phantom lines). There is very little field propagation forward of the distal tip of the antenna 18.

According to one aspect of the invention, the antenna assembly 10 includes means 26 for pivoting



the antenna 18 relative to the end of the guide body 12 without bending the guide body 12. The pivot means 26 orients the antenna 18 so that its major axis 24 lays generally parallel to the surface of the tissue 28 to be ablated. This orientation exposes the tissue 28 to the maximum intensity of the radial field 22 the antenna 18 propagates.

The pivot means 26 can be variously constructed. In the illustrated embodiment, the pivot means 26 takes the form of an articulated jointed assembly attached to the distal end of the guide body 12. The jointed assembly 26 includes a socket housing 30 and a ball 32 pivotally carried within the socket 30.

The antenna assembly 10 includes a coaxial cable 34 that extends within the guide body 12, into the socket housing 30, and through a passage 36 within the ball 32 for attachment to the antenna 18. The coaxial cable 34 has three, functionally different regions 38, 40, and 42.

The first region 38 constitutes the majority of the coaxial cable. It is enclosed within an outer insulation sheath 44 and runs along the guide body 16. In a preferred embodiment, the sheath 44 has an outer diameter of about .06 inch.

In the second region 40, the outer sheath 44 is absent, leaving a metallic mesh shield 46 that surrounds the core conductor wire 48. In an preferred embodiment, the mesh shield 46 has an outer diameter of about .054 inch. The second region 40 extends into the socket housing 30 and within the ball passage 36. With the removal of the relatively bulky outer sheath 44, the second region 40 is significantly more flexible than the first region 38 and accommodates movement of the ball 32 within the socket housing 30 (as Fig.

6 shows).

The third region 42 is at the distal end of the cable 34. It passes from the ball passage 36 and joins the helical antenna 18. There is no surrounding sheath 44 or shield 46 in the third region 42, leaving the core conductor 48 of the cable 34 exposed.

In a preferred embodiment, the core conductor 48 is silver coated copper having an outer diameter of about .018 inch. With the antenna 18, the third region 42 is encapsulated within the compound 20.

A shaft 50 joins the compound-encapsulated antenna 18 to the ball 32 for unified pivotal movement in a continuous multidirectional field.

The user can pivot the compound-encapsulated antenna 18 by placing its distal tip 52 against the ablation site and applying a lateral force upon the catheter guide body 12 (see Fig. 1). With the tip 52 against the tissue, the lateral force will cause the compound-encapsulated antenna 18 to pivot and lay flat against the tissue 28 at the ablation site, without otherwise bending the guide body 12.

As shown in Figs. 1 to 3, the jointed assembly 26 accommodates pivotal movement in any plane. When pivoted, the compound encapsulated antenna 18 will lay either as shown in Fig. 2 or as shown in Fig. 3, depending upon the topography of the adjacent tissue 28.

In a preferred arrangement, the jointed assembly 26 also includes a steering mechanism 54 for pivoting the ball 32 without the need to apply lateral force on the guide body 12.

The steering mechanism 54 can be variously constructed. In the illustrated embodiment, the steering mechanism 54 includes four steering wires 56

that are attached to the ball shaft 50 at 90 degree intervals. The steering wires 56 are retained in recessed grooves 58 in the ball 32.

5 As Figs. 7 to 9 shown, the steering wires 56 extend from the shaft 50, through the grooves 58 and the guide body 12 to join a remote steering lever 60 on the catheter handle 14.

10 In this arrangement, the user can move the steering lever 60 up, down, left, and right and pivot the ball 32 to move of the compound-encapsulated antenna 18 in the same direction. As before, this pivotal movement occurs without bending the catheter guide body 12.

15 Fig. 10 shows another embodiment of the jointed assembly 26. In this embodiment, the ball 32 includes detents 62 formed at preselected pivot positions. The socket housing 30 includes bearings 64 that are biased by washers 66 to nest within the detents 62. The nesting between the bearings 64 and the detents 62 retains the ball 32 in a series of pre-  
20 defined pivot positions. Additional pivot force upon the ball 32 releases the nested bearings 64 and detents 62. In this way, the user can pivot the compound-encapsulated antenna 18 within a range of pre-  
25 lected positions.

Fig. 11 shows another embodiment of a steerable antenna assembly 10' that embodies the features of the invention. The assembly in Fig. 11 includes a unidirectional microwave antenna 18'.

30 The unidirectional antenna 18' comprises a sandwich of three layers that are encapsulated in the compound 20. The first layer 68 comprises the core conductor 48 of the coaxial cable 34 (i.e., its third region 42). The second layer 70 is a dielectric material,  
35 called the dielectric plane. The third layer 72

is an energy conducting ground plane.

As Figs. 11 and 12 show, the antenna 18' propagates an electromagnetic field 22' that radiates in a single direction from the major axis 24 of the core conductor 48. There will be little, if any, field emission radially from the ground plane 72, as well as forward of the tip 52 of the antenna 18'.

Preferable, the antenna assembly 10' also includes a unidirectional pivot mechanism 74 for assuring that the antenna 18' is properly oriented with respect to the ablation site. In the illustrated embodiment, the unidirectional pivot mechanism 74 includes a jointed assembly comprising a socket housing 76 and a ball 78 like that previously described. However, unlike the fully articulated jointed assembly 26 shown in Figs. 1 to 3, the jointed 74 assembly in Fig. 11 is restricted to movement in a single range of positions.

In Fig. 11, the shaft 80 of the ball 78 is retained within a partial slot 82. The partial slot 82 allows pivotal movement of the ball 78 within the socket housing 76 only in a plane that will orient the unidirectional antenna 18' upon the tissue with its conductor core 48 facing the tissue. This aims the unidirectional field of the antenna 18' solely at the ablation site. Because all the power supplied to the antenna 18' is directed in a single direction, the power applied to the tissue is effectively doubled, when compared to an omnidirectional antenna 18, like that shown in Figs. 5 and 6. Furthermore, the unidirectional antenna 18' minimizes the exposure of the surrounding blood pool to the electromagnetic field, because the dielectric plane 70 blocks propagation of the field radially from the ground conductor layer 72. Undesired effects of blood heating, like coagulation,

are thereby minimized.

It should be appreciated that other microwave antenna structures (for example, an omnidirectional whip antenna) can be similarly attached to a pivot assembly at the end of a catheter to achieve the benefits of the invention.

The inventions provide a steerable microwave antenna assembly that maximizes the propagation of radiation heating patterns for deep lesion formation.

The inventions are also applicable for supporting any functional element at the distal end of the catheter body 12. For example, instead of supporting a microwave antenna 18, the joint assembly can support other active elements or electrodes for tissue ablation using RF, laser, and the like. The joint assembly can also support passive monitoring elements, like one or more mapping electrodes, MAP elements, or ultrasound electrodes.

Whatever the particular function of the distal element may be, the joint assembly holds the functional element with its major axis aligned with the major axis of the catheter body 12 for convenient steering to the tissue site. The joint assembly then pivots the functional element in response to an external force to orient its major axis generally parallel to the plane of the tissue site without bending the catheter body 12.

Various features and benefits of the inventions are set forth in the following claims.

The Claims

1. An end assembly attachable to the distal end of a catheter tube comprising  
a functional element having a major axis,  
and

5 means for supporting the functional element at the distal end of the catheter tube and including means for holding the functional element with its major axis aligned with the axis of the catheter tube for steering to a tissue site and for pivoting the  
10 functional element in response to an external force to orient the major axis of the functional element generally parallel to the plane of the tissue site without bending the catheter tube.

2. An assembly according to claim 1 wherein the pivot means includes a ball and socket joint.

3. An assembly according to claim 1 and further including means connected to the pivot means and to a remote actuator mechanism accessible to the user for applying the external force.

4. An assembly according to claim 1 and further including means for restricting the pivot means to a predefined field of movement.

5. An assembly according to claim 1 and further including means for releasable retaining the pivot means in at least one preselected position.

6. An assembly according to claim 1 wherein the functional element is capable of ablating tissue.

7. An assembly according to claim 6 wherein the functional element is a microwave antenna.

8. An assembly according to claim 6

wherein the functional element is a helical microwave antenna.

9. An end assembly attachable to the distal end of a catheter tube comprising

a socket housing joined to the distal end of the catheter tube,

5 a ball element carried in the socket housing for pivotal movement within it, and

a functional element attached to the ball element for unified pivotal movement with it at the distal end of the catheter.

10. An assembly according to claim 9

and further including wire means for conveying energy through the catheter tube to the functional element, and

5 wherein the ball element includes an interior passage for accommodating the wire means from the catheter tube to the attached functional element.

11. An assembly according to claim 9

and further including means on the ball element and the socket housing for releasable retaining the ball element in at least one preselected position.

12. An assembly according to claim 11

5 wherein the retaining means includes at least one detent on one of the ball element and the socket housing and at least one spring biased bearing element on the other one of the ball element and the socket housing that releasable nests within the detent when the ball element assumes the preselected position.

13. An assembly according to claim 9

5 and further including steering means connected to the ball element and to a remote actuator mechanism accessible to the user for applying an external force to pivot the ball element.

14. An assembly according to claim 9 wherein the steering means includes at least one steering wire attached to the ball element and the remote actuator mechanism.

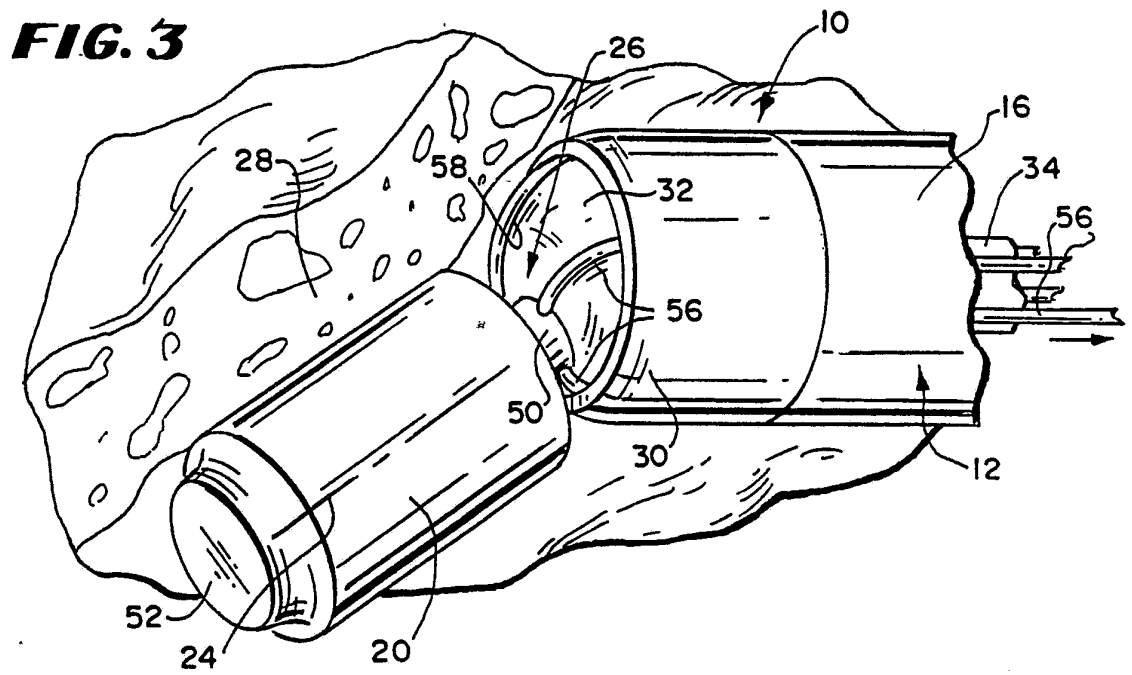
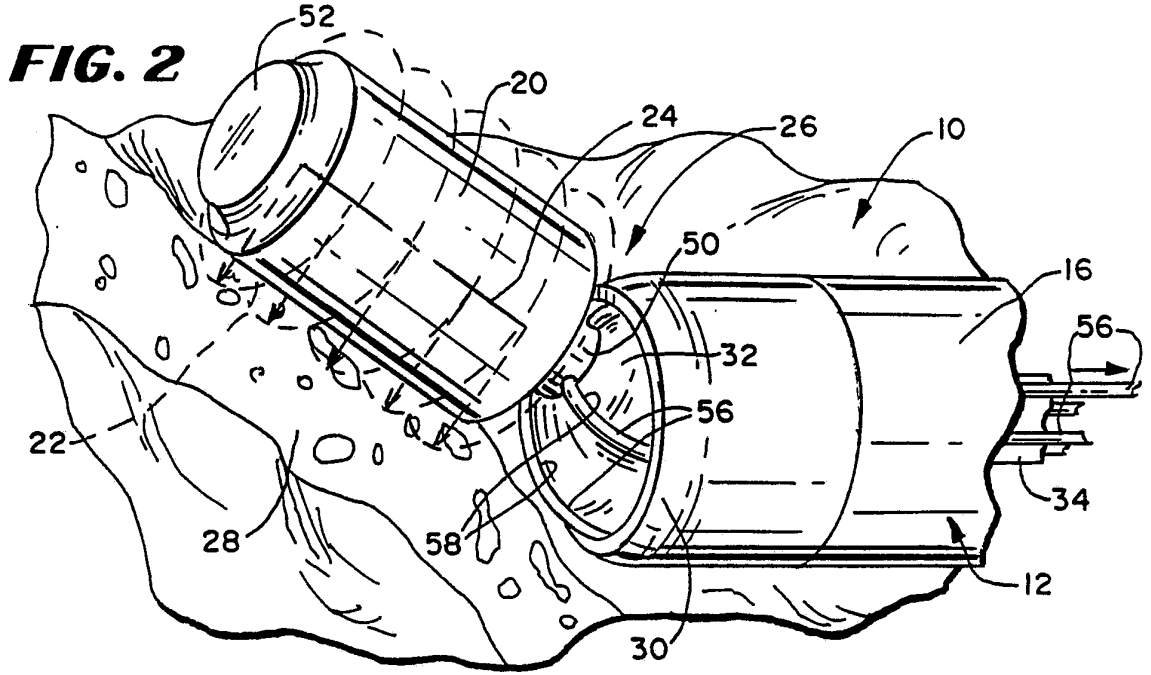
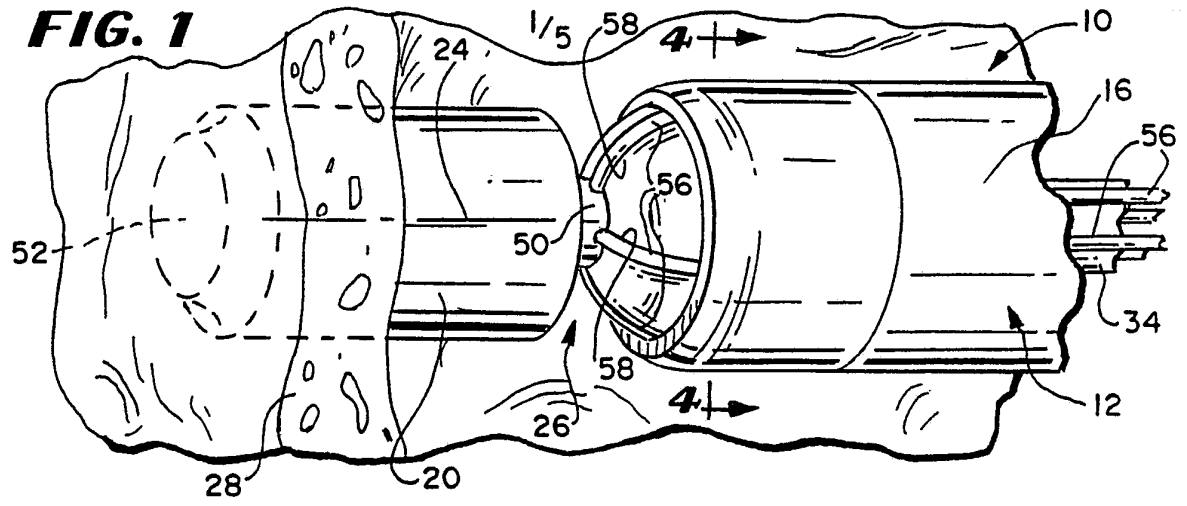
15. An assembly according to claim 9 and further including means for restricting the range of pivotal movement of the ball element within the socket housing.

16. An assembly according to claim 9 wherein the functional element is capable of ablating tissue.

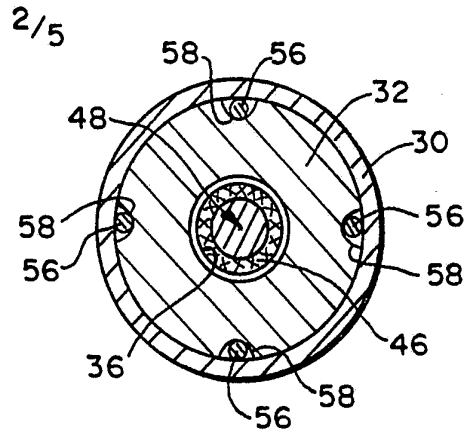
17. An assembly according to claim 16 wherein the functional element is a microwave antenna.

18. An assembly according to claim 17 wherein the functional element is a helical microwave antenna.

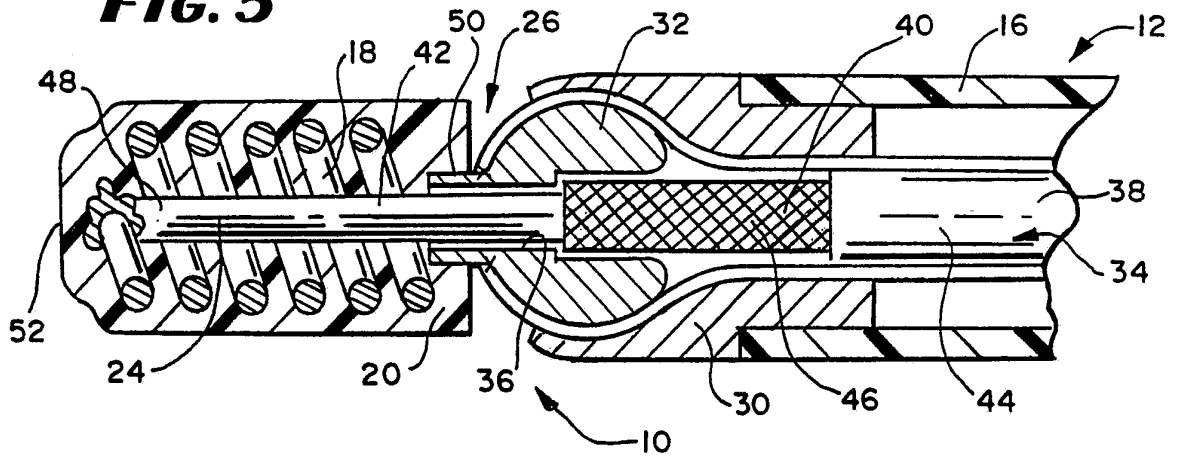




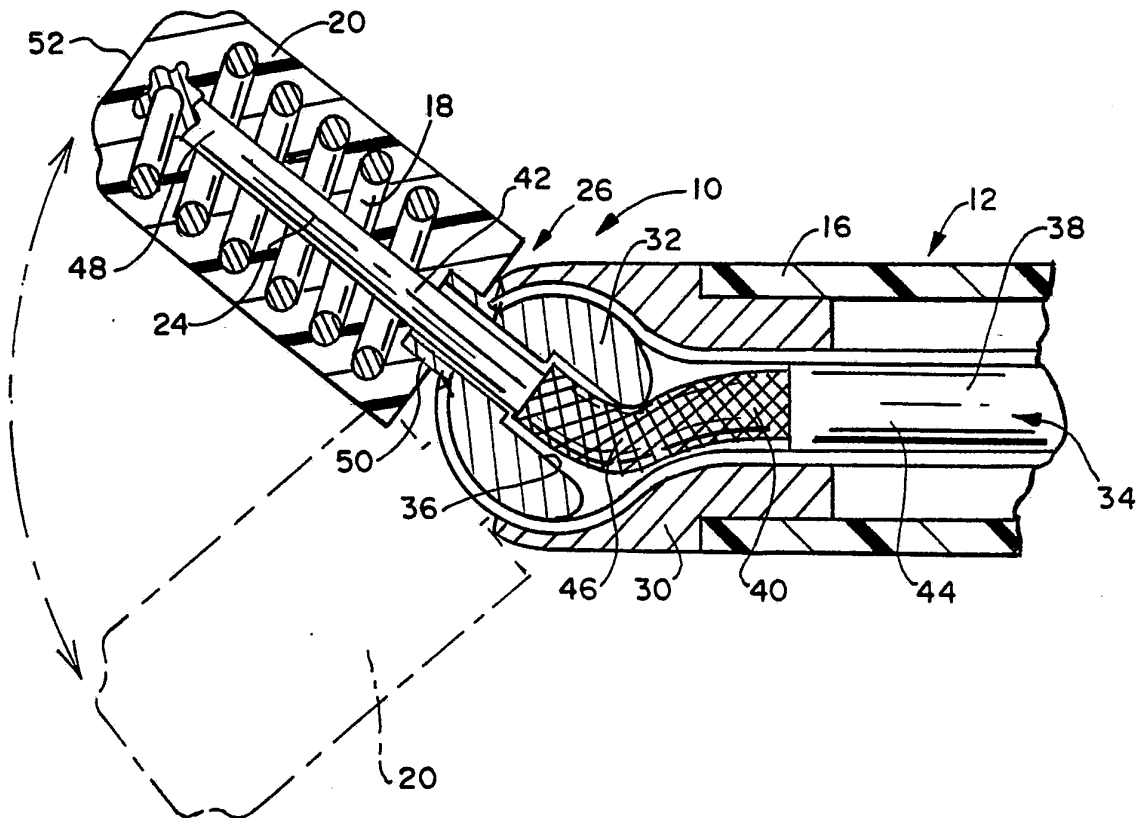
**FIG. 4**



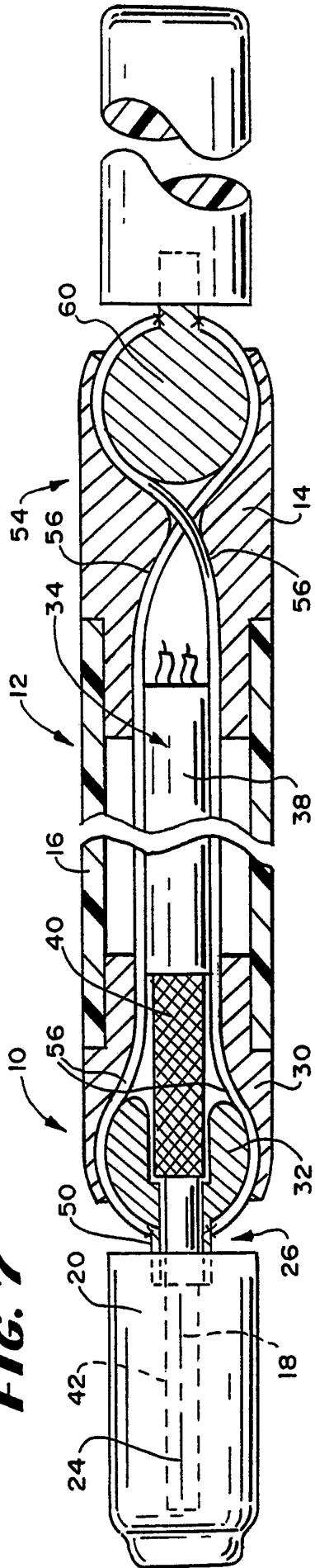
**FIG. 5**



**FIG. 6**

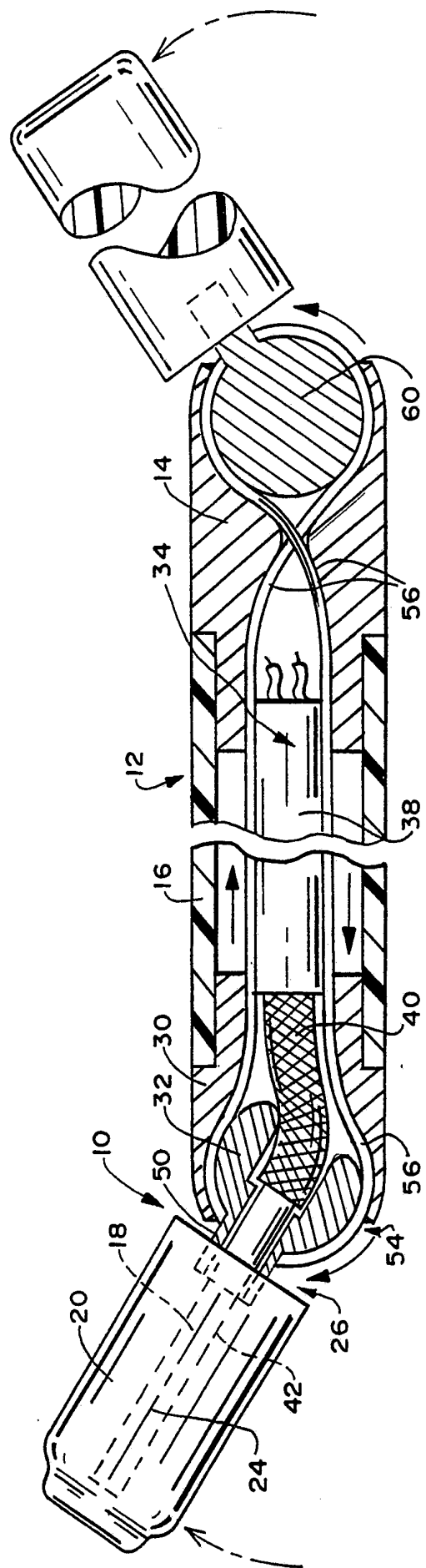


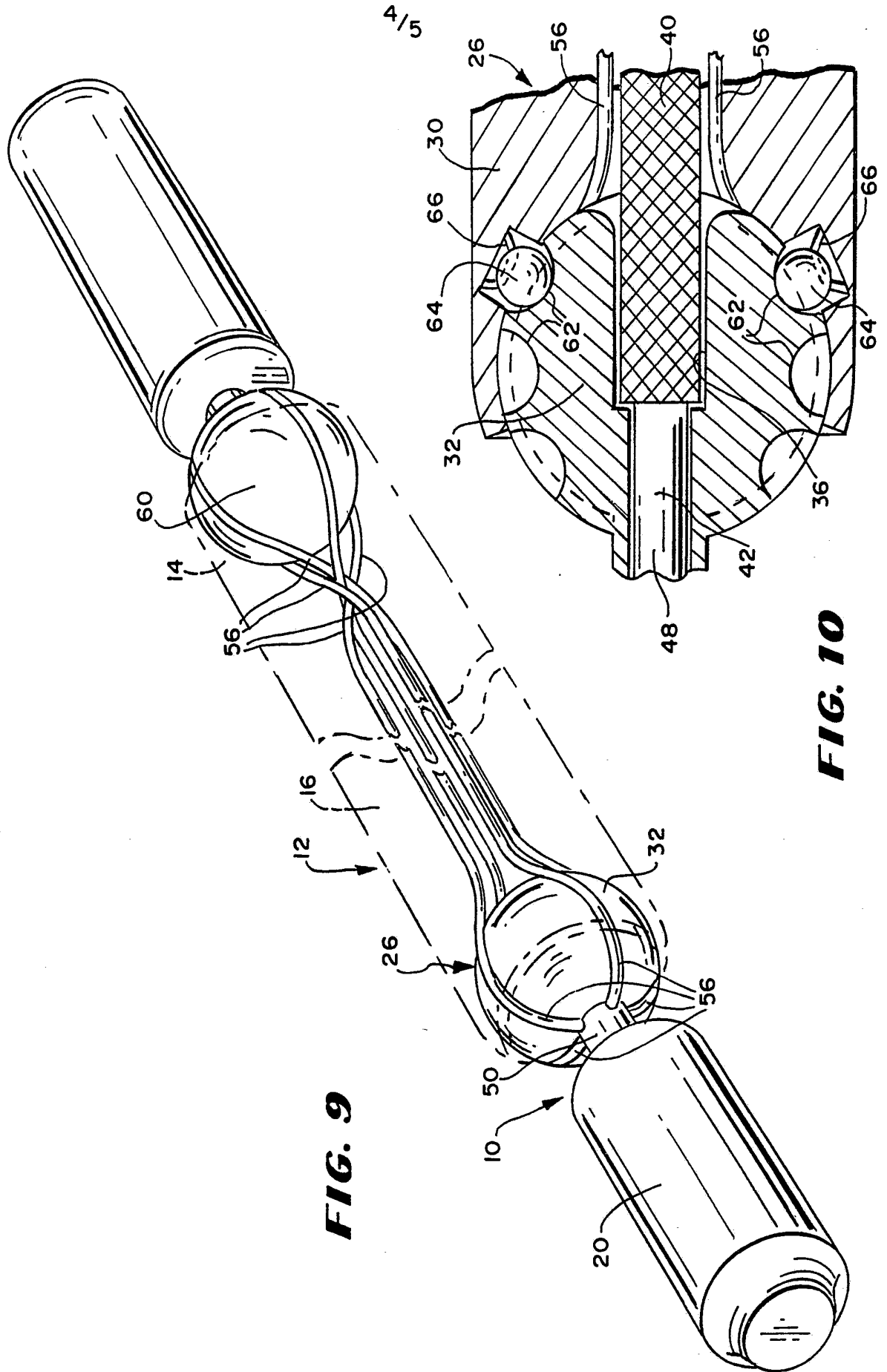
**FIG. 7**



3/5

**FIG. 8**



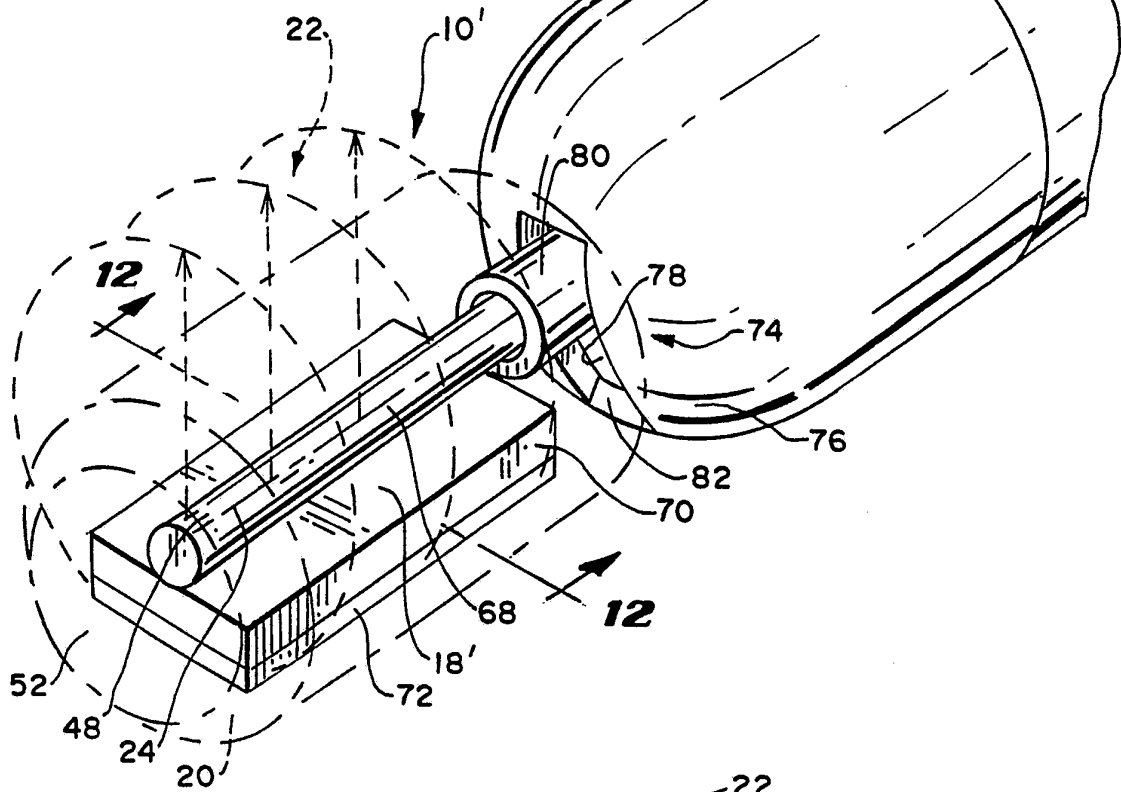


**FIG. 9**

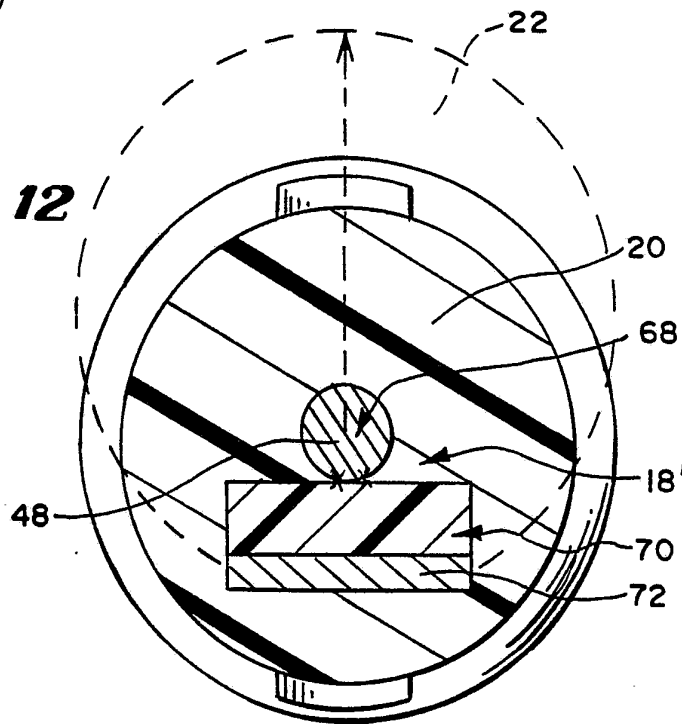
**FIG. 10**

5/5

**FIG. 11**



**FIG. 12**



INTERNATIONAL SEARCH REPORT

International application No.  
PCT/US93/03399

**A. CLASSIFICATION OF SUBJECT MATTER**  
 IPC(5) :A61M 37/00  
 US CL :606/33  
 According to International Patent Classification (IPC) or to both national classification and IPC

**B. FIELDS SEARCHED**  
 Minimum documentation searched (classification system followed by classification symbols)  
 U.S. : 606/33; 604/264,95;128/784,785,786;403/90

Documentation searched other than minimum documentation to the extent that such documents are included in the fields searched

Electronic data base consulted during the international search (name of data base and, where practicable, search terms used)

**C. DOCUMENTS CONSIDERED TO BE RELEVANT**

Category*	Citation of document, with indication, where appropriate, of the relevant passages	Relevant to claim No.
X, P Y	US,A, 5,108,368 (Hammerslag) 28 April 1992 See entire document.	1-5,9,11 <u>13-15</u> 1-18
Y	US,A, 4,945,912 (Langberg) 07 August 1990 See entire document.	1-11,13-18
Y	US,A, 4,979,948 (Geddes) 25 December 1990 See entire document.	1-11,13-18
Y, P	US,A 3,691,788 (Mazziotti) 19 September 1992 See entire document.	12
A	US,A, 3,665,928 (Del Guerico) 30 May 1972 See entire document.	1-18

Further documents are listed in the continuation of Box C.  See patent family annex.

* Special categories of cited documents:	"T" later document published after the international filing date or priority date and not in conflict with the application but cited to understand the principle or theory underlying the invention
"A" document defining the general state of the art which is not considered to be part of particular relevance	"X" document of particular relevance; the claimed invention cannot be considered novel or cannot be considered to involve an inventive step when the document is taken alone
"E" earlier document published on or after the international filing date	"Y" document of particular relevance; the claimed invention cannot be considered to involve an inventive step when the document is combined with one or more other such documents, such combination being obvious to a person skilled in the art
"L" document which may throw doubts on priority claim(s) or which is cited to establish the publication date of another citation or other special reason (as specified)	"&" document member of the same patent family
"O" document referring to an oral disclosure, use, exhibition or other means	
"P" document published prior to the international filing date but later than the priority date claimed	

Date of the actual completion of the international search 24 JUNE 1993	Date of mailing of the international search report 29 JUL 1993
---	---

Name and mailing address of the ISA/US Commissioner of Patents and Trademarks Box PCT Washington, D.C. 20231 Facsimile No. NOT APPLICABLE	Authorized officer PETER A. ASCHENBRENNER Telephone No. (703) 308-0858
---	--

## INTERNATIONAL SEARCH REPORT

International application No.  
PCT/US93/03399

C (Continuation). DOCUMENTS CONSIDERED TO BE RELEVANT		
Category*	Citation of document, with indication, where appropriate, of the relevant passages	Relevant to claim No.
A	US,A, 3,957,241 (Morris) 18 May 1976 See entire document.	1-18
A	US,A, 3,433,510 (Hulterstrom) 18 March 1969 See entire document.	1-18
A	US,A, 3,674,014 (Tillander) 04 July 1972 See entire document.	1-18
A	US,A, 4,154,246 (LeVeen) 15 May 1979 See entire document.	1-18
A	US,A, 3,841,769 (Bowerman) 15 October 1979 See entire document.	1-18