



US 20040143392A1

(19) **United States**

(12) **Patent Application Publication**
Kilfeather et al.

(10) **Pub. No.: US 2004/0143392 A1**

(43) **Pub. Date: Jul. 22, 2004**

(54) **SYSTEM AND METHOD FOR FAST ACQUISITION REPORTING USING COMMUNICATION SATELLITE RANGE MEASUREMENT**

Publication Classification

(51) **Int. Cl.7** G01C 21/26

(52) **U.S. Cl.** 701/213

(75) **Inventors: James B. Kilfeather**, Purcellville, VA (US); **Mark C. Sullivan**, Annandale, VA (US)

(57) **ABSTRACT**

A geographic tracking system with minimal power and size required at the mobile terminal collects observation data at the mobile terminal, forwards the data to a processor, which calculates the position. The mobile terminal needs only to gather a few milliseconds of observation data, and to relay this observation data to the processor. The range from the satellite (or other airborne transponder) to the terminal is determined using the known positions of an interrogating transmitter and a satellite, and a known terminal delay between the received signal and the transmission of the return signal, and the round trip time. An arc of locations is determined by computing an intersection of a sphere centered at the satellite having a radius given by the calculated range with a model of the Earth's surface. The candidate points are considered and refined using code phase measurements from a set of GPS satellites. The candidate point having the lowest residuals or expected to measured code phases is chosen as the location of the mobile terminal. The measurements can be refined to account for various sources of error including measurement bias, relative motion and timing errors.

Correspondence Address:
Law Office of Duane S. Kobayashi
1325 Murray Downs Way
Reston, VA 20194 (US)

(73) **Assignee: SkyBitz, Inc.**

(21) **Appl. No.: 10/754,492**

(22) **Filed: Jan. 12, 2004**

Related U.S. Application Data

(63) Continuation of application No. 10/191,288, filed on Jul. 10, 2002, now Pat. No. 6,725,158, which is a continuation of application No. 09/984,069, filed on Oct. 26, 2001, now Pat. No. 6,480,788, which is a continuation-in-part of application No. 09/351,852, filed on Jul. 12, 1999, now Pat. No. 6,243,648.

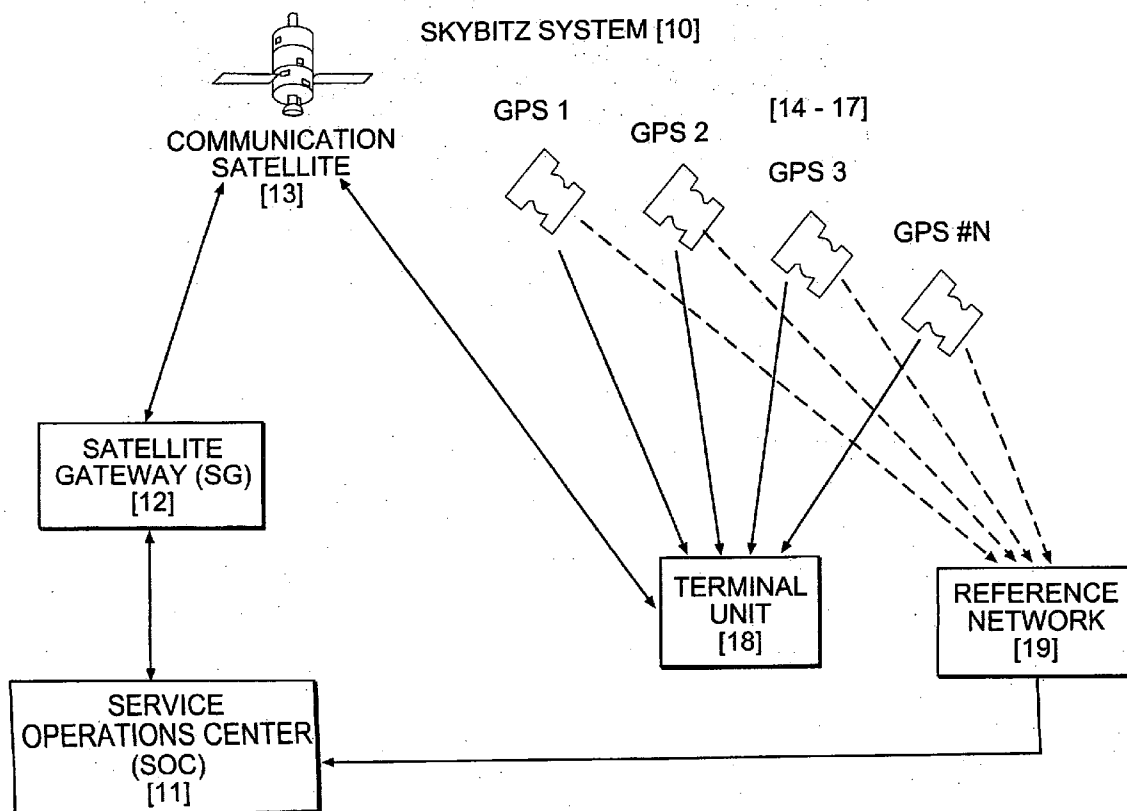

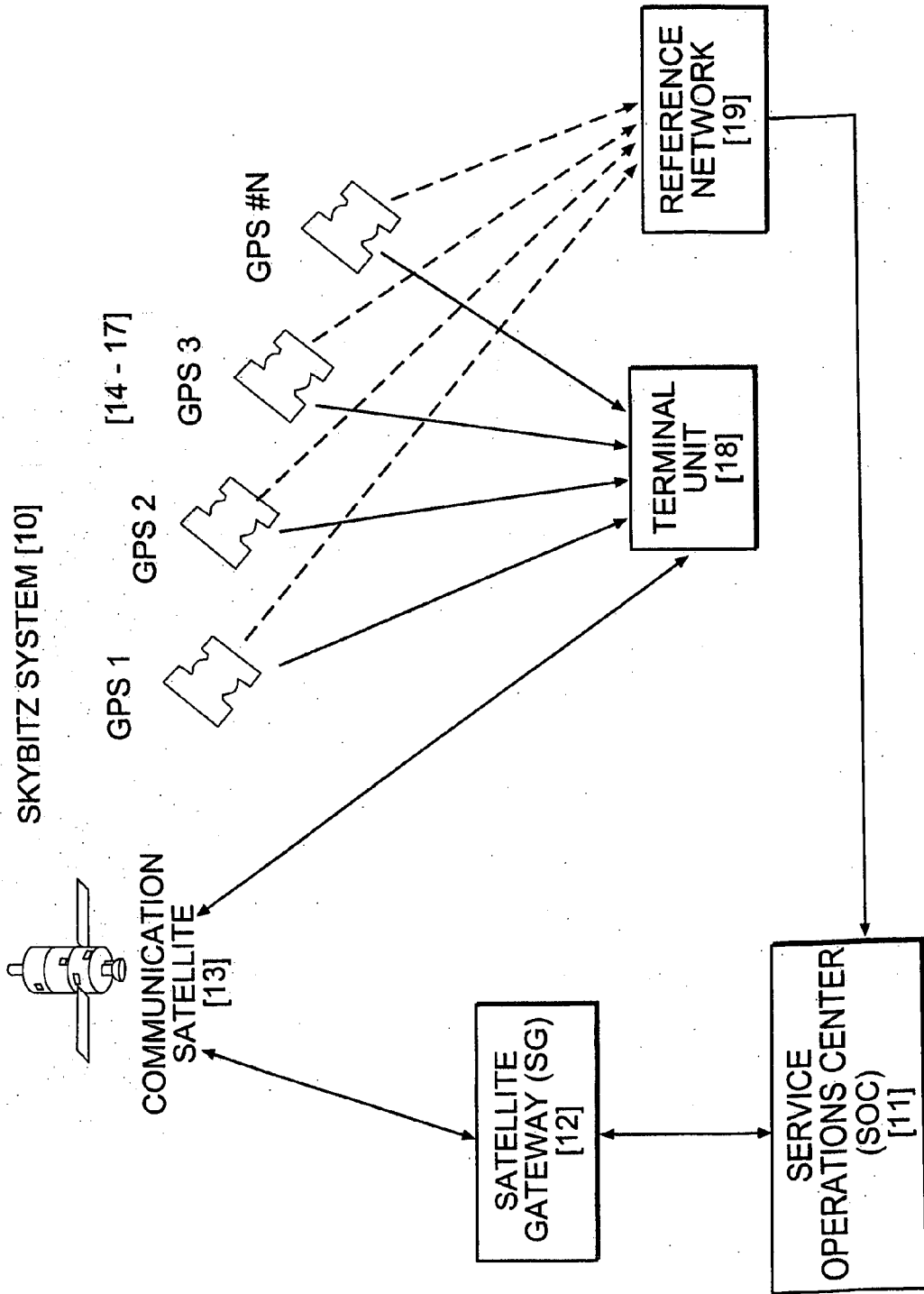
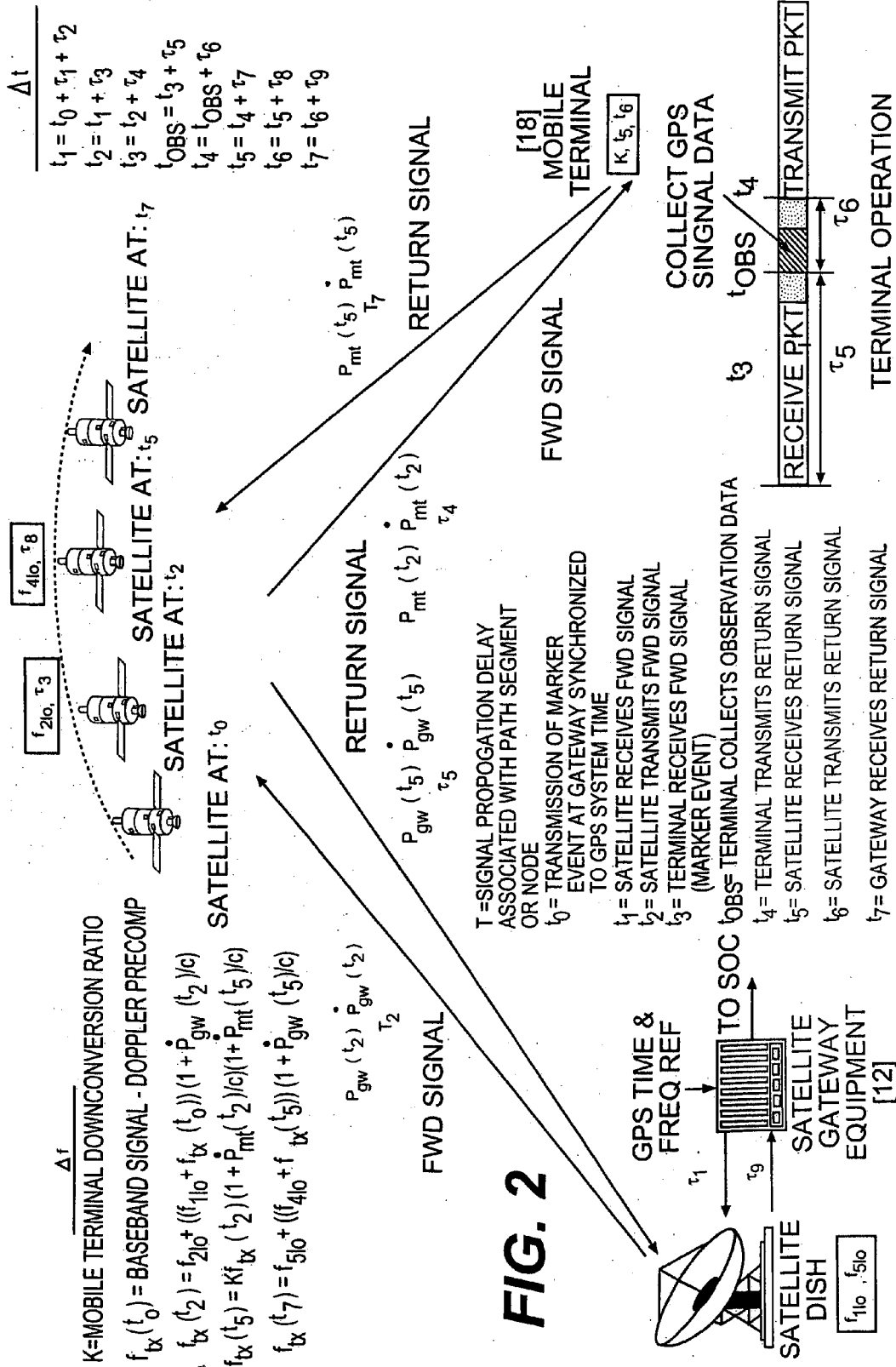

FIG. 1



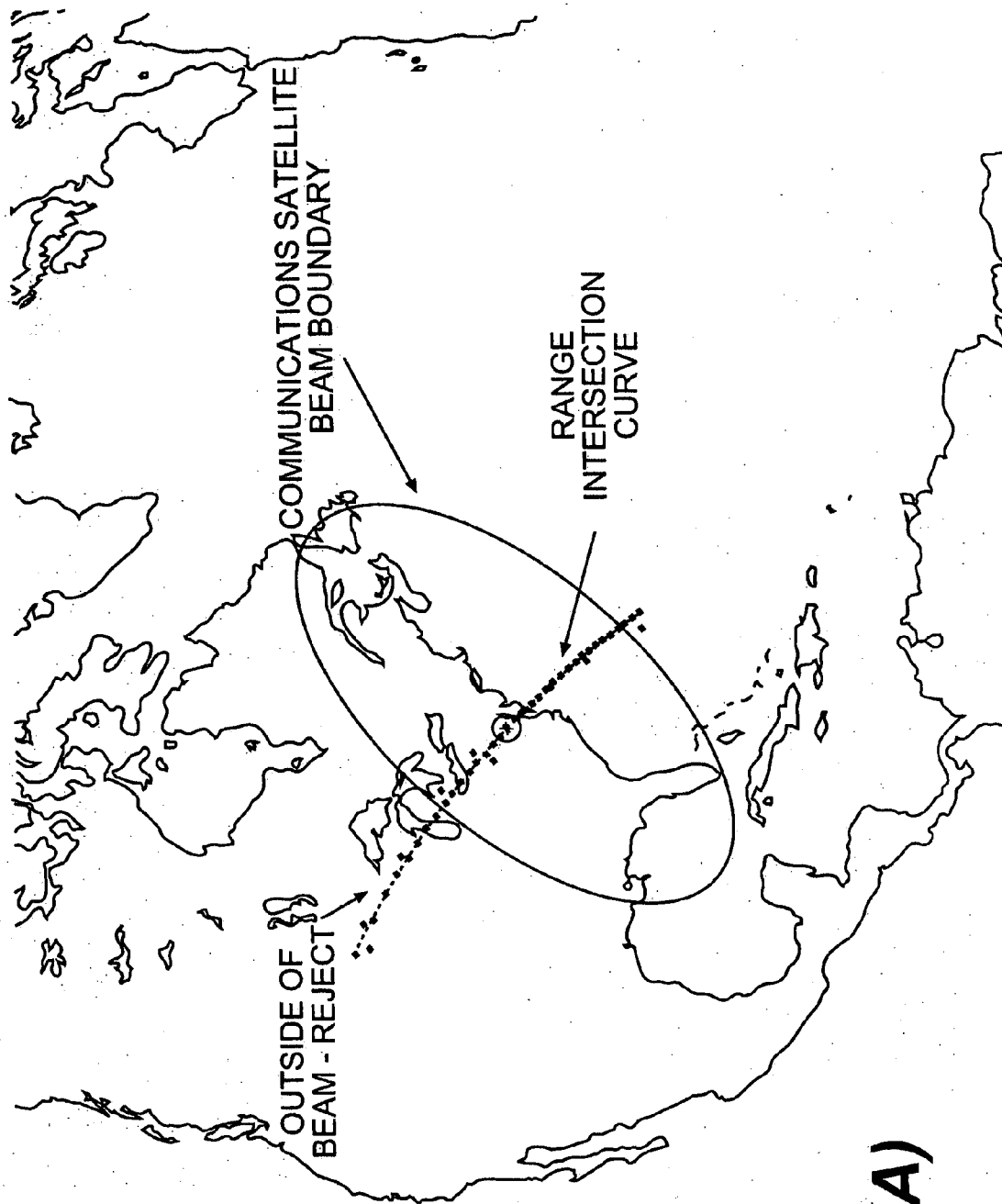

FIG.3 (A)

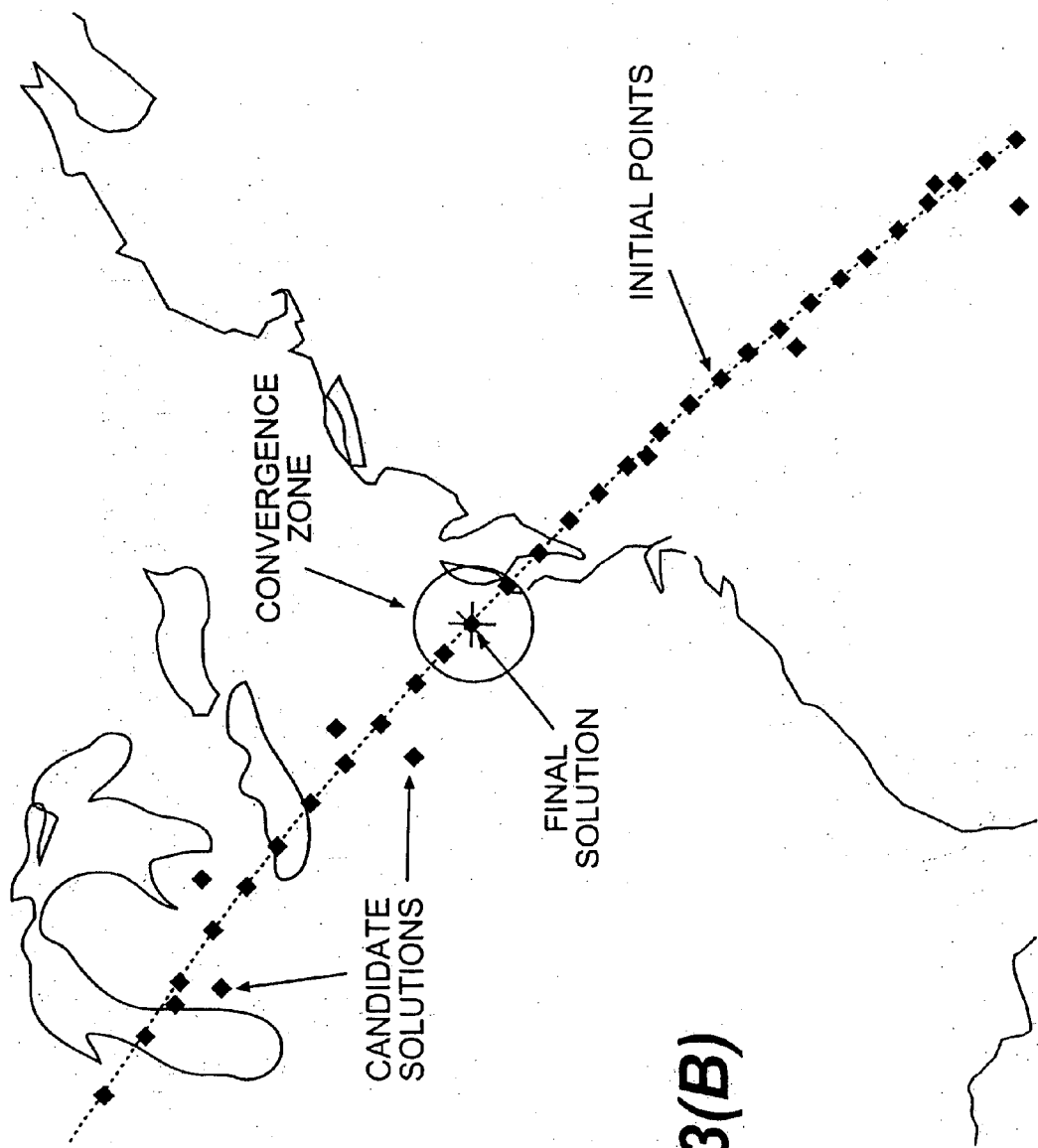

FIG. 3(B)

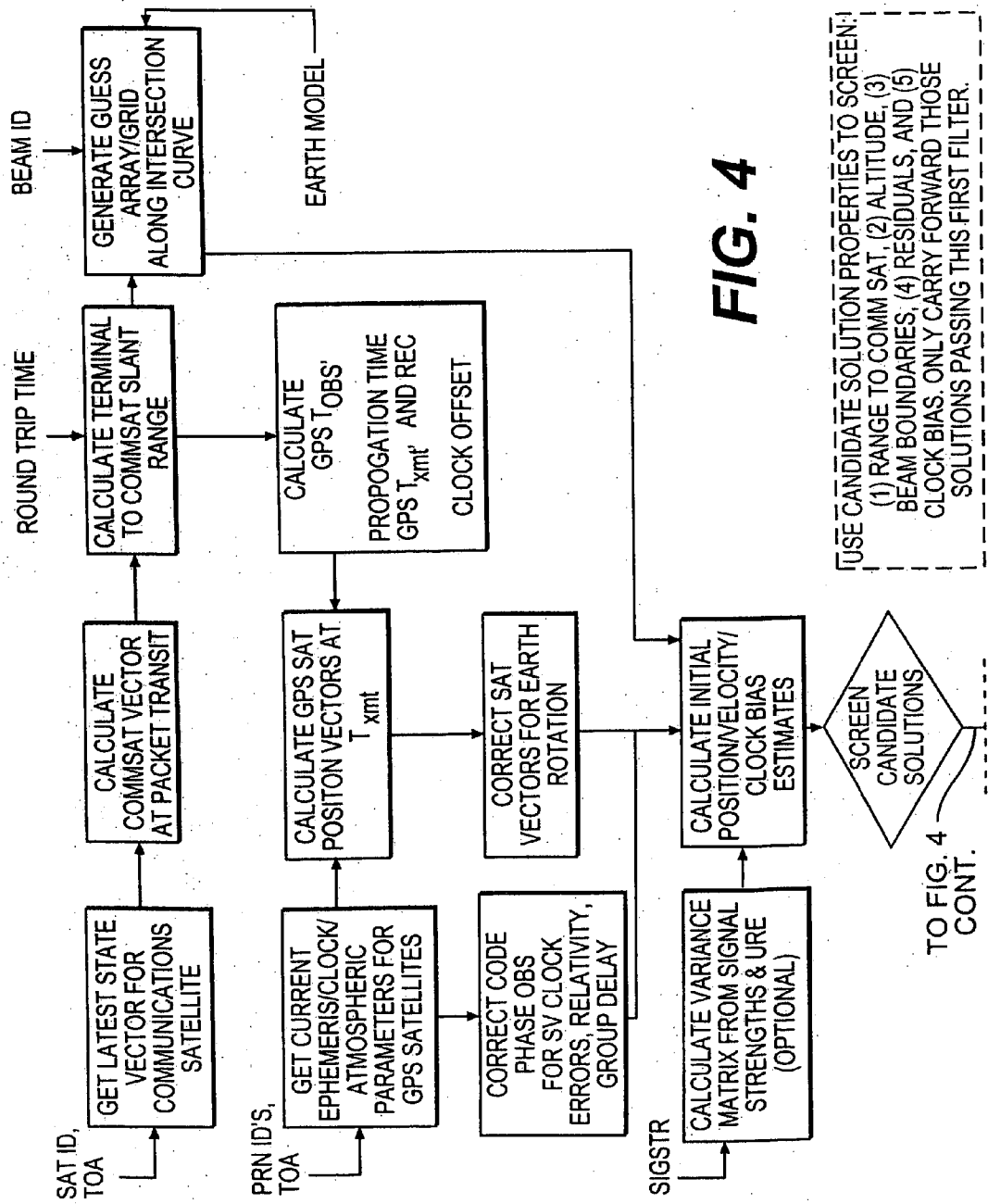

FIG. 4

USE CANDIDATE SOLUTION PROPERTIES TO SCREEN:
 (1) RANGE TO COMM SAT, (2) ALTITUDE, (3) BEAM BOUNDARIES, (4) RESIDUALS, AND (5) CLOCK BIAS. ONLY CARRY FORWARD THOSE SOLUTIONS PASSING THIS FIRST FILTER.

TO FIG. 4 CONT.

PARAMETERS	
1	SATELLITE ID
2	BEAM ID
3	GATEWAY ID
4	CHANNEL ID
5	NETWORK
	CAROUSEL VER
6	MT ADDRESS
7	PACKET TIME OF ARRIVAL
	YEAR
	MONTH
	DAY
	HOUR
	MIN
	SEC
8	ROUND TRIP TIME
9	PRN ID #1
	PRN ID #2
	PRN ID #3
	PRN ID #N
10	CODE PHASE #1
	CODE PHASE #2
	CODE PHASE #3
	CODE PHASE #N
11	SIGNAL STR #1
	SIGNAL STR #2
	SIGNAL STR #3
	SIGNAL STR #N
12	STATUS WORD

FIG. 4 CONT.

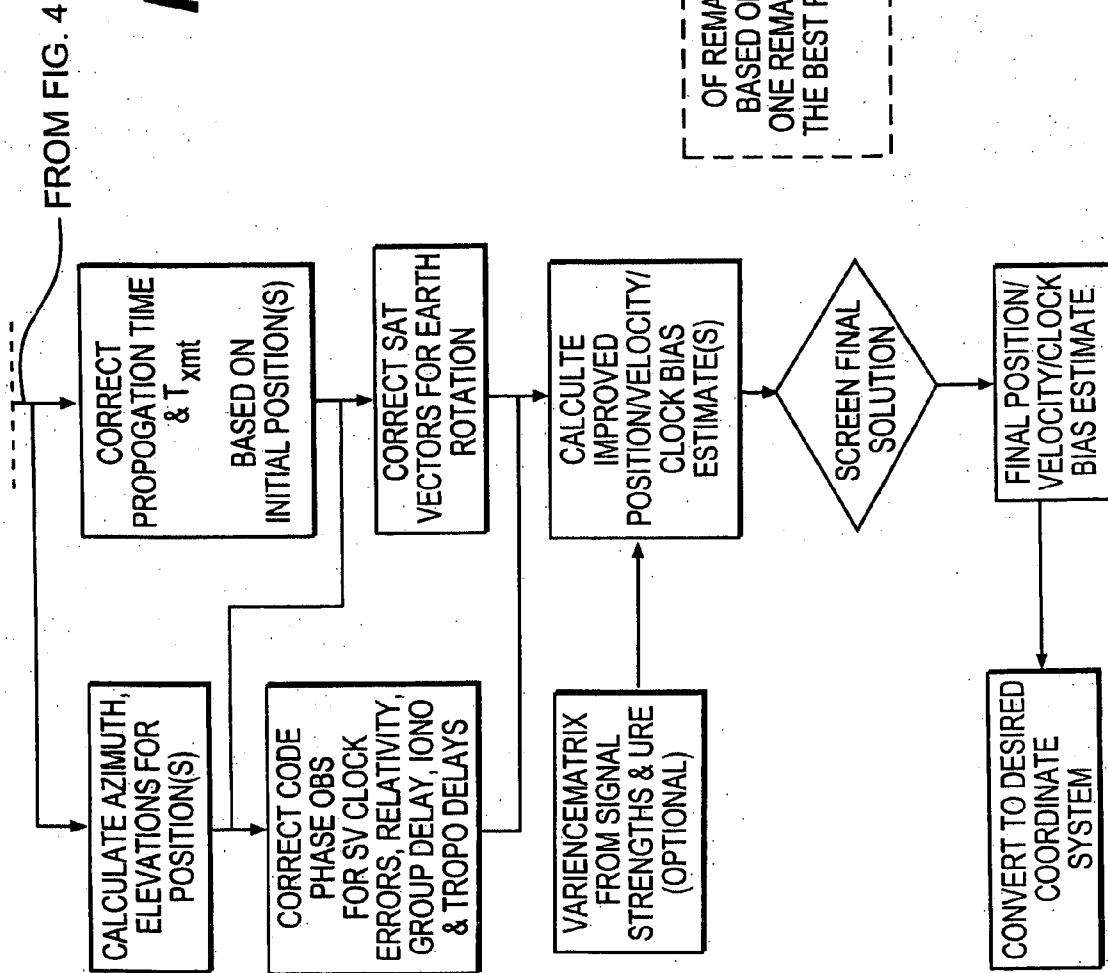

OF REMAINING CANDIDATE SOLUTIONS, RESCREEN BASED ON PROPERTIES ABOVE, AND IF MORE THAN ONE REMAINS, SELECT THE SOLUTION REPRESENTING THE BEST FIT OF OBSERVATION DATA USING THE FINAL SOLUTION RESIDUAL.

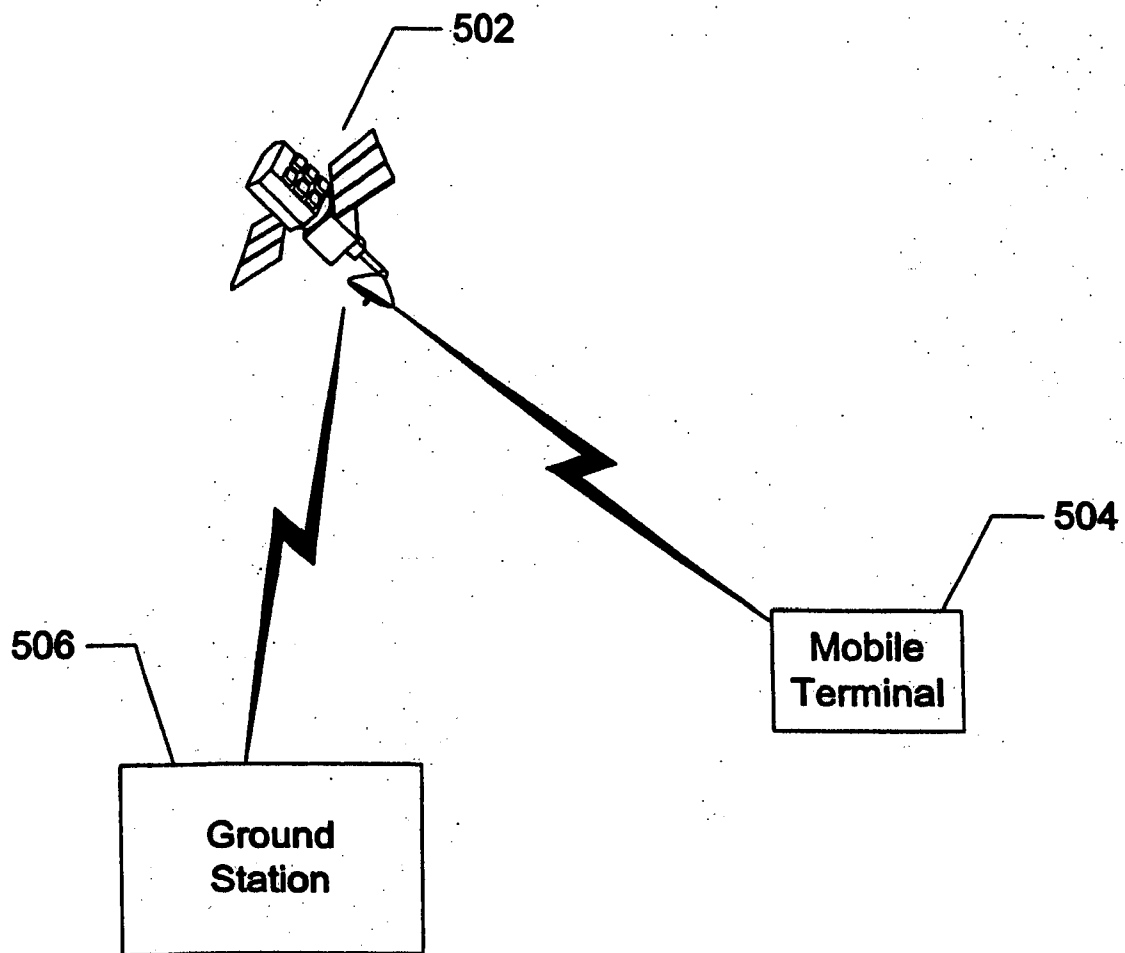

Figure 5

**SYSTEM AND METHOD FOR FAST ACQUISITION
REPORTING USING COMMUNICATION
SATELLITE RANGE MEASUREMENT**

[0001] This application is a continuation of U.S. non-provisional patent application Ser. No. 10/191,288, filed Jul. 10, 2002, which is a continuation of U.S. Pat. No. 6,480,788, which is a continuation-in-part of U.S. Pat. No. 6,243,648. This application also claims the benefit of priority to provisional application No. 60/243,430, filed Oct. 27, 2000, entitled "Fast Acquisition Position Reporting System Using Communication Satellite Range Measurement." The prior applications noted above are each incorporated herein by reference in its entirety.

BACKGROUND

[0002] 1. Field of the Invention

[0003] The present invention relates generally to methods and systems for tracking the location of devices near the surface of the Earth, and more particularly to a method and system for tracking a device near the surface of the Earth using a very fast acquisition portable transponder.

[0004] 2. Background of the Invention

[0005] Various techniques are available to determine the position of a device on the surface of the Earth. U.S. Pat. No. 3,063,048 discloses the use of the Doppler shift in a transmitted signal to determine the position of a device transmitting the signal. This patent teaches measuring when the Doppler shift frequency is changing at a maximum rate to determine the position of the object transmitting the signal undergoing the Doppler frequency shift. In this system, the satellite must continuously receive the signal being transmitted from the object to determine when the frequency is changing at its maximum to locate the object. As a result, the time to compute a position fix is unacceptably long for applications such as locating a satellite telephone.

[0006] The Global Positioning System (GPS) also provides geo-location capability. Moreover, it is desirable to know the position of a mobile terminal, such as a cellular telephone, and to have this position information at a central location (e.g., at a Service Operations Center or SOC).

[0007] One technique is to place a GPS receiver on the mobile terminal, calculate position in the GPS receiver, and transmit via satellite (or other communications system) the position fix to a central location. This method suffers from the Time-To-First-Fix (TTFF) limit inherent in GPS receivers upon waking up from a cold start. From the cold start state, a GPS receiver must download the GPS satellite almanac, ephemeris, and clock correction information. The TTFF limit effectively eliminates using a GPS receiver in situations where a long TTFF is unacceptable. For example, in wireless or cellular telephone telephony applications, it would not be acceptable to require the user to wait for the mobile terminal (i.e., the wireless or cellular telephone) to download GPS data prior to making a telephone call.

[0008] The present invention is therefore directed to the problem of developing a system and method for calculating the position of a mobile terminal, which can be accomplished rapidly using a minimal amount of power and equipment.

SUMMARY OF THE INVENTION

[0009] The present invention solves this problem by collecting observation data at the mobile terminal, forwarding the observation data to a central location, and performing the position calculations at the central location rather than at the individual mobile terminal. Thus, the mobile terminal of the present invention needs only to gather a few milliseconds of observation data, such as GPS code phase information, and then relays this observation data to a central station, via satellite or other relay means, for subsequent position calculation. In this manner, the present invention requires that the mobile unit be on only for very brief periods of time, so that a very fast (e.g. 1 second including data transmission time) position solution can be obtained. This would make practical, for example, the geolocation of a phone prior to a call being placed, which is particularly useful in satellite based phone services to control access and call routing decisions. The fast solution and minimal battery drain make practical the employment of a geolocating system in situations that may not otherwise economically justify such use.

[0010] According to one aspect of the present invention, a system for determining the location of an object located on or near the surface includes a communication satellite, a satellite gateway or earth station, a mobile terminal, and a service operations center. In this system, the communications satellite broadcasts an interrogation signal, to which the mobile terminal responds. The mobile terminal is disposed on the object, and includes a receiver, a transmitter and a processor. The receiver receives the interrogation signal from the communications satellite, and is capable of receiving signals being broadcast from GPS satellites. The processor measures at least one characteristic in each of the signals being broadcast from the GPS satellites upon receipt of the interrogation signal from the communications satellite. The mobile terminal transmits a reply signal at a predetermined time relative to receipt of the interrogation signal to the communications satellite. The reply signal includes the measured characteristic(s) in each of the signals being broadcast from the plurality of GPS satellites. The operations center receives the reply signal from the communications satellite, and calculates a position of the mobile terminal using time of arrival information and the measured characteristics returned by the mobile terminal.

[0011] In the above system, the measured characteristic(s) can include, for example, code phase information, carrier phase information, Doppler-shift information, or bit phase information. Code phase measurements alone are insufficient to unambiguously identify the position of the mobile terminal. The service operations center requires additional information to constrain the position solution. One means for constraining the position solution is to determine the range from the terminal to the communications satellite.

[0012] For this reason, in the first aspect of the present invention, the service operations center includes a processor that calculates a range between the communications satellite and the mobile terminal. In this calculation, the processor uses a time the reply signal arrived at the satellite gateway and a time difference between the broadcast of the interrogation signal to the mobile terminal and its receipt at the satellite gateway. To do so, the processor accounts for known delays in the signal path between the communications satellite and the mobile terminal and the point at which

the time-of-arrival information is measured at the satellite gateway. The processor also calculates an intersection curve between a sphere, whose radius is the range previously determined, and a model of the surface of the Earth. Furthermore, the processor determines several initial points on the intersection curve, one of which points must lie within a known convergence zone around the terminal. Next, the processor calculates candidate position solutions for each initial point, and then screens the candidate solutions using predetermined criteria and discards any candidates not satisfying the screening. Finally, if more than one candidate solution remains, the processor selects the solution representing a best fit of all the observation data.

[0013] In the above system, the predetermined criteria may include one or more selected of the following: a solution range to the communications satellite, solution residuals, a solution altitude, a solution clock bias, and a solution proximity to a beam boundary.

[0014] Not all types of communications systems provide the ability to measure propagation delay from a known site such as the satellite. A second preferred embodiment of the present invention solves the problem existing in the art by sending additional signal-related information as data to the SOC along with the code phase measurements. In the second preferred embodiment of the present invention, the additional signal-related information is a signal characteristic such as observed carrier frequency or observed Doppler shift of the carrier frequency. In addition to the measurement of the signal characteristic, in the preferred embodiment of the present invention, the time that the signal characteristic is measured is sent to the SOC. Alternatively, the time that the signal characteristic is measured is estimated from the time the message containing the observed data is received by the SOC. The code phase measurements are obtained at the GPS receiver, for example, in a cellular telephone. These measurements are sent to the SOC. In addition, the carrier frequency of the GPS signal sent by each of the GPS satellites is measured and sent to the SOC. The set of carrier frequency measurements form a set of observed carrier frequencies.

[0015] Using the carrier frequencies and a general region containing the location of the receiver candidate locations are determined. The candidate locations are determined by searching in the general region for points in the general region that are consistent with the observed carrier frequencies. From this set of candidate locations, the position of the mobile terminal is determined using the code phase measurements. The position is that candidate location that minimizes a set of residuals calculated using the code phase measurements. It can be seen that the second preferred embodiment of the present invention does not require a satellite (other than the GPS satellites) for operation.

[0016] Thus, one object of the present invention is to determine a location of a mobile terminal using a SOC.

[0017] Another object of the present invention is to reduce the power requirements of a mobile terminal in order to determine its position.

[0018] Another object of the present invention is to reduce the time required for a mobile terminal to be powered on so that its position can be determined.

[0019] Another object of the present invention is to increase the speed of acquisition of information required to determine the position of a mobile terminal.

[0020] Another object of the present invention is to perform calculations required to determine the position of a mobile terminal on a device other than the mobile terminal.

[0021] Another object of the present invention is to provide a location of a mobile terminal using a SOC without having control of the communication channel over which measurement data is sent from the mobile terminal to the SOC.

[0022] Another object of the present invention is to provide a location of a mobile terminal using a SOC with little or no change to the communication channel over which measurement data is sent from the mobile terminal to the SOC.

[0023] Another object of the present invention is to provide location of a mobile terminal by performing position calculations in a SOC and not in the mobile terminal.

[0024] Another object of the present invention is to provide a ground-based (i.e., terrestrial) technique for determining position of a mobile terminal using GPS satellite measurements.

[0025] These and other objects of the present invention are described in greater detail in the detailed description of the invention, the appended drawings and the attached claims.

BRIEF DESCRIPTION OF THE DRAWINGS

[0026] FIG. 1 depicts a block diagram of an exemplary embodiment of a system according to the present invention.

[0027] FIG. 2 depicts a diagram of an exemplary embodiment of the method according to the present invention.

[0028] FIGS. 3(a) and 3(b) depicts a geographical representation of the method of FIG. 2 used to locate a terminal unit according to the present invention.

[0029] FIG. 4 depicts the various parameters returned to the Service Operations Center and used in calculating the position solution, and a flow chart of the calculations performed by the processor in the SOC.

[0030] FIG. 5 is a schematic illustration of an exemplary embodiment of a system according to a second embodiment of the present invention.

DETAILED DESCRIPTION OF THE INVENTION

[0031] Referring to FIG. 1, an exemplary embodiment of a system [10] includes a Service Operations Center (SOC) [11], which is coupled to a Satellite Gateway (SG) [12], a communications satellite [13], satellites in the Global Positioning System (GPS) [14-17], a terminal unit [18], and a Reference Network (RN) [19]. The terminal unit [18] receives signals from multiple GPS satellites [14-17], and the communications satellite [13].

[0032] The terminal unit [18] receives a broadcast message on its forward communications satellite link, which broadcast message contains timing and acquisition aiding information. Following receipt of the message, the terminal unit performs its observation data collection function, and

then transmits back to the SOC the observation data, along with any necessary system and/or status information, at a fixed delay from the received broadcast information. All processing of the observation data is done at the SOC [11]. The terminal unit [18] merely takes measurements and returns the observations as part of the broadcast/response cycle.

Service Operations Center

[0033] The SOC [11] controls the operation of the system [10] of the present invention. The SOC [11] broadcasts a signal on the forward link which contains timing and acquisition aiding information that can be received and used by the mobile terminals to synchronize time and to rapidly acquire their intended GPS signals, from which they take their observation data set. The forward broadcast can also contain command and control protocols for individual and/or groups of terminals.

[0034] The return signal from the terminal [18] includes the observation data along with any system, status or protocol information necessary to operate the system.

[0035] The return signal is synchronized to the forward signal by a specific and known delay, which allows the Satellite Gateway [12] to take an additional measurement of the round-trip signal propagation time and absolute Time-of-Arrival (TOA).

[0036] This calculated propagation time is used along with certain observation data to determine position. The SOC also collects, on a continuous basis, all ancillary information necessary to the position calculations from a Reference Network [19] and other sources. As an example, this information includes:

- [0037] 1. GPS broadcast ephemerides and clock correction coefficients for all satellites in view over the region of interest;
- [0038] 2. Current GPS Almanac;
- [0039] 3. Current ionospheric and tropospheric parameters;
- [0040] 4. Current Status messages and advisories;
- [0041] 5. Current communications satellite state vector and operational status; and
- [0042] 6. Differential correction data (if used).

Satellite Gateway

[0043] The Satellite Gateway [12] consists of satellite communications modems (channel units) and associated control and management equipment and software. The gateway maintains an accurate time and frequency reference for control of the forward link broadcast, and for propagation time measurements. The terminal needs only to accurately respond relative to the forward signal and therefore can use a much less accurate, and low power, internal reference. The satellite gateway [12] is a traditional satellite communications facility. Therefore it also includes antenna, transmitter, amplifier, up/down conversion, and other standard satellite communications equipment and software that is not shown, but is known to those of skill in this art.

Communications Satellite

[0044] The communications satellite can be any (LEO, MEO, GEO) satellite capable of transponding the forward and return signals to/from the terminal and satellite gateway. It could also be a balloon, airplane, remotely piloted vehicle or other aircraft operating within the atmosphere (Non-Bent pipe satellites can also be used if all delays in the transmission path are known and removed). The Satellite (or aircraft) position and velocity information, as well as transponder group delay and other operational parameters must be known. Examples of suitable communications satellites include:

- [0045] 1. Orbcomm
- [0046] 2. Globalstar
- [0047] 3. ICO
- [0048] 4. AceS
- [0049] 5. Hughes MSAT
- [0050] 6. Thuraya
- [0051] 7. Iridium

[0052] Other communications satellites are possible for use in the present invention, which satellites are known to those of skill in the art.

Terminal Unit

[0053] The present invention only requires that the mobile terminal [18] receive a signal, make observations (measuring certain aspects of the GPS signals), and return another signal, which includes the observation data, and can be accomplished over a very short interval. There are various types of observation data that can be relayed to the central site to enable the central site to determine the position of the mobile terminal.

[0054] One possibility is to collect code phase and/or carrier phase information inherent in the GPS signal. This enables the mobile unit to remain on for a very short time, thereby helping to minimize the Time-To-First-Fix. Other signal characteristics that can be measured by the terminal are Doppler-shift information, or bit phase information. Another possibility is to digitize a brief interval of the received GPS signal and transmit the digital data to the central site. The central site can then reconstruct the received signal, and determine the position based on certain characteristics in the received signal, such as Doppler shift, code phase of arrival of the received signal, bit phase information, etc.

Exemplary Embodiment of a Method of the Present Invention

[0055] The following provides an exemplary embodiment of the present invention, in which Code Phase of Arrival (COA) information is used to determine the position of the mobile terminal. Other measurements are also possible, as stated above.

[0056] Referring to FIG. 2, at time to, a Satellite Gateway (SG) [12] transmits a forward signal, with a marker event, through a communications satellite [13] to a region of the

Earth bounded by the satellite beam pattern as in FIG. 3. An example of a marker event is a synchronization data pattern in the packet preamble.

[0057] Depending on the communications satellite employed, multiple regions may be covered by different beams. Consequently, signals may be transmitted to these regions either in sequence or simultaneously.

[0058] The satellite [13] receives the signal at time t_1 , and retransmits the signal back to earth at time t_2 . Subsequently, at time t_3 the mobile terminal [18] receives the signal with the marker event.

[0059] When the mobile terminal [18] needs to report its position, it searches for the SG signal in the satellite down-link. This signal contains information to aid acquisition (e.g., a prioritized list of GPS satellite vehicles in view over the coverage region, Doppler offset information, timing reference, etc.). Satellite vehicles in the list are prioritized to allow the mobile terminal [18] to search for and select those satellites that provide a favorable observation set of GPS satellites (i.e., to minimize dilution of precision, exclude degraded or non-operational satellites, etc.). The SG [12] also synchronizes the outbound transmission relative to a GPS timing reference.

[0060] Using the acquisition information recovered from the forward message, the mobile terminal [18] receives a multitude of GPS signals starting at time t_{obs} , which is a fixed and known time interval from t_3 . The operation of the receiver is synchronized with the signal received from the SG [12]. In turn, the signal received from the SG [12] is synchronized to GPS time (such as the X1 epoch). Consequently, the receiver clock offset associated with the GPS spreading codes used to recover the signals can be estimated back at the ground station with reasonable (less than +/-0.5 milliseconds) accuracy.

[0061] The terminal [18] measures the Code Phase of Arrival (COA) of each of the GPS signals at t_{obs} . The terminal [18] then relays this measurement to the SG [12] by transmitting a return signal back through the communications satellite at time t_4 , which also has a fixed and known relationship to the inbound timing reference t_3 .

[0062] The communications satellite [13] receives the return signal from the mobile 2 terminal at time t_5 and retransmits the same signal back to the SG [12] (or another ground station) at time t_6 .

[0063] The return signal is received by the SG at time t_7 and compared to the forward link timing reference and a round-trip propagation time measurement is taken. Absolute Time of Arrival (TOA) measurements are also taken. The SG [12] recovers the contents of the return transmission and forwards the 30 data along with its propagation time and TOA measurements to the SOC [11].

Exemplary Embodiment of Position Determination Calculations Performed at Service Operations Center

[0064] The SOC [11] calculates the magnitude of the range vector between the communications satellite [13] and the terminal [18] by removing all known delays from the propagation time measurement. This is accomplished using the communications satellite position, velocity and transponder group delay information, the Satellite Gateway antenna position, known signal delays in the ground cable/equipment path, and if desired, any atmospheric or other transmission path delays that can be modeled. These delays and the relationships between the times are depicted in FIG. 2. This range calculation is fairly standard and common practice in the satellite communications field, and would be known to those of skill in the art.

[0065] After the range between the communications satellite [13] and the terminal [18] is determined, the SOC [11] determines an arc of possible locations. This is determined by computing an intersection curve 31 (see FIG. 3) of a sphere, centered at the communications satellite having a radius given by the calculated range from the satellite [13] to the terminal [18], with a model of the surface of the Earth.

[0066] The Earth can be modeled as a mathematical approximation, such as an ellipsoid, or a geoid model, or with Terrain Elevation Data. The following is one possible example of these calculations using an ellipsoid model:

[0067] The Earth can be modeled as an ellipsoid of revolution. The ellipsoid parameters depend on choice of reference frame (e.g., WGS-84). This surface can be expressed:

$$\frac{x^2}{a^2} + \frac{y^2}{a^2} + \frac{z^2}{b^2} = 1$$

[0068] Where a and b are constants representing axes of the chosen ellipsoid.

[0069] One possible parameterization of the ellipsoid surface could be:

[0070] $x=a \sin(\phi)\cos(\lambda)$

[0071] $y=a \sin(\phi)\sin(\lambda)$

[0072] $z=b \cos(\phi)$

[0073] $\phi=0$ to π with 0 being the positive z-axis. And $\lambda=0$ to 2π with 0 being the positive x-axis.

[0074] The equation of a sphere at point (X_s, Y_s, Z_s) with radius ρ (slant range):

$$(X-X_s)^2+(Y-Y_s)^2+(Z-Z_s)^2=\rho^2$$

[0075] Substituting the Ellipsoid equation into the Sphere equation and simplifying gives:

$$\frac{(a \sin(\phi)\cos(\lambda)-X_s)^2+(a \sin(\phi)\sin(\lambda)-Y_s)^2+(b \cos(\phi)-Z_s)^2}{\rho^2} = 1$$

$$\frac{(b^2-a^2)\cos(\phi)^2-2a \sin(\phi)\cos(\lambda)X_s-2a \sin(\phi)\sin(\lambda)Y_s-2b \cos(\phi)Z_s}{\rho^2-a^2-r^2} = \rho^2$$

[0076] Organizing the coefficients to allow a ‘choose Phi - - - solve Lambda’ Scenario:

$$A=-2a \sin(\phi)X_s$$

$$B=-2a \sin(\phi)Y_s$$

$$C=(b^2-a^2)\cos(\phi)^2-2b \cos(\phi)Z_s+r^2+a^2-\rho^2$$

$$A \cos(\lambda)+B \sin(\lambda)+C=0$$

[0077] Choosing Phi over the range of interest, calculating coefficients, and solving for Lambda gives:

$$\lambda = 2 \tan^{-1} \left[\frac{(B \pm \sqrt{B^2 + A^2 - C^2})}{(A - C)} \right]$$

[0078] The spacing of points on the parameterized intersection curve depends on spacing of chosen points ϕ and the earth model chosen and is depicted in FIG. 3(b). The choice of parameterization method need only guarantee that at least one of the initial points will fall within the convergence zone around the true solution. As used herein, convergence zone refers to the area around the location of the mobile terminal in which a point must lie to guarantee that the position calculation will converge to that location. The size of the convergence zone will vary depending on number, quality and type of observation data used, but as an example, the convergence zone for the code phase observations is approximately a radius of 75-80 Km (See FIG. 3(b)).

[0079] One could also use a Geoid model or digital terrain information to construct a similar arc of points by keeping only those points with a range to the communication satellite that is within a certain tolerance.

[0080] Points could be sub-sampled or interpolated as desired due to the fact that these only represent a first approximation as input to the least squares algorithm. It is only required that at least one point on the arc lay within the guaranteed convergence zone around the true solution.

[0081] Only that portion of the arc within the region of the Earth bounded by the satellite beam pattern is retained by the SOC. Refer to FIG. 3(a), which depicts the bounding of the arc (or parameterized intersection curve) by the beam pattern.

[0082] The SOC next determines the time that the mobile terminal collected the GPS signal (t_{obs}). The collection time is determined from the range between the satellite and the terminal and SG. The known delays in the transmission paths (i.e., transponder group delay, atmosphere, etc.), the terminal collection method (i.e., fixed delay from t_3 and integration period), and the absolute TOA measurement.

[0083] The SOC then employs a satellite orbit model to estimate the positions of the GPS satellites at their time of transmission (t_{xmt}). GPS t_{xmt} is calculated from t_{obs} less the GPS signal transit time (user must also correct for earth rotation during signal transit time if working in Earth fixed coordinates).

[0084] Using each point on the arc as an initial guess, an iterative least squares technique fits the observation data to the predicted data and minimizes residual error. One example of these calculations follows:

[0085] Create system of linearized normal equations for least squares solution.

$$-\frac{X^k - X^0}{(P_i^k)^0} x_i - \frac{Y^k - Y^0}{(P_i^k)^0} y_i - \frac{Z^k - Z^0}{(P_i^k)^0} z_i + c\Delta t_i = (P_i^k)_{obs} - (P_i^k) - \epsilon_i^k$$

$$(P_i^k)_{obs} - (P_i^k)^0 - b_i$$

$$A\hat{x} = b - \epsilon$$

[0086] We assume the code observation P_{obs} is corrected for the clock offset of the satellite according to the broadcast ephemerides (and atmospheric delays if desired). The preliminary value P_0 is calculated from the initial coordinates of the satellite and from the arc of points generated previously. First guess at receiver clock offset can be estimated from broadcast signal timing and slant range to the terminal. Alternately, an additional observation may be taken to guarantee a unique solution if receiver clock offset cannot be estimated to within 0.5 msec.

$$\begin{bmatrix} \frac{X^1 - X_i}{\rho_i^1} & \frac{Y^1 - Y_i}{\rho_i^1} & \frac{Z^1 - Z_i}{\rho_i^1} & 1 \\ \frac{X^2 - X_i}{\rho_i^2} & \frac{Y^2 - Y_i}{\rho_i^2} & \frac{Z^2 - Z_i}{\rho_i^2} & 1 \\ \vdots & \vdots & \vdots & \vdots \\ \frac{X^m - X_i}{\rho_i^m} & \frac{Y^m - Y_i}{\rho_i^m} & \frac{Z^m - Z_i}{\rho_i^m} & 1 \end{bmatrix} \begin{bmatrix} x_i \\ y_i \\ z_i \\ c\Delta t_i \end{bmatrix} = b - \epsilon$$

$$\begin{bmatrix} x_i \\ y_i \\ z_i \\ c\Delta t_i \end{bmatrix} = (A^T C A)^{-1} A^T C b$$

$$\hat{r} = b - A\hat{x}$$

[0087] The right side of the normal equations b represents the difference between the expected and observed code phase (modulo 1 msec) and is ambiguous. The receiver clock offset is also treated as a modulo 1 msec value. The integer ambiguity is assumed by the choice of preliminary coordinates. Matrix b is kept in the +/-0.5 msec range as a difference between two modulo 1 msec values. This forces convergence to a solution within ~150 Km from the preliminary coordinates. Matrix C is the weight matrix (inverted covariance matrix) derived from signal strengths and/or GPS satellite URE (User Range Error) values and is used in a weighted least squares solution, or set to the identity matrix for a non-weighted solution. Matrix r is the residuals matrix and can be weighted and/or summed, or analyzed as a covariance matrix with minor manipulation.

[0088] After convergence, this estimated position solution is then screened against the measured range to the communications satellite (with known tolerance), satellite beam boundaries, an acceptable altitude range (with respect to the ellipsoid, geoid or elevation model used), an acceptable receiver clock offset range, and a maximum residual threshold. Those position estimates not meeting these criteria are discarded. An example for each method follows:

[0089] Range: The initial estimate(s) lie on an arc of constant range from the communication satellite. If the candidate solution lies outside the known tolerance of this range estimate then it is discarded.

[0090] Altitude: The initial estimate(s) lie on the chosen earth model surface. If the candidate solution lies above/below the maximum/minimum height possible relative to this earth model then it is discarded.

[0091] Beam: The initial estimate(s) lie within the beam coverage footprint. If the candidate solution lies outside the beam boundary it is discarded.

[0092] Clock Bias Tolerance: The calculated receiver clock bias must fall in the range of the estimated clock bias

(with known tolerance) from the propagation time measurement. If the candidate solution falls outside this range it is discarded. Therefore, as the accuracy on the propagation time measurement increases, this becomes a more valuable discriminator.

[0093] Residuals: It has been observed that the residuals (goodness of fit) for the converged solutions (for an over-determined problem) are smallest for the true position estimate. The residuals provide an effective discriminator between ambiguous position solutions when the above least squares method is used. Therefore, an empirically determined or calculated threshold can be used (alone or in conjunction with the other screening criteria) to screen false candidates.

[0094] Doppler: The observed Doppler can be compared with the expected Doppler at each of the candidate points. Candidate points falling outside a pre-determined screening criterion are discarded. One such criterion is the sum-of-the-square-of-the-differences criterion. At each candidate point, the sum of the squares of the differences of the measured and calculated Doppler is determined. This calculation is compared against a pre-determined threshold. Those candidate points for which the calculation exceeds the threshold are discarded.

[0095] The remaining position estimate(s) can then be improved by using Atmospheric (Ionospheric and/or tropospheric) corrections to the code phase observations to further improve the position accuracy of this process (if desired), and then subjected to a final screening and residual comparison, (e.g., minimum RMS) and the best point selected. Other screening criteria could be employed based on geospatial data sets, or application specific criteria (e.g., must be over land, or near a rail line, etc.).

[0096] It should be noted that if the area of interest is small enough (i.e., within the 20 guaranteed convergence zone), such as a very narrow satellite beam, an area or city covered by an aircraft platform, or a cellular tower coverage zone, then the additional range measurement and the screening process are unnecessary, and a unique solution will result from an initial estimate at the center of the area of interest.

[0097] Well known differential correction (DGPS) techniques can be applied to the final correct position to further increase its accuracy since all the same error sources in a standard GPS solution apply here as well.

[0098] FIG. 4 depicts the above calculations performed by a processor in the SOC [11] in flow chart form, which is suitable for implementing in software for execution on a general purpose computer. Upon receipt of the information packet at the SOC [11] containing the observation data from the terminal [18] and the measurement and ancillary data from the SG [12], the SOC processor obtains the latest state vector for the communication satellite [13], and the ephemeris, clock and atmospheric data for the GPS satellites [14-17].

[0099] The SOC [11] then performs a series of calculations as shown in the flow diagram resulting in several candidate position solutions. The candidate solutions are then screened per the criteria described previously, and another iteration is performed which can include the atmospheric correction data. If there is more than one remaining

solution then a final screen and selection takes place. The final position obtained can then be converted to the desired coordinate system.

[0100] In a second preferred embodiment, the present invention uses timing correction information generated by communication satellite systems to synchronize data transmission from multiple mobile terminal to avoid overlapping data transmissions. For example, systems using TDMA protocols, such as GSM systems generate timing correction information that is used to adjust data transmission timing of a plurality of mobile terminals to avoid data from one mobile terminal overlapping a time slot assigned for data from another mobile terminal. TDMA systems have signal structures containing a plurality of time slots. Each of the time slots is assigned to a particular mobile terminal or is used for some other purpose. One problem with such systems is that due to different propagation delays between various mobile terminals and the communication satellite, a data packet sent from one mobile terminal can overlap with the time slot assigned to another mobile terminal. To avoid this data packet overlap, TDMA systems provide synchronization information to each of the mobile terminals to avoid data packet overlap.

[0101] FIG. 5 illustrates a communication system according to a second embodiment of the present invention. A communication satellite 502 transmits a forward control packet to a mobile terminal 504. Typically, the forward control packet includes information regarding the time slot in which the mobile terminal can send an access request to communication satellite 502. Mobile terminal 504 receives the forward control packet and synchronizes to it. At the appropriate time, mobile terminal 504 transmits an access request to communication satellite 502. Communication satellite 502 receives the access request and measures the timing of the received access request with respect to the forward control packet's timing. The measured timing is compared to an internal reference. Based on this comparison, timing correction information is generated. The timing correction information is used to adjust data transmission timing of mobile terminal 504 so that data packets it sends are received by communication satellite 502 properly aligned in the appropriate time slot of the reverse channel. Communication satellite 502 transmits a response message to mobile terminal 504 containing the timing correction information. Mobile terminal 504 receives the response containing the timing correction information. Using the timing correction information, mobile terminal adjusts its transmitter timing. This adjustment is to advance, delay or maintain the transmitter's timing. Mobile terminal 504 then sends the GPS code phase data and the timing correction information to communication satellite 502 to be sent to a ground station 506. Ground station 506 receives the GPS code phase information and the timing correction information. Ground station 506 then relays this information to a service operation center (described above), where it is used to determine position of the mobile terminal. Alternately, ground station 506 can initiate the transmission of the forward control packet, receive the access request, compare it to an internal reference and determine the timing correction information.

[0102] The timing correction information is a measure of the propagation delay from the mobile terminal to the communication satellite. A range arc (described above) is determined using the propagation delay. The range arc has

communication satellite **502** at its origin. Determination of the range arc using the propagation delay between mobile terminal **504** and communication satellite **502** is well known to those skilled in the art. This range arc is used to determine position as described above. Consequently, the range arc determined from the propagation delay corresponding to the timing correction information determined as part of the communication satellite's protocol is used as an input to the range ambiguity resolution technique described above.

[0103] Mobile terminal **504** can alternatively be programmed to send the timing correction information along with GPS code phase measurements to the SOC. The SOC uses this information to determine the mobile terminal's position. Modifying mobile terminal **504** to send this data to the SOC eliminates the need to modify or augment existing ground station equipment to provide these timing measurements directly to the service operations center.

[0104] The foregoing disclosure of embodiments of the present invention has been presented for purposes of illustration and description. It is not intended to be exhaustive or to limit the invention to the precise forms disclosed. Many variations and modifications of the embodiments described herein will be obvious to one of ordinary skill in the art in light of the above disclosure. The scope of the invention is to be defined only by the claims appended hereto, and by their equivalents.

What is claimed is:

1. A method for determining a location of a remote terminal, comprising:

receiving a communication from a remote terminal via a communications satellite, said communication in response to an interrogation signal and including a measured characteristic of a plurality of signals broadcast by a respective plurality of GPS satellites;

determining a range measurement between the communications satellite and the remote terminal using said received communication;

determining an arc of possible locations of the remote terminal using said determined range measurement; and

identifying a final location of the remote terminal using said measured characteristics of said plurality of signal broadcast by said respective plurality of GPS satellites.

2. The method of claim 1, wherein said range measurement determination is based on a removal of known delays from a propagation time measurement.

3. The method of claim 1, wherein said determination of said arc of possible locations is based on a model of the surface of the Earth.

4. The method of claim 1, wherein said measured characteristic is a code phase of arrival measurement.

5. A method in a remote terminal that enables position determination, comprising:

receiving an interrogation signal from a communications satellite;

measuring in response to said interrogation signal at least one characteristic of a plurality of signals broadcast by a respective plurality of GPS satellites;

transmitting a response to a centralized location via said communications satellite, said response including said measured characteristic of said plurality of signals broadcast by said respective plurality of GPS satellites, wherein said measured characteristic is used by said centralized location to identify a final location of the remote terminal from an arc of possible locations defined by a range measurement between the communications satellite and the remote terminal.

6. The method of claim 5, wherein said range measurement is determined by removing known delays from a propagation time measurement between said centralized location and the remote terminal.

7. The method of claim 5, wherein said measured characteristic is a code phase of arrival measurement.

8. A computer-readable medium that stores a program for controlling a computer device to perform a method for determining a location of a remote terminal, the method comprising:

receiving a communication from a remote terminal via a communications satellite, said communication in response to an interrogation signal and including a measured characteristic of a plurality of signals broadcast by a respective plurality of GPS satellites;

determining a range measurement between the communications satellite and the remote terminal using said received communication;

determining an arc of possible locations of the remote terminal using said determined range measurement; and

identifying a final location of the remote terminal using said measured characteristics of said plurality of signal broadcast by said respective plurality of GPS satellites.

* * * * *