

No. 753,452.

PATENTED MAR. 1, 1904.

W. A. VAN BRUNT.
PRESSURE REGULATING MECHANISM FOR DRILLS.
APPLICATION FILED JAN. 14, 1904.

NO MODEL.

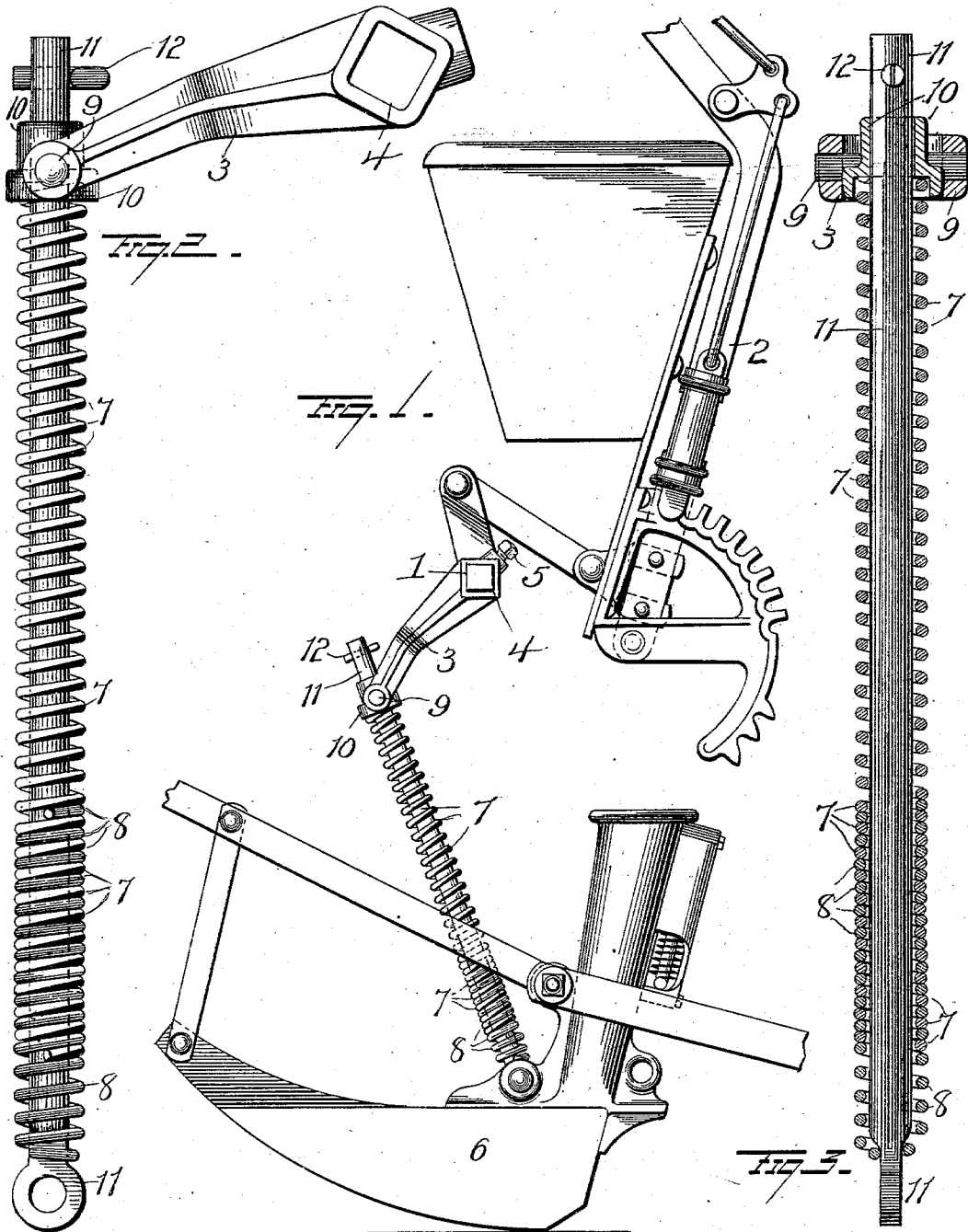

WITNESSES
E. Nottingham
G. F. Downing

INVENTOR
W. A. Van Brunt
By *H. A. Seymour*
Attorney

UNITED STATES PATENT OFFICE.

WILLARD A. VAN BRUNT, OF HORICAN, WISCONSIN.

PRESSURE-REGULATING MECHANISM FOR DRILLS.

SPECIFICATION forming part of Letters Patent No. 753,452, dated March 1, 1904.

Application filed January 14, 1904. Serial No. 189,039. (No model.)

To all whom it may concern:

Be it known that I, WILLARD A. VAN BRUNT, a resident of Horican, in the county of Dodge and State of Wisconsin, have invented certain new and useful Improvements in Pressure-Regulating Mechanism for Drills; and I do hereby declare the following to be a full, clear, and exact description of the invention, such as will enable others skilled in the art to which it appertains to make and use the same.

My invention relates to an improved pressure-regulating mechanism for drills, and more particularly to improved spring-tension adjusting means, the object of the invention being to provide improvements of this character which will be extremely simple in construction, easy to operate, cheap to manufacture, and strong and durable in use.

With this object in view the invention consists in certain novel features of construction and combinations and arrangements of parts, as will be more fully hereinafter described, and pointed out in the claims.

In the accompanying drawings, Figure 1 is a view in side elevation, illustrating my improvements on a drill. Fig. 2 is an enlarged view of the pressure-regulating springs, and Fig. 3 is a view in vertical section of Fig. 2.

1 represents an angular shaft turned by a hand-lever 2 and provided at intervals with crank-arms 3, having angular collars 4 to receive the shaft and secured against lateral displacement by set-screws 5. These arms are adapted to raise and lower rods 11 and hoes 6, with which said rods are connected, and on said rods my improved pressure-regulating springs 7 and 8 are located, as will now be described in detail, the below description of one mechanism applying alike to all of the series.

The arms 3 are bifurcated or forked at their outer ends and made with alined openings to receive trunnions 9 on opposite sides of a ring 10, located on rod 11 and whose upward movement on said rod is limited by a cotter-pin 12, located in an opening in rod 11 above the ring. The lower end of rod 11 is flattened and forms an enlarged perforated head to receive a bolt or pin to secure it to the hoe.

On rod 11 two coiled springs 7 and 8, above referred to, are located, spring 7 bearing in

the recessed lower face of ring 10 and the other spring, 8, mounted on the lower portion of the rod and bent against the flattened end thereof to prevent its turning on the rod, the meeting ends of said springs intercoiled, so that by turning spring 7 in one direction the springs will further intercoil to shorten them and decrease the spring tension, while if turned in the reverse direction will uncoil and lengthen the double spring, giving a correspondingly-increased tension.

If desired, upper spring 7 might be held stationary and lower spring 8 turned to increase or decrease the spring tension.

Slight changes might be made in the general form and arrangement of the parts described without departing from my invention, and hence I do not restrict myself to the precise details set forth, but consider myself at liberty to make such slight changes and alterations as fairly fall within the spirit and scope of my invention.

Having fully described my invention, what I claim as new, and desire to secure by Letters Patent, is—

1. A pressure-regulating mechanism, comprising two coiled springs intercoiled one within the other, and one held against rotation to permit the other when turned to lengthen or shorten said double spring.

2. A pressure-regulating mechanism for drills, comprising a lifting-rod, a hoe connected to the lower end of said rod, a lifting-arm connected with the upper end of said rod, two coiled springs on said rod intercoiled at their meeting ends, one spring held against turning and the other free to turn.

3. A pressure-regulating mechanism for drills, comprising a lifting-rod, a hoe connected to the lower end of said rod, a lifting-arm, a ring on said rod and pivotally connected with said arm, a pin passed through the rod limiting the upward movement of the ring, two coiled springs on said rod, one bearing against the ring and the other against the lower end of the rod, and intercoiled at their meeting ends, one spring held against turning and the other free to turn.

4. A pressure-regulating mechanism for drills, comprising a lifting-rod connecting a

lifting-arm with a hoe, coiled springs on said rod intercoiled at their meeting ends and exerting downward pressure on the hoe and adapted when one is turned and the other held, 5 to lengthen or shorten said double spring, substantially as and for the purpose set forth.

5. A pressure-regulating device, comprising a rod, a coiled spring thereon, means for limiting the movement of said spring in one 10 direction, and a device on the rod, movable, when the spring or rod are turned, farther into or out of, the convolutions of said spring to regulate the tension thereof.

6. A pressure-regulating device, comprising a rod, a coiled spring thereon, means for limiting the movement of said spring in one 15 direction, and a device on the rod, movable, when the spring or rod is turned, farther into or out of the convolutions of said spring 20 to regulate the tension thereof by reason of

lengthening or shortening the spring between its points of contact.

7. A pressure-regulating device for drills, comprising a hoe, a lifting-rod connected therewith, a lifting-arm connected with said 25 rod at or near its upper end, a coiled spring loose on the rod and bearing at its upper end against the lifting-arm connection, and a device fixed to the rod and engaging the spring between its convolutions, so that when the 30 spring is turned, it will be screwed up or down on said device to lengthen or shorten the spring and adjust the tension thereof.

In testimony whereof I have signed this specification in the presence of two subscribing witnesses. 35

WILLARD A. VAN BRUNT.

Witnesses:

FRED. H. CLAUSEN,

A. W. WILCOX.