

Nov. 9, 1954

E. BOCCHINO

2,693,688

WRIST CIGARETTE LIGHTER

Filed Nov. 23, 1951

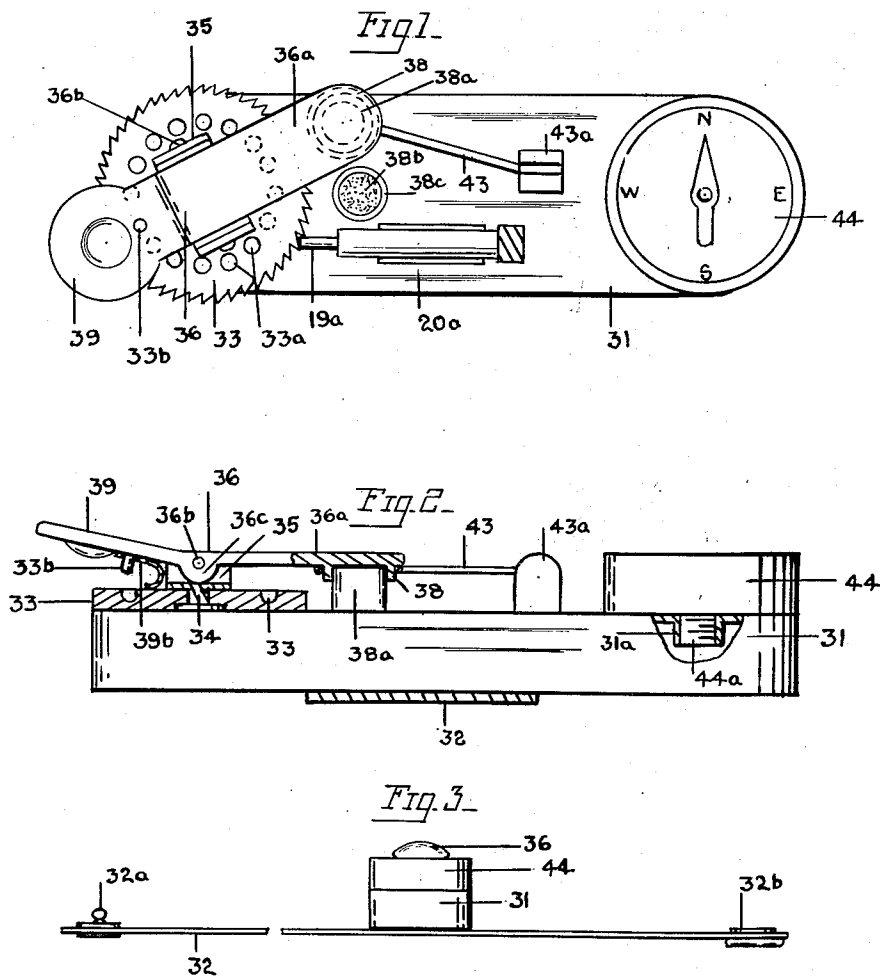

INVENTOR.

Ernest Bocchino

1

2,693,688

## WRIST CIGARETTE LIGHTER

Ernest Bocchino, Clifton, N. J.

Application November 23, 1951, Serial No. 257,810

2 Claims. (Cl. 67-4.1)

This invention relates to an improved cigarette lighter and one of its objects is to provide a lighter for cigarettes which can be worn by a wrist strap attached to the wrist of the user, and operated by a manual lever action close to the wrist, so that a shallow construction is provided, which will not project greatly beyond the wrist.

Another object of the invention is the provision of a lighter for cigarettes having a sparking wheel mounted in parallel relation to the top of the fuel container, and a rocking lever which can be depressed and swung when depressed to turn the sparking wheel against a spring pressed flint, so that a torch wick can be ignited by the sparks generated by the movement of the sparking wheel.

A further object of the invention is to provide the lever with a snuffer cap which is normally held in snuffing position over the upper end of the torch tube and wick, and which is raised when the lever is manually depressed and swung to actuate the sparking wheel.

With the above and other objects in view the invention comprises certain new and useful constructions, combinations and arrangements of parts, clearly described in the following specification and fully illustrated in the drawings, in which:

Fig. 1 is a top plan view of the improved cigarette lighter, showing the operating lever displaced from the torch tube and wick.

Fig. 2 is a vertical sectional view taken through the lever and the sparking wheel, partly broken away.

Fig. 3 is a view in elevation, looking from the rear end of the lighter, showing the lighter attached to a wrist strap.

Referring to the accompanying drawings, 31 designates a fuel tank or container, having a flat top on which is mounted the sparking flint 19a by means of its spring housing 20a. This spring housing 20a and the flint are shown in parallel relation to the sides of the container or fuel tank, and parallel to its flat top.

A circular sparking wheel 33 is mounted to turn on the pivot 34, which is attached to the top wall of the container or fuel tank 31, and on this pivot the U-shaped bracket 35 is also mounted to turn.

On this bracket 35 a lever 36 is pivotally mounted by means of its shaft 36b, which extends through the bracket and through the bearing ears 36c of the lever. The lever 36 is formed with a lever leg 36a, which is normally parallel to the top of the container 31, and is provided on its end with a snuffer cup 38, which snugly fits over the torch tube 38a, which projects vertically from the container 31, and is provided with an absorbent wick 38b which is exposed in the usual manner at its upper end.

The lever 36 is also provided with a short arm or leg 39, which projects upwardly and endwise from the bracket thereof, and is formed with a concave finger seat therein. This lever arm or leg is provided with a pin 33b, which is normally elevated above the upper side of the sparking wheel 33 by means of the U-shaped spring 39b, which is disposed under the lever arm and against the top of the fuel container 31. The sparking wheel is formed with a circular row pin sockets 33a, which are concentric to the ratchet teeth of the wheel, and are adapted to successively receive the pin 33b, which forms an element for coupling the lever 33 to the sparking wheel.

A wire spring 43 is connected to the outer end of the lever arm or leg 36a at one end and to a post 43a, which is mounted on the top wall of the container, at the other end. The tension of this spring normally holds the lever snuffing cup 38 over the torch tube and its wick. By man-

2

ually depressing the arm 39 the snuffing cup 38 will be raised above the torch tube, and at the same time the pin 36d of the lever arm 39 will be coupled to the sparking wheel, by entering one of the pin sockets 33a of this sparking wheel. By swinging the lever around while coupled to the sparking wheel, by the depressed pin 33d, the ratchet teeth of the sparking wheel will be moved against the exposed outer end of the sparking flint 19a, and sparks will be generated and projected in the path of the torch tube and its wick, and the fuel vapor of this tube and its exposed wick will be ignited and flaming of the gaseous fuel supplied to the container will start.

When the lever is released it will swing back to its initial position, snuffing the flame, and disconnecting the pin 36d from the sparking wheel, without turning this sparking wheel.

The improved cigarette lighter is attached to a wrist strap 32, suitably attached to the bottom wall of the container, and one end of this strap is provided with a male button snap element 32a and the other end is provided with a female button snap element 32b, or may be provided with any other coupling means. By connecting the ends of the strap about the wrist, the used may be provided with a handy cigarette lighter. The invention will be of service to vehicle drivers, aviators, fishermen, and others having active use of both hands.

The container 31 is provided with a fuel filler opening 31a which is closed by means of the screw plug 44a of the magnetic compass 44, which is thereby mounted on the container 31 against the top wall thereof.

It is understood that various changes in the details of construction, their combination and arrangement may be carried out within the scope of the claims which define the invention herein disclosed.

Having described my invention I claim as patentable:

1. A cigarette lighter, comprising a container for liquid fuel having an upper end wall, a tube on the upper end wall provided with a wick to receive liquid fuel from the container, an ignition wheel mounted against the upper end wall of the container and provided with edge teeth, an ignition flint engaged with the edge teeth, a housing enclosing the flint and a spring in said housing to force the flint into pressure engagement with the teeth, a lever pivotally supported at the center of the ignition wheel and provided at one end with a snuffer cup on its lower side, said snuffer cup being normally engaged with the tube, the lever having an outer arm deflected upwardly from the container and depressable to lift the snuffer cup for engagement with the tube and provided on its lower side with a pin, said wheel having a circular series of sockets to successively receive the pin, a spring for normally holding the lever so that the snuffer cup is engaged with the tube, and a spring disposed under the outer arm of the lever for holding the pin thereof normally disengaged from a socket of the wheel, whereby by depressing the outer lever arm to engage the pin thereon with one of the sockets and swinging the lever the ignition wheel will be turned against the flint to generate a spark to ignite fuel in the tube, said tube having a wick.

2. A cigarette lighter for use on the wrist of the user, comprising a liquid holding fuel container having an upper end wall, a toothed ignition wheel mounted to rotate flat against the upper end wall of the container, a spring pressed flint on said upper end wall to engage the teeth of the wheel, a fuel tube disposed near said flint and wheel to receive sparks generated by the turning of the wheel against said flint and provided with a wick to receive fuel from the container, a bracket mounted to turn at the center of the wheel, a lever pivoted to rock on the bracket and provided with an arm having a snuffer cup mounted on the lower side thereof to engage the tube, a spring secured at one end to the upper end wall of the container for holding said snuffer cup normally engaged with the tube, said lever having an outer arm projecting upwardly from the container and provided with a pin on its lower side, said wheel having a circular row of pin sockets concentric therewith, and a spring disposed under the outer arm of the lever to hold said pin normally disengaged from the adjacent pin socket of said wheel, whereby the ignition wheel may be turned against the flint by manually depressing said outer arm to engage

2,693,688

3

the pin thereon with one of the pin sockets and swinging said lever and wheel.

References Cited in the file of this patent

UNITED STATES PATENTS

Number	Name	Date
1,353,334	Geslani -----	Sept. 21, 1920
1,657,435	Metcalf -----	Jan. 24, 1928
2,535,529	Cherouvrier -----	Dec. 26, 1950

Number
135,985
137,025
917,017

5

4

FOREIGN PATENTS

Country	Date
Austria -----	Dec. 27, 1933
Austria -----	Apr. 10, 1934
France -----	Sept. 2, 1946