

Sept. 13, 1949.

L. R. JACOBSEN
MOBILE TELEPHONE SYSTEM

2,481,516

Filed March 22, 1946

2 Sheets-Sheet 1

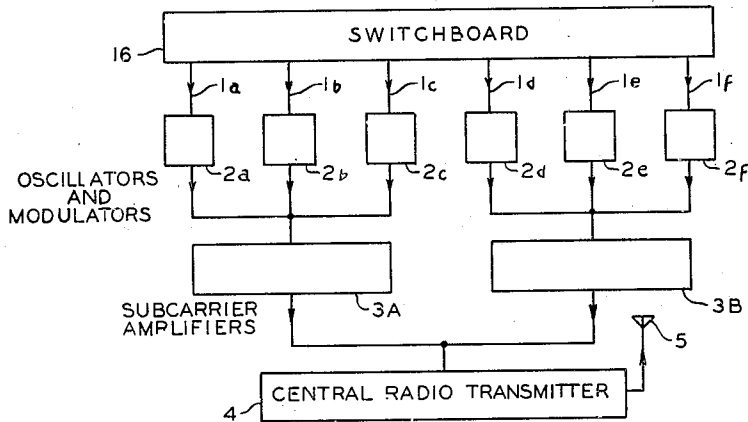

FIG. 1.

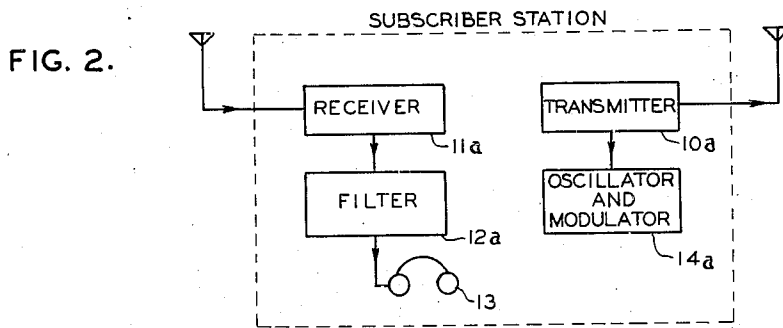

FIG. 2.

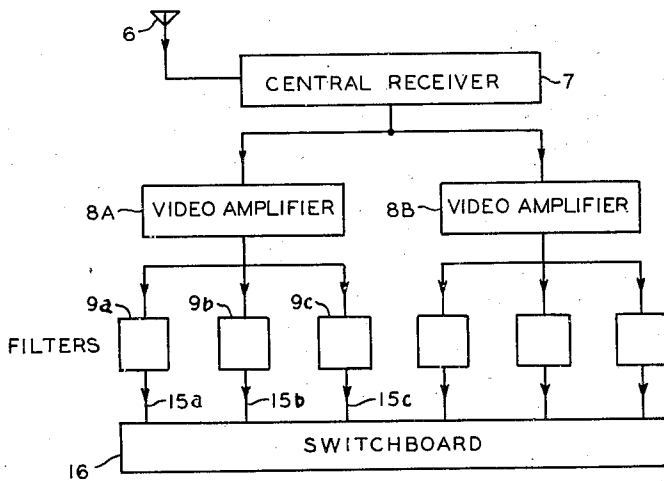

FIG. 3.

INVENTOR.
LANCE R. JACOBSEN

BY

Harry M. Saragovitz
ATTORNEY

Sept. 13, 1949.

L. R. JACOBSEN

2,481,516

MOBILE TELEPHONE SYSTEM

Filed March 22, 1946

2 Sheets-Sheet 2

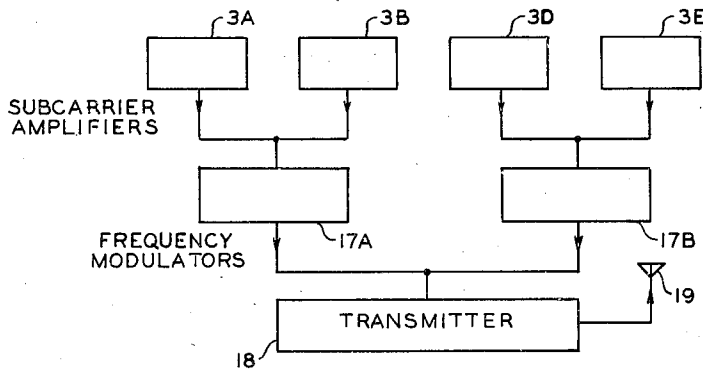

FIG. 4.

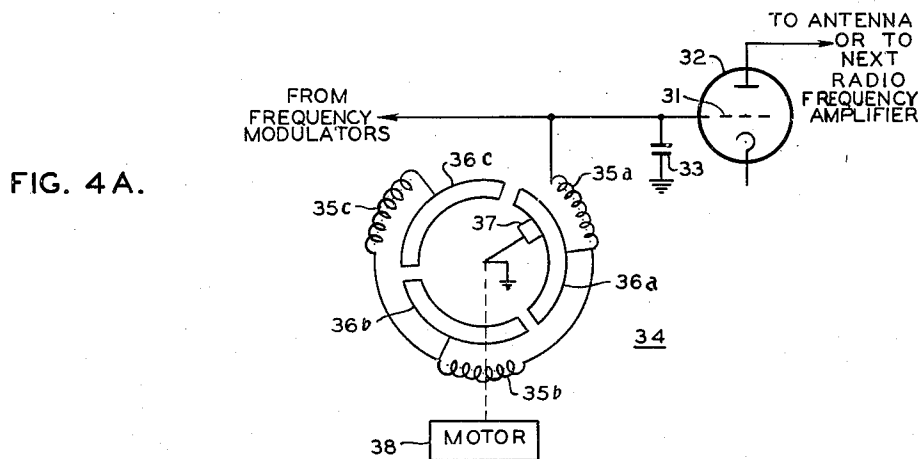

FIG. 4A.

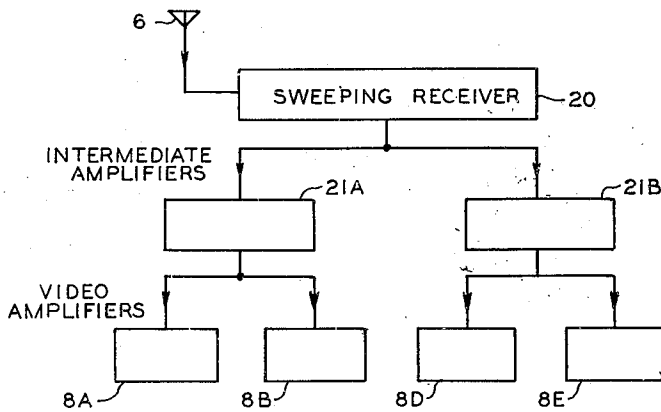

FIG. 5.

INVENTOR.
LANCE R. JACOBSEN

BY

Harry M. Saragovitz
ATTORNEY

UNITED STATES PATENT OFFICE

2,481,516

MOBILE TELEPHONE SYSTEM

Lance R. Jacobsen, Seattle, Wash.

Application March 22, 1946, Serial No. 656,244

5 Claims. (Cl. 250-6)

(Granted under the act of March 3, 1883, as amended April 30, 1928; 370 O. G. 757)

1

The invention described herein may be manufactured and used by or for the Government for governmental purposes, without the payment to me of any royalty thereon.

My invention relates to a multi-channel radio system for voice communication, which may perform the functions of a multi-subscriber telephone system. Because of the radio links employed the subscriber may be mobile within the range of coverage of the radio waves. The channels to the separate subscribers are isolated on a basis of frequency selection. Provision is made for the connection of my mobile system with the commercial wire line telephone systems. The same degree of privacy is preserved as in normal telephone subscriber systems.

It is a purpose of my invention to provide a mobile telephone system having radio links.

It is another purpose of my invention to provide a mobile telephone system with arrangement for interconnecting it with a wire line telephone system.

It is another purpose of my invention to provide a multi-channel radio transmission and reception system.

It is another purpose of my invention to provide a system of combined amplitude and frequency modulation by which a multiplicity of voice messages may be impressed and transmitted over a single carrier.

It is another purpose of my invention to provide a system of communication having a multiplicity of channels in a single final amplifier and transmitting antenna and also in a single receiving antenna and receiver.

The system which is proposed is shown in block diagram in the figures as follows:

Figure 1 is a block diagram of a central transmitting station.

Figure 2 is a block diagram of a subscriber station.

Figure 3 is a block diagram of a central receiving station.

Figure 4 shows a modification of my invention incorporating a multi-principal carrier system in the central transmitter.

Figure 4A shows one example of a system for sweep tuning the transmitter.

Figure 5 shows a modification of my invention incorporating a multi-principal carrier system in the central receiver.

The feature of my mobile telephone system which makes possible the multiplicity of channels is the system of modulation, which I shall now explain.

2

Consider a principal radio carrier of 300 megacycles frequency. Now frequency modulate this principal carrier by a subcarrier of 80 kilocycles frequency. Let the normal frequency shift of the principal carrier be ± 50 kilocycles for normal amplitude of the subcarrier. Now let the normal subcarrier be amplitude modulated by voice frequencies in the range 250-3000 cycles. For 100 per cent modulation the amplitude of the 80 kilocycle subcarrier will vary from zero to twice normal. The corresponding limiting frequency shifts produced in the principal carrier will be zero and ± 100 kilocycles. It is also possible to superpose on the 300 megacycle principal carrier another subcarrier of 86 kilocycles similarly modulated by voice frequencies in the range 250-3000 cycles. Each subcarrier and its attendant sidebands of amplitude modulation will by itself occupy a band width of 6000 cycles.

It is well-known in the art of frequency modulation that for a carrier with several superposed frequency modulations the band width which must be passed should be considerably in excess of the highest frequency of the modulation superposed. Thus for a maximum subcarrier of 99 kilocycles a band width about the principal carrier of 200,000 to 400,000 kilocycles would probably be adequate, and in the case of the 300 megacycle principal carrier proposed this band width could be very easily handled in the ultra high frequency radio channels.

Structure to perform the above functions is shown in Figure 1, which shows a central transmitting station. Audio signals are received in the separate audio lines or channels 1a, 1b, 1c, etc., coming from switchboard 16. These lines each lead to a separate oscillator and modulator, 2a, 2b, 2c, etc. These oscillators are each on a separate subcarrier frequency 48, 54, 60 kilocycles, etc. with a frequency separation of six kilocycles. Each carrier is amplitude modulated by its own audio signal. The modulated carriers from the oscillators and modulators 2a, 2b, 2c, etc., are combined and amplified together in subcarrier amplifier 3A. Because each signal on subcarrier is contained in a separate band, the signals are not confused in subcarrier amplifier 3A. The number of channels which can be accommodated is dependent on the pass band of the subcarrier amplifier 3A. For an amplifier passing 45 to 99 kilocycles, nine channels six kilocycles apart in carrier frequency and six kilocycles broad may be accommodated.

The output of amplifier 3A is applied to radio transmitter 4 as modulation. In radio transmit-

3

ter 4 this modulation frequency modulates the principal carrier. The output is radiated from antenna 5.

In order to accommodate more audio channels 1*d*, 1*e*, 1*f*, etc., additional oscillators and amplifiers are provided for them, 2*d*, 2*e*, 2*f*, etc. These oscillators are respectively on nine additional frequencies in the band 99-153 kilocycles. Their outputs are combined and amplified in subcarrier amplifier 3B, the pass band of which may be considered as 99-153 kilocycles. The output of amplifier 3B, as well as that of amplifier 3A, is applied as modulation on the carrier in radio transmitter 4. The number of subcarrier amplifiers which may apply additional subcarriers and the number of voice channels which may be thus passed through transmitter 4 and antenna 5 is very large in view of the high frequency of the principal carrier, 300 megacycles.

The signal from antenna 5 is broadcast and is received on all the receivers at the subscriber stations, one of which is shown in Figure 2. The subscriber receiver 11*a* is a frequency modulation receiver and is fixed-tuned to the frequency of the principal carrier from the central transmitter. The signal after passing the discriminator of receiver 11*a* will reproduce the modulating frequencies, namely the subcarriers. This signal is passed to a filter 12*a* which has a band width of six kilocycles and a center frequency equal to that of the subcarrier from oscillator 2*a*. Accordingly filter 12*a* selects from all the subcarriers reproduced by receiver 11*a* just one along with its attendant side bands of modulation, and that signal only is passed along with the voice modulation which it carries. This signal is amplified and detected in filter 12*a* and passed to the telephone receiver 13*a*, where the voice tones are reproduced.

It is thus seen how a voice communication from a particular channel 1*a* is transmitted to a particular receiver 13*a* of a particular subscriber station by radio.

It is apparent that for each subscriber there must be a separate audio channel 1*a*, 1*d*, etc. Insofar as calling a subscriber is concerned, channels 1*a*, 1*d*, etc., may be ordinary lines of a normal subscriber telephone system, with the restriction that ringing should be done by a low frequency alternating current rather than by direct current. Means for such modification are well known in the art.

The apparatus for responding to a call from the central station or initiating a call to the central station from the subscriber's station will now be described.

The subscriber's calling signal or voice (as the case may be) is received in oscillator and modulator 14*a*, Figure 2, which is similar to the oscillators and modulators 2*a*, 2*b*, etc., and the calling signal or voice signal is impressed as amplitude modulation on a subcarrier generated therein. For convenience this subcarrier may be thought of as having the frequency of filter 12*a*, though a somewhat different frequency might be preferable. This amplitude-modulated subcarrier is then impressed on a principal carrier in transmitter 10*a* and transmitted. The frequency of the principal carrier of the subscribers' transmitters is common to all but is sufficiently remote from the frequency of the central transmitter so that it does not interfere with reception in the subscribers' receivers.

The signals from all the subscribers are then received together on a single central antenna 6

4

and central receiver 7 at the central station shown in Figure 3. The discriminator of receiver 7 reproduces the subcarriers as amplitude vibrations with amplitude modulation. These are passed to a bank of video amplifiers 8A, 8B, etc. where they are amplified in groups, the number of subcarriers being amplified in each video amplifier being determined by the pass band of the amplifier.

From each video amplifier the signals are passed to a bank of filters 9*a*, 9*b*, 9*c*, etc. These filters are similar to the filter 12*a*, that is, each filter passes only a single selected subcarrier with its attendant side bands. In these filters 9*a*, 9*b*, 9*c*, etc. the subcarrier is demodulated and the voice or calling code frequencies are reproduced. These signals are put upon the wire lines 15*a*, 15*b*, 15*c*, etc. These lines may be handled as incoming lines of a normal subscriber telephone system, and pass to switchboard 16.

Thus there has been shown means for transmitting speech and call signals from a central station to a multiplicity of mobile stations and for transmitting speech and call signals from a multiplicity of mobile stations to a central receiving station with satisfactory isolation of the channels to and from each station.

The wire part of the system and the switchboard 16 are normal except that for each radio subscriber's station there is a pair of lines in the switchboard, rather than the single line of all wire systems. One line of a pair carries speech and signal to the subscriber, the other carries speech and signal from the subscriber. The two lines are switched together. In setting up the connection between two subscribers' stations the incoming line from one station is connected to the outgoing line to the other station and vice versa.

The switchboard 16 may be used also to connect wire telephone subscribers with radio subscribers.

In order to increase still further the number of subscribers which my mobile telephone system can accommodate I have introduced the modification shown in Figure 4 for a multi-principal carrier system. In this system a multiplicity of principal carriers is provided, thus increasing the number of possible subscribers in the ratio of the number of principal carriers. In this system a principal carrier of 300 megacycles is generated in frequency modulator 17A, a principal carrier of 302 megacycles is generated in frequency modulator 17B, and so on for a series of frequency modulators. In frequency modulator 17A the signals from a bank of subcarrier amplifiers 3A, 3B, etc. (amplitude modulated with voice), are impressed as frequency modulation on the 300 megacycle principal carrier just as before and then further amplified together with similar signals from frequency modulator 17B and from other frequency modulators in a sweep-tuned or sweeping radio transmitter 18 and radiated from sweeping antenna 19.

In exactly similar fashion voice-modulated subcarriers from subcarrier amplifiers 3D, 3E, etc., are impressed as frequency modulation in frequency modulator 17B on a 302 megacycle carrier, and this modulated carrier is passed to sweeping radio transmitter 18 and radiated from sweeping antenna 19.

It may be seen that the subcarriers in amplifiers 3A, 3B, etc. may duplicate the frequencies used in subcarrier amplifiers 3D, 3E, since the signals of one bank are sufficiently isolated from

5

those of any other bank by being on different principal carriers.

For a large number of principal carriers sweeping radio transmitter 18 and sweeping antenna 19 may be progressively tuned automatically through the band of principal frequencies. This is done at a rate rapid compared with the highest voice frequencies to be transmitted.

Figure 4A shows the input circuit to one stage of radio frequency amplification in sweeping radio transmitter 18, by means of which it may be progressively tuned automatically through a band of frequencies. This stage receives the signal from the frequency modulators and its output goes either to the next stage or to the antenna.

A continuously tuned tank circuit is shown connected to the grid 31 of radio frequency amplifier tube 32. It consists of condenser 33 in parallel with variable inductor 34. Variable inductor 34 consists of a number of coil sections 35a, 35b, and 35c. Each coil section is connected in series with the next coil section and the points of junction are connected to a commutator segment. Thus coil section 35a has one end connecting to the grid 31 and the other end to coil section 35b. The junction point connects with commutator segment 36a. The junction of coil sections 35b and 35c connects with commutator segment 36b and the other end of coil section 35c connects with commutator segment 36c.

Brush 37 is rotated by motor 38 to contact each commutator segment in turn. Brush 37 is grounded and therefore in the position shown in the drawing, only coil section 35a is in parallel with condenser 33. The inductance of coil section 35a is chosen to have a value which will resonate with condenser 33 at one principal carrier frequency and thus the radio frequency amplifier tube 32 is tuned to amplify only that principal carrier frequency. As brush 37 is revolved in a clockwise direction, it comes in contact with commutator segment 36b. The inductance in parallel with condenser 33 is then that of coil section 35a and 35b in series. The inductance of coil section 35b is chosen to have a value which when added to that of coil section 35a will cause resonance at the second principal carrier frequency. Thus radio frequency amplifier tube 32 is tuned to amplify a second principal carrier frequency. Continued rotation of brush 37 in a clockwise direction causes it to contact commutator segment 36c with the consequent tuning of the radio frequency amplifier 32 to a third principal carrier frequency, in the same manner as above stated. As brush 37 continues to be rotated, it will again contact commutator segment 36a and the radio frequency amplifier 32 will be again tuned to selectively amplify the first principal carrier frequency.

It is to be understood that, although only three are shown, as many coil sections and commutator segments may be used as there are principal carrier frequencies. Also, another continuously tuned tank circuit such as shown, may be added to the plate circuit of radio frequency amplifier tube 32, in a manner well known in the art, and may be driven by the same motor 38. This will sharpen the overall tuning of the radio frequency amplifier. Furthermore, as many such radio frequency amplifier stages as are necessary to obtain the desired output power may be used. The frequency of the alternation of the principal carriers depends upon relative brush and commu-

6

tator segment size and the speed of rotation of motor 38. It is also to be understood that there are other well known ways to alternate the frequency radiated by a radio frequency transmitter and the embodiment shown in Figure 4A is by way of illustration only and is not to be considered as a limitation upon the invention as recited in the claims.

For a small number of principal carriers the transmitter and antenna may be fixed-tuned with a pass band width broad enough to pass all principal carriers simultaneously.

In this multi-principal carrier system, the mobile subscriber stations are as before except that the tuning of the subscriber receivers is distributed among the principal carrier frequencies from the central transmitter 18. Each subscriber receiver 11a will be tuned to the principal carrier of the frequency modulator 17A with which that subscriber's wire line 1a is associated in switchboard 16.

Similarly the transmitters of the subscriber stations are now tuned to one or another of a set of principal carrier frequencies different from the set used for transmission from the central station.

The modification of the central receiving station for my multiprincipal carrier system is shown in Figure 5.

The signals on the multiplicity of principal carriers from the subscriber transmitters 10a, etc. are all received simultaneously on antenna 6 and sweeping receiver 20 at the central receiving station. If necessary to cover the entire band of principal carriers from the subscribers, sweeping receiver 20 may sweep in tuning over the band at a rate high compared to the highest audio frequency to be received, but in general it is possible to construct a receiver with a much higher pass band width than it is to construct a transmitter in the same range, so that the sweeping feature may not be so necessary.

After conversion to intermediate frequency in receiver 20 (whether actually sweeping or fixed-tuned) the output is fed to a multiplicity of intermediate amplifiers. There will be as many different intermediate frequencies in sweeping receiver 20 as there are different principal frequencies in the subscriber transmitters 11a, etc. Each of the intermediate amplifiers 21A, 21B, etc., is tuned to one of these intermediate frequencies and rejects the others. Thus the principal carriers are separated in the intermediate stage. The outputs of the intermediate amplifiers are fed to limiters and discriminators which produce the subcarrier groups, these groups are fed to their respective video amplifiers 8A, 8B, etc., 8D, 8E, etc., just as before.

It is seen that, just as in the central transmitter each subcarrier frequency may be used once for every principal carrier frequency used, so for the subscriber transmitter the same subcarrier may be used in one subscriber transmitter having one principal carrier and again in another subscriber transmitter having another principal carrier frequency, and so on for each principal carrier employed.

By the use of single side band technique in the amplitude modulation of the subcarriers the band width of the modulated subcarrier signals may be halved and the number of subcarriers doubled with a consequent doubling of the number of subscriber stations which may be handled by given radio equipment.

Many changes and substitutions in the appara-

thus may be made without departing from the spirit of my invention, which is limited only by the following claims.

I claim:

1. In a multisubscriber radio telephone system, a central radio transmitter station, a telephone switchboard, a multiplicity of groups of subscriber radio stations, outgoing lines from said switchboard carrying audio signals for respective subscribers to said central radio transmitter station, means for generating a plurality of distinct subcarrier frequencies each one of which is associated with one subscriber radio station in each of said groups, means at the central radio transmitter station to amplitude modulate each of the subcarrier frequencies by each of the said audio signals, means for combining the amplitude modulated subcarrier frequencies associated with a group of subscriber radio stations into a subcarrier group, apparatus for generating a plurality of distinct principal carriers, each principal carrier being assigned to one of the said groups of subscriber radio stations, means for frequency modulating each of the assigned principal carriers by the subcarrier group assigned to the same radio subscriber station group, means for alternately radiating said frequency modulated principal carriers at a rate that is high when compared with the highest audio frequency sought to be transmitted, receiving means at said subscriber radio stations to receive said alternately radiated principal carriers, central radio receiving station means, communication means between said subscriber radio stations and said central receiving radio station means, incoming lines from said central receiving radio station to said telephone switchboard.

2. In a multisubscriber radio telephone system as set forth in claim 1, wherein said receiving means at said subscriber radio stations comprises, tuning means to select the principal carrier assigned to said group of subscriber radio stations, means to demodulate the assigned principal carrier, means to filter from the wave derived from the demodulation the subcarrier frequency assigned to the subscriber radio station, means to demodulate said subcarrier of the audio signal amplitude modulated upon it, means to transduce said audio signal into acoustical energy.

3. In a multisubscriber radio telephone system as set forth in claim 1, wherein said communication means between said subscriber radio stations and said central receiving radio station comprises means to transduce acoustical energy to audio frequency, means to generate a subcarrier of the frequency assigned to the subscriber radio station, means to amplitude modulate said subcarrier by the said audio frequency, means to generate a principal carrier different from the principal carrier received, these subscriber radio station generated principal carriers being assigned similarly, one to each group of subscriber radio stations and of a different frequency than the principal carrier received by said group, means to frequency modulate the said principal carrier by the amplitude modulated subcarrier frequency, means to transmit said frequency

modulated principal carrier to the central receiving radio station means.

4. In a multisubscriber radio telephone system as set forth in claim 1, wherein said central radio receiving station means comprises broad band receiving means to receive all the frequency modulated principal carriers from the subscriber radio stations, means to heterodyne the received principal carriers with a locally generated oscillation, a plurality of intermediate frequency amplifiers each tuned to an intermediate frequency assigned to each one of said groups of radio subscriber stations, means to feed the heterodyned wave to the plurality of intermediate frequency amplifiers, means to demodulate the respective intermediate frequency amplifier outputs of their respective subcarrier groups, filter means to separate the subcarrier groups into the respective subcarriers assigned to each subscriber radio station, means to demodulate the subcarriers of their audio frequencies and means to connect the said audio frequencies in to the telephone switchboard.

5. In a multisubscriber radio telephone system as set forth in claim 4, wherein said central radio receiving station means comprises tuned receiving means, means to alternate said tuned receiving means through the principal carrier frequencies transmitted by said subscriber radio station groups at a rate that is high when compared with the highest audio frequency transmitted, means to heterodyne the received principal carriers with a locally generated oscillation, a plurality of intermediate frequency amplifiers each tuned to an intermediate frequency assigned to each one of said groups of radio subscriber stations, means to feed the heterodyned wave to the plurality of intermediate frequency amplifiers, means to demodulate the respective intermediate frequency amplifier outputs of their respective subcarrier groups, filter means to separate the subcarrier groups into the respective subcarriers assigned to each subscriber radio station, means to demodulate the subcarriers of their audio frequencies and means to connect the said audio frequencies in to the telephone switchboard.

LANCE R. JACOBSEN.

REFERENCES CITED

The following references are of record in the file of this patent:

UNITED STATES PATENTS

Number	Name	Date
2,092,442	Colwell	Sept. 7, 1937
2,104,012	Armstrong	Jan. 4, 1938
2,233,183	Roder	Feb. 25, 1941
2,284,247	Bagnall	May 26, 1942
2,298,409	Peterson	Oct. 13, 1942
2,329,519	Dixon	Sept. 14, 1943
2,378,298	Hilferty	June 12, 1945
2,390,641	Chatterjea	Dec. 11, 1945
2,420,374	Houghton	May 13, 1947
2,421,017	Deloraine et al.	May 27, 1947
2,421,727	Thompson	June 3, 1947
2,433,343	Chatterjea et al.	Dec. 30, 1947