



US00D864831S

(12) **United States Design Patent**
Umehara et al.

(10) **Patent No.:** **US D864,831 S**

(45) **Date of Patent:** **** Oct. 29, 2019**

(54) **WHEEL**

(71) Applicant: **American Honda Motor Co., Inc.**,
Torrance, CA (US)

(72) Inventors: **Masaru Umehara**, Miyoshi-machi (JP);
Tadashi Nakano, Fujimino (JP)

(73) Assignee: **American Honda Motor Co., Inc.**,
Torrance, CA (US)

(**) Term: **15 Years**

(21) Appl. No.: **29/657,043**

(22) Filed: **Jul. 18, 2018**

(51) **LOC (12) Cl.** **12-16**

(52) **U.S. Cl.**
USPC **D12/209**

(58) **Field of Classification Search**
USPC D12/204–213
CPC B60B 7/00; B60B 7/02; B60B 7/04; B60B
7/01; B60B 7/06; B60B 3/02; B60B 3/04;
B60B 3/06; B60B 3/10; B60B 1/00;
B60B 1/08; B60B 1/10; B60B 1/12
See application file for complete search history.

(56) **References Cited**

U.S. PATENT DOCUMENTS

D351,821 S *	10/1994	Oka	D12/209
D367,461 S *	2/1996	Chung	D12/209
D400,154 S *	10/1998	Noriega	D12/209
D415,091 S *	10/1999	Echazabal	D12/209
D420,638 S *	2/2000	Herrera	D12/209
D421,591 S *	3/2000	Chrysanto	D12/209
D427,556 S *	7/2000	Wang	D12/209
D430,842 S *	9/2000	Chinellato	D12/209
D435,004 S *	12/2000	Noriega	D12/209

D436,338 S *	1/2001	Hussaini	D12/209
D669,833 S *	10/2012	Pollmann	D12/209
D682,761 S *	5/2013	Pollmann	D12/209
D683,681 S *	6/2013	Juergens	D12/209
D753,045 S *	4/2016	Kawaguchi	D12/209
D762,543 S *	8/2016	Hara	D12/209
D825,424 S *	8/2018	Setter	D12/209
D848,922 S *	5/2019	Tovey	D12/209

* cited by examiner

Primary Examiner — Stacia A Cadmus

(74) *Attorney, Agent, or Firm* — Arent Fox LLP

(57) **CLAIM**

The ornamental design for a wheel, as shown and described.

DESCRIPTION

FIG. 1 is a front left perspective view of a wheel showing our new design;
 FIG. 2 is a front right perspective view of the design shown in FIG. 1;
 FIG. 3 is a rear right perspective view of the design shown in FIG. 1;
 FIG. 4 is a rear left perspective view of the design shown in FIG. 1;
 FIG. 5 is a front view of the design shown in FIG. 1;
 FIG. 6 is a rear view of the design shown in FIG. 1;
 FIG. 7 is a left side view of the design shown in FIG. 1;
 FIG. 8 is a right side view of the design shown in FIG. 1;
 FIG. 9 is a top view of the design shown in FIG. 1; and,
 FIG. 10 is a bottom view of the design shown in FIG. 1.
 The broken lines shown in the figures are included for the purpose of illustrating portions of the wheel and form no part of the claimed design.

1 Claim, 10 Drawing Sheets

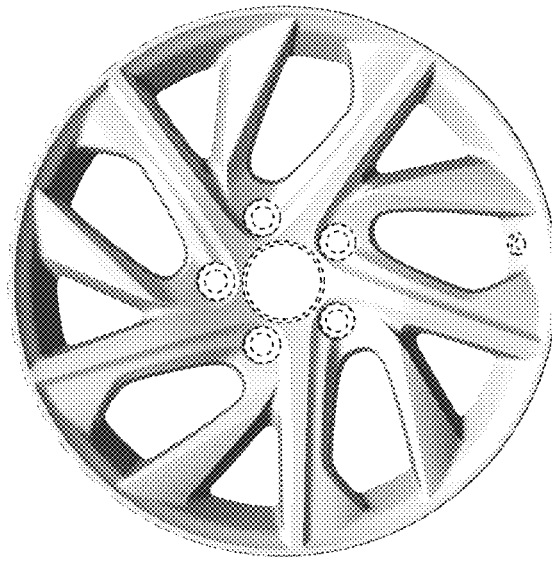
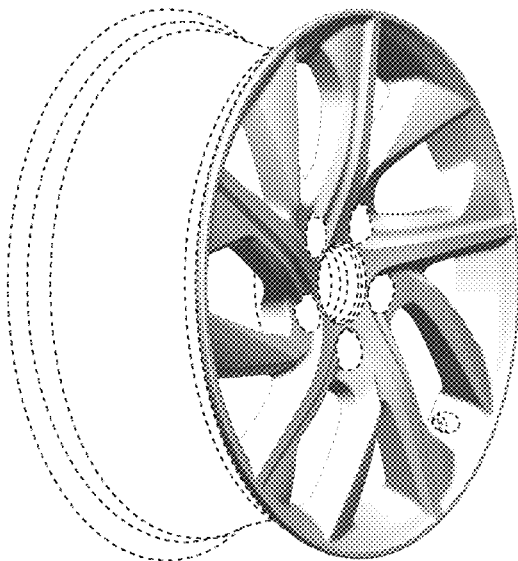

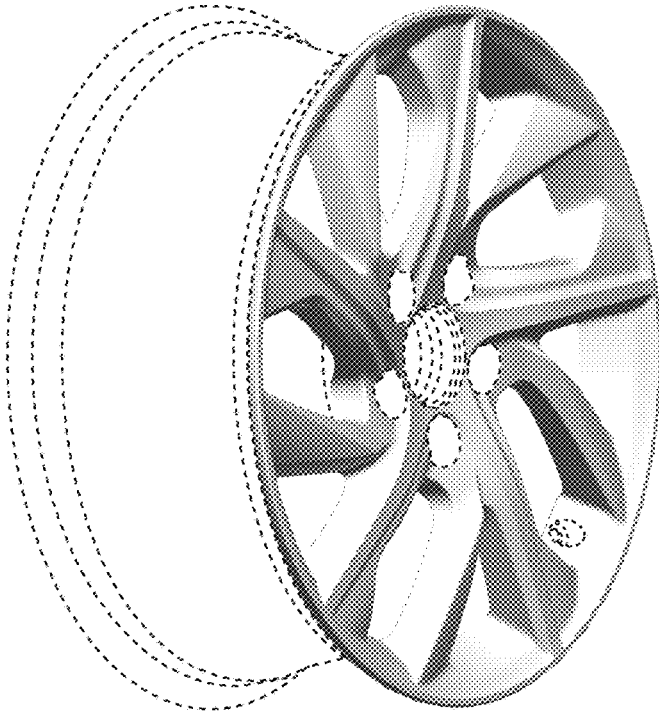

FIG. 1

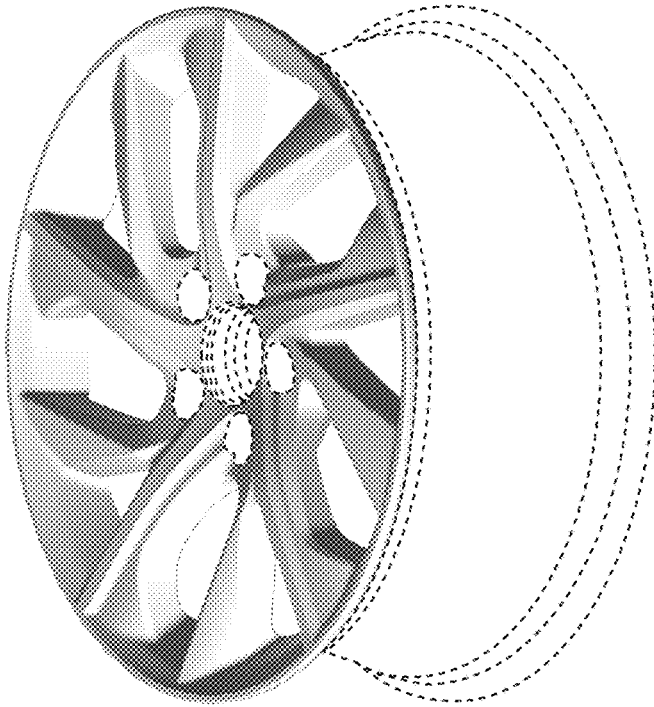

FIG. 2

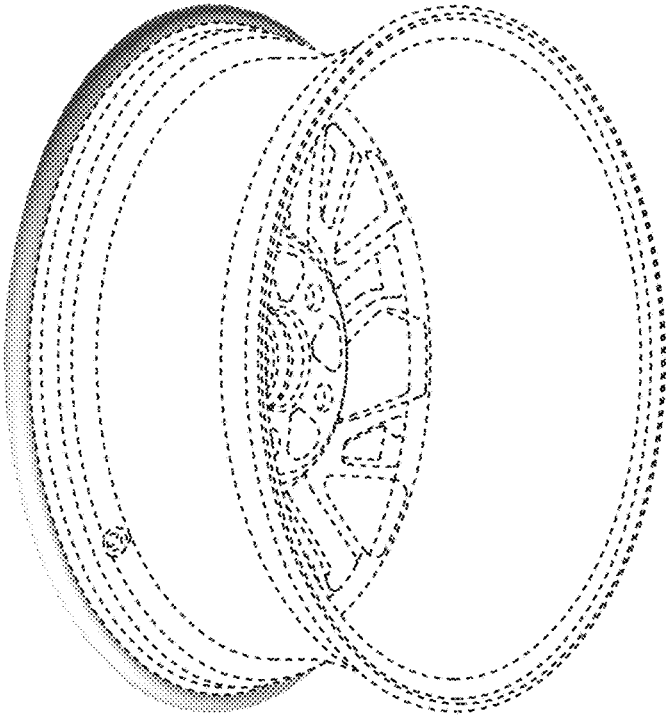

FIG. 3

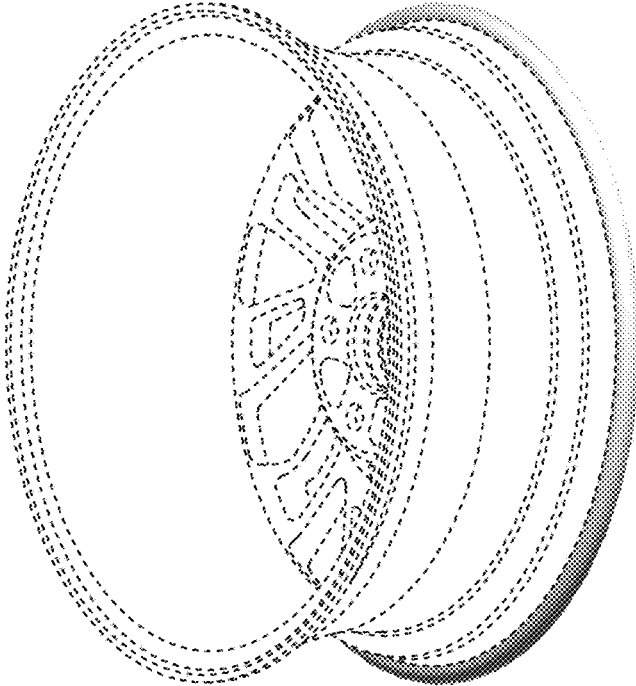

FIG. 4

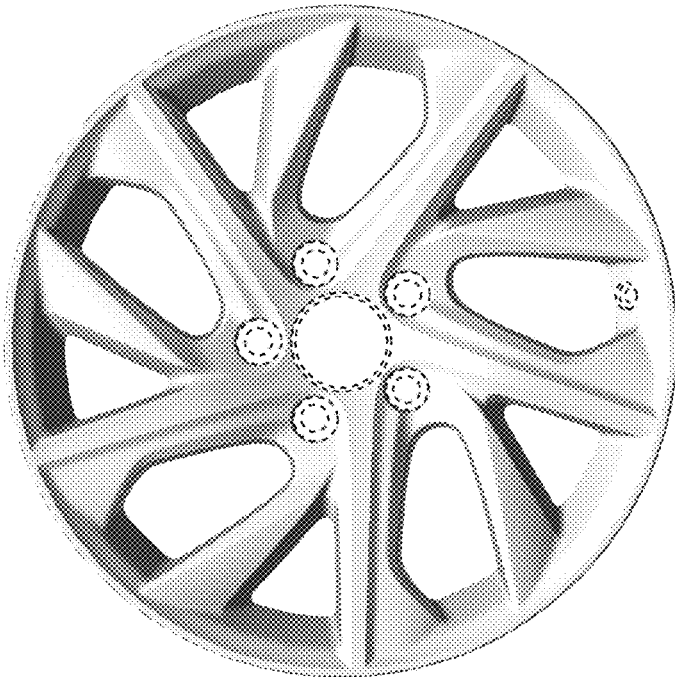

FIG. 5

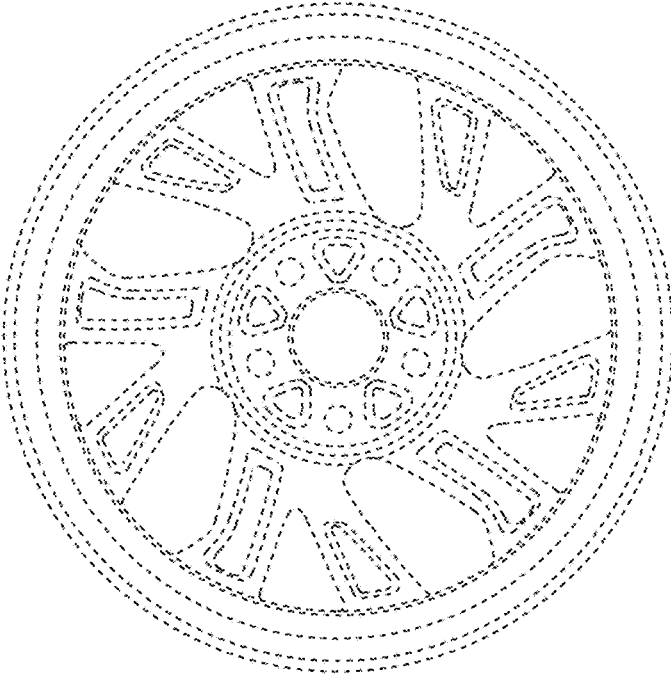

FIG. 6

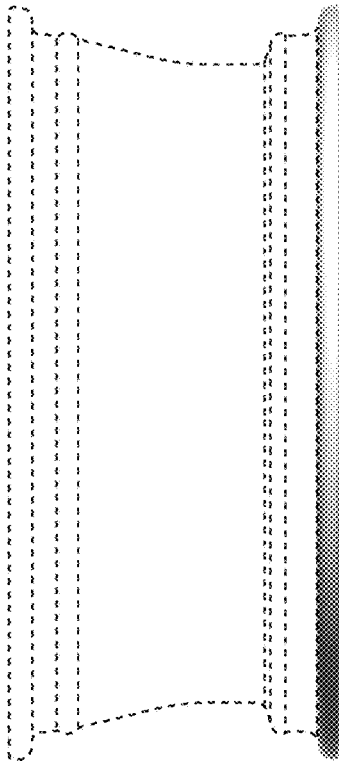

FIG. 7

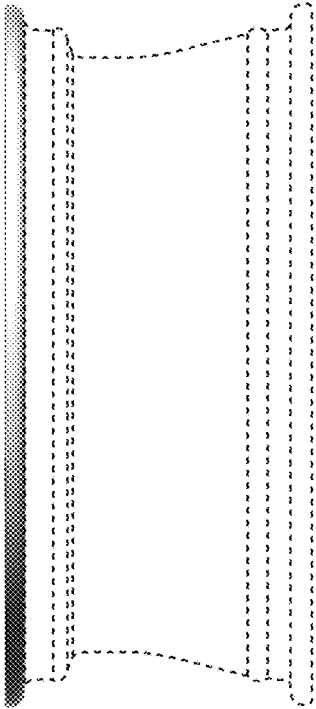

FIG. 8

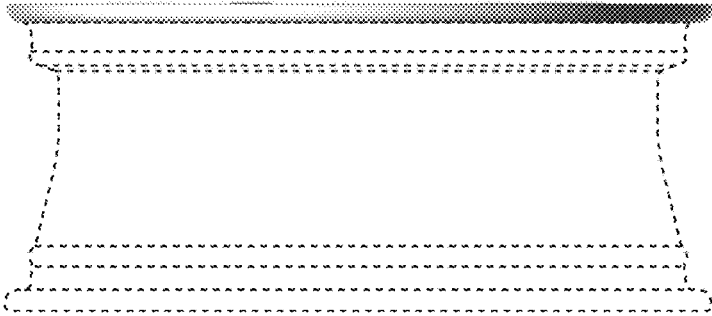

FIG. 9

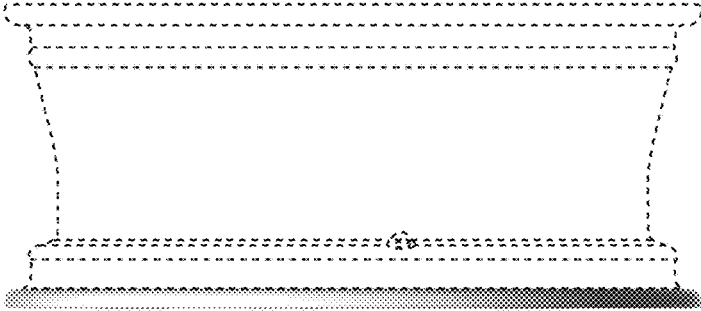

FIG. 10