



US009675170B2

(12) **United States Patent**
Klinke

(10) **Patent No.:** **US 9,675,170 B2**
(45) **Date of Patent:** **Jun. 13, 2017**

(54) **TELESCOPIC COLUMN, PREFERABLY FOR FURNITURE**

7/018 (2013.01); A47B 3/0913 (2013.01);
A47B 2019/008 (2013.01); F16M 11/26
(2013.01); F16M 11/32 (2013.01); F16M
2200/08 (2013.01)

(75) Inventor: **Norbert Klinke**, Augustenborg (DK)

(73) Assignee: **Linak A/S**, Nordborg (DK)

(*) Notice: Subject to any disclaimer, the term of this patent is extended or adjusted under 35 U.S.C. 154(b) by 314 days.

(58) **Field of Classification Search**

CPC F16M 11/26; F16M 11/24; F16M 11/32;
F16M 2200/08; A47B 9/20; A47B 9/00;
A47B 91/16; F21V 21/22; F21V 27/00
USPC 248/125.8, 188.5, 326, 333, 616
See application file for complete search history.

(21) Appl. No.: **13/508,487**

(22) PCT Filed: **Oct. 29, 2010**

(56) **References Cited**

U.S. PATENT DOCUMENTS

(86) PCT No.: **PCT/DK2010/000160**

§ 371 (c)(1),
(2), (4) Date: **May 7, 2012**

3,770,334 A * 11/1973 Weber 312/223.4
3,792,189 A * 2/1974 Stengel et al. 174/69
(Continued)

(87) PCT Pub. No.: **WO2011/063812**

PCT Pub. Date: **Jun. 3, 2011**

FOREIGN PATENT DOCUMENTS

(65) **Prior Publication Data**

US 2013/0015300 A1 Jan. 17, 2013

DE 102007030473 1/2009
WO 2004/100632 11/2004

Primary Examiner — Brian Mattei
Assistant Examiner — Taylor Morris

(30) **Foreign Application Priority Data**

Nov. 28, 2009 (DK) 2009 01264

(74) *Attorney, Agent, or Firm* — Dykema Gossett PLLC

(51) **Int. Cl.**

A47F 5/00 (2006.01)
A47F 7/00 (2006.01)
F16M 11/00 (2006.01)
F16M 13/00 (2006.01)
A47B 9/20 (2006.01)
A47B 21/06 (2006.01)
A61G 7/012 (2006.01)

(Continued)

(57) **ABSTRACT**

A telescopic lifting column (1) preferably for furniture, such as height adjustable tables and beds, and comprising at least two mutually telescopic members (2, 3, 4) and an electric drive unit (5, 10; 41, 42) for adjusting the telescopic members. The lifting column comprises a telescopic cable guiding device (22; 45, 58, 80, 103) for guiding at least one electric cable (29), where the telescopic cable guiding device extends between or in all essentials between the lower and upper end of the lifting column and is connected thereto so that the telescopic cable guiding device collaborates in the telescopic adjustment of the lifting column. Thus the cables may be guided in a protected manner.

(52) **U.S. Cl.**

CPC A47B 9/20 (2013.01); A47B 9/00
(2013.01); A47B 9/04 (2013.01); A47B 21/06
(2013.01); A61G 7/012 (2013.01); A61G

16 Claims, 9 Drawing Sheets

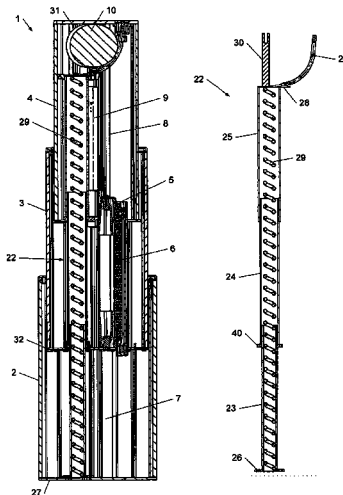

(51)	Int. Cl.								
	<i>A61G 7/018</i>	(2006.01)	4,838,258	A *	6/1989	Dryden	A61M 16/085	
	<i>A47B 9/00</i>	(2006.01)						128/204.18	
	<i>A47B 9/04</i>	(2006.01)	5,339,750	A *	8/1994	Smies	108/147	
	<i>F16M 11/26</i>	(2006.01)	6,874,500	B2 *	4/2005	Fukunaga	A61M 16/00	
	<i>A47H 1/10</i>	(2006.01)						128/203.12	
	<i>A47B 19/00</i>	(2006.01)	6,875,924	B2 *	4/2005	Porter et al.	174/69	
	<i>F16M 11/32</i>	(2006.01)	7,077,165	B2 *	7/2006	Takasaki	F16L 9/18	
	<i>A47B 3/091</i>	(2006.01)						138/108	
			7,163,184	B2	1/2007	Nielsen			
			7,183,502	B1 *	2/2007	Johnston et al.	174/480	
			7,495,359	B2 *	2/2009	Klinke et al.	310/51	
			7,506,560	B2	3/2009	Klinke			
			7,647,659	B2	1/2010	Frolik et al.			
			2006/0130713	A1 *	6/2006	Jones et al.	108/106	
			2007/0251014	A1 *	11/2007	Newkirk et al.	5/658	
			2007/0295571	A1 *	12/2007	Tong	191/12 R	
			2008/0143097	A1 *	6/2008	Canale	285/7	
			2010/0187379	A1	7/2010	Kragh et al.			
			2010/0287726	A1 *	11/2010	Cordes et al.	15/414	
									* cited by examiner
(56)	References Cited								
	U.S. PATENT DOCUMENTS								
	3,987,807	A *	10/1976	Varnell	135/66			
	4,336,798	A *	6/1982	Beran	A61M 16/1095			
						128/200.14			
	4,762,072	A *	8/1988	Boundy	A47B 21/06			
						108/50.02			

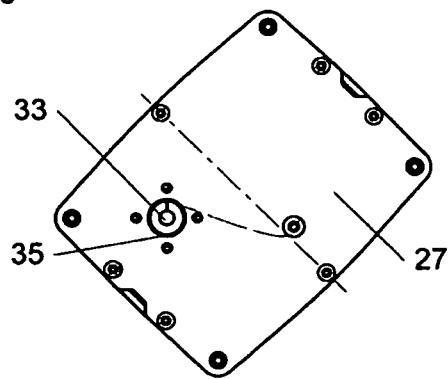
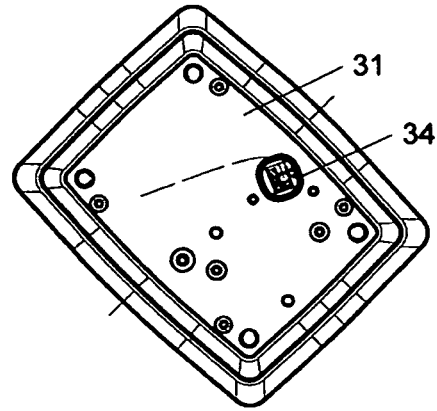
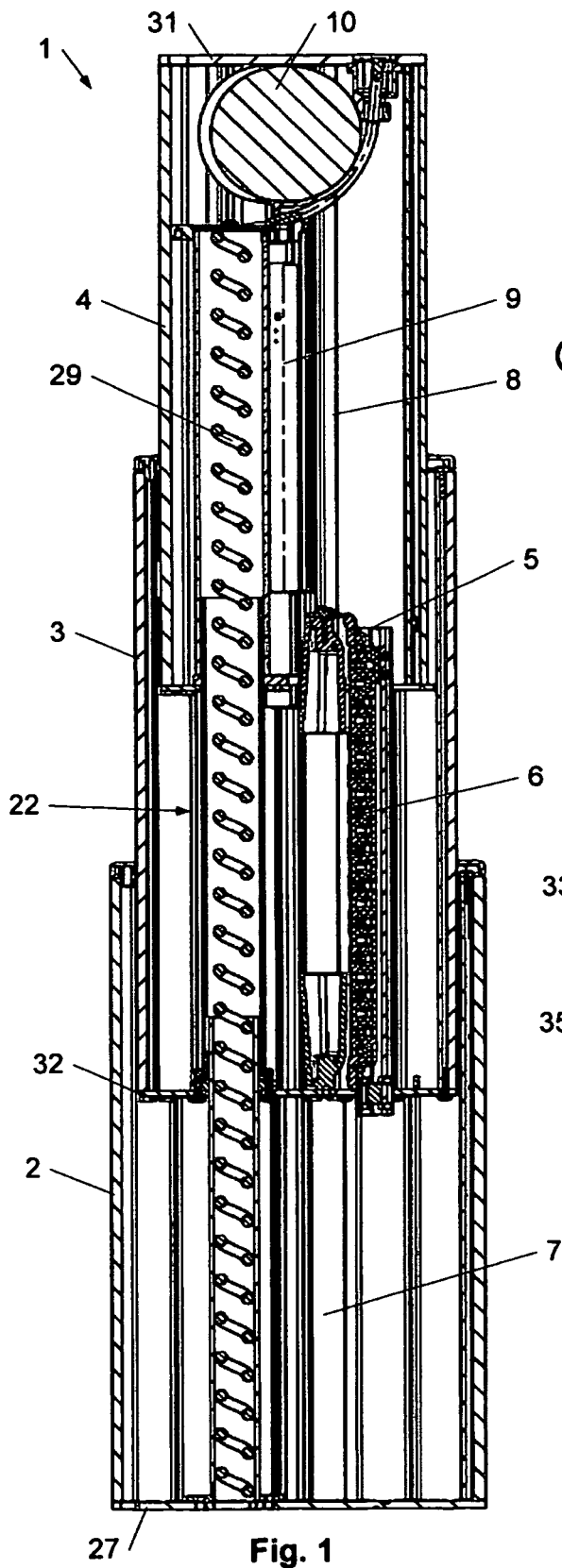

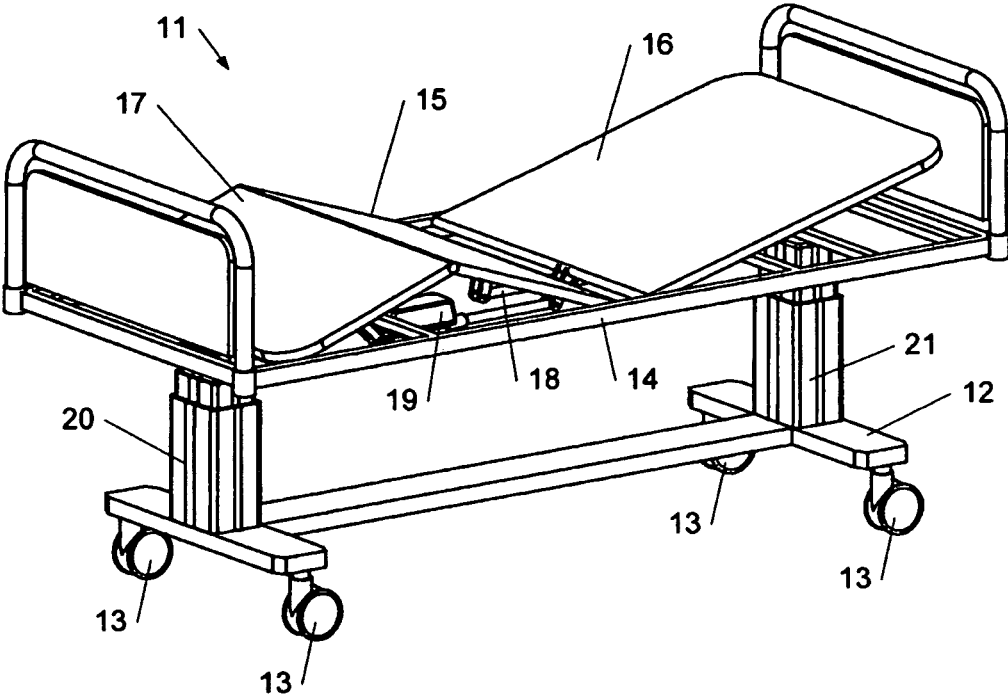

Fig. 4

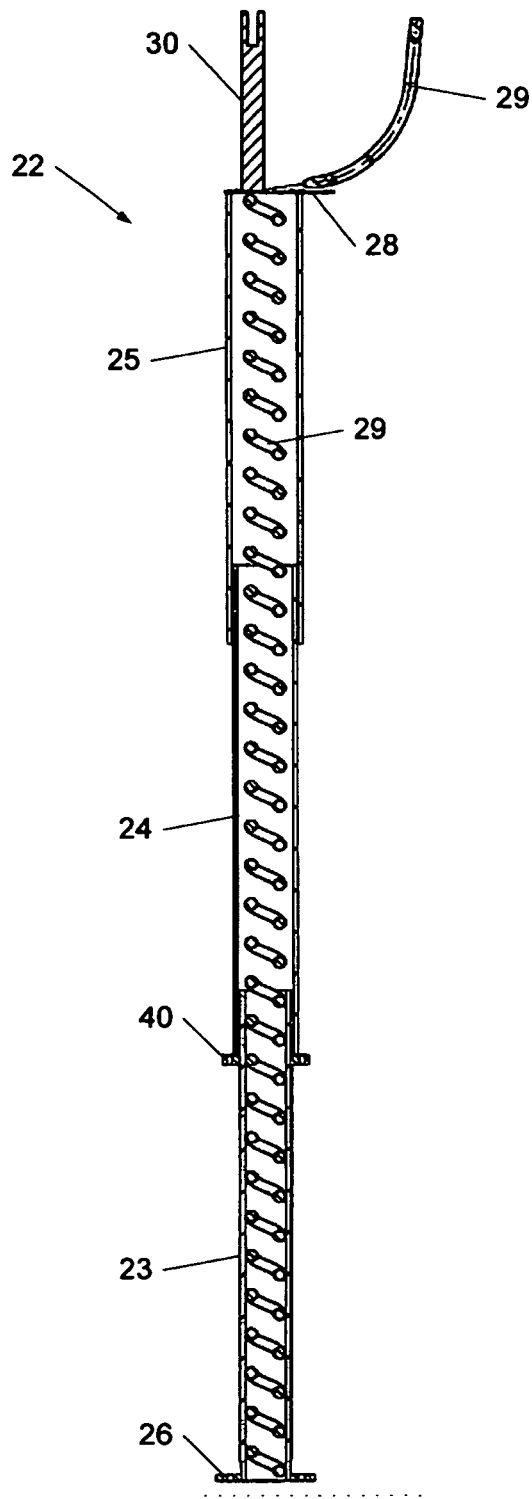

Fig. 5

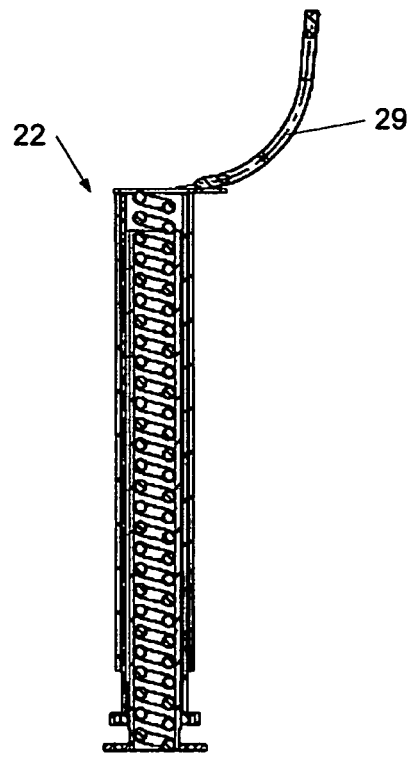

Fig. 6

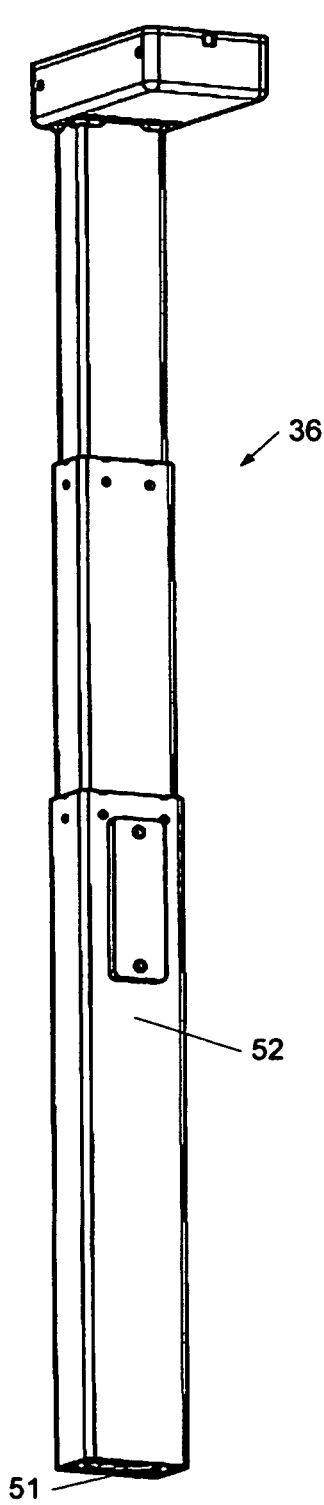

Fig. 7

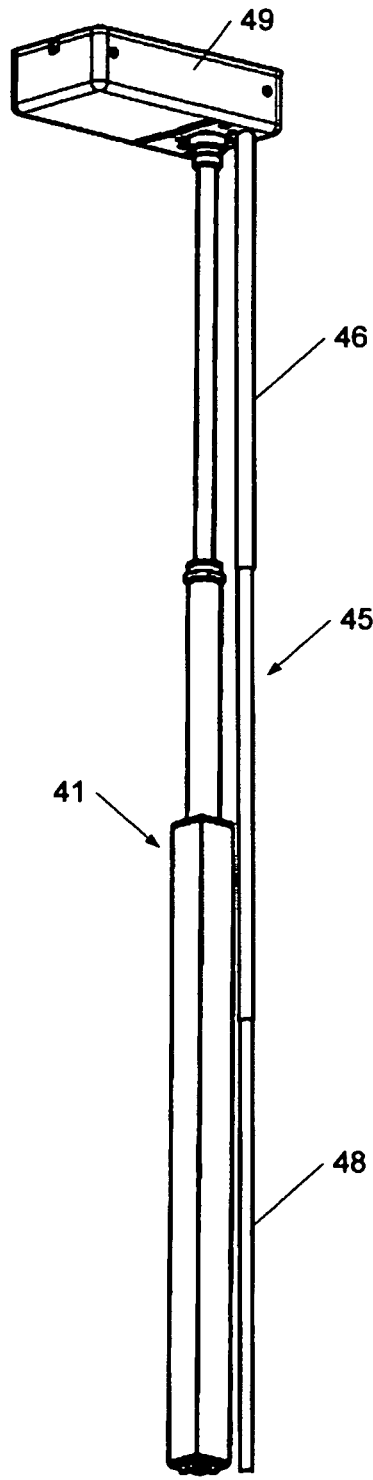

Fig. 8

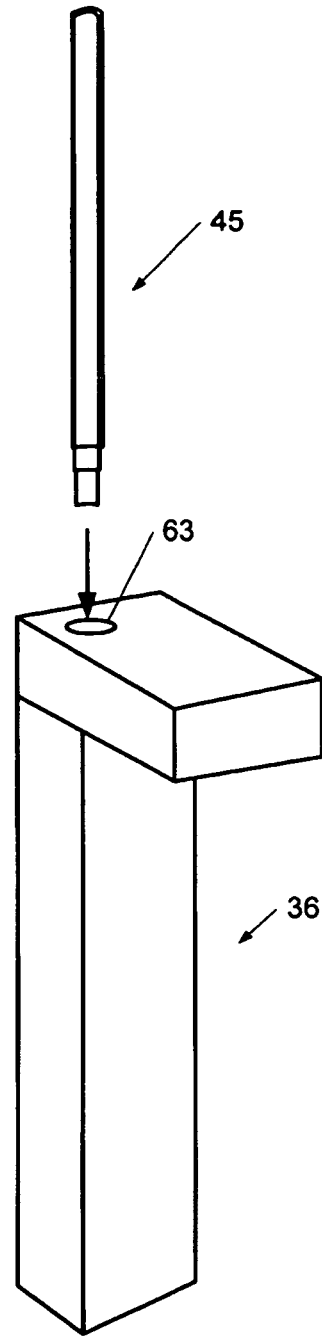

Fig. 27

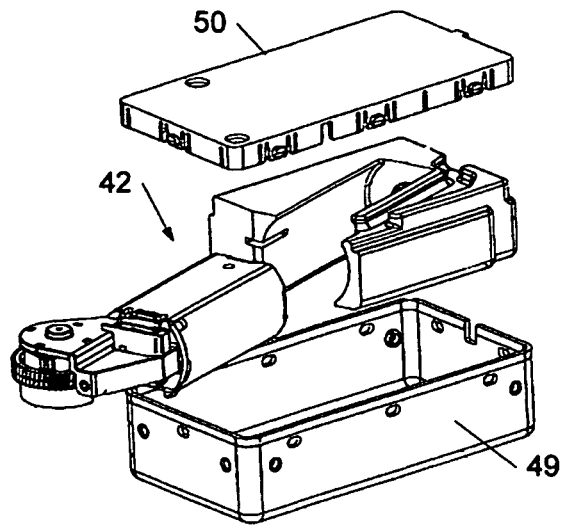

Fig. 9

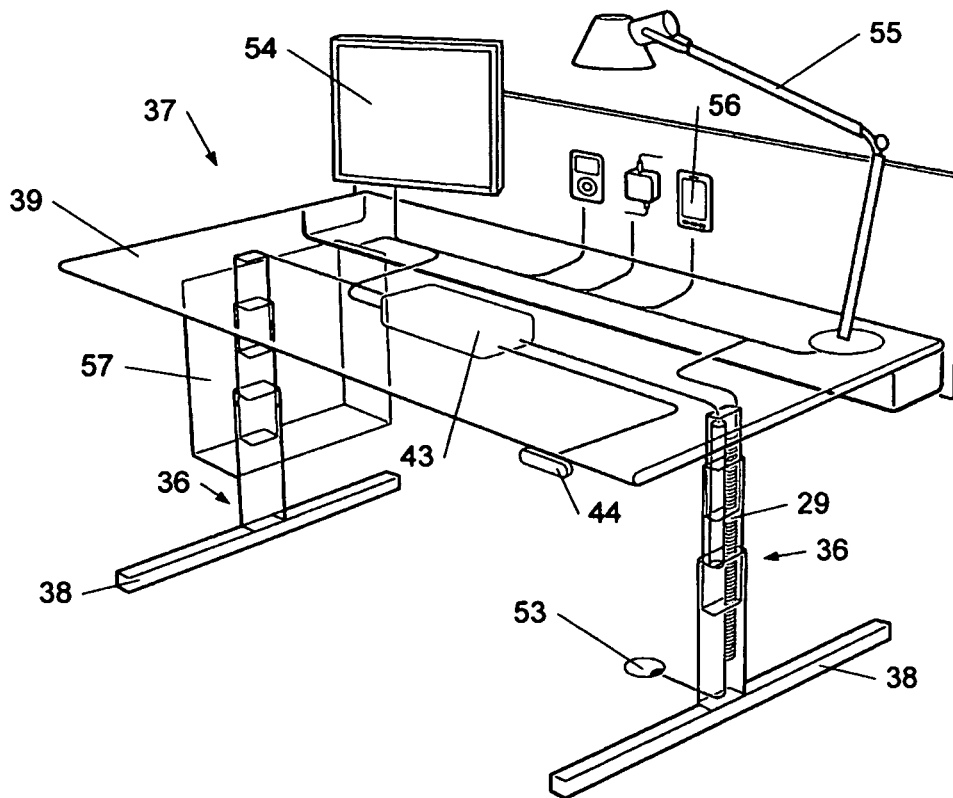
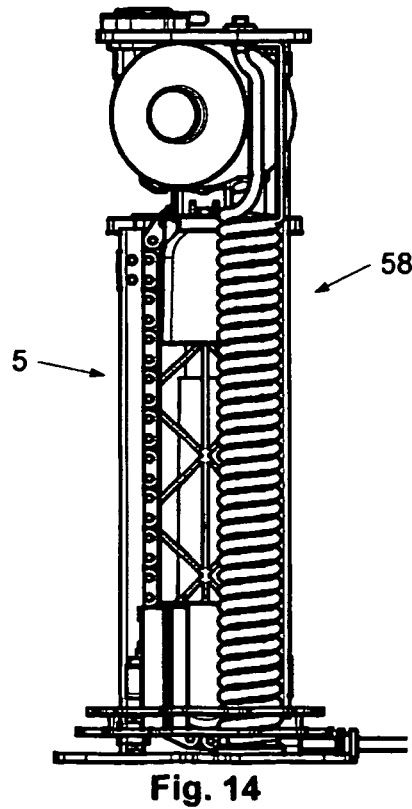
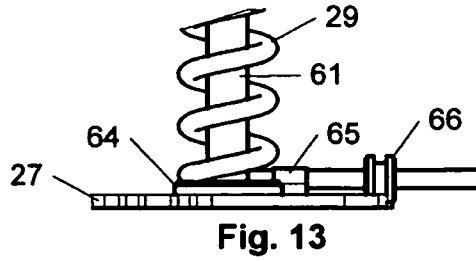
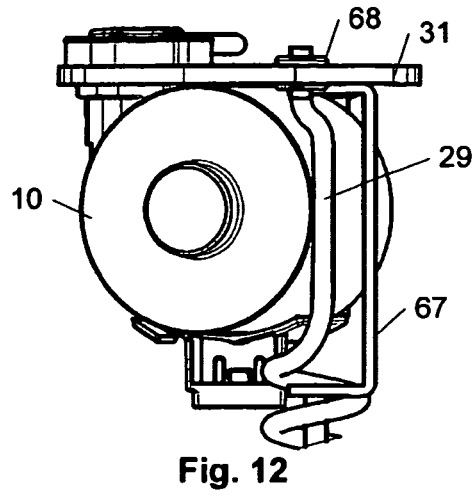
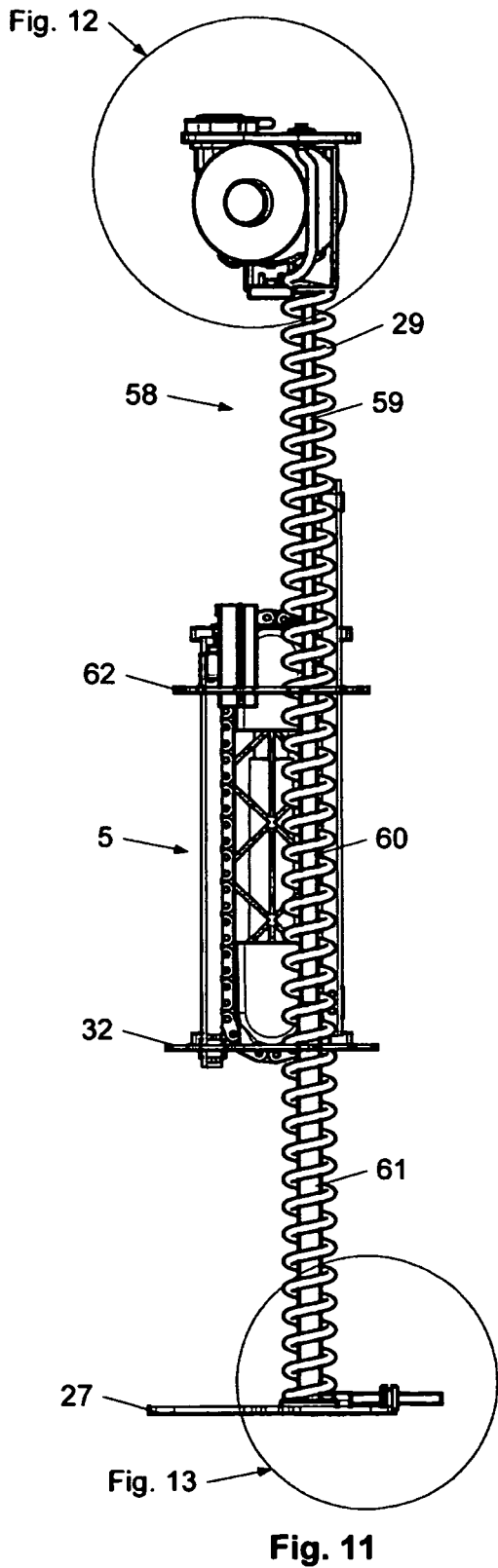

Fig. 10



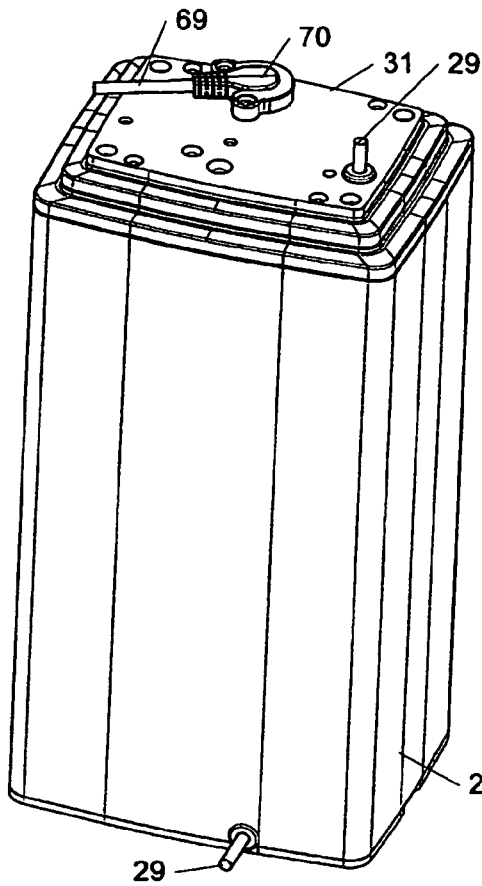

Fig. 15

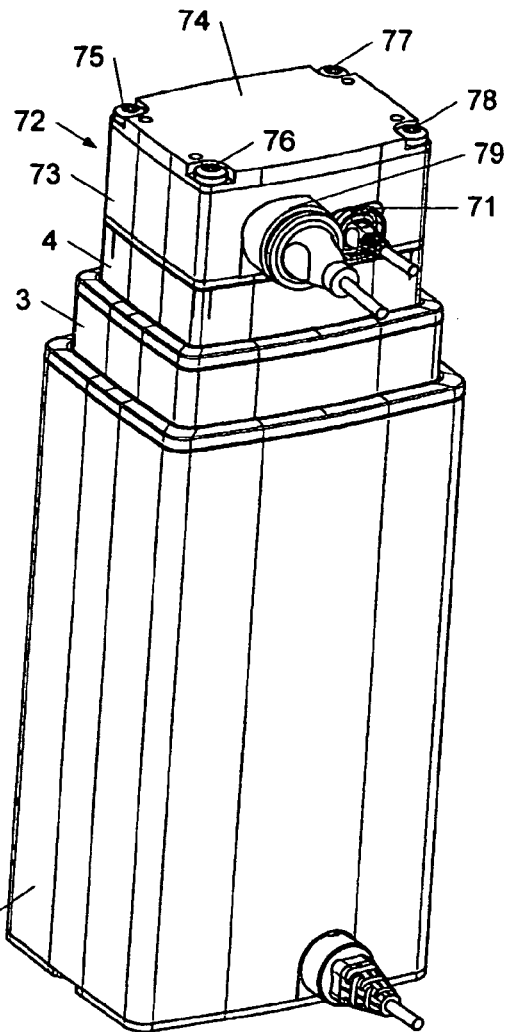

Fig. 16

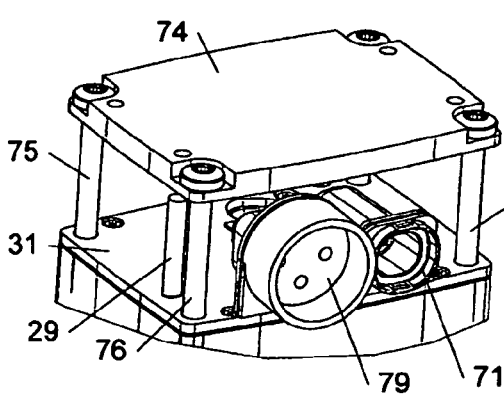

Fig. 17

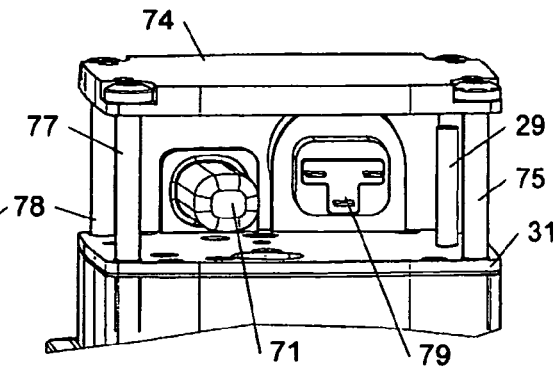

Fig. 18

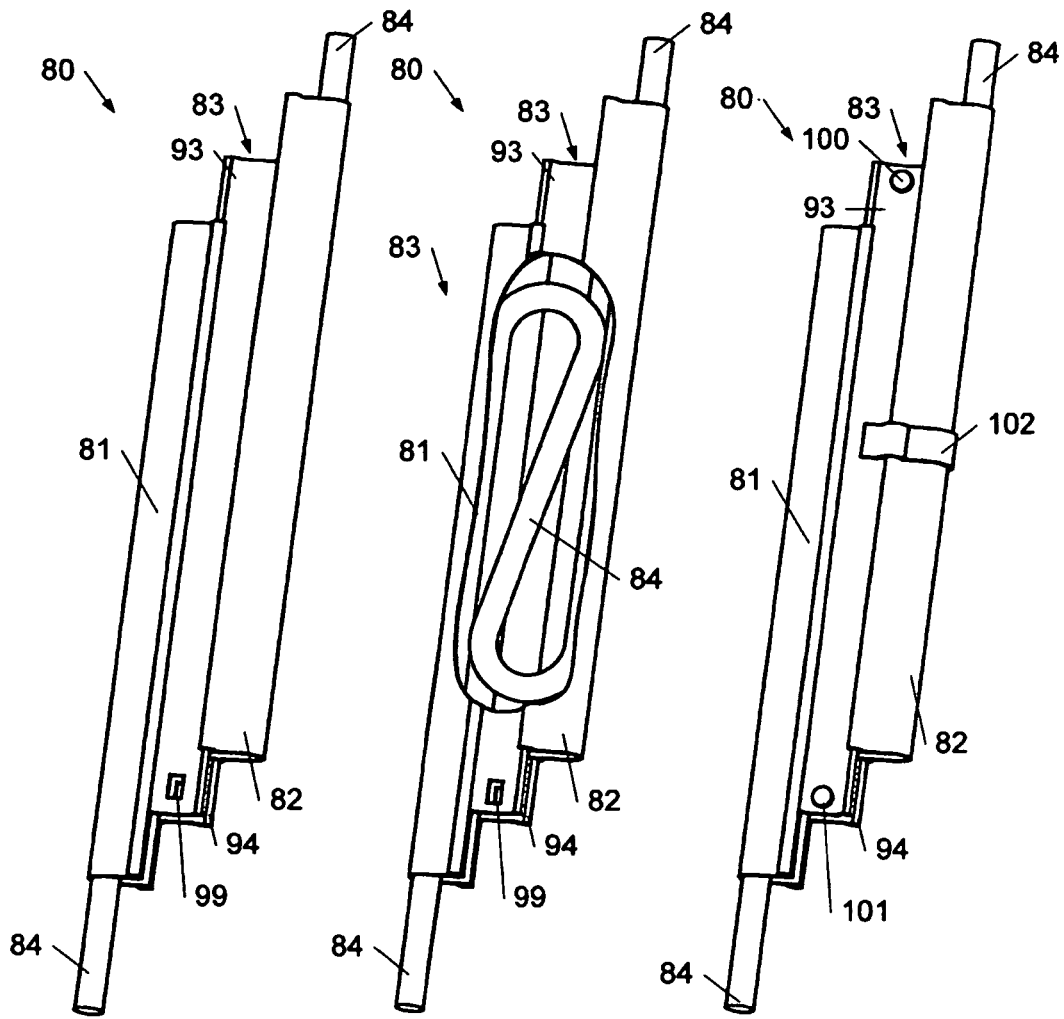

Fig. 19

Fig. 20

Fig. 21

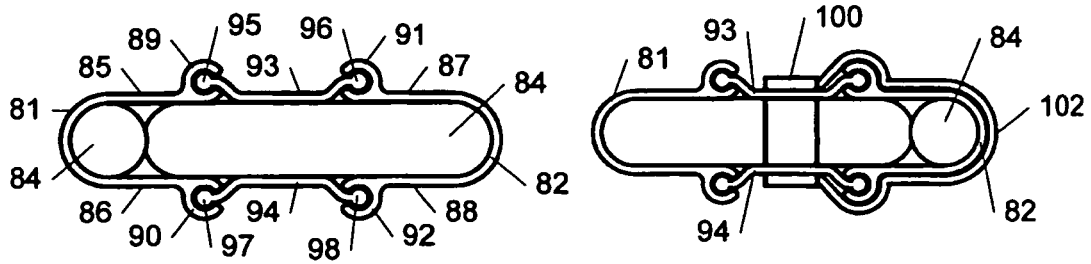

Fig. 22

Fig. 23

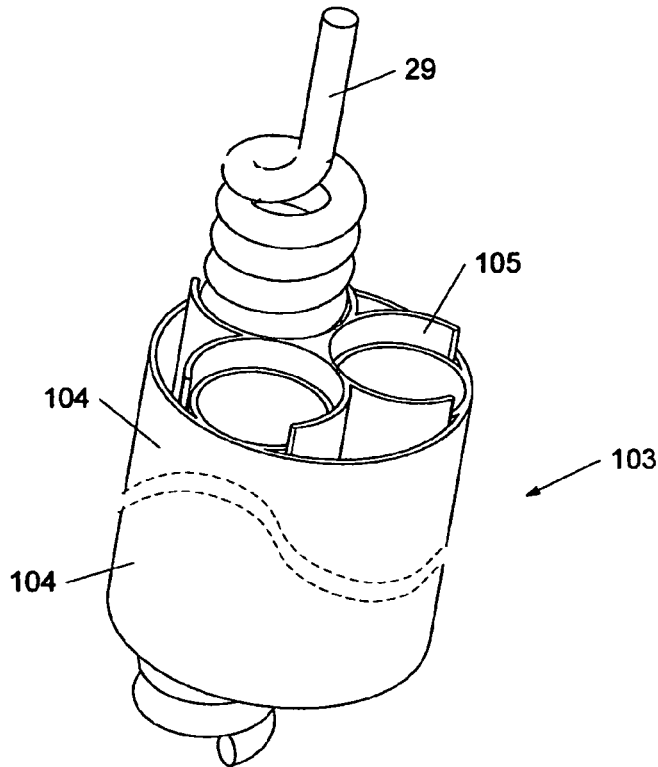

Fig. 24

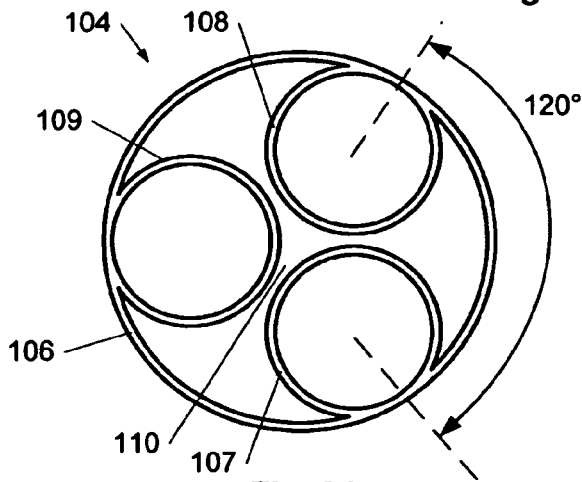

Fig. 25

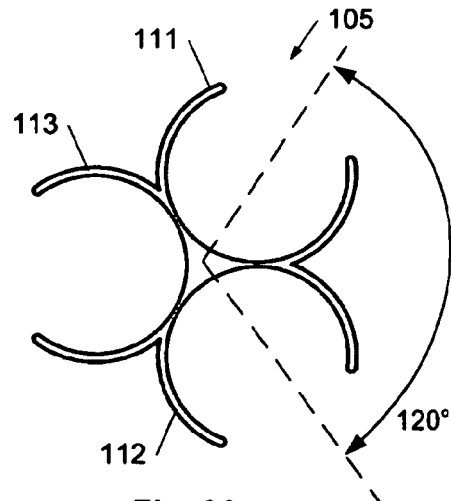

Fig. 26

TELESCOPIC COLUMN, PREFERABLY FOR FURNITURE

BACKGROUND OF THE INVENTION

Field of the Invention

The present invention relates to a telescopic column and to a telescopic cable guiding device and a telescopic lifting column prepared for mounting of a telescopic cable guiding device.

The Prior Art

Electrically-driven lifting columns constructed as table legs for height-adjustable tables have become well-known, just as electrically-driven lifting columns for hospital and care beds are well-known. Example of these types of lifting columns are found in WO/2004/040169 A1 and WO 2009/033486 A1, both Linak A/S. The electrically driven lifting columns are as a minimum in general connected to a power supply and an operation panel. On a desk there is typically also a computer with internet access, a desk lamp, telephone, etc., resulting in a welter of cables. This welter of cables is even more distinct in terms of hospital beds, where, besides the lifting columns, at least two linear actuators are connected for adjusting the slatted frame into a desired contour. Further, a control panel (ACP) for the staff is typically located at the foot of the bed, just as other equipment requiring a cabled connection may be connected to the bed.

Besides the fact that the welter of cables per se may cause accidents either as a result of the cables being incorrectly connected or the cables getting caught in something and thus ripping something off the table or bed or getting torn apart, the cables may also get squeezed in the structure and thus, at worst, be torn partially apart causing them to short-circuit.

WO 03/003876 Linak A/S discloses a three-part electrically driven telescopic lifting column for desks, where the lifting column is driven by an endless chain equipped with two rods, which are extended outwards in opposite directions. Here, a cable is received in a hollow in a bar-shaped element, around which the drive unit is constructed. This invention, however, only relates to guiding of one cable and is dedicated to the specific construction of the lifting column. WO 2007/112704 A1 Linet Spol. S.R.O. discloses an electrically driven telescopic lifting column for hospital beds, where an electric cable, based on fork-lift-like principle, is guided over a roll at the end of a vertical rod, in the intermediate member of a three-member lifting column.

The purpose of the invention is to provide a constructive simple solution for at least reducing the welter of cables.

SUMMARY OF THE INVENTION

This is achieved according to the invention by constructing the telescopic lifting column to include a telescopic cable guiding device for guiding at least one electric cable which collaborates in the movement of the telescopic lifting column. As such, it is possible to keep track of the cable guiding. Since the telescopic cable guiding device should not transfer forces, and since its members does not have to be extended synchronous, even in case of a synchronous lifting column, the telescopic cable guiding device may be manufactured from simple materials in a relatively simple manner and thus be inexpensive.

In one embodiment, the telescopic cable guiding device is constituted by telescopic rods, having the cable/cables secured thereto. In another embodiment the telescopic cable guiding device is constituted by a telescopic tube, with the cables being guided inside the tube. It is also possible to

place the cables on the outside of the tube or a combination thereof, i.e. both inside and outside the tube. When the cable is guided inside the telescopic tube, it gives the advantage that the cables are well-protected. The telescopic tube may be a simple plastic tube, but may also consist of thin rods assembled to form a tube-shape.

The telescopic cable guiding device may be placed outside the telescopic lifting column, which makes sense, when the telescopic cable guiding device is a telescopic tube. The location outside the telescopic column is particularly relevant when the cross section of said column is small or its hollow is filled with other equipment. It may of course also be a combination of a telescopic cable guiding device located both inside and outside the telescopic column. This is attractive in case of a large bundle of cables or cables running at a relatively long distance from each other.

Expediently, the telescopic cable guiding device will have as many telescopic members and be the same or almost the same length as the telescopic members of the lifting column. This gives advantages in the assembly process solely due to the fact that the number of telescopic members thus is as small as possible. It is however evident that the telescopic cable guiding device may have more members than the lifting column when appropriate.

Expediently, the telescopic cable guiding device terminates, at least with one end, in one end of the lifting column. This facilitates the assembly process of the telescopic cable guiding device.

In an embodiment, the telescopic cable guiding device comprises at least one electric cable running from one end of the telescopic cable guiding device to the other and at least in one end terminates in a plug. The telescopic cable guiding device may thus in advance be equipped with the desired cables. Extern cables may then simply be connected with a plug. In this connection it is noted that a plug may very well be a branch plug with more outlets.

In an embodiment, this or these plug/s are comprised by a plug module, which expediently may be mounted in extension of one end of the lifting column. The lifting column may also comprise a plug module in extension of each end of the lifting column. The plug module may further be adapted to comprise exactly the required type of plugs and the number of these.

The invention further relates to a telescopic cable guiding device for use in a lifting column, comprising at least two telescopically arranged profiles and means for securing the cable guiding device to the lifting column. The telescopic cable guiding device may expediently be constructed as a finished unit, which may comprise a desired number and type of cables and a desired number and type of plugs intended for mounting in or in connection with a lifting column.

The invention further relates to a telescopic lifting column prepared for mounting of a telescopic cable guiding device for guiding cables. The telescopic lifting column may thus be designed with a shaft-shaped hollow in its longitudinal direction terminating in an opening in a top plate and bottom plate, respectively. Thus, the telescopic cable guiding device may simply be inserted into the hollow and be secured to the top and bottom of the lifting column or in the vicinity thereof. The lifting column may be prepared for mounting of a telescopic cable guiding device by e.g. comprising mounting holes in the top and bottom plate. These holes may, if not used, be closed with a plug, which is pulled out when mounting the cable guiding device. For mounting of the telescopic device, the respective ends may comprise a collar which through a snap-lock connection may be secured in the

3

hole in the top and bottom plate of the lifting columns. Thus, the telescopic cable guiding device may in a simple and quick manner be mounted and dismounted without the risk of impacting or damaging the other parts of the lifting column.

The characteristics of the telescopic cable guiding device as a finished unit and the fact that it basically does not have to be part of the lifting column, makes it suitable for e.g. retrofitting in or in connection with the lifting column, which is prepared for this purpose. In case a need for an additional cable guiding or an increased number of cable guides should arise after commenced use of the lifting column, this is also possible. Likewise, a telescopic cable guiding device may be dismounted and remounted on or in connection with another lifting column. In line with this line of thinking, the plug module may likewise be retrofitted and configured to the needs at hand.

BRIEF DESCRIPTION OF THE DRAWINGS

The invention will be explained more fully below with reference to the accompanying drawings, in which

FIG. 1 shows a longitudinal section through a lifting column for beds, where the lifting column is shown in its fully extended position,

FIG. 2 shows a top plan view of the lifting column,

FIG. 3 shows a bottom plan view of the lifting column,

FIG. 4 shows a schematic view of a bed,

FIG. 5 shows a telescopic cable guiding device for guiding of cables, shown in a fully extended position,

FIG. 6 shows a telescopic cable guiding device in FIG. 5, shown in retracted position,

FIG. 7 shows a schematic view of a lifting column for a desk, as shown in FIG. 10, where the lifting column is shown in its fully extended position,

FIG. 8 shows a linear actuator for the lifting column, shown in FIG. 7,

FIG. 9 shows an exploded view of the housing with motor unit for the linear actuator, shown in FIG. 8,

FIG. 10 shows a schematic perspective of a height-adjustable desk, shown with a transparent table top,

FIG. 11 shows an alternative embodiment of the telescopic cable guiding device, shown internally from the telescopic lifting column,

FIG. 12 shows a detailed drawing of the upper end of the telescopic lifting column in FIG. 11,

FIG. 13 shows a detailed drawing of the lower end of the telescopic lifting column in FIG. 11,

FIG. 14 shows the telescopic lifting column in FIG. 1,

FIG. 15 shows the telescopic lifting column in FIG. 1, shown in perspective,

FIG. 16 shows the telescopic lifting column in FIG. 1 comprising a plug module, shown in perspective,

FIG. 17 shows the plug module in FIG. 16, shown in perspective from the front, where the profile piece has been removed,

FIG. 18 shows the plug module in FIG. 16, shown in perspective from the rear, where the profile piece has been removed,

FIG. 19 shows an embodiment of a telescopic cable guiding device comprising a cable, shown in perspective,

FIG. 20 shows the telescopic cable guiding device in FIG. 19 with a cut-away in the telescopically arranged profiles,

FIG. 21 shows the telescopic cable guiding unit in FIG. 19 comprising an alternative embodiment for ensuring the relative movement between the profiles,

4

FIG. 22 shows the telescopic cable guiding device in FIG. 19, shown from the end of the bottom,

FIG. 23 shows the telescopic cable guiding device in FIG. 21, shown from the end of the top,

FIG. 24 shows an embodiment of a telescopic cable guiding device comprising a cable, shown in perspective,

FIG. 25 shows a cross section of the outer profile of the telescopic cable guiding device, shown in FIG. 24,

FIG. 26 shows a cross section of the innermost profile of the telescopic cable guiding device, shown in FIG. 24, and

FIG. 27 shows a lifting column in retracted position having a shaft-shaped hollow and with the telescopic cable guiding device during mounting in the column.

DETAILED DESCRIPTION OF THE PREFERRED EMBODIMENTS

FIG. 1 shows a cross section of a three-part telescopic lifting column 1 for beds of the type disclosed in WO 2009/033486 A to Linak A/S which hereby constitutes part of the present application. The FIGS. 2 and 3 show the telescopic lifting column 1 shown from the top and bottom, respectively. As it appears from FIG. 1, the telescopic lifting column 1 consists of an outermost member 2, an intermediate member 3, and an innermost member 4. The telescopic lifting column 1 is driven by a chain unit 5, secured to the intermediate member 3. The chain unit 5 comprises an endless chain 6 running over two chain wheels (not referred to in the drawing). To each of the chain lengths between the chain wheels, a rod 7, 8 is secured to one end, whose other end is secured to the outermost member 2 and the innermost member 4, respectively. The chain unit 5 is driven by a drive unit comprising a spindle 9 driven by an electric motor 10 over a reduction gear (not shown). The drive unit is secured to the top of the innermost member 4. The spindle 9 is in mesh with a spindle nut (not shown) in the chain unit 5. By rotating the spindle 9 for extending the column, the chain unit 5 will be displaced, at which the chain is brought to move and the two rods 7, 8 will be displaced and thus will synchronously raise the intermediate member 3 out of the outermost member 2 while the innermost member 4 is extended out of the intermediate member 3. Depending on the direction of rotation of the spindle, the column will extend or retract, respectively.

FIG. 4 shows a schematic view of a hospital bed 11, comprising a lower frame 12 equipped with drive wheels 13 and an upper frame 14 with a supporting surface for the mattress. This supporting surface consists of a middle section 15 fixed in the upper frame 14, an adjustable back rest section 16 and an adjustable leg rest section 17. The two latter sections 16, 17 may be adjusted by means of linear actuators 18, 19. The upper frame 14 may as a whole be raised and lowered by means of a lifting column 20, 21 at each end. The bed may be operated with hand controls (not shown) and a control panel (ACP, Actuator Control Panel) located at the foot of the bed (not shown). As it appears, the lifting columns 20, 21 are secured to the lower frame 12 with the outermost member 2, so that both ends of the lifting columns 20, 21 are accessible.

For guiding the cables, the lifting columns are, as it appears from FIG. 1, equipped with a telescopic cable guiding device 22 designed as three telescopically arranged tubes 23, 24, 25. A longitudinal section in the telescopic cable guiding unit 22 is shown separately in FIGS. 5 and 6, in extended and retracted positions, respectively. The telescopic cable guiding device 22 consists, like the column, of three telescopically arranged tubes 23, 24, 25. The innermost

tube **23** of the telescopic cable guiding device **22** is, with its lower end, secured through the collar **26** to a bottom plate **27** in the outermost member **2**. The upper end of the outermost tube **25** is closed with a top plate **28** having a hole (not shown) through which the cable **29** may be guided. The top plate **28** is through an extension piece **30** secured to the top plate **31** mounted on the upper end of the innermost member **4** of the lifting column **1**. The telescopic cable guiding device **22** thus extends and retracts concurrently with the movement of the lifting column **1**. As stated above, the innermost and intermediate members **3**, **4** move synchronously. A synchronous movement of the members is not necessary for the telescopic cable guiding device **22**, as it is hidden. Ideally, the intermediate tube **24** is brought along by the outermost tube **25** in that the latter, at its lower end, has an internal dog (not shown), which is caught in an external dog (not shown) in the upper end of the intermediate tube **24**. Whether or not the friction between the two tubes **24**, **25** causes the intermediate tube **24** to be brought along from the beginning is of secondary importance. The dimensional tolerance between the individual tubes **23**, **24**, **25** is thus not critical, for which reason some play may unproblematically occur mutually between the individual tubes **23**, **24**, **25**. The fitting between the individual tubes **23**, **24**, **25** should thus not necessarily be constructed with, e.g., price-raising sliders. In its extended position, the intermediate tube **24** is stopped in that an external dog **40** is secured to a die-cut bottom plate **32** mounted in the lower end of the intermediate member **3**. The telescopic cable guiding device **22** terminates in a hole **33** in the bottom plate **27**. As it appears, a spiral cable **29** is located in the telescopic cable guiding device **22**. From the hole (not shown) in the top plate **28** of the outermost tube **25**, the spiral cable **29** is further guided to the top plate **31** of the lifting column, where it terminates in a plug **34**. At the bottom of the lifting column **1**, the spiral cable **29** is led through a sleeve **35** in the hole **33** in the bottom plate **27**. It is noted that the cable **29** here could also terminate in a plug. The cable **29** is thus well-protected in the tubular telescopic cable guiding device **22** without the risk of being squeezed in the lifting column **1**. The external cable guiding is thus also facilitated, as the cables may be connected to the lifting column **1** with plugs. Only one cable **29** is shown here, but more cables may be arranged in the telescopic cable guiding device **22**.

FIGS. 7-9 disclose an embodiment of a lifting column **36** for height-adjustable desks or sitting/standing tables, as they are known. FIG. 10 schematically discloses a desk **37** with a three-part telescopic lifting column **36** designed as a table leg at each side. The lower end of the telescopic lifting column **36** is secured in a foot **38**, while the top of the telescopic lifting column **36** is secured to a supporting surface (not shown) for a table top **39**, shown as transparent. The telescopic lifting column **36** may, e.g., be of the type disclosed in WO 2004/100632 A1 to Linak A/S where the telescopic movement is caused by a linear actuator, as shown in FIG. 8, comprising a spindle unit **41** driven by a motor unit **42** with a worm gear. A control box **43** containing a power supply and control unit for the telescopic lifting columns **36** is mounted under the table top **39**, while a control panel **44** is mounted at a front edge of the table top **39**. Inside the telescopic lifting column **36**, a telescopic cable guiding device **45** (see FIG. 8) for guiding electric cables is mounted together with the linear actuator. This telescopic cable guiding device **45** corresponds to the telescopic cable guiding device **22** described above and consists of three inside each other telescopically arranged plastic tubes **46**, **47**, **48**. The outermost tube **46** is located at the top where the

spindle unit **41** is thinnest and thus has more room. The outermost tube **46** is, with its upper end, secured to the bottom of the housing **49** of the actuator, in which a hole (not shown) is provided in connection with the tube. The cable or cables being guided through the telescopic cable guiding device **45** may terminate in a plug which is accessible through openings in the housing **49**, e.g., the cover **50** of the housing. The telescopic cable guiding device **45** is secured with the lower end of the innermost tube **48** to a bottom plate **51** in the outermost, thickest member **52** in the lifting column **36**. As the feet **38** of the table **37** are equipped with adjusting screws for adjusting to irregularities in the floor, the feet **38** are as such slightly raised from the floor, which thus provides room for guiding cables from, e.g., an outlet **53** in a floor to the telescopic cable guiding device **45**. The cable or cables being guided through the lifting column **36** may, e.g., be a mains cable for supplying, e.g., a monitor **54**, a desk lamp **55**, a control box **43** and a mobile phone **56**. It could also be a network cable, e.g., for connecting the computer **57** to the internet, and/or for central controlling of the desk lamp **55** and/or the control box **43**. In connection with cleaning, it could, e.g., be expedient to be able to raise the height-adjustable desk **37** and switch on the desk lamp **55**. It is noted that the cable or cables are guided discretely from an outlet **53** in the floor to the foot **38**, wherefrom the cable is connected to the cable guiding device **36** of the lifting column. If necessary, the lifting columns **36** of the height-adjustable table **37** could be equipped with a cable guiding device, by which one or more corresponding types of cables or other types of cables may be guided.

FIGS. 11-14 show selected elements from inside the telescopic lifting column **1** in FIG. 1, in an extended and retracted position, respectively, but where the telescopic cable guiding device **58** comprises an antenna-like guide, around which a spiral cable **29** is guided. The telescopic cable guiding device **58** thus comprises three telescopically arranged profiles **59**, **60**, **61**, which, e.g., could have a tubular cross-section. The innermost profile **59** can slide into the intermediate profile **60** and the intermediate profile **60** can slide into the outermost profile **61**. For reasons of clarity, the three members **2**, **3**, **4** (see FIG. 1) of the lifting column are not shown. Instead the top plate **31** is shown mounted on the upper end of the innermost member **4**, the bottom plate **62** is mounted on the lower end of the innermost member **4**, the bottom plate **32** is mounted on the lower end of the intermediate member **2**, and the bottom plate **27** is mounted on the lower end of the outermost member **2**. The outermost profile **61** is with its lower end secured to the bottom plate **27** (see FIG. 13) through the collar **64**. The spiral cable **29** is with the bracket **65** fixed to and thus guided along the bottom plate **27** and further through the outermost member **2** through a sleeve **66**. In an alternative embodiment, the spiral cable **29** could be led through the bottom plate **27** or be connected to a plug in the bottom plate **27** or in the bottom of the outermost member **2** (see FIG. 15). The upper end of the innermost profile **59** is secured to the top plate **31** through a bracket **67**. The spiral cable **29** is guided through a hole (not shown) in the bottom of the bracket **67**, past the electric motor **10** and further out through the top plate **31** through a sleeve **68**. The telescopic cable guiding device **58** is thus extended and retracted concurrently with the movement of the lifting column. As stated earlier, the innermost member **4** and intermediate member **3** of the lifting column move synchronous. A synchronous movement of the members **3**, **4** is not necessary as regards the telescopic cable guiding device **58** as it is hidden. Ideally, the intermediate profile **60** is brought along by the innermost profile **59** in that

the latter, at its upper end, has an external dog (not shown) which is caught against an internal dog (not shown) in the upper end of the intermediate profile **60**. Whether or not the friction between the two profiles **59, 60** causes the intermediate profile **60** to be brought along from the beginning is of secondary importance. In its extended position, the intermediate profile **60** is stopped by an external dog (not shown) in the lower end, which is caught by an internal dog (not shown) in the outermost profile **61**. FIG. **15** shows the telescopic lifting column **1** in perspective in a retracted position. The spiral cable **29** is here guided out of the bottom of the outermost member **2** and out of the top plate **31**. The telescopic lifting column **1** is here shown as connected to a supply cable **69** and corresponding power supply plug **70** in a power supply socket (not shown) of the type referred to as **71**, as shown in FIGS. **17** and **18**.

FIG. **16** shows the telescopic lifting column **1**, shown in perspective, comprising a plug module **72** mounted on the top plate **31** of the innermost member **4** and thus in extension of the lifting column **1**. In the shown embodiment, the plug module **72** comprises a profile piece **73** and a top plate **74** mounted in the upper end of the profile piece **73**. The plug module **72** is mounted in extension of the innermost member **4** of the lifting column **1** by means of screws **75, 76, 77, 78**. Here, the plug module **72** comprises two plugs, a power supply socket (not shown, see reference number **71** in FIGS. **17** and **18**) for the telescopic lifting column **1**, and a mains socket (not shown, see reference number **79** in FIGS. **17** and **18**). The telescopic lifting column **1** further comprises a mains socket (not shown) in the bottom of the outermost member **2**. For illustrative reasons, the sockets in FIG. **16** are here equipped with a corresponding plug and cable piece (not referred to in the drawing).

In FIGS. **17** and **18**, the profile piece **73** on the plug module **72** is in all essentials removed such that the rear side of the mains socket **79** and the power supply socket **71** is visible. As shown in FIGS. **11-14**, the cable **29** protrudes through the top plate **31**. This cable **29**, which by means of the telescopic cable guiding device **22, 45, 58** is guided through the telescopic lifting column **1**, should be connected to the mains socket **79**. For reasons of clarity, this is not shown in the figure. The power supply socket **71** has been moved from its location in the top plate **31**, as shown in FIG. **15**, to a location in the profile piece **73** next to the mains socket **79**. The cable connecting the power supply socket **71** is not shown. The plug module **72** is intended as an optional addition to the telescopic lifting column **1**. The plug module may have more or less plugs depending on the specific needs of the user.

FIGS. **15-19** show another embodiment of a telescopic cable guiding device **80**, comprising three telescopically arranged profiles **81, 82, 83** for guiding the cable **84**. It is noted that the cable **84** in this embodiment is not a spiral cable. The profiles **81** and **82** have a U-shaped cross section and comprise a C-shaped guide **89, 90, 91, 92** intended for mesh with the intermediate profile **83** at the end of each long side **85, 86, 87, 88**. The intermediate profile **83** is constituted by two independent flat pieces **93, 94** and comprises a boss **95, 96, 97, 98** at the ends of the cross section, which may mesh with the C-shaped guide **89, 90, 91, 92** on the profiles **81, 82**. The two profiles **81, 82** and the intermediate profile **83** form a hollow (not referred to in the drawing), in which part of the cable **84** may be arranged. This can be done such that the cable **84** is led into the hollow at the bottom of the profile **81** and out at the top of the profile **82**. In the formed hollow, the cable **84** will with advantage could run in a S-shape or Z-shape (see FIG. **16**). In this way, a cable length

approximately corresponding to the full length of the three profiles **81, 82, 83** may be accumulated. The telescopic cable guiding device **80** is thus suitable to guide one or more cables inside a lifting column. The telescopic cable guiding device **80** could e.g. be incorporated in a lifting column **1** of type, shown in FIGS. **1** and **15**.

Such incorporation may be achieved in that the lower end of the profile **81** is secured to an element in fixed connection with the bottom of the lifting column or e.g. by direct securing to the bottom plate **27** in the outermost member **2** (see FIGS. **1** and **3**). The upper end of the profile **82** is by means of e.g. a bracket secured to the top of the innermost member **4** of the lifting column. The intermediate profile **83** is further secured to the lower end of the intermediate member **3** by means of e.g. a snap-lock connection through the hole **99**, directly in or via the bracket in the intermediate profile **83**. Thus, the telescopic cable guiding device **80** extends and retracts concurrently with the movement of the lifting column. As stated earlier, the innermost **3** and intermediate member **4** of the lifting column move synchronous. The securing of the telescopic cable guiding device **80** in the lifting column likewise causes the two profiles **81, 82** to move synchronous. The combination of this synchronous movement and the securing of the intermediate profile **83** to the intermediate member **3** results in that the three profiles **81, 82, 83** does not fall out of their mutual mesh.

In an alternative embodiment of the telescopic cable guiding device **80**, as shown in FIG. **17**, only the profiles **81, 82** are secured to the bottom and top, respectively of the lifting column as described earlier. The intermediate profile **83** is, however, not secured to the intermediate member **3**, but comprises two dogs **100, 101** instead at each end of the intermediate profile **83**. The U-shaped clamp **102** is secured to the outer side of the profile **82**. The long sides of the clamp **102** extend over the intermediate profile **83**, so that the clamp **102** may mesh with one of the two dogs **100, 101**, depending on whether the profile **82** moves in the upwards or downwards direction. The intermediate profile **83** may thus be guided in the same direction as the profile **82**. In addition to contributing to that the intermediate profile **83** moves in the desired direction, this alternative embodiment of the telescopic cable guiding device further ensures that the individual profiles **81, 82, 83** does not fall out of mesh with each other via the C-shaped guides **89, 90, 91, 92** and the bosses **95, 96, 97, 98**.

FIG. **24** shows another embodiment of a telescopic cable guiding device **103**, comprising two telescopically arranged profiles, an outermost profile **104** and an innermost profile **105**. FIGS. **25** and **26** show a cross section of the outermost profile **104** and the innermost profile **105**, respectively. Both profiles **104, 105** are oblong, but are, for reasons of clarity, shown shortened with a cut, so that only the respective ends and a small portion of the profiles **104, 105** are visible. The outermost profile **104** has a circular exterior **106** and further comprises three tubular guides **107, 108, 109**. An arc-piece on each of the three tubular guides **107, 108, 109** is secured to the inner side of the circular exterior **106**, such that the longitudinal axis of the three tubular guides **107, 108, 109** and the circular exterior **106** are parallel. The three lines, running from the center axis of the circular exterior **106** to the intersection with the center axis of each of the tubular guides **107, 108, 109**, is symmetrical to a mutual angle of approximately 120° (degrees). The external sides of the three tubular guides **107, 108, 109** do not touch each other, but together with the circular exterior **106** instead forms an opening **110** in which the innermost profile **105** may be inserted. The innermost profile **105** comprises three

9

C-shaped pieces **111**, **112**, **113** joined back to back, so that the horizontal centre lines through each of the C-shaped guides **111**, **112**, **113** are placed with a mutual angle of approximately 120° (degrees). The innermost profile **105** may thus be extended into the opening **110** in the outermost profile **104**. Together, the three tubular guides **107**, **108**, **109** and the three C-shaped guides **111**, **112**, **113** form a telescopically displaceable cable guide, preferably for a spiral cable **29**. The telescopic cable guiding device **103** may, like the other embodiments of the telescopic cable guiding device **22**, **45**, **58**, be secured inside a telescopic lifting column.

The invention claimed is:

1. A telescopic lifting column comprising:
 - at least two mutually telescopic members,
 - an electric drive unit for moving the at least two telescopic members relative to one another and extending or retracting the telescopic lifting column,
 - at least one electric cable, and
 - a telescopic cable guiding tube within which said at least one electric cable is guided, said telescopic cable guiding device tube being positioned inside said at least two telescopic members and extending between and connected to lower and upper ends of the lifting column to extend or retract with extension or retraction of the lifting column.
2. The telescopic lifting column according to claim 1, wherein the telescopic tube guides at least two electric cables.
3. The telescopic lifting column according to claim 1, wherein at least a first electric cable is guided in a hollow of the telescopic tube, and at least a second electric cable is guided on an outside of the telescopic tube.
4. The telescopic lifting column according to claim 1, wherein the telescopic cable guiding device comprises at least the same number of members as the telescopic lifting column.

10

5. The telescopic lifting column according to claim 1, wherein at least one end of the telescopic cable guiding device terminates in one end of the telescopic lifting column.

6. The telescopic lifting column according to claim 1, wherein the at least one electric cable, which extends between the lower and upper ends of the telescopic cable guiding device, and at least in one end terminates in a plug.

7. The telescopic lifting column according to claim 6, wherein the plug is a branch plug with more outlets.

8. The telescopic lifting column according to claim 6, wherein at least a first electric cable terminates in at least a first plug, and at least a second electric cable terminates in at least a second plug.

9. The telescopic lifting column according to claim 1, including at least one plug module with at least one plug.

10. The telescopic lifting column according to claim 9, wherein at least one plug module is mounted in continuation of the telescopic lifting column.

11. The telescopic lifting column according to claim 10, wherein at least one plug module is mounted in continuation of a top of the telescopic lifting column.

12. The telescopic lifting column according to claim 10, wherein at least one plug module is mounted in continuation of a bottom of the telescopic lifting column.

13. The telescopic lifting column according to claim 10, wherein at least one plug module is mounted and integrated in one of the members of the telescopic lifting column.

14. The telescopic lifting column according to claim 1, including means for securing the telescopic cable guiding tube in the lifting column.

15. The telescopic lifting column according to claim 1, wherein the lifting column in its longitudinal direction is constructed with a shaft shaped hollow terminating in an opening in a top plate and a bottom plate, respectively.

16. The telescopic lifting column according to claim 1, wherein the electric drive unit is located at an upper end of the telescopic lifting column.

* * * * *