

(12) UK Patent Application

(19) GB

(11) 2 247 857 (13) A

(43) Date of A publication 18.03.1992

(21) Application No 9016887.3

(22) Date of filing 01.08.1990

(71) Applicant
Trigon Packaging Systems (UK) Limited

(Incorporated in the United Kingdom)

**Stafford Park 9, Telford, Shropshire, TF3 3BZ,
United Kingdom**

(72) Inventors
**Robert Christopher Smith
Lloyd Phillip Omundsen**

(74) Agent and/or Address for Service
**R J Gordon & Company
17 Richmond Hill, Richmond Upon Thames,
Surrey, TW10 6RE, United Kingdom**

(51) INT CL⁵
B29C 53/36

(52) UK CL (Edition K)
B5K K1

(56) Documents cited
None

(58) Field of search
UK CL (Edition K) **B5K K1 K3A4 K3A5 K3A5A
K3A5B K3B
INT CL⁵ B29C**

(54) **Plastics film with permanent fold**

(57) In a method of providing plastics film material (10) with a permanent fold the material (10) is drawn between a roller having a circumferential groove of "V" shape cross section and a cooperating disc whereby cooperation of the groove and the disc creates formation of a rectilinear crease (14) in the material, the crease (14) extending downwardly from an upper surface (15) of the material (10). The upper surface (15) then has applied thereto a coating of adhesive (16) which bridges the crease (14) and the adhesive (16) is covered by a cover strip (17) having a coating of silicone such that the strip (17) is peelable from the adhesive (16). The effect of the adhesive (16) is such that, on passing from the co-operating roller and disc, the crease 14 is maintained in the material (10) by means of the adhesive (16).

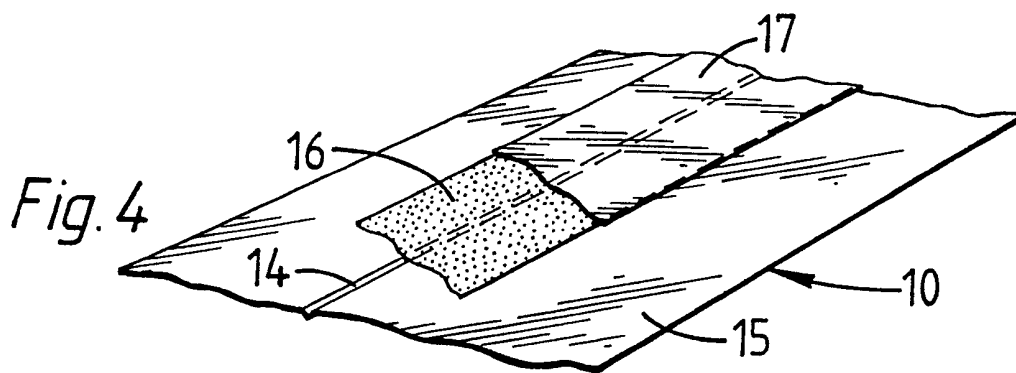

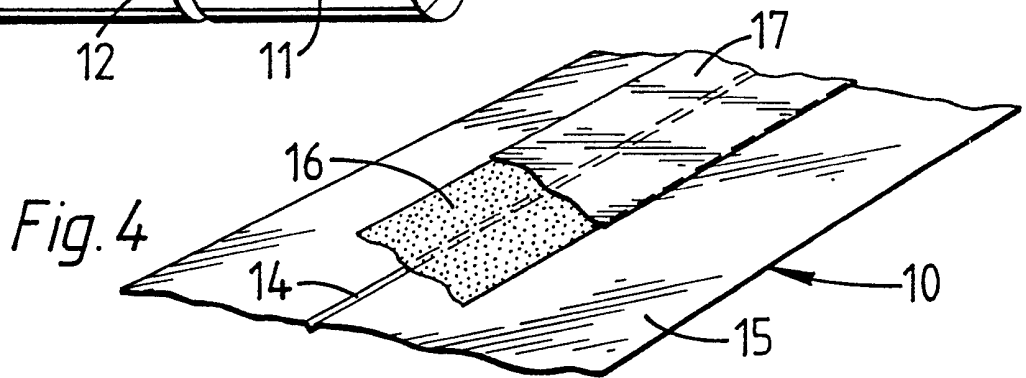
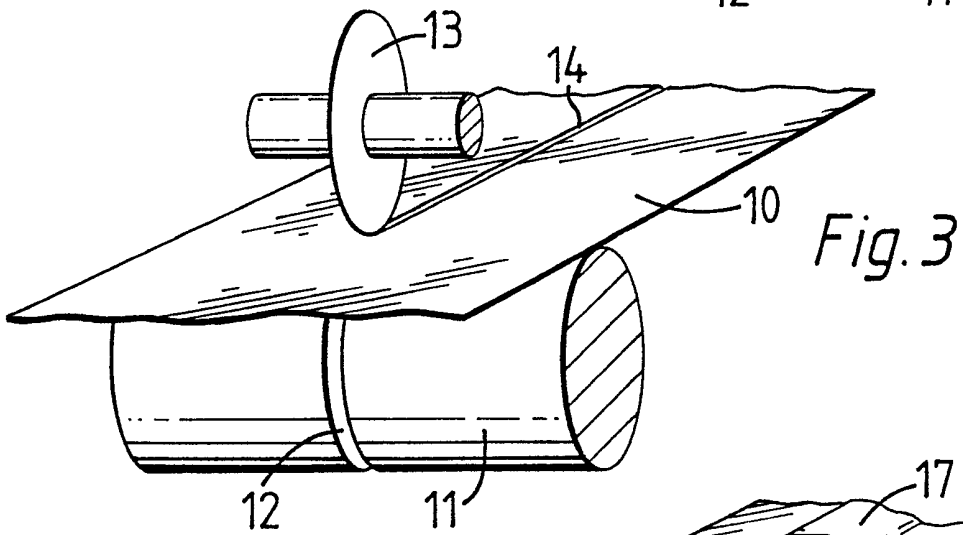
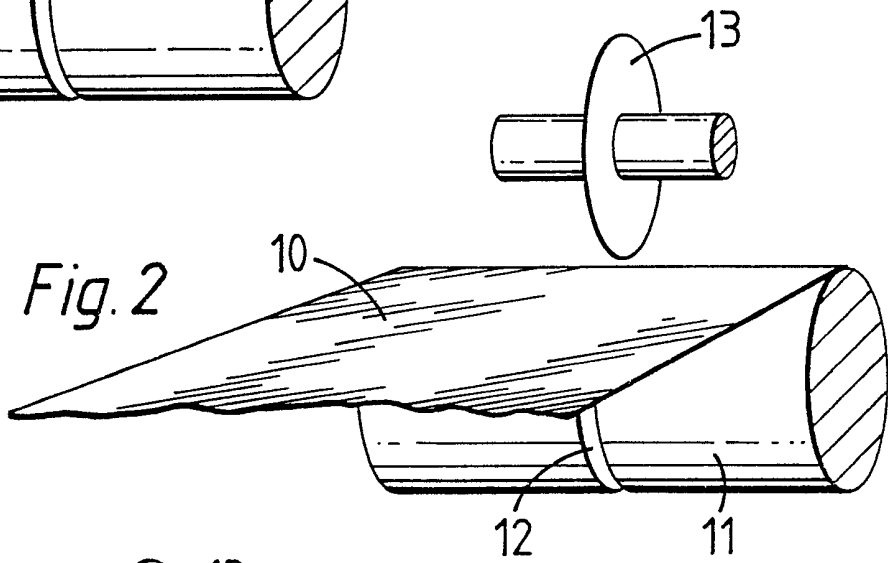
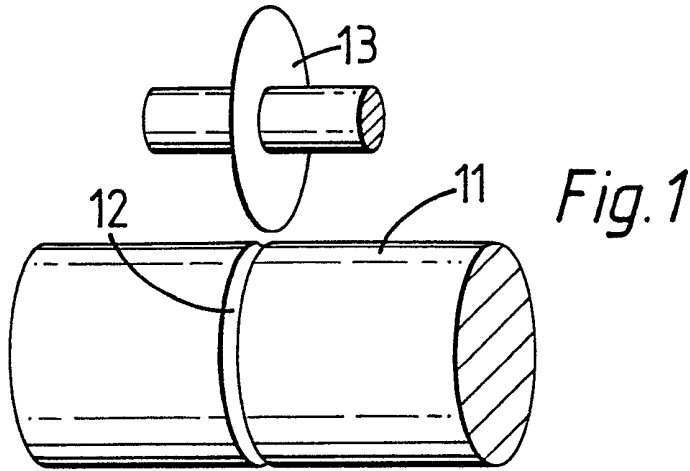

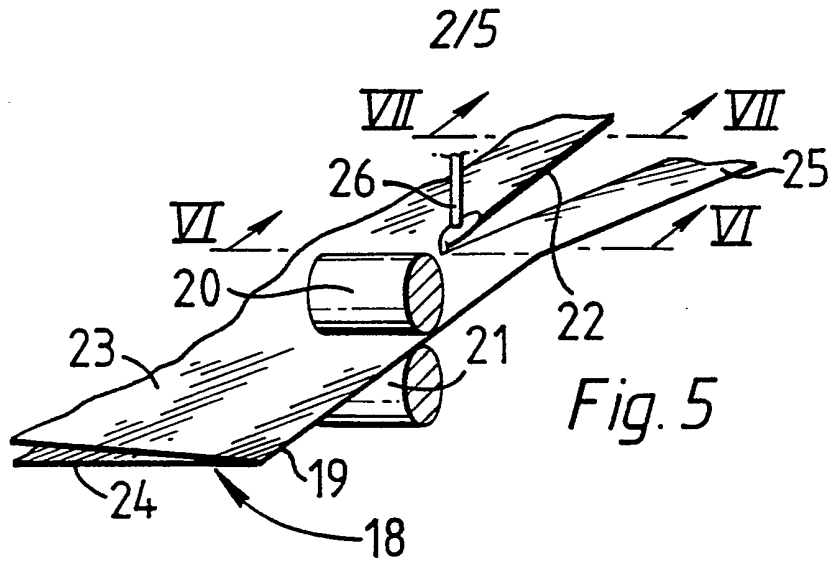

Fig. 5

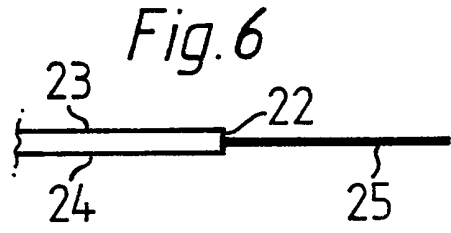

Fig. 6

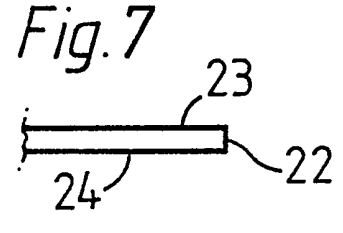

Fig. 7

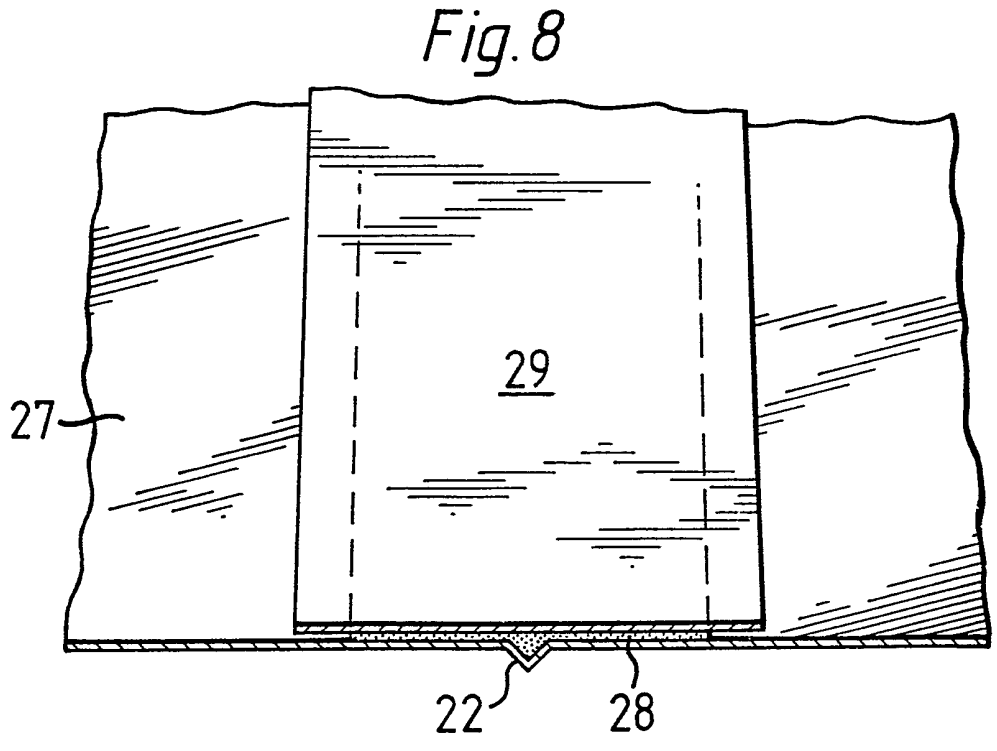

Fig. 8

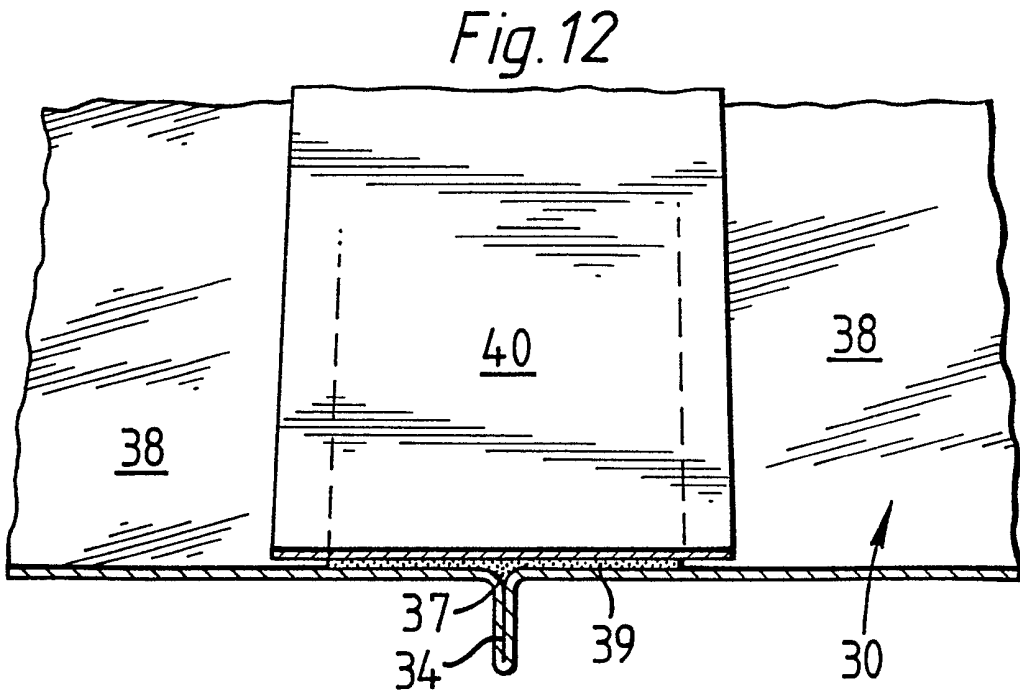
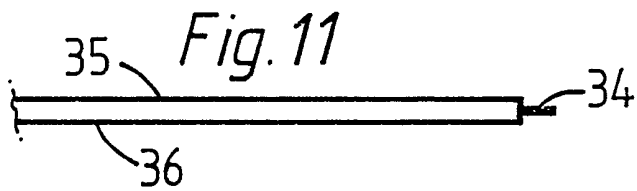
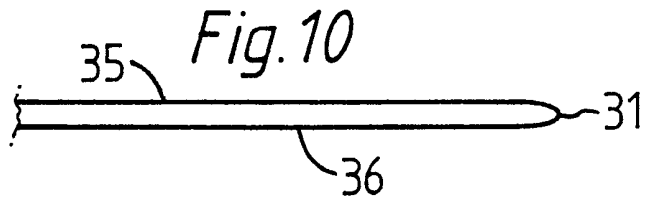
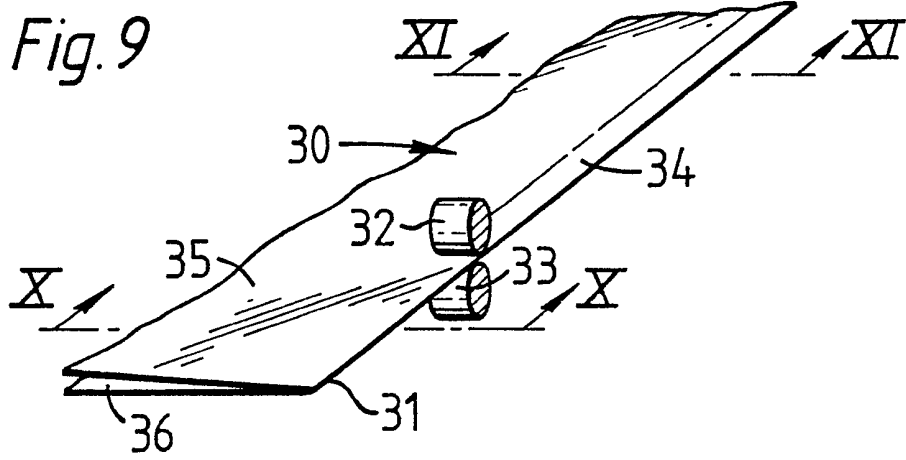

Fig. 13

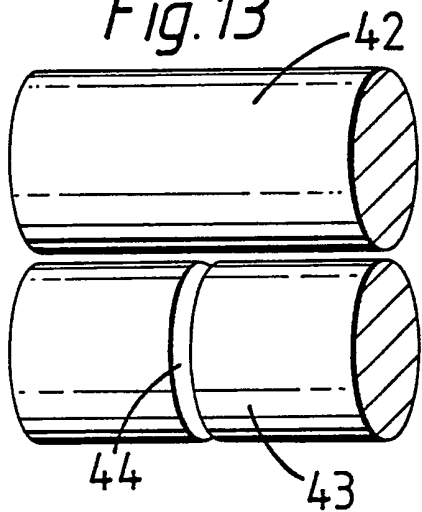

Fig. 14

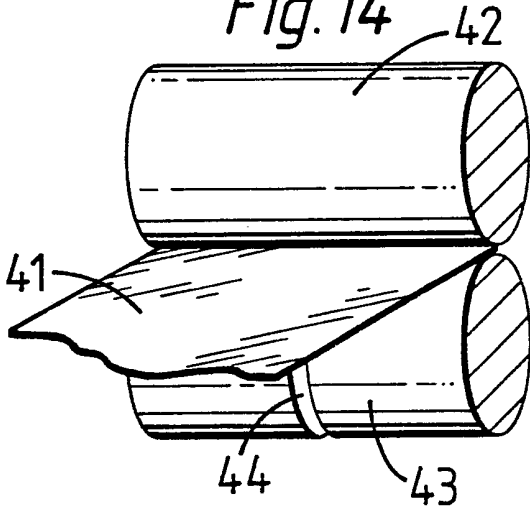

Fig. 15

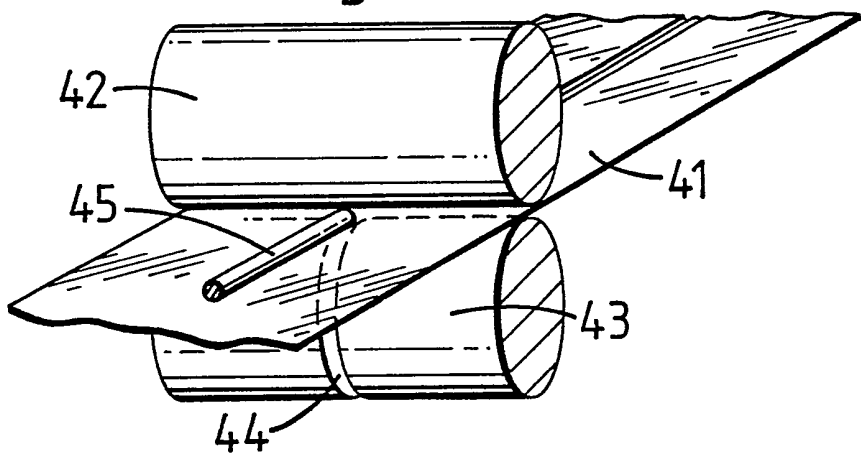

Fig. 16

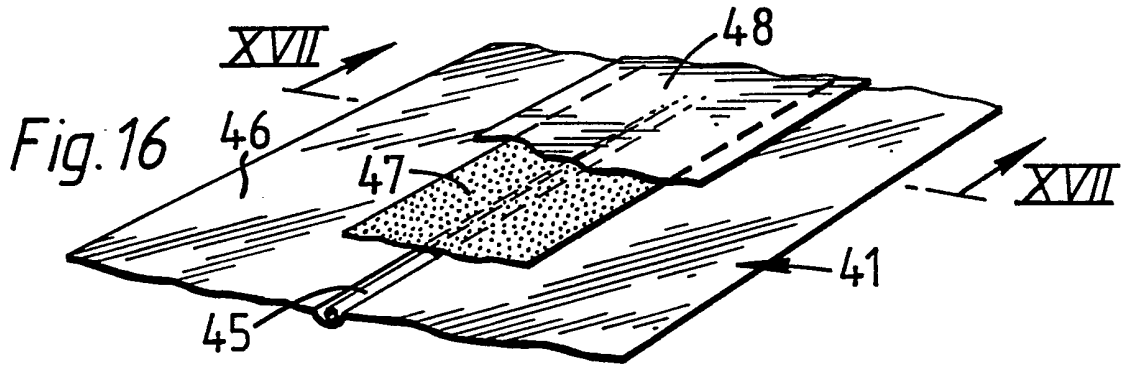
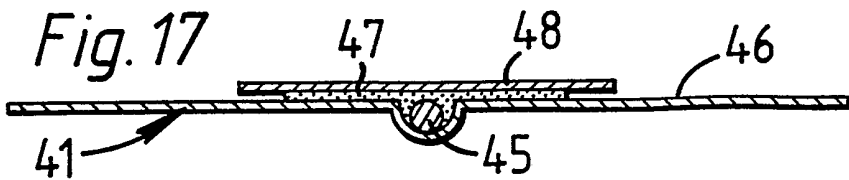
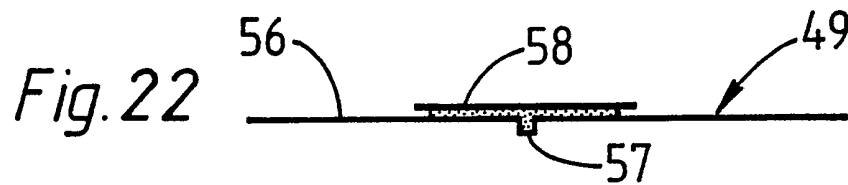
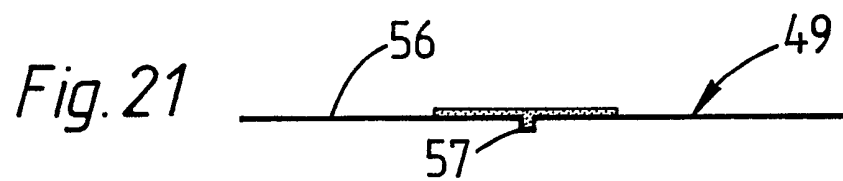
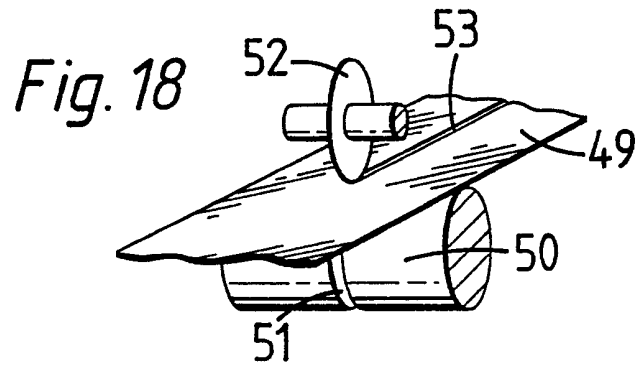

Fig. 17





Plastics Film with Permanent Fold

This invention relates to a method of providing plastics film material with a permanent fold and to a container including a component of plastics film material having a permanent fold provided by the method.

It is known to provide containers of plastics film material with a flap carrying pressure sensitive adhesive wherein a container is closed by folding a flap over a mouth of the container and securing the flap to an opposite facing surface by means of the adhesive. An example of such a container is disclosed in European Patent Application No 90302862.9.

A disadvantage of such closures is that considerable dexterity is required to ensure that a flap is folded neatly and in a correct position. This is of considerable importance with a security envelope since it is important that a flap of the envelope be folded precisely and secured wrinkle free since otherwise evidence of tampering is difficult to determine.

It is desirable, therefore, to provide a closure flap of such a container with a permanent fold by means of which the flap will be folded at a predetermined location and ensure that, when the container is being closed, the flap is perfectly aligned with a corresponding predetermined surface with which it is intended to unite in effecting closure of the container.

According to the present invention, a method of providing plastics film material with a permanent fold comprises the steps of subjecting the material to controlled pressure such as to form the material to a configuration including an elongate recess, applying to a surface of the film an adhesive such as to maintain the configuration and removing the pressure, the configuration thereby providing a permanent fold in the material.

Following is a description, by way of example only and with reference to the accompanying drawings, of one method of carrying the invention into effect.

In the drawings:-

Figures 1 to 4 inclusive are diagrammatic representations of one embodiment of the method in accordance with the present invention,

Figures 5 to 8 inclusive are diagrammatic representations of another embodiment of the method in accordance with the present invention,

Figures 9 to 12 inclusive are diagrammatic representations of another embodiment of the method in accordance with the present invention,

Figures 13 to 17 are diagrammatic representations of another embodiment of the method in accordance with the present invention and

Figures 18 to 22 are diagrammatic representations of another embodiment of the method in accordance with the present invention.

Referring now to Figures 1 to 4 of the drawings, there is shown a "Creasing" method of providing plastics film material with a permanent fold. According to the method, plastics film material 10 is drawn between a roller 11 having a circumferential groove 12 of "V" shape cross section and a co-operating disc 13 whereby co-operation of the groove 12 and disc 13 creates formation of a rectilinear crease 14 in the film 10 the crease extending downwardly from an upper surface 15 of the film 10. The upper surface 15 then has applied thereto a coating of adhesive 16 which bridges the crease 14 and the adhesive is covered by a cover strip 17 having a coating of silicone on a surface thereof adjacent the adhesive 16 such that the cover strip 17 is peelable from the adhesive 16. The effect of the adhesive coating 16 is such that, on passing from the co-operating roller 11 and disc 13, the groove 12 is maintained in the film 10 by means of the adhesive 16.

It will be appreciated that the permanent crease 14 provides a so-called "dead" fold in the plastics film material 10 such

that the material 10 is hinged longitudinally of the crease 14. If, therefore the film 10 is used as a closure flap for a container, the flap is provided with a hinge defined by the crease 14 at a predetermined location such that the flap, when folded to close a container, is positioned accurately with regard to a surface with which it engages in order to effect closure of the container.

Referring now to Figures 5 to 8 of the drawings, there is shown a "Slit/Seal" method wherein plastics film material 18 is folded as shown at 19 and overlapping portions of the material 18 extending from the fold 19 are passed through the nip of a pair of co-operating heated pressure rollers 20,21 thereby forming a crease 22 uniting a layer 23 of the film 18 overlapping a layer 24 of the film and forming an elongate web 25 of the material 18 extending from the crease 22. The web 25 is severed from the crease by a heated cut/seal tool as shown at 26 and the overlapping portion 23 of the film 18 is turned away from the underlying portion 24 as shown in Figure 8. An upper surface 27 of the film 18 has applied thereto an adhesive 28 which bridges the crease 22. The adhesive 28 is covered by a cover strip 29 having a coating of silicone on a surface thereof adjacent the adhesive 28.

Referring now to Figures 9 to 12 of the drawings, there is shown a "Folded/Heat Seal" method which is similar to the method shown in Figures 5 to 8 in that plastics film material 30 is folded as shown at 31, and a portion of the folded

material is passed through heated pressure rollers 32,33 thereby providing a web 34 whereby opposite facing portions of the folded film are sealed one to another. However, unlike the method shown in Figures 5 to 8, the web 34 is not severed. The presence of the web 34 united with the layer 35 and the underlying layer 36 of the film 30 provides a permanent crease 37 at the junction of the layers 35, 36 about which the layers 35,36 are foldable relative one to another. The superimposed layer 35 is pivoted relative to the crease 37 such that an upper surface 38 of the film 30 can have applied thereto an adhesive 39 bridging the crease 37. The adhesive is covered by a cover strip 40 having a silicone coating on the surface thereof adjacent the adhesive 39.

Referring now to Figures 13 to 17 of the drawings, there is shown a "Beaded" method wherein a film 41 is inserted through the nip of a pair of co-operating pressure rollers 42,43, one of which is provided with a circumferential groove 44 of substantially semicircular configuration, and an elongate polyethylene thread 45 of substantially circular cross-section is laid on an upper surface 46 of the film 41 such as to cooperate with the groove 44 as the film 41 passes through the nip of the rollers 42, 43. On passing from the nip the rollers 42,43 the upper surface 46 of the film 41 has applied thereto adhesive 47 which bridges the groove 44 and the adhesive is covered by a cover strip 48 having on a surface thereof adjacent the adhesive 47 a coating of silicone.

Referring now to Figures 18 to 22 of the drawings, there is shown an "Adhesive Creasing" method which is similar to the method shown in Figures 1 to 4 in that a film 49 is fed between a co-operating roller 50 having a groove 51 and a disc 52 whereby the co-operation of the disc 52 and the groove 51 creates a crease 53 in the film 49.

Unlike in the method shown in Figures 1 to 4, however, the "Adhesive Creasing" method shown in Figures 18 to 22 provides for application of two strips of adhesive 54, 55 to an upper surface 56 of the film 49 on either side of the crease 53. The downwardly extending crease then is pinched by pinch rollers (not shown) the effect of which is to draw the material forming the crease 53 downwardly such that opposite facing margins of the portions of adhesive 54,55 are united one with another to form a depending elongate rib 57. The united portions of adhesive 54,55 then have applied thereto a cover strip 58 having a coating of silicone on a surface thereof adjacent the adhesive 54,55.

Claims

1. A method of providing plastics film material with a permanent fold comprising the steps of subjecting the material to controlled pressure such as to form the material to a configuration including an elongate recess, applying to a surface of the film an adhesive such as to maintain the configuration and removing the pressure, the configuration thereby establishing a permanent fold in the material.

2. A method as claimed in Claim 1 wherein subsequent to the adhesive having been applied to the film a release cover strip is applied to the adhesive.

3. A method as claimed in Claim 1 or Claim 2 wherein formation of the configuration is effected by including an elongate member in the recess.

4. A method as claimed in Claim 1 or Claim 2 wherein a portion of the material extending from the recess is removed subsequent to the formation of the configuration.

5. A container including a component of plastics film material having a permanent fold provided by a method as claimed in any one of the preceding Claims.