

(19) World Intellectual Property Organization
International Bureau



(43) International Publication Date
5 August 2010 (05.08.2010)

PCT

(10) International Publication Number
WO 2010/088640 A2

(51) International Patent Classification:
E01C 23/06 (2006.01) *B60K 26/00* (2006.01)
E01C 19/40 (2006.01)

(21) International Application Number:
PCT/US2010/022800

(22) International Filing Date:
2 February 2010 (02.02.2010)

(25) Filing Language: English

(26) Publication Language: English

(30) Priority Data:
61/149,092 2 February 2009 (02.02.2009) US
61/157,401 4 March 2009 (04.03.2009) US

(71) Applicant (for all designated States except US):
SOMERO ENTERPRISES, INC. [US/US]; 16831 Link Court, Fort Myers, Florida 33912 (US).

(72) Inventors; and

(75) Inventors/Applicants (for US only): **HALONEN, Philip D.** [US/US]; 54871 Golf Course Road, Calumet, Michigan 49913 (US). **KANGAS, Matthew A.** [US/US]; 15896 Obenhoff Road, Atlantic Mine, Michigan 49931 (US). **KIERANEN, Carl B.** [US/US]; 44851 Paradise Road, Chassell, Michigan 49916 (US). **ANDERSON, Frank E.** [US/US]; 50234 Rauhala Road, Atlantic Mine, Michigan 49905 (US).

(74) Agents: **VAN DYKE, GARDNER, LINN & BURKHART, LLP** et al.; 2851 Charlevoix Drive SE, Suite 207, Grand Rapids, Michigan 49546 (US).

(81) Designated States (unless otherwise indicated, for every kind of national protection available): AE, AG, AL, AM, AO, AT, AU, AZ, BA, BB, BG, BH, BR, BW, BY, BZ, CA, CH, CL, CN, CO, CR, CU, CZ, DE, DK, DM, DO, DZ, EC, EE, EG, ES, FI, GB, GD, GE, GH, GM, GT, HN, HR, HU, ID, IL, IN, IS, JP, KE, KG, KM, KN, KP, KR, KZ, LA, LC, LK, LR, LS, LT, LU, LY, MA, MD, ME, MG, MK, MN, MW, MX, MY, MZ, NA, NG, NI, NO, NZ, OM, PE, PG, PH, PL, PT, RO, RS, RU, SC, SD, SE, SG, SK, SL, SM, ST, SV, SY, TH, TJ, TM, TN, TR, TT, TZ, UA, UG, US, UZ, VC, VN, ZA, ZM, ZW.

(84) Designated States (unless otherwise indicated, for every kind of regional protection available): ARIPO (BW, GH, GM, KE, LS, MW, MZ, NA, SD, SL, SZ, TZ, UG, ZM, ZW), Eurasian (AM, AZ, BY, KG, KZ, MD, RU, TJ, TM), European (AT, BE, BG, CH, CY, CZ, DE, DK, EE, ES, FI, FR, GB, GR, HR, HU, IE, IS, IT, LT, LU, LV, MC, MK, MT, NL, NO, PL, PT, RO, SE, SI, SK, SM, TR), OAPI (BF, BJ, CF, CG, CI, CM, GA, GN, GQ, GW, ML, MR, NE, SN, TD, TG).

Declarations under Rule 4.17:

- as to applicant's entitlement to apply for and be granted a patent (Rule 4.17(ii))
- as to the applicant's entitlement to claim the priority of the earlier application (Rule 4.17(iii))
- of inventorship (Rule 4.17(iv))

[Continued on next page]

(54) Title: APPARATUS AND METHOD FOR IMPROVING THE CONTROL OF A CONCRETE SCREEDING MACHINE

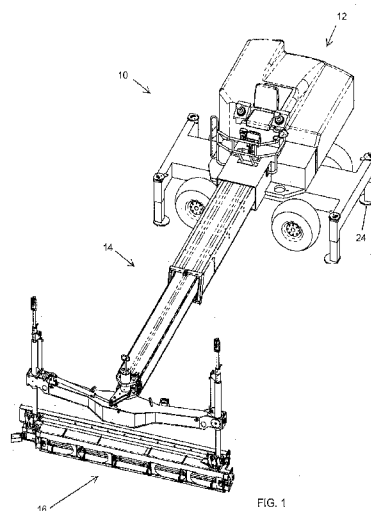

(57) Abstract: A screeding machine comprising at least one of (a) a boom speed cruise control for automatically controlling the travel speed of the screed head assembly, (b) an auto-stabilizer control that automatically adjusts the stabilizer actuators of the screeding machine to a preselected degree of extension, (c) a control for automatically controlling the lowering of the screed head assembly toward and to the concrete surface and automatically activating the auger and vibrator at a beginning of each screeding pass and automatically deactivating the auger and vibrator in response to the screed head assembly being raised away from the concrete surface at the end of a screed pass, and (d) an auto-screed mode that allows the operator to select maximum values for at least one of a boom extension speed, a boom retraction speed, a boom rotation speed and a screed head rotation speed.



WO 2010/088640 A2

Published:

- *without international search report and to be republished upon receipt of that report (Rule 48.2(g))*

APPARATUS AND METHOD FOR IMPROVING THE CONTROL
OF A CONCRETE SCREEDING MACHINE
FIELD OF THE INVENTION

[0001] The present invention relates generally to an apparatus and method for improving the control and productivity of a concrete screeding machine during the leveling and smoothing of freshly poured concrete that has been placed over a surface.

BACKGROUND OF THE INVENTION

[0002] There is a continuous and growing need within industry for flat and level close-tolerance concrete floors used in a variety of structures such as office buildings, shopping centers, warehouses, and production and/or manufacturing facilities. Most modern production and manufacturing plants include high-precision machinery and equipment which must be set level on a flat surface. A main benefit from achieving close-tolerance floors is that it will allow for easier installation and set-up of the precision machinery and equipment. This allows a facility to reach its intended level of performance capacity sooner and at a higher level of quality. Facility maintenance costs are also likely to be reduced. When changes to the machinery become necessary, reorganization and set-up of the equipment can also be less costly.

SUMMARY OF THE INVENTION

[0003] The present invention provides a screeding machine that comprises at least one of (a) a boom speed cruise control for automatically controlling the travel speed of the screed head assembly, (b) an auto-stabilizer control that automatically adjusts the stabilizer actuators of the screeding machine to a preselected degree of extension, (c) a control for automatically controlling the lowering of the screed head assembly toward and to the concrete surface and automatically activating the auger and vibrator at a beginning of each screeding pass and automatically deactivating the auger and vibrator in response to the screed head assembly being raised away from the concrete surface at the end of a screed pass, and (d) an auto-screed mode that allows the operator to select maximum values for at least one of a boom extension speed, a boom retraction speed, a boom rotation speed and a screed head rotation speed.

[0004] Optionally, the screeding machine may include a joy-stick steering system that is operable to control the steering of at least two of the wheels, with the joy-stick steering system providing an operator steering control of the wheels by means of a joy-stick control handle,

and whereby the steering of the wheels of the screeding machine may be controlled electronically by operator positional input at the joy-stick control handle. Optionally, the screeding machine may include a right joystick control and a left joystick control for controlling respective functions of the screeding machine, wherein the right joystick control at least initially controls first functions and the left joystick control controls second functions. Optionally, the screeding machine may include a joystick swap control that is actuatable by an operator of the screeding machine, whereby the right joystick control controls the second functions and the left joystick control controls the first functions in response to actuation of the joystick swap control.

[0005] Optionally, the screeding head assembly may have an auger and a vibrating member for screeding the concrete surface, and may further comprise auger bearings for rotatably supporting the auger. The screeding head assembly may include an adjustment mechanism that allows an operator of the screeding machine to change the auger bearings and the auger without having to adjust a height adjustment of the auger after reassembly of the auger bearings and the auger, whereby the auger height adjustment settings are maintained without any readjustment. Optionally, the screeding head assembly may include a pair of detachable transport stands for supporting opposite ends of the screed head assembly at a support surface when the screeding machine is being transported.

[0006] These and other objects, advantages, purposes and features of the present invention will become apparent upon review of the following specification in conjunction with the drawings.

BRIEF DESCRIPTION OF THE DRAWINGS

[0007] FIG. 1 is a perspective view of a concrete leveling and screeding machine that incorporates the improved operator controls and control systems and screed head apparatus design improvements and features of the present invention;

[0008] FIG. 2 is a perspective view of the screed head and telescopic boom assembly of the concrete leveling and screeding machine shown in FIG. 1;

[0009] FIG. 3 is a perspective view of the lower portion of an optional 12.5 foot screed head assembly of the present invention;

[0010] FIG. 4 is an enlarged perspective view of the area A of the left end of the screed head assembly of FIG. 3, showing components of an auger adjustment mechanism of the present invention;

[0011] FIG. 5 is a perspective view of an optional 14.5 foot screed head assembly of the present invention, shown in a partial state of disassembly;

- [0012] FIG. 6 is an enlarged perspective view of the area A of the auger adjustment mechanism of FIG. 5, shown in a partial state of disassembly, where the auger and auger bearing subassembly has been removed from the auger support beam structure of the screed head assembly;
- [0013] FIG. 7 is a detailed view including instructional steps for removal and reinstallation of the improved auger adjustment mechanism of the present invention, where the auger and auger bearing subassembly has been removed from the auger support beam structure of the screed head assembly (note that this adjustment mechanism design allows the operator to change the auger bearings and auger as desired without having to readjust the height adjustment of the auger after reassembly, or, in other words, the auger height adjustments settings can therefore be readily maintained without any necessary readjustment so long as the height adjustment bolt and locknut are not loosened);
- [0014] FIG. 8 is a perspective view of the auger bearing subassembly of the present invention;
- [0015] FIG. 9 is a perspective exploded view of the auger bearing subassembly of FIG. 8;
- [0016] FIG. 10 is a perspective view of the stop plate welded assembly of the improved auger adjustment mechanism;
- [0017] FIG. 11 is a perspective view of the underside of a 14.5 foot auger support beam welded assembly structural member of a screed head assembly of the present invention;
- [0018] FIG. 12 is an enlarged perspective view of the left end area A of the underside of the 14.5 foot auger support beam welded assembly structural member of FIG. 11;
- [0019] FIG. 13 is a perspective view of the screed elevation beam structural support assembly of a screed head assembly of the present invention, showing the screed head hydraulic manifold access door closed;
- [0020] FIG. 14 is an enlarged perspective view of the area A of the center portion of the screed elevation beam structural support assembly of the screed head assembly of FIG. 13, showing the screed head hydraulic manifold access door closed;
- [0021] FIG. 15 is a perspective view of the screed elevation beam structural support assembly of a screed head assembly of the present invention, showing the screed head hydraulic manifold access door open;
- [0022] FIG. 16 is an enlarged perspective view of the area A of the center portion of the screed elevation beam structural support assembly of FIG. 15, showing the screed head hydraulic manifold access door open (with pivot stop pin shown);
- [0023] FIG. 17 is a perspective view of the screed elevation beam structural support assembly of the screed head assembly, showing the screed head hydraulic manifold in a pivoted-out

position for improved access (note that the manifold may be pinned or retained in the pivoted-out position via a retaining pin or the like being inserted into a hole or aperture in the beam and engaging the manifold to limit pivotal movement of the manifold);

[0024] FIG. 18 is an enlarged perspective view of the area A of the center portion of the screed elevation beam structural support assembly of the screed head assembly of FIG. 17, showing the screed head hydraulic manifold in a pivoted-out position for improved access (with the pivot stop pin shown above a hole in the manifold plate that may be aligned with a second corresponding hole or notch or portion of the screed elevation beam structural support assembly to limit pivotal movement of the manifold);

[0025] FIG. 19 is a perspective view of the 12.5 foot screed head and telescopic boom assembly of the concrete leveling and screeding machine shown in FIG. 1, where the screed head assembly is tipped and the plow is pinned in the raised position for improved access for ease of cleaning and maintenance;

[0026] FIG. 20 is an enlarged perspective view of the left end area A of the 12.5 foot screed head assembly of FIG. 19, where the screed head assembly is tipped and the plow is pinned in the raised position for improved access for ease of cleaning and maintenance;

[0027] FIG. 21 is a left side elevation view of the 12.5 foot screed head and telescopic boom assembly of the concrete leveling and screeding machine shown in FIGS. 19 and 20, where the screed head assembly is tipped for improved access for ease of cleaning and maintenance;

[0028] FIG. 22 is an enlarged side elevation of the left end area A of the 12.5 foot screed head assembly of FIG. 21, where the screed head assembly is tipped for improved access for ease of cleaning and maintenance;

[0029] FIG. 23 is a rear perspective view of the 12.5 foot screed head and telescopic boom assembly of the concrete leveling and screeding machine shown in FIG. 1, where the screed head assembly is tipped and the plow is pinned in a raised position for improved access for ease of cleaning and maintenance;

[0030] FIG. 24 is an enlarged perspective view of the left end area A of the 12.5 foot screed head assembly of FIG. 23, where the screed head assembly is tipped and the plow is pinned in the raised position for improved access for ease of cleaning and maintenance;

[0031] FIG. 25 is a left side perspective view of the 12.5 foot screed head and telescopic boom assembly of the concrete leveling and screeding machine shown in FIG. 1, where the screed head assembly is tipped and the plow is pinned in the raised position for improved access for ease of cleaning and maintenance;

[0032] FIG. 26 is an enlarged perspective view of the left end area A of the 12.5 foot screed head assembly of FIG. 25, where the screed head assembly is tipped and the plow is pinned in the raised position for improved access for ease of cleaning and maintenance;

[0033] FIG. 27 is a perspective view of the lower portion of the 12.5 foot screed head assembly of the concrete leveling and screeding machine shown in FIG. 1, where the plow assembly, pivoting yoke welded assembly, pivot bushings, hardware, and self-leveling hydraulic cylinder are shown in exploded view (note that the self-leveling cylinder mounting bolts have been omitted for clarity);

[0034] FIG. 28 is an enlarged perspective view of the area A of the lower portion of the 12.5 foot screed head assembly of FIG. 27, where the plow assembly, pivoting yoke welded assembly, pivot bushings, hardware, and self-leveling hydraulic cylinder are shown in exploded view (note that the self-leveling cylinder mounting bolts have been omitted for clarity);

[0035] FIG. 29 is a perspective view of the lower portion of an optional 14.5 foot screed head assembly, including a detachable transport stand for supporting the screed head assembly on a surface when the machine is being transported;

[0036] FIG. 30 is an enlarged perspective view of the left end area A of the lower portion of the optional 14.5 foot screed head assembly of FIG. 29, showing a detachable transport stand for supporting the screed head assembly on a surface when the machine is being transported (note that the two attachment hex bolts and hex nuts or optionally two securable steel hitch pins are not shown in FIG. 30; and there are two detachable transport stands, one secured at each end of the screed head for transport, and this feature limits or prevents damage to the screed head vibrator, auger, and plow during shipment in containers or transport of the machine on over highway trailers);

[0037] FIG. 31 is a perspective view of a detachable transport stand welded assembly for supporting the screed head assembly during shipment or transport;

[0038] FIGS. 32A-C are schematics that depict various degrees of extension of a large boom and small boom of the screeding machine of the present invention, with a propel switch and a boom cushion switch for controlling extension and retraction of the booms in accordance with the present invention;

[0039] FIGS. 33A-E are perspective views of an operator station and left and right control panels and right and left joy sticks suitable for use with a screeding machine in accordance with the present invention; and

[0040] FIGS. 34-38 depict aspects of the control systems and control logic diagrams of a screeding machine and/or system in accordance with the present invention.

DESCRIPTION OF THE PREFERRED EMBODIMENTS

[0041] For the purposes of illustration and disclosure of the aspects of the present invention, a Somero SXP-D LASER SCREED™ screeding machine will be used as the example. However, clearly this example is not intended to limit the scope of the present application and clearly aspects of the present invention are suitable for use on other types of screeding machines.

[0042] A typical wide-placement concrete pour might consist of a set of eight to sixteen screeding passes from left to right before another row is started. This number of consecutive passes can typically complete the full-width of a typical wide-placement concrete pour. During each screeding pass made by a LASER SCREED™ screeding machine (or other suitable screeding machine or device) and its respective human operator, a number of human factor variables can come into play that can often affect the level of quality achieved in the final concrete surface. For instance, the travel speed of the screed head as it travels over the surface of the concrete during the concrete leveling and screeding process can vary from one pass to the next, and can even vary even within the scope of a single screeding pass. The travel speed of the screed head is a function of the telescopic boom retraction speed which is controlled by the operator, typically by hand, through an electro-hydraulic hand-lever or joystick controller. Because of the infinitely variable nature of the joy-stick controller within its given range of movement and speed adjustment capability, the operator can often find it difficult or nearly impossible to accurately make repeatable screeding passes of exactly the same speed once he has identified a particular ideal travel speed for retracting the boom and the screed head given the prevailing site conditions and specific characteristics of the concrete. The experience and skill level of the operator can often become a significant and deciding factor in the final outcome or the resulting quality of the concrete surface. Screeding machine operators who are less experienced, skilled, or knowledgeable may not be able to provide the required level of repeatability and consistency with respect to the ideal travel speed of the boom and screed head. Additionally, because of the human-factor, operator fatigue begins to emerge as a factor that can affect the consistency of travel speed of the screed head and therefore quality as screeding operations extend over a long number of hours or late into the night. Therefore, there is an identified need in the concrete screeding industry for a screeding machine (such as a Somero LASER SCREED™) with a control system that can readily provide operators with a repeatable and consistent screed control functions such as, but not

limited to screed head travel speed (i.e. boom retraction speed) while screeding concrete surfaces. This particular aspect of screeding machine control, for example, may be referred to as a "Boom Speed Cruise Control" control apparatus and method suitable for use with screeding machines, such as Somero LASER SCREED™ screeding machines or other suitable screeding machines.

[0043] Similarly, and for many of the same reasons previously stated in the preceding paragraphs, additional control-based apparatus, improvements, and methods are described herein (see below discussion and accompanying overview and diagrams and Figures) and provided to help reduce the human-factor variable of the operator and operator fatigue while concurrently improving the control and productivity of screeding machines. The newly developed control apparatuses, methods, and related design features of the present invention are described below.

[0044] Referring now to the drawings and the illustrative embodiments depicted therein, a screeding machine 10 includes a wheeled unit 12 with a boom 14 extending therefrom and supporting a screeding head or assembly 16 at an outer end thereof (FIG. 1). The wheeled unit 12 is drivable to a targeted area at a support surface with uncured concrete placed thereat, and the wheeled unit may rotate about a base portion to swing the boom and screeding head to a targeted location. The boom 14 is extendable and retractable to move the screeding head 16 over the placed concrete, while the screeding head 16 is operable to establish a desired grade of the concrete surface and smooth or finish or screed the concrete. In the illustrated embodiment, the screeding head includes a plow 18, a grade setting device or auger 20 and a vibrating member 22 (FIG. 3). The screeding machine includes a plurality of stabilizers 24 that are extendable and retractable to support and stabilize the machine on the support surface during the screeding operation. Screeding machine 10 and the screeding head or assembly 16 may be similar in construction and/or operation as the screeding machines and screeding heads described in U.S. Pat. Nos. 4,655,633; 4,930,935; 6,227,761; 7,044,681; 7,175,363; and/or 7,396,186, which are hereby incorporated herein by reference in their entireties, such that a detailed discussion of the overall construction and operation of the screeding machines and screeding heads need not be repeated herein. The various improvements or aspects of the present invention are discussed below under the appropriate headings and sub-headings.

Screeding Machine Screed Head Improvements

[0045] In addition to the control-based apparatus, improvements, and methods of the present invention (such as discussed in detail below), a number of design and functional improvements to the screed head assembly of a screeding machine, such as a Somero LASER SCREED™

machine, are provided by the present invention. These unique screeding machine design aspects and improvements are intended to improve performance and reliability by making adjustment, service and maintenance, and cleaning of the screed head throughout the life of the machine a much easier task for the machine operator. These design and functional improvements are discussed below.

Shim-Less Auger Adjustment

[0046] A typical screeding machine screed head includes the ability to adjust the auger position vertically with respect to the vibrating member and strike-off plow. The outer edges of the auger flighting tend to gradually wear away as the auger is continuously engaged with and moving the abrasive aggregate-filled concrete material. Depending upon the specific nature of the concrete and the rates of wear of the flighting, it is not uncommon for a screeding machine operator to have to adjust the height or elevation of the auger with respect to the vibrating member and the strike-off plow on a periodic basis.

[0047] Typical screeding machines, such as LASER SCREED™ machines, have traditionally relied upon various thicknesses of specially made aluminum shim plates that are sandwiched between the pillow-block auger bearings which provide support and allow rotation of the auger relative to the support structure or what is generally known as the auger support beam of the screed head assembly. Various numbers and thicknesses of shims are added or subtracted at each of the two auger bearings to achieve the desired height of the auger with respect to the strike-off plow and vibrating member of the screed head assembly. The loosening and tightening of the two threaded hex nuts, which are threaded onto their respective steel threaded rods or studs, which are then threaded into the auger support beam, has often proven to be difficult for the operator, since the exposed threads of the components are typically coated with at least some of hardened concrete. In severe cases, the hardened concrete can become substantially thick including small amounts of aggregate and sand. Such an environment is by no means desirable for threaded fasteners requiring periodic loosening and tightening, having threads that are exposed and sometimes directly engaged with the concrete being screeded. The hardened concrete can also tend to adhere to the exposed surfaces of the aluminum shim plates and other components further increasing adjustment difficulties for the operator.

[0048] A screed head assembly in accordance with the present invention may include an improved auger adjustment mechanism that eliminates the need for various thickness shims and the necessity to turn concrete-coated hex nuts and threaded fasteners which are inherently in direct contact with the uncured concrete during screeding operations. As shown in FIGS. 3-9, an auger bearing subassembly 26 provides rotational support for each end of the auger 20

and by design allows the height or elevation to be readily adjusted with respect to the auger support beam structure or welded assembly 28 and the entire screed head assembly 16. FIG. 3 illustrates the lower portion of a 12.5 ft screed head assembly, while FIG. 4 is a detailed view of the left end of the lower portion of the screed head assembly in its assembled and functional state. The left end of the lower portion of the screed head assembly also includes the hydraulic drive motor 30 which drives the auger 20 rotationally while concrete is being screeded. The direction of rotation according to this view (FIG. 4) is counterclockwise, while the direction of travel of the complete screed head assembly is generally from left to right. FIG. 5 shows the lower portion of a comparable 14.5 foot screed head assembly, while FIG. 6 is an exploded view illustrating removal of the auger and auger bearing subassembly from the auger support beam 28.

[0049] The auger motor 30 would also typically be detached from the auger in this instance for facilitate disassembly of the auger and auger bearing subassembly. The auger bearing subassembly 26 includes a bearing 26a that receives a shaft end 20b of the auger 20 (with the auger flighting 20a being disposed between the shaft ends of the auger) therein and that is supported at a lower portion of a bracket 26b that is secured or fastened (such as via fasteners 32) to an end portion 28a of the auger support beam welded assembly 28. A stop plate welded assembly or bracket 34 functions to support the auger bearing subassembly 26 and the auger 20 when the fasteners 32 are loosened. With the two larger fasteners 32 located within the two vertical slots 28b of the auger support beam welded assembly 28 loosened or removed, the auger 20 and auger bearing subassembly 26 are entirely supported against the force of gravity by stop plate welded assembly 34. As can be seen with reference to FIGS. 4 and 6, stop plate welded assembly 34 fits into and engages both a square opening 28c at the end 28a of the auger support beam welded assembly 28 and a square opening 26c of the bracket 26b of auger bearing subassembly 26.

[0050] FIG. 10 illustrates the stop plate welded assembly 34, which includes a dowel pin 34a at the rear for engagement with a correspondingly-sized hole 28d (FIG. 12) within the inner bearing support plate 28e of the end portion 28a of auger support beam welded assembly 28 and a fastener clearance hole 34b centrally located in the front tab 34c of the stop plate welded assembly 34. When in the assembled position, the stop plate welded assembly 34 is secured within the square opening 28c of the auger support beam welded assembly 28 and the square opening 26c of the auger bearing subassembly 26 by a fastener 35 (such as a small hex head cap screw and flat washer or the like) that threads into the outer bearing support plate 28f of auger support beam welded assembly 28. Thus, when in the assembled position, the stop plate

welded assembly 34 provides a horizontal support member between the inner and outer bearing support plates 28e, 28f of the auger support beam weldment 28.

[0051] When assembled, the head of the fully-threaded auger height adjustment bolt 26d rests upon the upper surface 34d of the stop plate welded assembly 34. Turning or adjustment of this adjustment bolt causes the bearing subassembly 26 to be moved upward or downward depending in the direction in which it is turned. The adjustment bolt 26a is threadedly engaged to the central hole 26e at the top plate 26f of the auger bearing sub assembly 26. A locknut 26g is provided to secure the adjustment bolt with respect to the top plate once any adjustments have been completed. Adjustment is complete when the two larger fasteners 32 are again tightened while engaged through the two vertical slots 28b of the auger support beam welded assembly 28 and corresponding internally threaded holes within the U-shaped solid aluminum block or bracket 26b of the auger bearing subassembly 26. As can be seen in FIGS. 11 and 12, the bracket 26b of auger bearing subassembly 26 is received between the inner and outer plates 28e, 28f of end portion 28a of auger support beam welded assembly 28. When so positioned, the stop plate welded assembly 34 may be inserted through the square holes 28c, 26c to support the auger bearing subassembly 26 at the auger support beam welded assembly 28.

[0052] Optionally, a tapered aluminum transition plate 26h may be provided between the U-shaped aluminum block 26b and the auger bearing 26a to eliminate the step that would otherwise exist at the top surface outer edges of the auger bearing 26a. These small surfaces would otherwise tend to collect to excess concrete and require extra effort in while cleaning the machine at the end of the day. A small metal cover 28g may be provided to conceal and otherwise protect the auger height adjustment bolt 26d and its threads from any excess concrete that could splash into the square opening 28c of the adjustment mechanism. In the illustrated embodiment, two fasteners or bolts 26i may serve to secure the subassembly 26 together while the respective threads of the fasteners 26i remain protected from exposure to concrete as they are engaged into the internally threaded holes within the housing of auger bearing 26a.

[0053] As a further advantage related to the adjustable auger height mechanism and design, it is also practical to provide the machine operator with a set of optional replacement parts such that the auger adjustment assembly 26 and related mechanism can offer a preferred or selected amount or degree of adjustment for each complete full turn of the threaded auger height adjustment bolt 26d. For example, an initial production machine may include a threaded auger height adjustment bolt 26d that includes a 1/2 inch diameter thread with 13 threads per inch (1/2-13 UNC (Unified Coarse Thread)). The corresponding locknut 26g and top plate 26f include the same internal thread size for engagement of the bolt. In such an embodiment, one

full turn of the auger height adjustment screw 26d corresponds to approximately .077 inches of advancement of the adjustment bolt and a corresponding change of height of the auger relative to the screed head assembly.

[0054] Optionally, alternate adjustment bolt thread sizes can be provide to the machine operator along with correspondingly threaded sets of locknuts 26g and top plates 26f, such that a different or preferred or selected amount or degree of adjustment can be achieved by a complete full turn of the threaded height adjustment bolt or screw 26d. For example, various sets of replacement parts (such as other UNC components or UNF (Unified Fine Thread) components or metric components) may include the following standard thread sizes:

$\frac{1}{2}$ -13 UNC thread = about 0.077 inches per turn;

$\frac{1}{2}$ -20 UNF thread = about 0.050 inches per turn;

12 mm x 1.75 thread = about 1.75 mm per turn (about 0.069 inches per turn);

14 mm x 2.00 thread = about 2.00 mm per turn (about 0.079 inches per turn).

In each application, the machine operator may equip the screeding machine such that each turn of the auger adjustment bolt or screw 26d can represent a preferred or selected or appropriate amount of auger height adjustment, thereby making such adjustments easier for the operator to track and/or monitor.

Screeding Head Manifold Access

[0055] The screed head assembly 16 of screeding machine 10 is supported by a screed elevation beam structural support assembly 36, which is, in the illustrated embodiment, a generally horizontally oriented beam structure that is pivotally mounted at the outer end of the boom assembly 14 and pivotable about a generally vertical axis, such as via extension and retraction of an actuator 38a (FIG. 2). The screed head assembly 16 may be vertically adjusted relative to the screed head elevation beam 36 via a pair of elevation actuators 38b, such as in a known manner. As can be seen with reference to FIGS. 13-18, the screed elevation beam 36 may comprise a hollow center portion 36a for encasing a hydraulic manifold 40 therein, and with a manifold access door 36b that is openable to access the manifold 40 and closable to conceal or seal the manifold within the beam 36.

[0056] As shown in FIGS. 15 and 16, the manifold access door 36b may be opened by pivoting the door about a generally horizontal hinge axis at its lower edge, whereby the manifold 40 is viewable through the opening in the center portion 36a of the beam 36. In the illustrated embodiment, the manifold 40 is mounted to a mounting plate 40a, which is pivotally mounted to the beam 36. Thus, when the door 36b is opened, the manifold 40 may be swung or pivoted

outward from the beam cavity so as to protrude outward through the door opening for easy access to the manifold.

[0057] In the illustrated embodiment, the manifold 40 and mounting plate 40a are lockable or securable in either the stowed position (FIG. 16) or the access position (FIG. 18) via a pivot stop pin or retaining pin 42. The manifold and/or mounting plate thus may be pinned or retained in the pivoted-out position or pivoted-in position via retaining pin 42 being inserted into a hole or aperture 40b in the mounting plate 40a and engaging or at least partially inserting into a hole or aperture 36c in the beam to limit pivotal movement of the manifold at the desired position. For example, and as shown in FIG. 18, the screed head hydraulic manifold may be moved or pivoted or swung to the pivoted-out position for improved access, and the pivot stop pin (shown above the hole 40b in the manifold plate 40a in FIG. 18) may be aligned with a hole or notch or portion of the screed elevation beam structural support assembly to limit pivotal movement of the manifold in the pivoted-out or access position.

Tip-To-Clean Screed Head

[0058] A typical and desired or necessary aspect of LASER SCREED™ machine operation is periodic pressure washing of the machine and in particular washing and cleaning of the components of the screed head assembly that have been exposed to concrete. An on-board pressure washer powered by the machine's engine and hydraulic system is typically available as a standard equipment option on Somero LASER SCREED™ screeding machines; however, other stand-alone industrial pressure washing equipment can also be used. Water for pressure washing is provided by any number of sources on available on a construction site. Typically, pressure washing occurs at the end of the particular screeding job, or at the end of the day after the machine is no longer expected to be used in uncured concrete. On some occasions, such as where very large and lengthy concrete screeding jobs are underway, an operator may elect to wash the machine periodically throughout the job to help limit or avoid or prevent concrete from setting-up and hardening onto the exposed surfaces of the machine. This practice helps to limit or avoid the possibility of concrete hardening and curing on the machine before a very lengthy job is complete, where otherwise proper cleaning of the machine is likely to become increasingly difficult over time with the passage of several hours.

[0059] To make pressure washing, cleaning, and even service and maintenance of the screed head assembly easier for the machine operator, the present invention may provide a "Tip-To-Clean" design feature for screeding machines, such as Somero LASER SCREED™ screeding machines. This design aspect provides the operator with the ability to both raise and further tip the screed head assembly to a relatively extreme angle in such a way that access to the screed

head and its components is greatly improved, especially with regard to pressure washing and cleaning.

[0060] Typical Somero LASER SCREED™ screeding machines have been known to have utilized a patented screed head self-leveling system, whereby the angle-of-attack of the screed head is actively controlled and maintained within a specific range of levelness by an electronically-controlled level sensor, controller, a pair of hydraulic self-leveling cylinders and an hydraulic system. Such a screed head self-leveling system is described in U.S. Pat. No. 4,930,935, entitled SCREEDING APPARATUS AND METHOD, which is hereby incorporated herein by reference in its entirety, such that the details of this system need not be presented herein.

[0061] With reference to FIGS. 19-26, a screeding machine 10 with a screed head 16 and telescopic boom assembly 14 is illustrated with the screed head in the "Tip-To-Clean" position. The relatively extreme angle of the "Tip-To-Clean" position has been developed and made possible by the specific stroke of the self-leveling actuators or hydraulic cylinders 44, the specific geometry of the mechanical elements, freedom of movement, pivot point locations, and the mechanical clearances thus provided. A specially designed clearance pocket or depression or cutaway 45 at the upper portion of the auger support beam is provided at or near each end of the screed head. These clearance pockets or depressions are designed to allow greater rotation of the screed head assembly such that the screed head support yokes 47 will be provided with the necessary clearance to rotate to a relatively extreme angle with respect to their axis of rotation without contact or interference with the top portion of the auger support beam. In the illustrated embodiment, the extreme angle capability is approximately 30 degrees in the plow up direction of screed head rotation, which is well beyond the typical range of motion of approximately 10 degrees in either direction, which is typical for adjusting and correcting the angle-of-attack of the screed head assembly during screeding operations.

[0062] The extreme "tip-to-clean" angle position of the screed head assembly is achieved by the machine operator whereby the automatic self-leveling control system is de-activated and placed in a manual mode of operation. With the control system in manual mode of operation, the operator then manually activates the self-level control system to further adjust and rotate the screed head to its maximum plow-up position of rotation. This further manual activation by the operator is typically well beyond the normal range of automatic control for the self-leveling control system.

[0063] In addition to the extreme angle capability of the screed head in the plow-up direction of rotation, the strike-off plow assembly 18 can be further lifted by the operator through

physical effort and pinned into a further raised position by use of a spare bolt or pin 46a (such as, for example, a steel pin of approximately $\frac{3}{4}$ inch in diameter), which is mechanically inserted into a boss 46b (FIGS. 24, 26 and 28), which includes a corresponding thru-hole, and which is welded to the structure of the auger support beam. The spare bolt or pin thus provides an effective stop by which the strike-off plow is held in the further raised position. This combination of design features provides a significant and useful improvement toward greatly improved access to the screed head assembly for the purposes of service, maintenance, inspection, and especially with regard to pressure washing and cleaning.

[0064] For normal screeding operations, the screed head is readily returned to its normal position by simply removing the spare bolt or pin, lowering the plow and manually actuating the self-leveling control system in order to return it to standard position within its normal range of automatic angle-of-attack control. Upon return of the assembly to its normal operation position, no additional adjustments to the screed head assembly are expected or necessary.

Detachable Transport Stands

[0065] Optionally, and as shown in FIGS. 29-31, a detachable transport stand 48 may be provided for supporting the screed head assembly 16 on a surface when the machine is being transported. Although only one detachable transport stand is shown in FIGS. 29-31, there are two transports stands, one secured at each end of the screed head for transport. This feature limits or prevents damage to the screed head vibrator, auger, and plow during shipment of the machine in containers or transport of the machine on over highway trailers or the like.

[0066] In the illustrated embodiment, the detachable transport stand 48 comprises a generally U-shaped bracket with a generally planar base portion 48a and upwardly extending arms 48b. The ends of the arms 48b provide spaced apart arms that receive the inner and outer plates 28e, 28f of end portion 28a of auger support beam welded assembly 28, while the U-shaped lower portion of the stand provides clearance for the auger motor 30 and auger bearing subassemblies 26 when the stands support the screed head assembly on a support surface. The upper ends of the arms 48b have holes 48c therethrough for receiving pins or fasteners (such as two attachment hex bolts and hex nuts or optionally two securable steel hitch pins or the like) therethrough for securing or fastening the stand to the plates 28e, 28f to secure the screed head assembly to the support stand 48. The holes 48c are typically through-holes but may optionally be threaded to allow threaded fastening and securing of the fasteners to the plates 28e, 28f and the support stand 48.

[0067] Optionally, the detachable support stands may be further fastened or secured to the floor of the container or transport, such as via one or more fasteners inserting or threading at

least partially through the base portion 48a and the floor of the container or transport. Thus, when the screed head and/or screeding machine are to be transported, the support stands 48 may be readily attached to each end of the auger support beam 28 and may then support the screed head assembly at a support surface (such as in a container or the like) during transport of the screed head and/or screeding machine, while limiting or substantially precluding contact between the support surface and the vibrating member, auger and plow. Optionally, elastic rubber or rubber bumpers may also be optionally attached to the base portion 48a of the support stands 48 to provide additional non-slip capability and cushioning for the screed head assembly when it is supported at a support surface by the support stands.

CONTROL SYSTEMS

[0068] The present invention also provides enhanced performance and control of the screeding machine. With reference to FIGS. 33A-E, an operator's platform or station 50 of screeding machine 10 may include an operator's seat 52, with a left control panel 54a and left joystick controller 56a at the left side of the operator's seat 52 and a right control panel 54b and right joystick controller 56b at the right side of the operator's seat 52, whereby the operator can manipulate or control or adjust the switches and buttons and inputs at the control panels and joystick controllers to perform various functions and to select various control features of the screeding machine. For example, the screeding machine may include a boom speed cruise control system, boom limit switches, an auto-stabilizer system, an auger/vibrator auto on/off system, a joystick steering system, an operator preference mode or auto-screed system, and a joystick swap system or feature, as discussed below. The operator's station may include a display 58 for displaying information to the operator during operation of the machine, as also discussed below.

Boom Speed Cruise Control

[0069] As mentioned previously in the example above, there is an identified need in the concrete screeding industry for a screeding machine (such as a LASER SCREED™ screeding machine) with a control system that can readily provide a repeatable and consistent screeding control functions, such as screed head travel speed (i.e. boom retraction speed) to the operator while screeding concrete. Screeding machines typically include a telescopic boom assembly that supports a screed head assembly over an area of concrete to be screeded. The boom is extended and retracted by means of a hydraulic cylinder mechanically attached to the largest of the boom sections and the upper frame portion of the machine. An electronically-controlled proportional control valve controls the flow of hydraulic oil into and out of the boom cylinder. The proportional control valve is controlled by the amount of electrical current it receives from

an electro-hydraulic hand control lever or joy-stick controlled by the operator. An electronic controller accurately controls the current based upon the position or setting in which the operator places the variable hand control lever or joy-stick.

[0070] The present invention may also include an electronic relative position sensor within the boom cylinder to sense the relative position and relative speed of extension and retraction of the boom cylinder rod and piston assembly. Typically, the operator manually adjusts the travel speed of the boom and screed head by means of an electro-hydraulic control lever or joy-stick to achieve the desired travel speed of the screed head while screeding concrete. During actual screeding operations, the operator normally and manually adjusts and often repeatedly re-adjusts the travel speed of the boom and screed head by means of electro-hydraulic control levers or joy-stick to achieve the desired travel speed relative to the concrete being screeded.

[0071] The present invention provides an apparatus and method whereby the operator can depress the "Boom Speed Cruise Control" or "Screed Speed" button or switch or input (which, in the illustrated embodiment, and as shown in FIG. 33D, is included on the left side joy-stick controller of the machine). As shown in the control logic diagram of FIG. 34, an operator thus may set a stored speed or clear a stored speed by pressing the screed speed button with the left joystick controller pulled backwards (to retract the boom). Once the button is momentarily depressed, the machine control system receives and stores into electronic memory the present speed of the boom cylinder as it is being retracted by means of sensing the amount of current being provided to the proportional valve and the rate of change of the position sensor within the boom cylinder. Thereafter, and as needed throughout the day's screeding operations, whenever the operator desires to or is required to again repeat the desired boom retraction speed that has been stored in the machine's control system memory, the operator can simply and momentarily depress a single button (Boom Speed Cruise Control or Screed Speed) to automatically engage the desired and previously pre-set boom and screed head travel speed stored in the control system memory. When the operator wants to resume manual control, the operator may simply press the cruise control or screed speed button a second time or may press another button or input that is designated to disengage this control function.

[0072] Once the Boom Speed Cruise Control operational mode has been engaged, the operator can simply relax while maintaining a more relaxed grip on the joy-stick while simply holding it in a general and relative position, since the exact relative position of the controller is no longer critical toward maintaining the correct and desired boom and screed head travel speed. Should the operator simply let go of the joy-stick handle, the boom and screed head will instantaneously or substantially instantaneously stop through activation of a "dead man" switch

or trigger located within the grip of the handle. Additionally, the pre-set boom speed for Boom Speed Cruise Control mode can be readily changed or updated within the control systems stored memory by another single press of a button once the operator has identified a better or more preferred setting.

[0073] Thus the "Boom Speed Cruise Control" function and method for the screeding machine provides the operator with consistent and repeatable results while having to determine and reestablish the speed of the screed head during each screeding pass. The operator can readily store a boom retract speed for a screeding pass so that the operator can maintain a consistent boom retract and screed head travel speed throughout the entire pass and through multiple successive passes. At the end of a pass, the boom speed may clear or reset to manual control (such as in response to a boom extend signal or a timed button press and/or hold or the like), whereby the set or selected speed can again be selected by pressing the cruise control button at the start of the next pass so that the screed head is moved along the next pass at the selected or desired or appropriate or consistent speed.

[0074] The screed speed or cruise control feature and method can greatly reduce the cycle time of screeding operations, and may improve the overall control and productivity of the machine. An additional and further benefit is that this control feature helps to reduce the effects of operator skill and experience levels, operator fatigue, and typical screeding machine operational errors that may be often encountered.

Boom Propel Speed and Boom Cushion Switch

[0075] Optionally, and as shown in FIGS. 32A-C, the boom 14 may be extendable and retractable and may include a base or frame portion 14a, a large or intermediate boom 14b and a small or outer boom 14c. FIGS. 32A-C depict various degrees of extension of the boom of the screeding machine of the present invention, with a propel limit switch 15a and a boom cushion switch 15b for controlling full extension of the booms and the travel speed of the machine during operation of the screeding machine of the present invention. The propel speed of the machine may be reduced or limited when the boom is at or near its fully retracted position (such as within four feet of its fully retracted position as shown in FIG. 32A), and the machine may have less or no propel speed restrictions when the boom is further out or fully extended (such as when extended more than four feet from its fully retracted position, and such as shown in FIGS. 32B and 32C).

[0076] The degree of retraction of the boom may be detected by the boom propel switch 15a, whereby the switch detects when the boom has retracted a threshold amount (such as, for example, within about four feet or within about 20 percent of its fully retracted position) and

the propel speed of the machine may be automatically adjusted or reduced or limited in response to actuation of or triggering of the boom propel switch 15a. In a somewhat similar manner, the boom cushion switch 15b may detect when the boom nears its fully extended position (such as shown in FIG. 32C), and the extension speed of the boom may be automatically adjusted or reduced or limited (to slow and control the boom extension speed before the boom reaches its full extension mechanical limit) in response to actuation of or triggering of the boom cushion switch 15b. Thus, the machine propel speed and/or the boom extension speed may be controlled or limited or reduced as the boom approaches its maximum retraction or extension limits, in order to control the machine speed when the balance of the machine may be affected by the retraction of the boom and/or in order to control the boom propel speed when the boom is substantially extended to limit or avoid sudden stopping of the boom as it reaches its maximum extension limit or position.

Auto-Stabilizers

[0077] Screeding machines (such as the Somero LASER SCREED™ screeding machines) typically include four telescopic legs or stabilizers 24 located at each of the four corners of the lower frame portion of the wheeled unit 12 of the screeding machine 10. Each of the telescopic legs include a lower inner section and an upper outer section, whereby the upper outer section is structurally fixed and attached to the lower frame portion of the machine, while the lower inner section slides inside the upper outer section. Both the inner and outer sections are typically constructed of structural square steel tubing. A hydraulic cylinder (or other suitable linear actuator or the like) is attached at its respective ends to both the upper outer section and lower inner section, such that when the cylinder is either extended or retracted, the stabilizer leg extends and retracts.

[0078] The function of the four stabilizer legs is to provide rigid support of the screeding machine on the ground or support surface while the telescopic boom and screed head is extended outward over the surface of the concrete to be screeded. The four stabilizer legs can be controlled in unison or individually by the operator to accurately position the machine as to height elevation, levelness or slope with respect to the ground just prior to each screeding pass during concrete screeding operations. Typically, the operator manually adjusts the stabilizers by means of electro-hydraulic control levers or switches to achieve the desired height of the machine and the desired levelness or slope of the machine. The essential detail of these components was disclosed in U.S. Pat. No. 4,655,633, which is hereby incorporated herein by reference in its entirety.

[0079] The present invention is provided to include electronic relative position sensors included within each of the four hydraulic cylinders. These sensors (such as sensors commercially available from MTS Systems Corp. of Ottawa, IL) are able to sense the relative position between the inner rod and piston assembly of the cylinder and the outer tube or body of the cylinder. The relative extension or retraction position of each cylinder is electronically sensed, whereby each of the respective cylinder position signals is received by a specialized electronic controller included within the control system of the screeding machine. During actual operation and in preparation of the first screeding pass of a particular screeding job, the operator normally and manually adjusts the stabilizers by means of electro-hydraulic control levers or switches (such as shown in FIG. 35A) to achieve the desired height of the machine and the desired levelness or slope of the machine relative to the concrete to be screeded.

[0080] Next, the operator can depress the "Auto-Stabilizer" button included on the control console of the machine (FIGS. 33C and 35B). Once momentarily depressed, the machine control system receives and stores into electronic memory each of the four respective stabilizer cylinder positions. Thereafter, and throughout the day's screeding operations, whenever the operator is required to again set the position and levelness of the machine using the machine stabilizers he can simply and momentarily depress a single button (All Stabilizers – Extend) to automatically engage the stabilizers to the desired and previously pre-set positions stored in the control systems memory (FIG. 35C). Additionally, the pre-set positions can be readily changed or updated in the control systems memory by the single press of a button once the operator has identified a newer or more preferred setting.

[0081] In like fashion, when a predetermined position for raising each of the four stabilizers has been identified by the operator, a desired and previously pre-set position for the stabilizers in the retracted or raised position can also be set. This aspect is useful in that the operator can have the option of only partially raising the stabilizer legs off the ground – just enough to clear the ground while moving or driving the machine into position for the next screeding pass.

[0082] Thus, the operator may manually adjust the stabilizers to the desired position (this can be done using the two all-stabs switches (see buttons 1 and 2 of the right joystick controller in FIG. 33E) or the individual stabilizer switches (see switches 1 of the right control panel of FIG. 33C). The machine can be in an auto-stabilizers or manual stabilizers mode. The operator may select the auto-stabilizer mode by pressing the auto-stabilizers on/off switch (see switch 7 of FIG. 33C), and may press and hold the auto-stabilizers store settings switch (see switch 8 of FIG. 33C) to store an extend setting (by pressing the forward portion of the switch) or to store a retract setting (by pressing the rearward portion of the switch). The display at the

control panel may provide a visual and/or audible signal to notify the operator that the setting is stored. When the operator desires to use the machine defaults for extend or retract, the operator may again press and hold the store settings switch to return to the default settings. Optionally, the operator may return to manual control of the stabilizers by again pressing or toggling the auto-stabilizers on/off switch at the control panel. The display may show whether the auto-stabilizers function is on or off (active or disabled). When the auto-stabilizers function is off, the stabs extend buttons 1 and 2 on the right joystick controller (FIG. 33E) will control the stabilizers manually without any stored position settings being active.

[0083] To extend the stabilizers to the stored extension, the operator may press and hold the stabs extend button 1 on the right joystick controller (FIG. 33E), whereby the stabilizers will automatically extend to the stored position. Preferably, the operator need not hold the button during the entire extension, but may release the button (such as after one second) and the stabilizers will automatically continue to their destination or preset degree of extension. Pressing the button again or pressing the stabs retract button (button 2 in FIG. 33E) or pressing the auto-stabilizers on/off button will automatically stop stabilizer movement. To retract the stabilizers, the operator may use the stabs retract button (button 2 in FIG. 33E) in a similar manner.

[0084] Thus, the operator may set the stabilizers' extend or retract position at the beginning of the job. Following a button press from the operator, the stabilizers will extend or retract to the preset position. Using the individual stabilizer rocker switches, the operator can further adjust the stabilizers as necessary to account for differences in subgrade elevation. Optionally, the operator can use manual stabilizers if preferred. Optionally, the auto-stabilizers feature may have a default setting to be always off (disengaged) on machine startup, and/or the auto-stabilizers settings may not be affected or erased from memory when the machine is shutdown or the master switch is shutoff. Optionally, and desirably, the auto-stabilizers function may not work if one of the position sensors has malfunctioned, whereby the machine may automatically default to manual mode. Optionally, if the auto-stabilizers Extend/Retract Store Setting switch has malfunctioned, then the auto-stabilizers function may automatically use default settings for any automated stabilizer positioning.

[0085] Thus, the "Auto-Stabilizers" control function and method for the screeding machine provides the operator with consistent and repeatable results while having to re-set the position of the machine prior to each screeding pass, reduces the cycle time of screeding operations, and improves the control and productivity of the machine. The additional benefit is that this

feature helps to reduce the effects of operator skill and experience level, operator fatigue, and typical screeding machine operational errors that may be encountered.

Auger/Vibrator Auto On/Off

[0086] The screed head assembly of a screeding machine typically includes a plow for striking-off excess concrete, an auger for establishing the desired grade elevation of the concrete, and a vibrator or vibrating member to vibrate, consolidate, and smooth the concrete to a flat and accurately level surface. During each screeding pass while the machine is in operation, the auger 20 and vibrator 22, powered or actuated by their respective hydraulic motors, are manually turned off by the operator at the end of each screeding pass just as the screed head is lifted out of the concrete. As the boom and screed head are again extended out over the concrete prior to the next screeding pass, the auger and vibrator typically remain turned off. The reasoning for this is that since these functions are not essential to the operation of the machine at this point, essential hydraulic oil pressure and volume are made available to the portions of the hydraulic system that are in operation, thus increasing the speed and efficiency of the machine as a whole.

[0087] Once the boom and screed head are fully extended from the base unit, the screed head can be lowered by the operator by actuating the screed elevation down switches or by depressing the "Timed Lower" switch (such as switch or button 4 on the right side joy-stick handle of FIG. 33E), which initiates an automatic and controlled lowering of the screed head to the concrete surface where control by the machine's laser control system takes over (such as by utilizing aspects of the systems described in U.S. Pat. Nos. 7,044,681; 7,175,363; and/or 7,396,186, which are hereby incorporated herein by reference in their entireties). In typical manual control fashion, the operator must remember to turn the auger and vibrator on just at the ideal or correct instant as the screed head begins its descent for engagement with the concrete surface.

[0088] The present invention may include a control feature mode ("Auger/Vibrator Auto – On") whereby the auger and vibrator are automatically turned on whenever the "Timed Lower" switch is momentarily depressed by the operator at the beginning of each screeding pass. This control feature is helpful in that the operator does not have to remember to always turn on the auger and vibrator at the beginning of each screeding pass and at the ideal or correct point in time.

[0089] Once the boom has nearly fully retracted and screed head has reached the end of its screeding pass, the operator then momentarily depresses the "Timed Raise" switch which raises the screed head up out of the concrete. With the control feature mode (Auger/Vibrator

Auto –On) still active, the auger and vibrator are automatically turned off as the screed head rises out of the concrete. Again, this automatic control feature is helpful in that the operator does not have to remember to always turn off the auger and vibrator at the end of a screeding pass to conserve hydraulic system oil pressure and flow resources for the other hydraulic functions of the machine. As an additional control feature and benefit to the operator, the auger and vibrator may not be turned off right away, but may remain on for at least one second and preferably at least two seconds (such as approximately three seconds) after the "Timed Raise" switch is momentarily depressed. This delay is helpful in that any excess concrete that may adhere to the surfaces of the auger and vibrating members is more effectively shaken off as the screed head is lifted out of the concrete. This helps to keep the auger and vibrator components cleaner and as free as possible of any excess concrete during the operation of the machine. Additionally, by allowing an additional few seconds of auger and vibrator run-time while the screed head is raised up out of the concrete, any excess weight at the screed head due to any adhered excess concrete is reduced.

[0090] As a further benefit, the Auger/Vibrator Auto On/Off control mode can help to protect the auger and vibrating member from undesirable fluctuations in hydraulic system pressure and flow as other machine functions are operated. For example, a pressure spike in the machine's main hydraulic system can sometimes cause the vibrator speed to suddenly and temporarily increase beyond its intended design speed. This can typically occur between screeding passes when operating the machine's stabilizers or propelling the machine where full hydraulic system pressure is required. When the vibrator speed increases in this manner, it can often approach higher vibrational speeds and modes (or orders) of vibration that are not desirable toward the expected life and reliability of the entire vibrator assembly. Therefore, by engaging the Auger/Vibrator Auto On/Off control feature to the on mode, the reliability and life of the vibrating member can be increased without necessarily having to rely upon highly accurate and relatively more expensive hydraulic flow controls, while improving the performance and reducing the overall operating costs of the machine by increasing the useful life of the components.

[0091] For example, and with reference to FIG. 36, when the Auger/Vibrator Auto mode has been selected or switched to "on" (such as by pressing the Auger/Vibrator button 6 of the left joystick controller of FIG. 33D), the operator may press or select the "timed lower" function (such as by pressing the Timed Lower button 4 of the right joystick controller of FIG. 33E), whereby the auger and vibrator automatically turn on at the start of the screed pass. The auger and vibrator will also automatically turn off, such as after about 3 seconds, when timed raise

function is selected (such as by pressing the Timed Raise button 3 of the right joystick controller of FIG. 33E) and when the screed head is at the end of a screeding pass.

[0092] Thus the "Auger/Vibrator Auto On/Off" control function and method for the screeding machine provides the operator with consistent and repeatable results while automatically turning the auger and vibrator on and off prior to and at the end of each screeding pass, respectively. This control feature also reduces the cycle time of screeding operations, and improves the control and productivity of the machine. The additional benefit is that this feature helps to reduce the effects of operator skill and experience levels, operator fatigue, and typical screeding machine operational errors that may be encountered.

Joy-Stick Steering

[0093] Screeding machines (such as Somero LASER SCREED™ screeding machines) in the past have typically included a steering wheel at the operator's area for the sole purpose of steering the machine while it is being driven or propelled around the construction work site or between set-up and positioning of the machine during successive screeding passes. The system or apparatus of the present invention may eliminate the conventional hydraulically-actuated steering wheel on a screeding machine and may provide steering control by means of the right-side joy-stick control handle. The steering of the machine's four wheels thus may be controlled electronically by operator positional input at the joy-stick handle, the machine's electronic controller, and electrically controlled proportional hydraulic valves that control the flow of hydraulic fluid or oil to and from the four steering cylinders located on the machine's two drive axle assemblies.

[0094] The immediate benefits to the design of the screeding machine is that the operator can maintain more complete control of the machine while keeping both hands on the respective left and right joy-stick controllers for all phases of machine operation. Additionally, a typical steering wheel is no longer positioned directly in front of the operator blocking his view toward the front of the machine and the screed head either while screeding operations are underway or simply driving the machine. Even further, ingress and egress to and from the operator's seating position is substantially improved by elimination of the typical steering wheel and its associated control console and structural components. Complete control of the machine's steered wheels is accomplished by simply tipping the right-side joy-stick control handle either left or right to proportionally turn the machine's wheels either left or right.

[0095] In addition to the operator being able to see the steered position of the front wheels, the machine may include an on-screen electronic operator's display that may show the relative steering positions of all four of the machine's wheels. This may be accomplished by position

sensors located within each of the machine's four steering cylinders similarly described above with respect to the position sensors located inside each of the machine's stabilizer cylinders. These sensors are able to sense the relative position between the inner rod and piston assembly of the cylinder and the outer tube or body of the cylinder. The relative extension or retraction position of each cylinder is electronically sensed, whereby each of the respective steering cylinder position signals are received by a specialized electronic controller included within the control system of the screeding machine.

[0096] During actual operation and steering while driving the machine, the operator may simply tip the right-side joy-stick either left or right to steer the machine by means of the electro-hydraulic proportional control lever. The operator can watch the front wheels of the machine and also refer to the current position of the wheels by viewing the operator's display screen where representations of the steered wheel positions may be electronically shown. The relative position of the joy-stick within its range of travel matches the steered position of the wheels (with the respective hydraulic steering circuit solenoid valve being controlled proportionally with the joystick position).

[0097] Optionally, the joystick may have a friction hold during the steering function. This allows the operator to leave the joystick in the position that he or she would like and the wheels will stay in that selected or steered orientation. Optionally, the wheels may automatically realign (center) and stay in alignment when switching between steering modes.

[0098] Optionally, and desirably, a dead man switch on the joy-stick may also be engaged in order for the steering to function. This prevents the wheels from being steered if the joy-stick is simply bumped unintentionally by the operator or any other way.

[0099] The steering system may be provided with a mode switch offering the operator the choice of 2-wheel steering (such as front wheels only), 4-wheel steering (front and rear wheels are steered in opposite directions at the same time for minimum turning radius), and crab-steer (front and rear wheels are steered in like directions at the same time providing an oblique direction of travel left or right while driving the machine). Whenever the mode switch is changed back to 2-wheel steering from the other two modes, the rear wheels or non-steered wheels of the machine automatically realign or self-center to the straight position. This corrective movement of the rear or non-steered wheels may also be shown on the operator display screen.

[00100] The electronic steering system may provide the operator with the ability to reset, readjust, or otherwise re-align the centered or straight ahead steered position of both the front and rear axles. The system may also provide for an automated "self-calibration" set-up mode,

whereby the system can be set to automatically cycle the steering cylinders through their respective ranges of travel, determine and record the limits of travel positions, and accordingly store these positions in the controller's memory such that when the steerable limits are reached at the axles, the hydraulic system flow of hydraulic fluid or oil is quickly and proportionately reduced to prevent hard-stopping of the steering cylinders at their respective extreme ranges of travel.

[00101] Additionally, the steering system control characteristics can be readily checked or recalibrated by pressing a button once the operator has identified a need to update the steering control settings.

[00102] Thus, the "Joy-Stick Steering" control function and method for the screeding machine provides the operator with increased operator visibility and improved steering control over that of previous designs. It also provides consistent and repeatable steering results while having to re-set the position of the machine prior to each screeding pass, reduces the cycle time of screeding operations, and improves the control and productivity of the machine. The additional benefit is that the operator can keep his hands on the joy-sticks while operating the machine and this feature helps to reduce the effects of operator skill and experience level, operator fatigue, and typical screeding machine operational errors that may be encountered.

Auto-Screed Mode

[00103] Another screeding machine control improvement feature that can benefit the machine operator and improve productivity of the screeding machine relies upon the electronic control systems capability for setting and storing maximum desired function speeds for boom extend, boom retract, boom rotate (upper frame portion) left, boom rotate (upper frame portion) right, and screed head rotation left and right (counter clockwise and clockwise). For example, when the Auto-Screed Mode is engaged or on, each of the functions discussed above may be individually controlled up to a pre-set maximum speed value as determined by the operator. Accordingly, the specific maximum speed for that particular function has been assigned a particular value that the operator prefers or is more comfortable with as compared to the standard factory setting. Prior to engaging Auto-Screed Mode, the operator sets the desired values for each function by means of the operator electronic display screen and a selection of input control buttons on the display.

[00104] The screeding machine thus may be operated in either manual or preset mode. The manual mode allows the machine to operate at its maximum speeds, while the preset mode can be used to reduce the speeds of boom extend/retract, frame rotate and head rotate to speeds selected by the operator. With reference to FIG. 37, an operator may select the preset mode

(such as by toggling or switching the preset/manual mode switch 6 of the right control panel of FIG. 33C), whereby the boom extend/retract speeds, frame rotate speed and head rotate speed may be limited to the selected speeds as set or selected by the operator. The preset mode allows the operator to reduce these speeds to improve control and consistency between passes. The selected maximum speeds may be adjusted through the display functions or other user inputs. The operator may change modes at any time by toggling the present/manual mode switch.

[00105] A benefit of this machine control feature is that new and less experienced operators can select slower than standard factory speed settings for these various functions while gradually learning how to operate the machine. Alternately, highly experienced operators can elect to select speed settings that are potentially faster than the factory settings as their operational experience increases. Also, reducing the head rotate or swing speed allows an advanced operator to switch between modes to operate slower (with a preset lower speed) next to walls or columns and then fast again (at or near the speed's maximum speed) when desired. Reducing the boom retract speed increases boom controllability to ease the operation of the machine when desired. Switching the Auto-Screed Mode off simply returns the speeds of these functions back to the original factory settings assuming that the pre-set Auto-Screed settings were different from the original factory settings.

[00106] This control feature provides the operator with more consistent and repeatable results while having to determine and adjust the speeds of these machine functions during each screeding pass. This control feature can also improve and reduce the cycle time of screeding operations, and improve the control and productivity of the machine. An additional benefit of this feature is that the operator can readily adjust the operating characteristics of the machine and this feature helps to reduce the effects of operator skill and experience level, operator fatigue, and typical screeding machine operational errors that may be encountered.

Joystick Swap

[00107] Another screeding machine control improvement feature that can benefit the screeding machine operator and improve productivity of the screeding machine relies upon the electronic control systems capability for switching the functions of the respective left and right hand joystick control functions. A simple rocker-type switch (such as switch 10 of the left control panel of FIG. 33B) near the operator's seat allows the operator to simply swap the functions of the joy-stick controls (see FIG. 38). This feature is considered beneficial to operators who may be left-handed or have a preference for operating the machine according to their experience with operating other equipment. Optionally, and desirably, the joystick button layouts are

symmetrical between the left and right joystick controllers to ease the operator's determination of the function of the buttons on the joysticks when the functions have been swapped. The Joystick Swap switch is a momentary type switch whereby once the switch has been activated the joystick control functions are effectively reversed. The joystick control functions may be returned to their original or default settings by either pressing or actuating the swap button a second time or by turning off the machine. The joystick swap button may have a safety or lock on it to limit or substantially reduce the possibility of an operator inadvertently switching the joystick functions.

[00108] In the event that the machine is turned off and once again restarted at some point, the control system may revert back to the original joystick control settings. If the machine reverts back to the original settings, and if the operator should again prefer the reversed settings, a momentary activation of the Joystick Swap switch will again swap the left and right joystick functions.

[00109] Additionally, should a malfunction within of one of the joysticks occur, the Joystick Swap control function can be used to confirm the existence of a faulty function within the particular joystick controller. This feature can be an aid for equipment troubleshooting and can also allow the operator further control options to continue operation of the screeding machine in the event of a control malfunction or switch failure.

Auto Throttle

[00110] Optionally, the screeding machine may include an automatic throttle control that is operable to automatically increase or ramp the engine throttle to a high engine speed (such as about 2800 rpm) when a machine function is used, and to automatically decrease or ramp the engine throttle to a low engine speed (such as about 900 rpm) when the machine is idle for a threshold period of time, such as, for example, greater than about fifteen seconds. The operator can select either the automatic throttle control or a manual throttle control, as desired. Optionally, if the auto/manual throttle switch malfunctions, the machine may automatically default to the manual throttle mode. The benefits of such an automatic throttle control function is that the machine will have reduced noise, reduced emissions, and greater fuel economy as compared to the generally known machines in the mobile constructions machine industry.

Remote Auger and Vibrator Speed Adjust

[00111] Optionally, the screeding machine may include a remote auger and vibrator speed adjust function, where the operator may adjust a slider bar or other suitable input, such as at the display, to increase or decrease the auger and/or vibrator speeds. For example, the speeds may change as the slider bar is moved. Optionally, the operator may press or switch a button or

input to save the setting. The slider bars may adjust the auger and vibrator speeds for both the preset and manual speeds. Thus, the auger and vibrator speeds may be adjusted by the operator from the operator's station or platform and while the operator is operating the screeding machine.

[00112] Optionally, the slider bars may show a percentage of available speed, such as from 0 percent to 100 percent. The upper and lower limits may be set by the machine manufacturer for each machine, such as through a hidden menu in the display. These limits can be field adjusted as necessary to account for any hydraulic system changes.

Remote Valve Tuning

[00113] Optionally, the screeding machine may include a remote valve tuning function, where the operator may adjust an input, such as at the display, to tune the machine controls to a desired or appropriate setting depending on the operator preferences and/or the particular application of the machine. For example, a valve speeds menu is accessible within the display by using a key sequence, whereby accessing this menu allows the operator to fine tune the operating characteristics of the machine. For example, a slider bar may be adjustable to adjust the controls between 0 percent and 100 percent for each function. The initial target speed is typically around 50 percent, but each machine may be tuned differently and may have different default values stored. For example, the valves may be tuned to set desired boom extend and retract minimum speeds and/or propel forward and reverse minimum speeds and/or swing left and right minimum and maximum speeds and/or head rotate left and right speeds and/or stabilizer extend and retract speeds. Optionally, the respective hydraulic valves may be automatically tuned to calibrate the steering, which may allow a centering adjustment for the front/rear wheels and automatic speed tuning).

[00114] Therefore, the present invention provides a screeding machine for screeding placed concrete at a support surface. A screeding machine in accordance with the present invention may include one or more of the features described herein and/or described in U.S. provisional application Ser. No. 61/149,092, filed Feb. 2, 2009, which is hereby incorporated herein by reference in its entirety. For example, a screeding machine of the present invention may include an auger height adjustment feature that allows for adjustment of the height of the auger without shims, and/or a tip-to-clean feature that allows for enhanced tipping or rotating of the screed head to enhance the cleaning of the screed head at the end of a work day or after a screeding job is completed, and/or a screed head support beam that supports and encases a hydraulic manifold therein and allows for enhanced access to the manifold, such as via a swing-out manifold configuration, and/or a detachable transport stand for supporting the screed

head at a support surface when the screed head is removed from the boom or support beam, such as during transport of the screeding machine. Also, for example, a screeding machine of the present invention may include or provide various control features, such as a boom speed cruise control feature, and/or an automatic stabilizer control feature, and/or an automatic on/off control feature of the auger and vibrator of the screed head, and/or a joystick steering feature, and/or an operator preference mode where the operator can preset maximum speeds or the like for various functions so that the screeding machine speeds are limited to the selected speeds, and/or a joystick swap function, and/or a remote auger and vibrator speed adjust function and/or a remote valve tuning function. A screeding machine of the present invention thus may include or incorporate any one or more of the above configurations or features or functions or controls while remaining within the spirit and scope of the present invention.

[00115] Changes and modifications to the specifically described embodiments can be carried out without departing from the principles of the present invention, which is intended to be limited only by the scope of the appended claims as interpreted according to the principles of patent law.

CLAIMS:

1. A screeding machine for screeding a concrete surface having a partially cured concrete area and a newly placed concrete area, said screeding machine comprising:
 - a wheeled unit having a plurality of wheels for moving said wheeled unit over a support surface;
 - a screeding head assembly having a grade setting device and a vibrating member, wherein said screeding head assembly is movable over the concrete area via an extendable and retractable boom assembly extending from said wheeled unit;
 - wherein said screeding machine comprises at least one of:
 - (a) a boom speed cruise control for automatically controlling the travel speed of said screed head assembly during a screeding pass so that the travel speed of a first screeding pass of said screed head assembly is substantially the same as the travel speed of at least one subsequent screeding pass of said screed head assembly;
 - (b) an auto-stabilizer control that automatically adjusts the stabilizer actuators of said wheeled unit of said screeding machine to a preselected degree of extension in response to a user input;
 - (c) a control for automatically controlling the lowering of said screed head assembly toward and to the concrete surface and automatically activating said grade setting device and said vibrator at a beginning of a screeding pass and automatically deactivating said grade setting device and said vibrator in response to said screed head assembly being raised away from the concrete surface at the end of the screeding pass; and
 - (d) an auto-screed control that allows the operator to select a maximum value for at least one of a boom extension speed, a boom retraction speed, a boom rotation speed and a screed head rotation speed, whereby a respective speed of at least one of these functions of said screeding machine is limited to the selected value in response to the operator selecting an auto-screed mode.
2. The screeding machine of claim 1, wherein said screeding machine comprises a boom speed cruise control for automatically controlling the travel speed of said screed head assembly during a screeding pass so that the travel speed of a first screeding pass of said screed head assembly is substantially the same as the travel speed of at least one subsequent screeding pass of said screed head assembly.

3. The screeding machine of claim 2, wherein said boom speed cruise control, when activated, allows an operator to store a selected speed of said screed head assembly, whereby the operator can later actuate a user input to select to have said screed head assembly moved at the stored selected speed.
4. The screeding machine of claim 1, wherein said screeding machine comprises an auto-stabilizer control that automatically adjusts the stabilizer actuators of said wheeled unit of said screeding machine to a preselected degree of extension in response to a user input.
5. The screeding machine of claim 4, wherein said auto-stabilizer control allows an operator to actuate a user input to store a degree of extension of each of said stabilizer actuators, whereby the operator can later actuate a user input to cause said machine to automatically extend said stabilizer actuators to the stored degree of extension.
6. The screeding machine of claim 1, wherein said screeding machine comprises a control for automatically controlling the lowering of said screed head assembly toward and to the concrete surface and automatically activating said grade setting device and said vibrator at a beginning of a screeding pass and automatically deactivating said grade setting device and said vibrator in response to said screed head assembly being raised away from the concrete surface at the end of the screeding pass.
7. The screeding machine of claim 6, wherein said control, when activated, functions to automatically activate said grade setting device and said vibrator as said screed head assembly is lowered toward the concrete surface and automatically deactivates said grade setting device and said vibrator a period of time after said screed head assembly is initially moved away from the concrete surface at the end of the screeding pass.
8. The screeding machine of claim 7, wherein said control automatically deactivates said grade setting device and said vibrator at least one second after said screed head assembly is initially moved away from the concrete surface at the end of the screeding pass.
9. The screeding machine of claim 1, wherein said screeding machine comprises an auto-screed control that allows the operator to select a maximum value for at least one function comprising at least one of a boom extension speed, a boom retraction speed, a boom rotation

speed and a screed head rotation speed, whereby a respective speed of said at least one of function is limited to the selected maximum value for said at least one function in response to the operator selecting an auto-screed mode.

10. The screeding machine of claim 9, wherein said auto-screed control is deactivated and said maximum values are reset to a default setting when said screeding machine is turned off.

11. A screeding machine for screeding a concrete surface having a partially cured concrete area and a newly placed concrete area, said screeding machine comprising:

a wheeled unit having a plurality of wheels for moving said wheeled unit over a support surface;

a screeding head assembly having a grade setting device and a vibrating member, wherein said screeding head assembly is movable over the concrete area via an extendable and retractable boom assembly extending from said wheeled unit; and

a joy-stick steering system that is operable to control the steering of at least two of said wheels, said joy-stick steering system providing an operator steering control of said at least two wheels by means of a joy-stick control handle, wherein the steering of said wheels of said screeding machine is controlled electronically by operator positional input at said joy-stick control handle.

12. The screeding machine of claim 11, wherein said joy-stick steering system includes an electronic controller and electrically controlled proportional hydraulic valves that control flow of hydraulic fluid to and from steering cylinders located at at least one drive axle assembly of said screeding machine, and wherein said electronic controller controls said hydraulic valves in response to a position of said joy-stick control handle.

13. A screeding machine for screeding a concrete surface having a partially cured concrete area and a newly placed concrete area, said screeding machine comprising:

a wheeled unit supporting a screeding head assembly having a grade setting device and a vibrating member, wherein said screeding head assembly is movable over the concrete area via an extendable and retractable boom assembly;

a right joystick control and a left joystick control for controlling respective functions of said screeding machine, wherein said right joystick control at least initially controls first functions and said left joystick control controls second functions; and

a joystick swap control that is actuatable by an operator of said screeding machine, whereby said right joystick control controls said second functions and said left joystick control controls said first functions in response to actuation of said joystick swap control.

14. The screeding machine of claim 13, wherein said respective functions comprise at least one of (a) a steering function, (b) a boom extension and retract function, (c) a screeding head control function, (d) a screeding head elevation control function, (e) a boom speed cruise control function, and (f) an auto-stabilizer control function.

15. A screeding machine for screeding a concrete surface having a partially cured concrete area and a newly placed concrete area, said screeding machine comprising:

a screeding head assembly having an auger and a vibrating member for screeding the concrete surface, said screeding head assembly comprising auger bearings for rotatably supporting said auger; and

an adjustment mechanism that allows an operator of said screeding machine to change said auger bearings and said auger without having to adjust a height adjustment of said auger after reassembly of said auger bearings and said auger, whereby the auger height adjustment settings are maintained without any readjustment.

16. The screeding machine of claim 15, wherein said adjustment mechanism includes a height adjustment retaining element that is adjustable to allow for adjustment of the height of said auger, and wherein the auger height adjustment settings are maintained so long as said height adjustment retaining element is not loosened.

17. A screeding machine for screeding a concrete surface having a partially cured concrete area and a newly placed concrete area, said screeding machine comprising:

a screeding head assembly having an auger and a vibrating member for screeding the concrete surface, said screeding head assembly comprising auger bearings for rotatably supporting said auger; and

a pair of detachable transport stands for supporting opposite ends of said screed head assembly at a support surface when said screeding machine is being transported.

18. The screeding machine of claim 17, wherein each said transport stand comprises a base portion and a generally U-shaped attachment portion for attaching at respective outer end regions of said screed head assembly.

19. The screeding machine of claim 18, wherein said transport stands are attached at said respective outer end regions of said screed head assembly via at least one retaining element that is inserted through generally aligned holes in said transport stand and said outer end region of said screed head assembly.

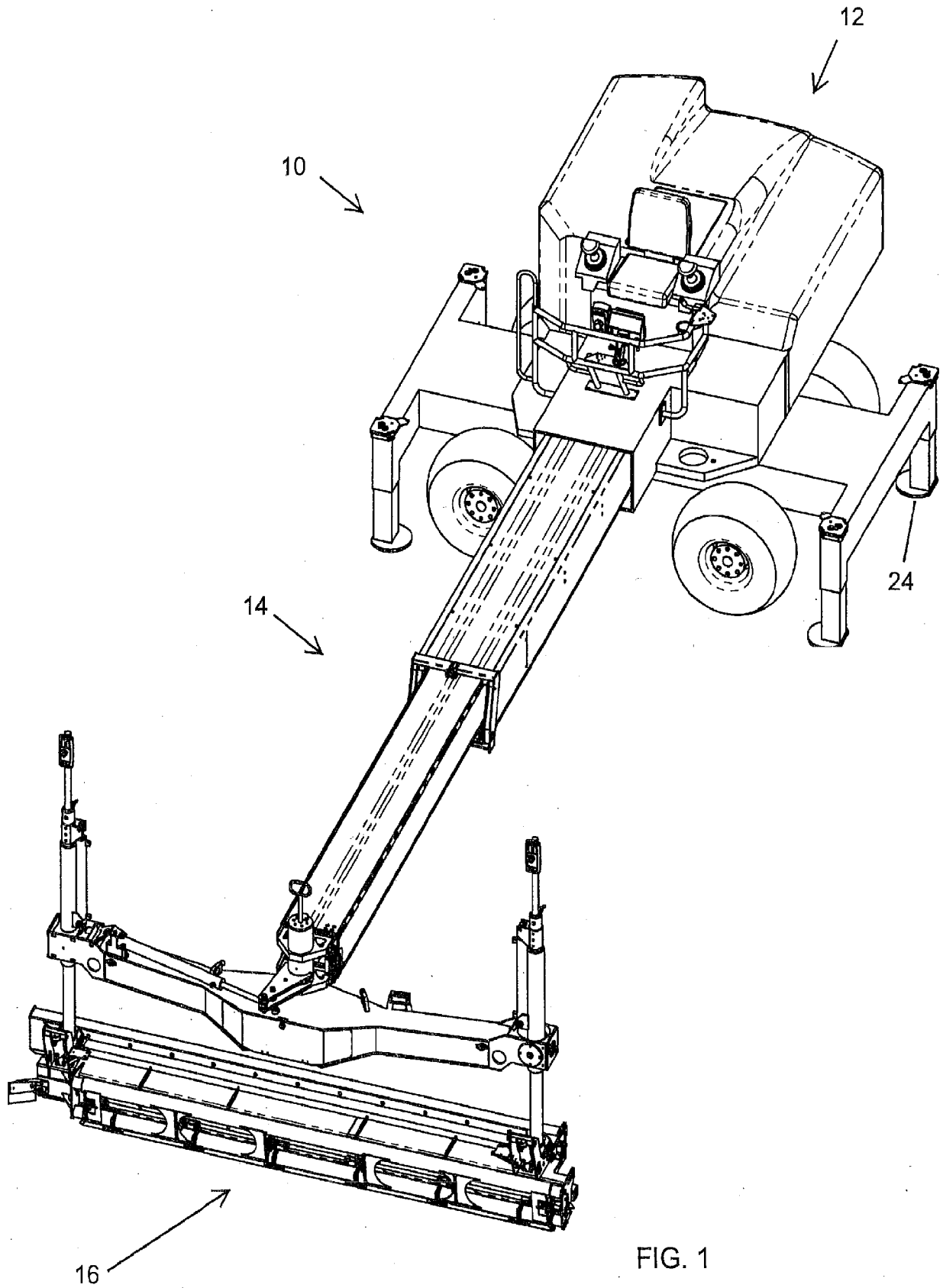

FIG. 1

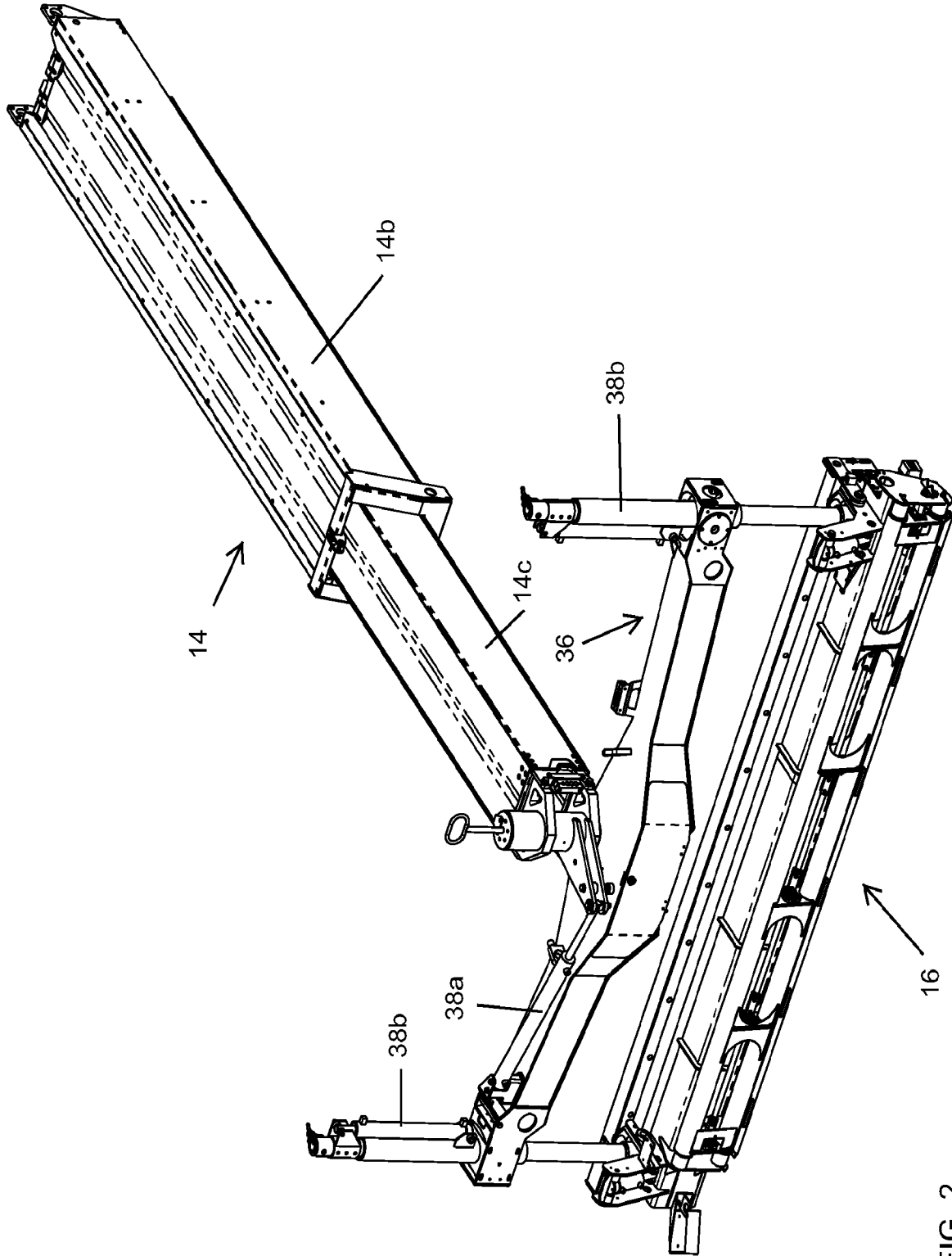
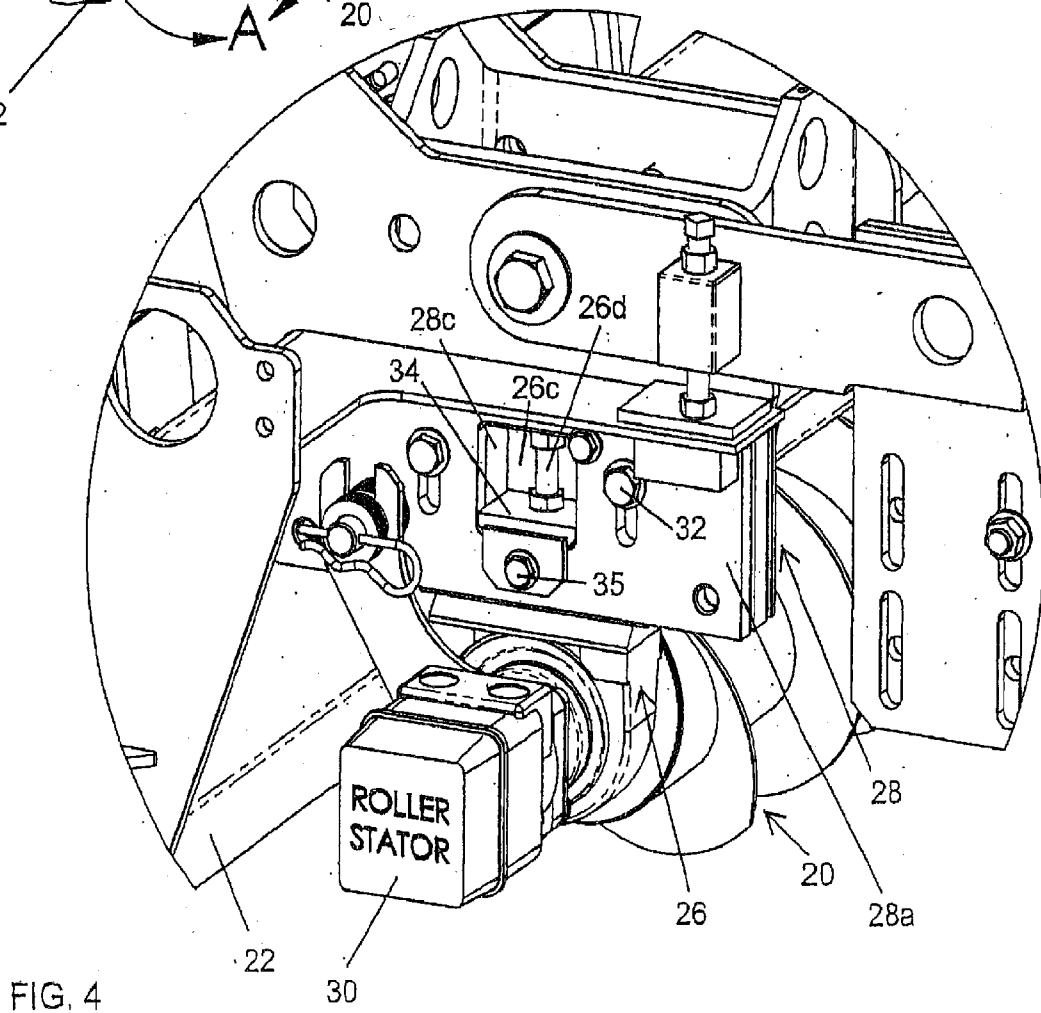
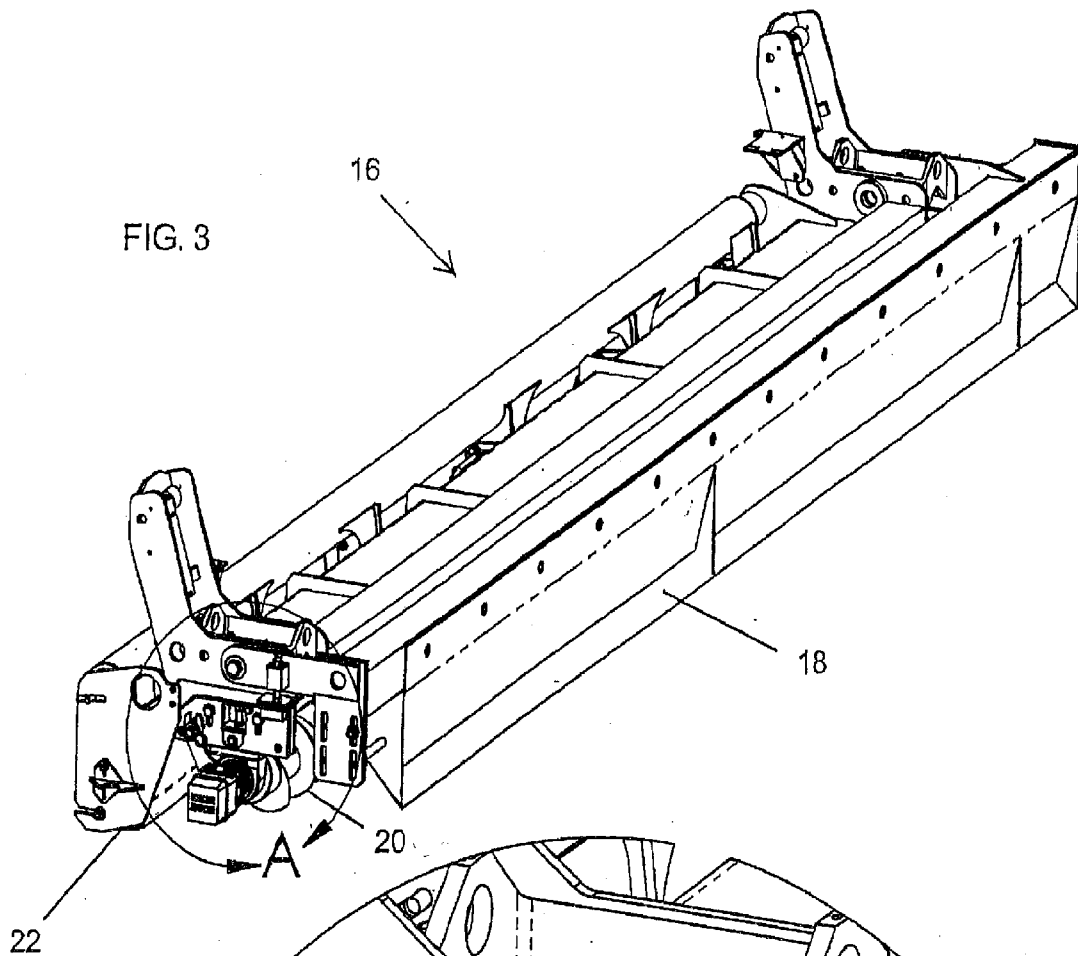
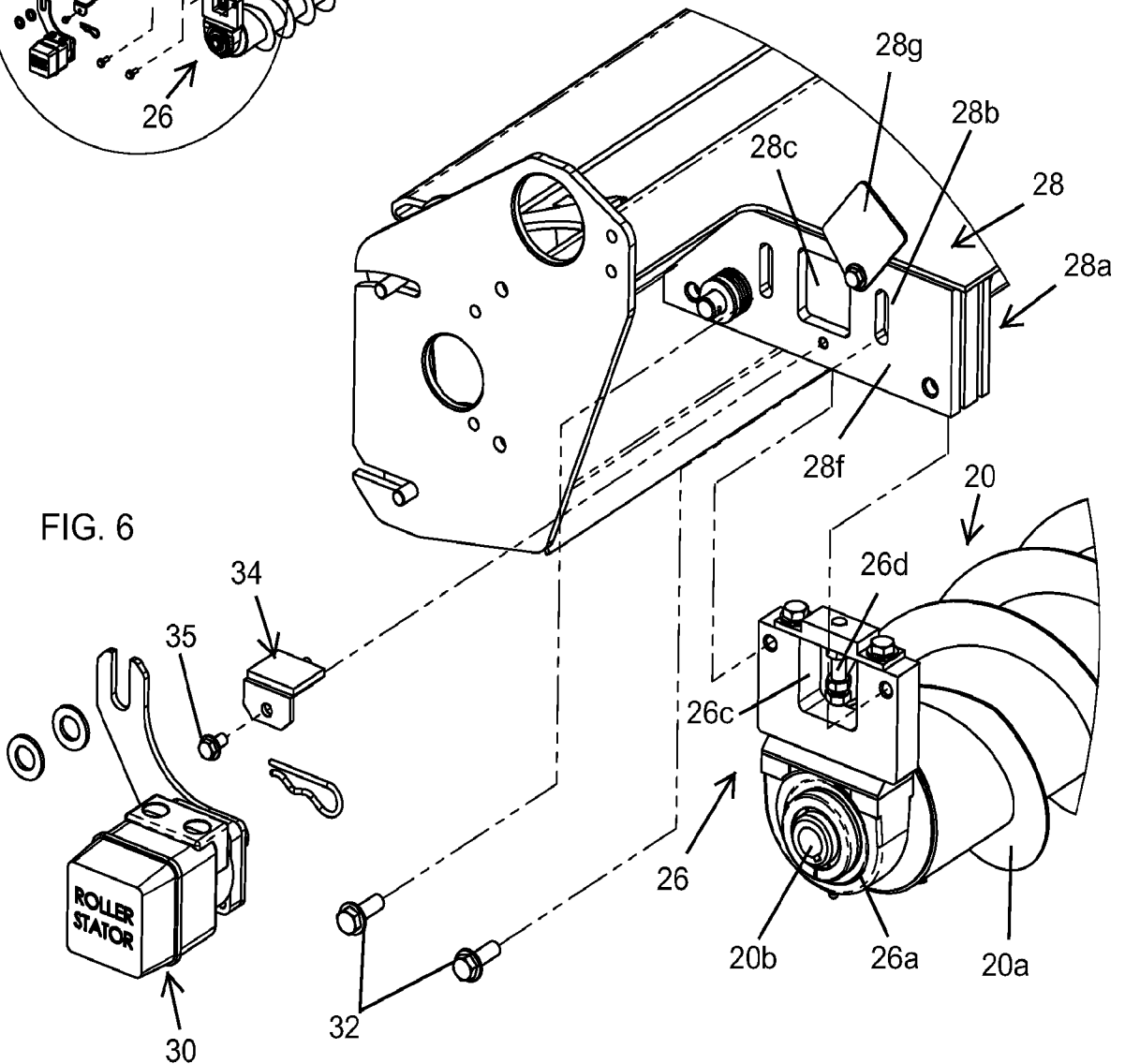
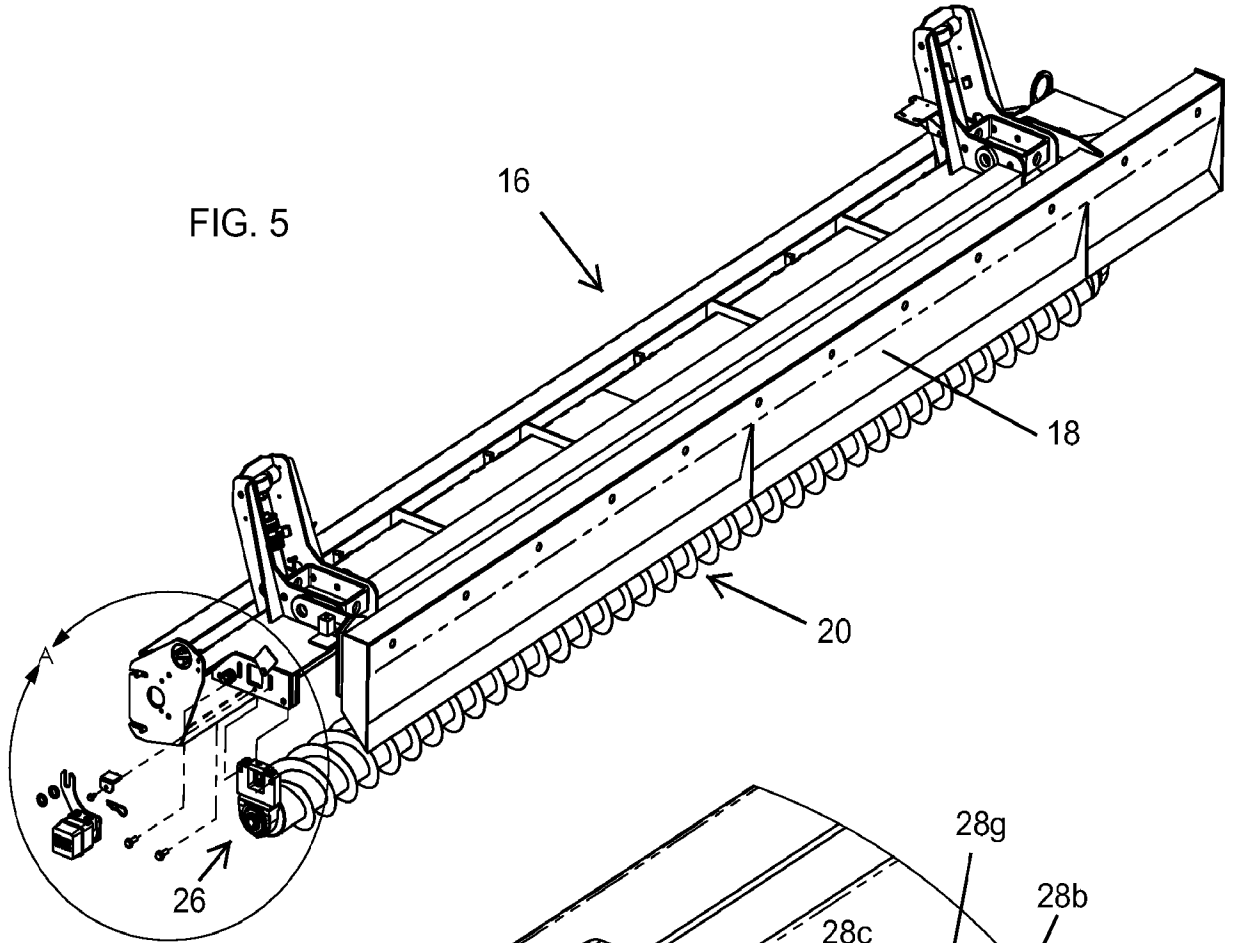

FIG. 2





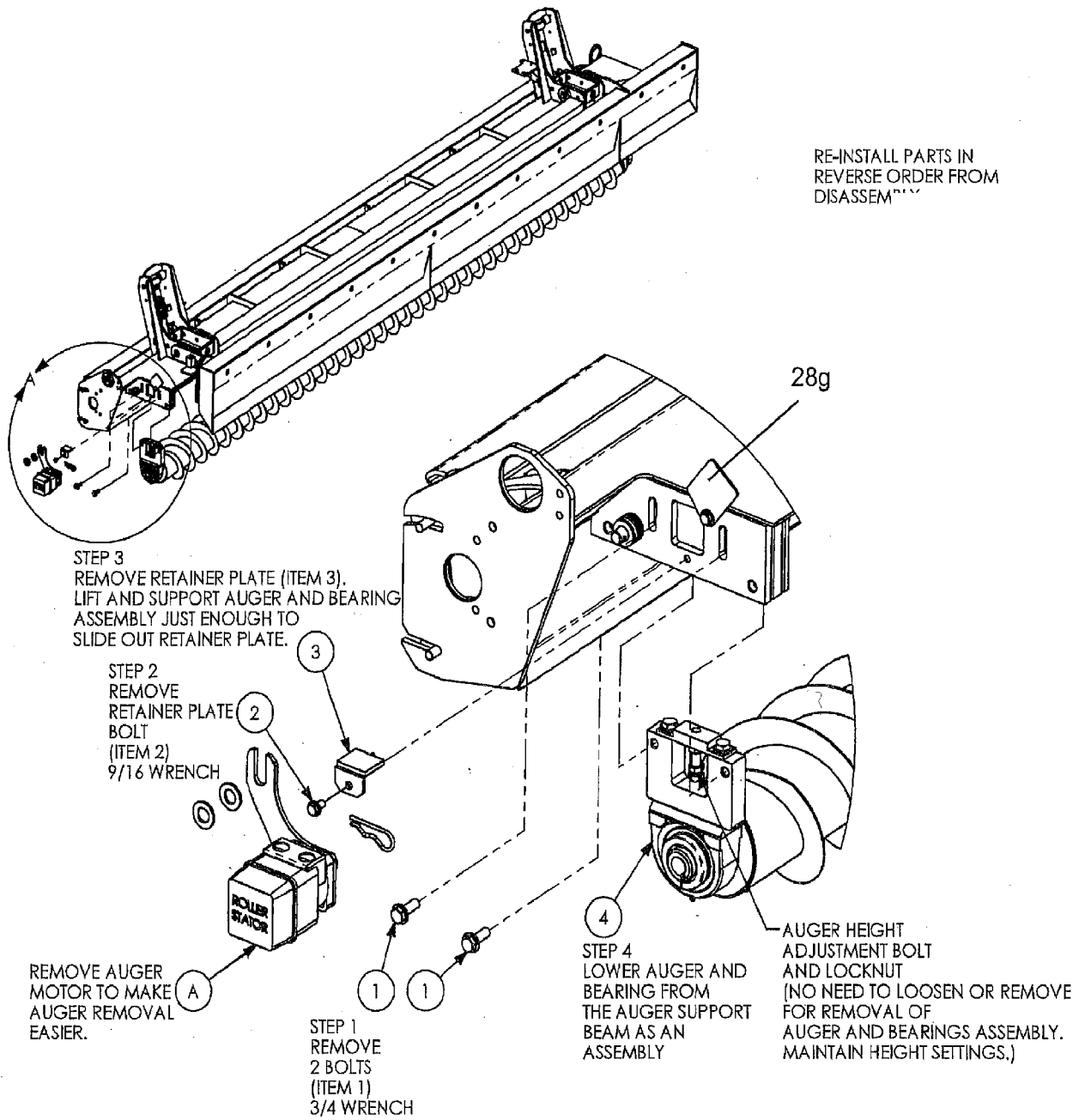

FIG. 7

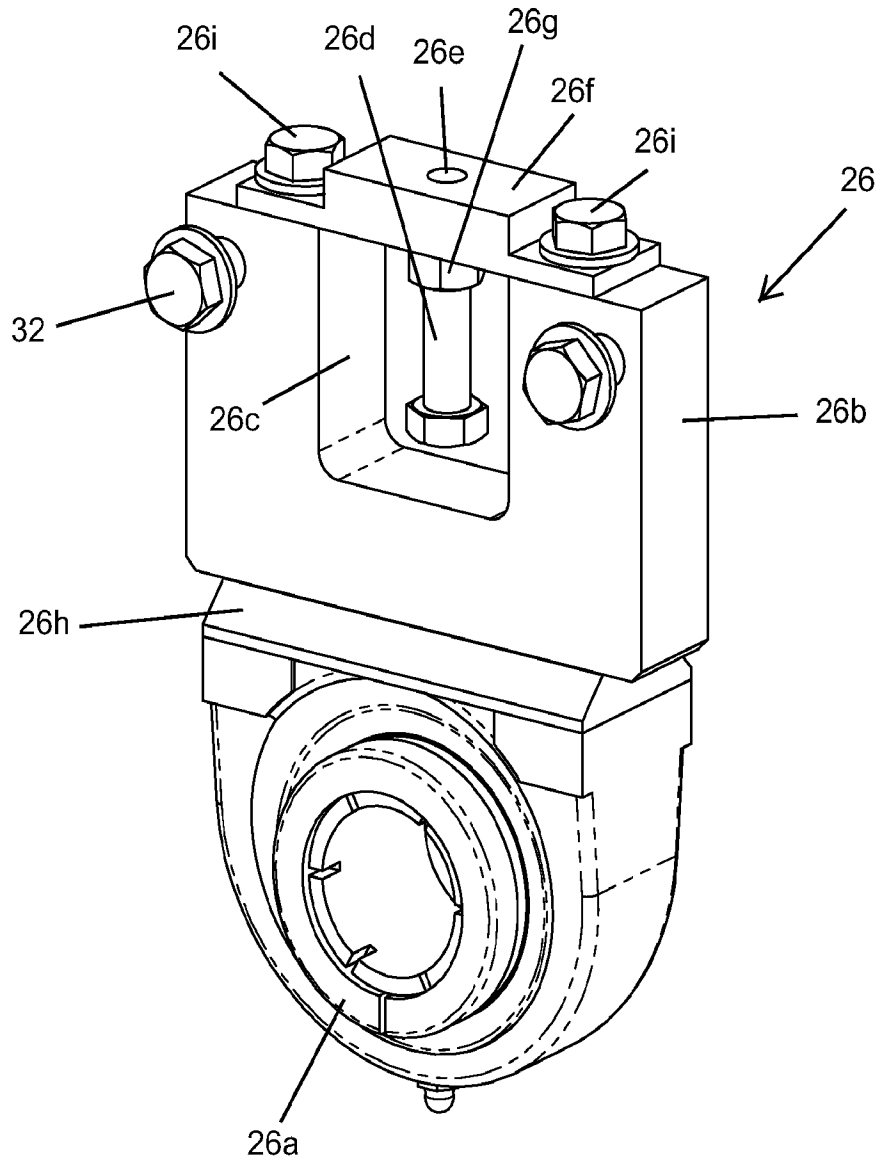

FIG. 8

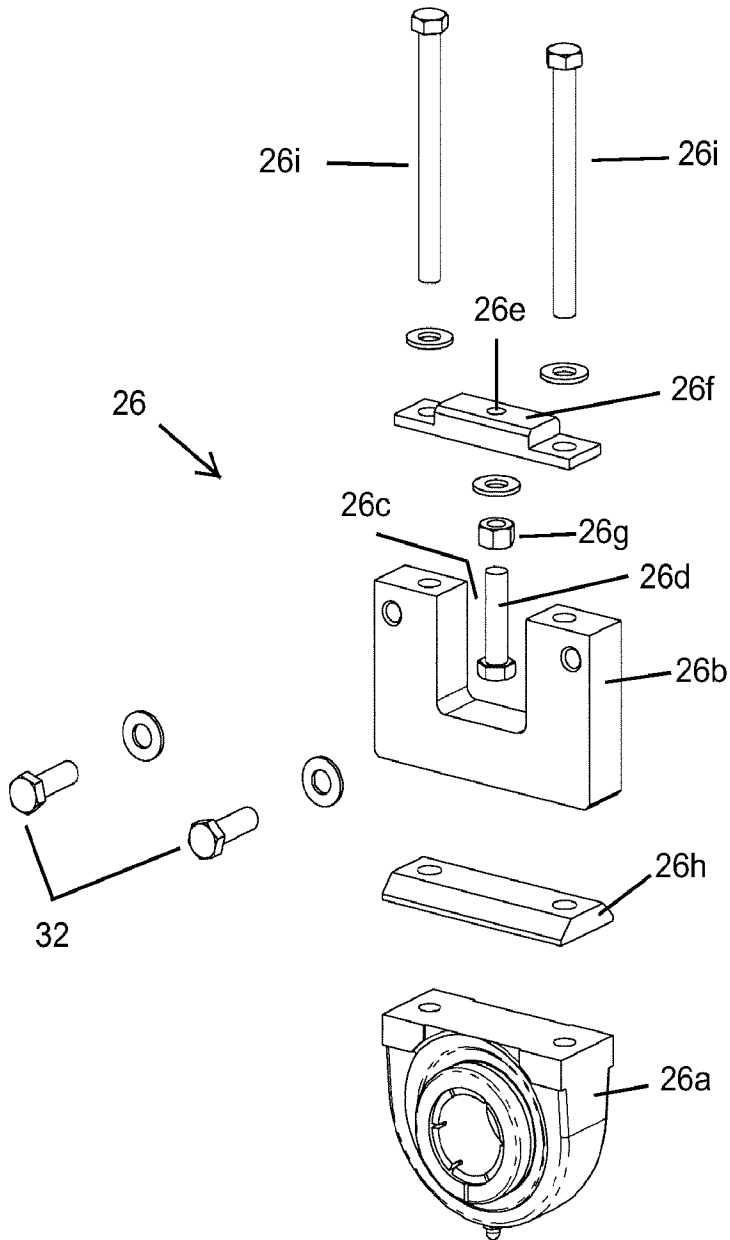

FIG. 9

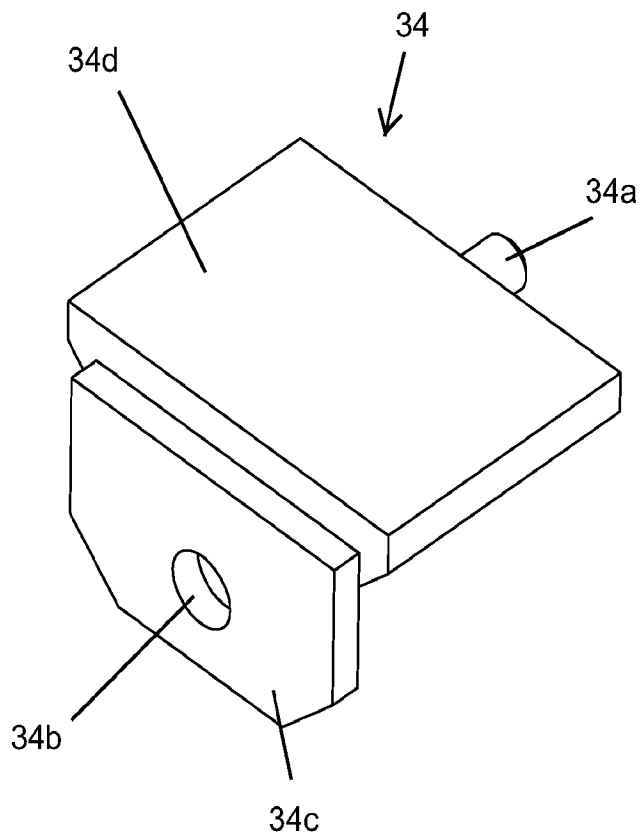

FIG. 10

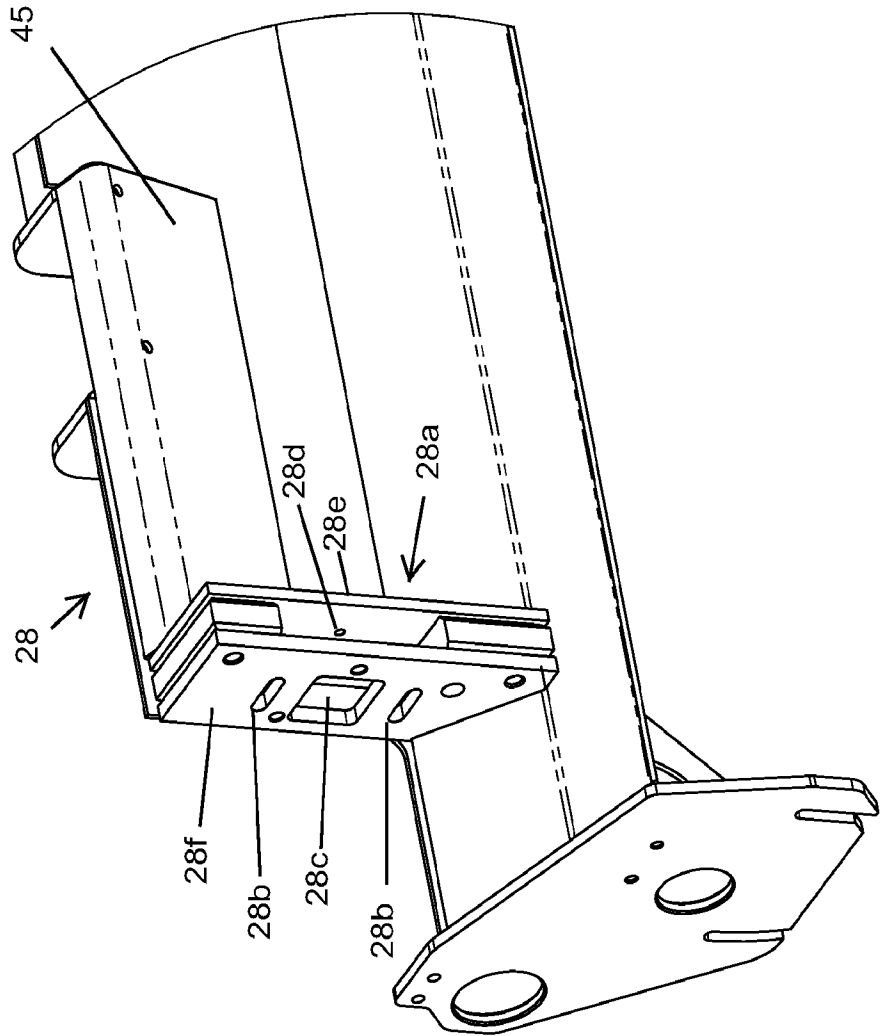
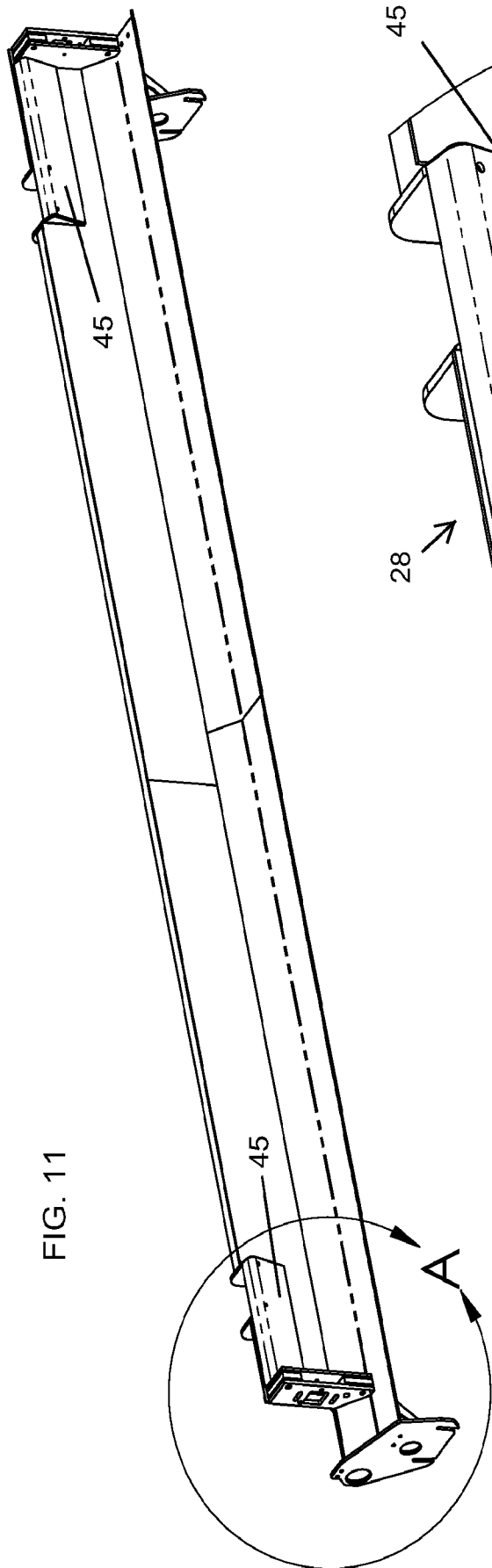

FIG. 14

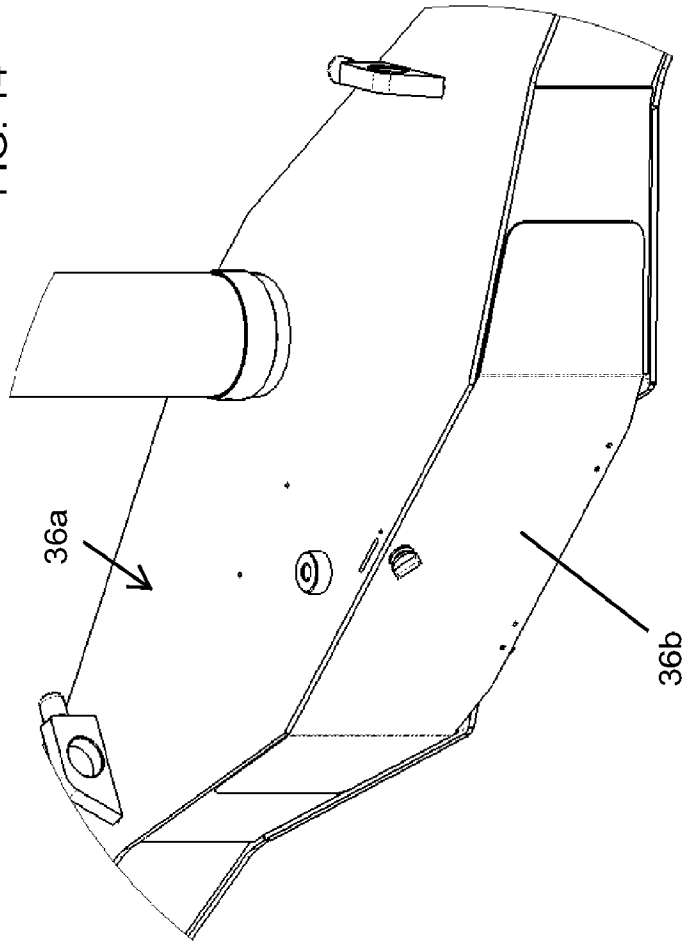
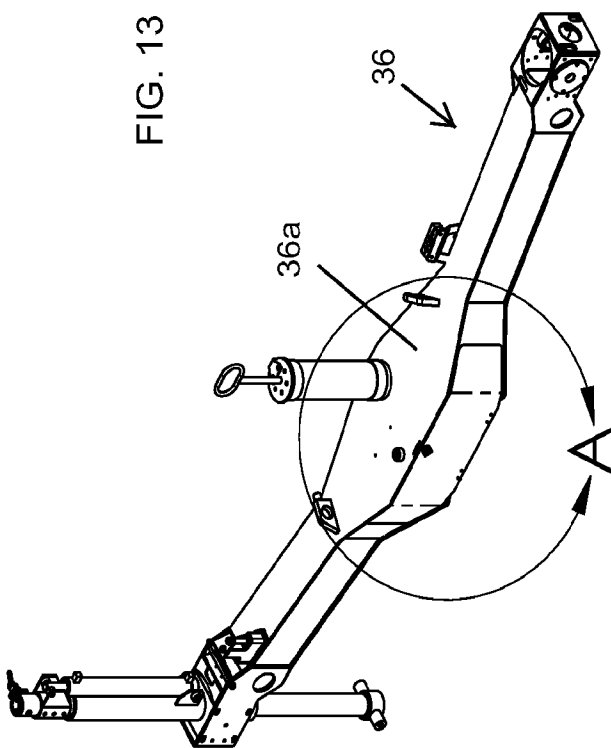
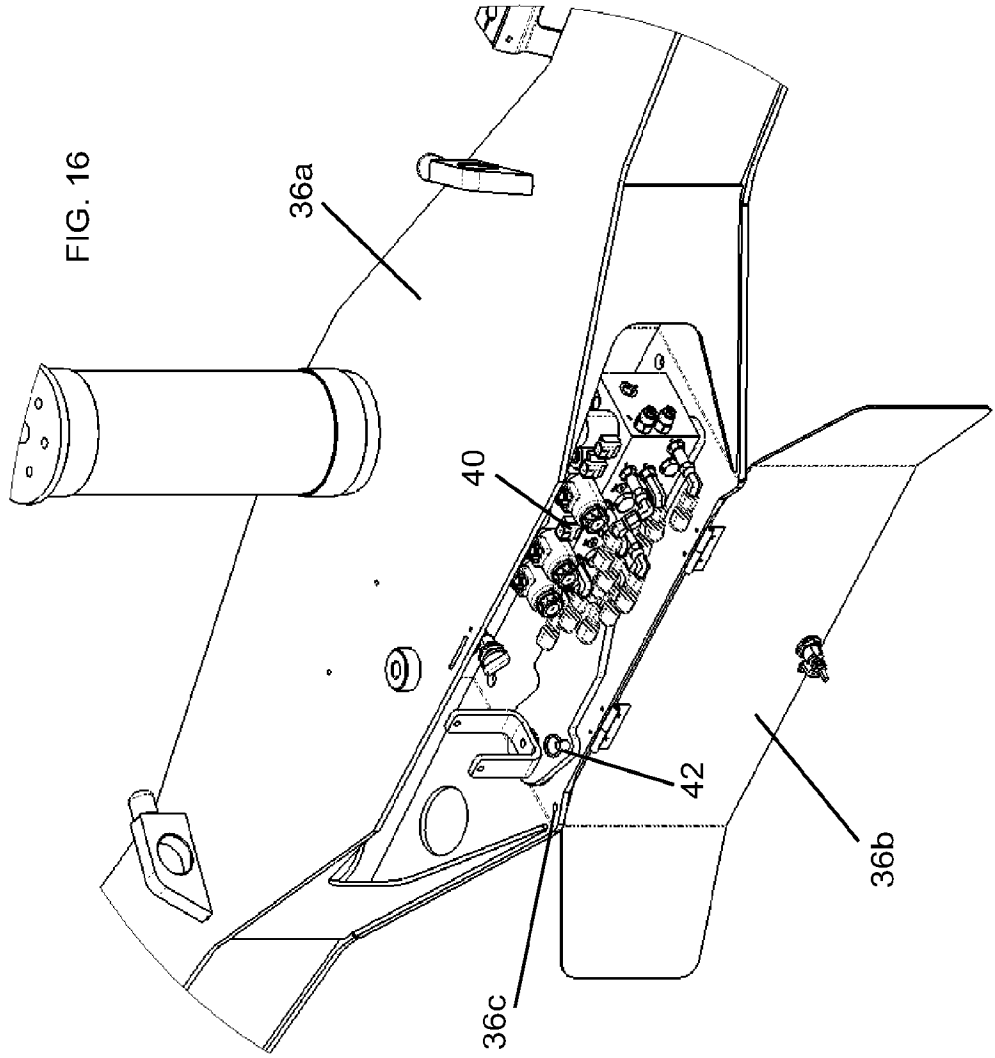
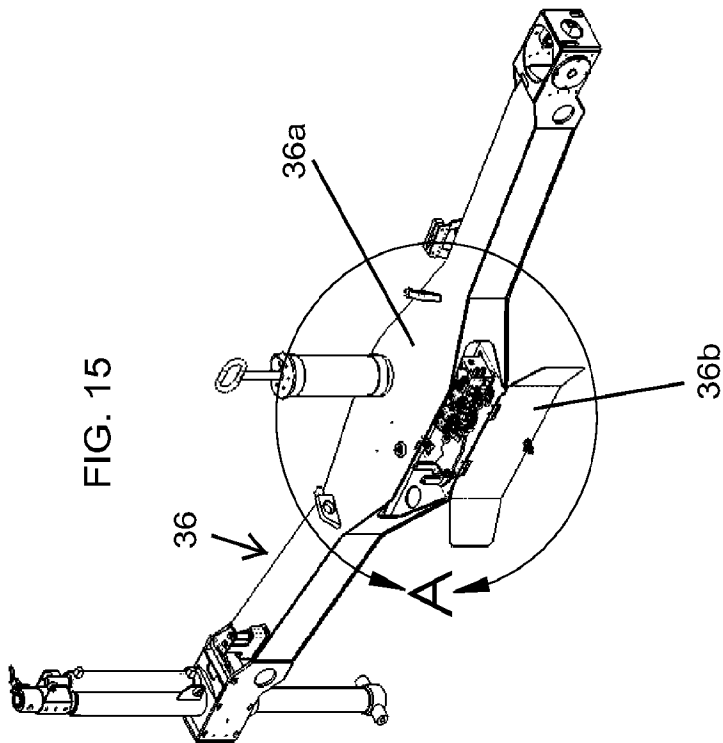

FIG. 13





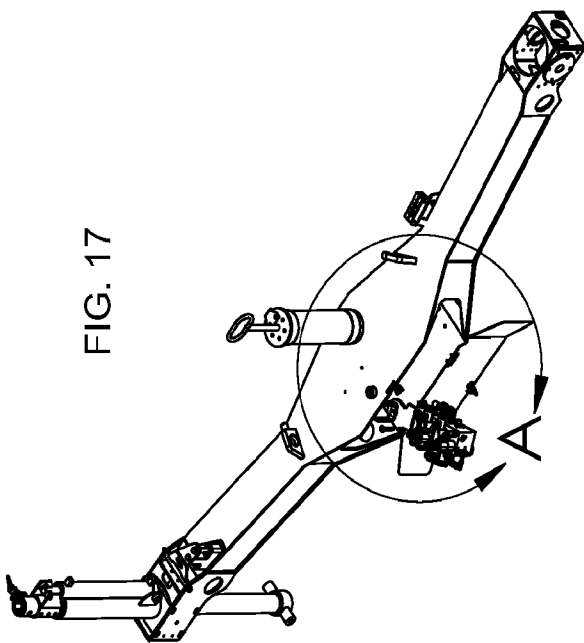

FIG. 17

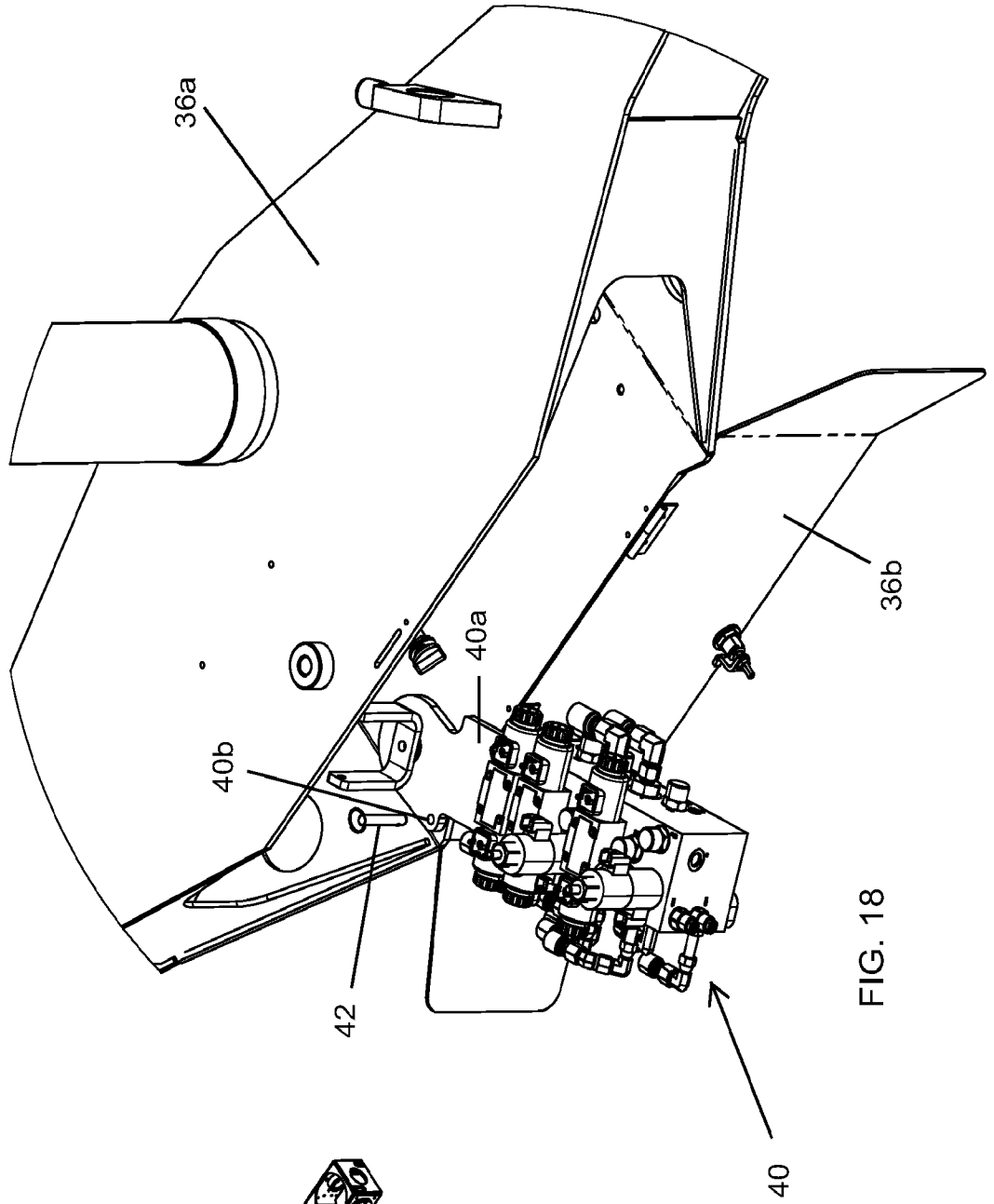

FIG. 18

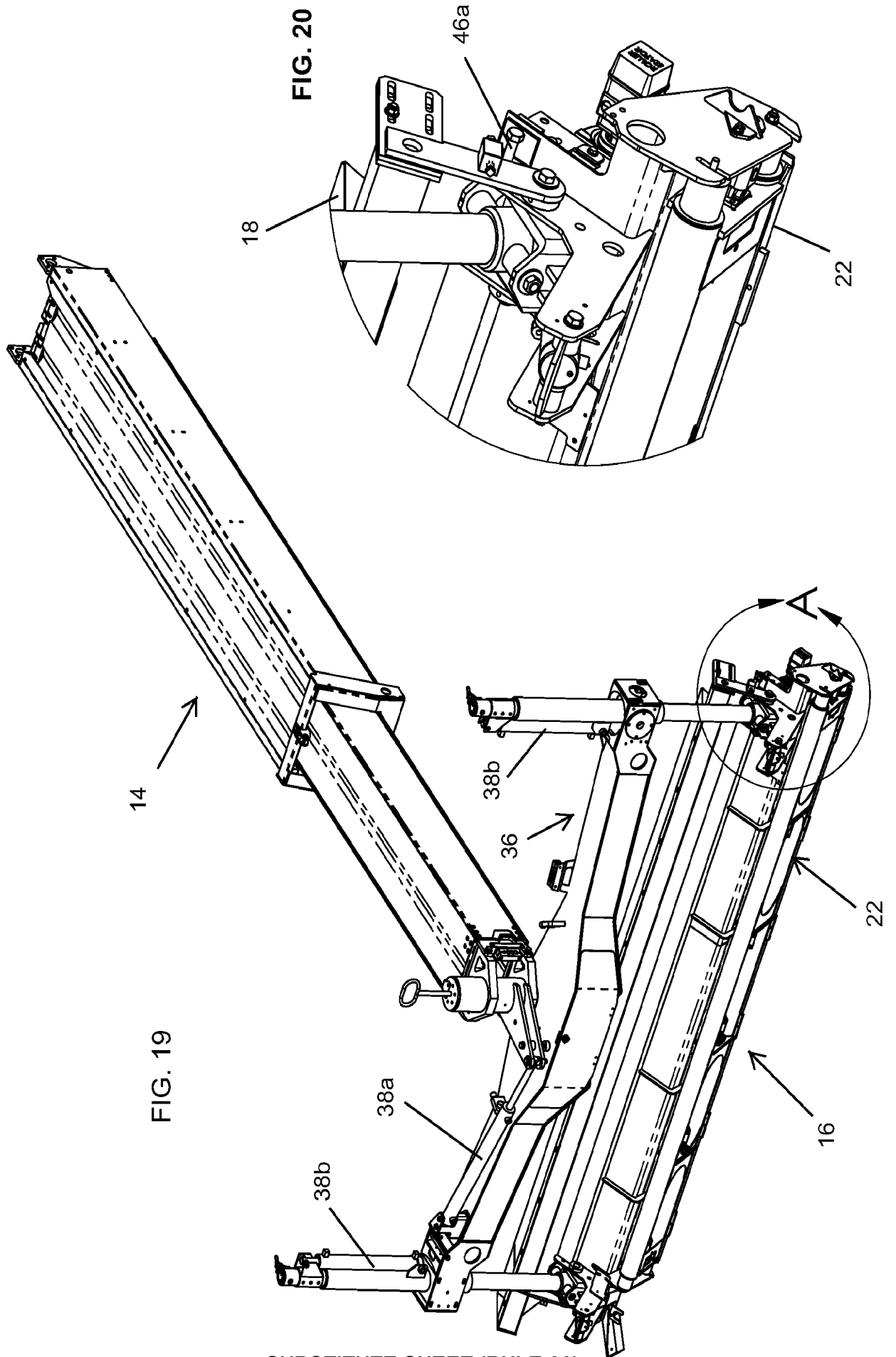

FIG. 19

FIG. 20

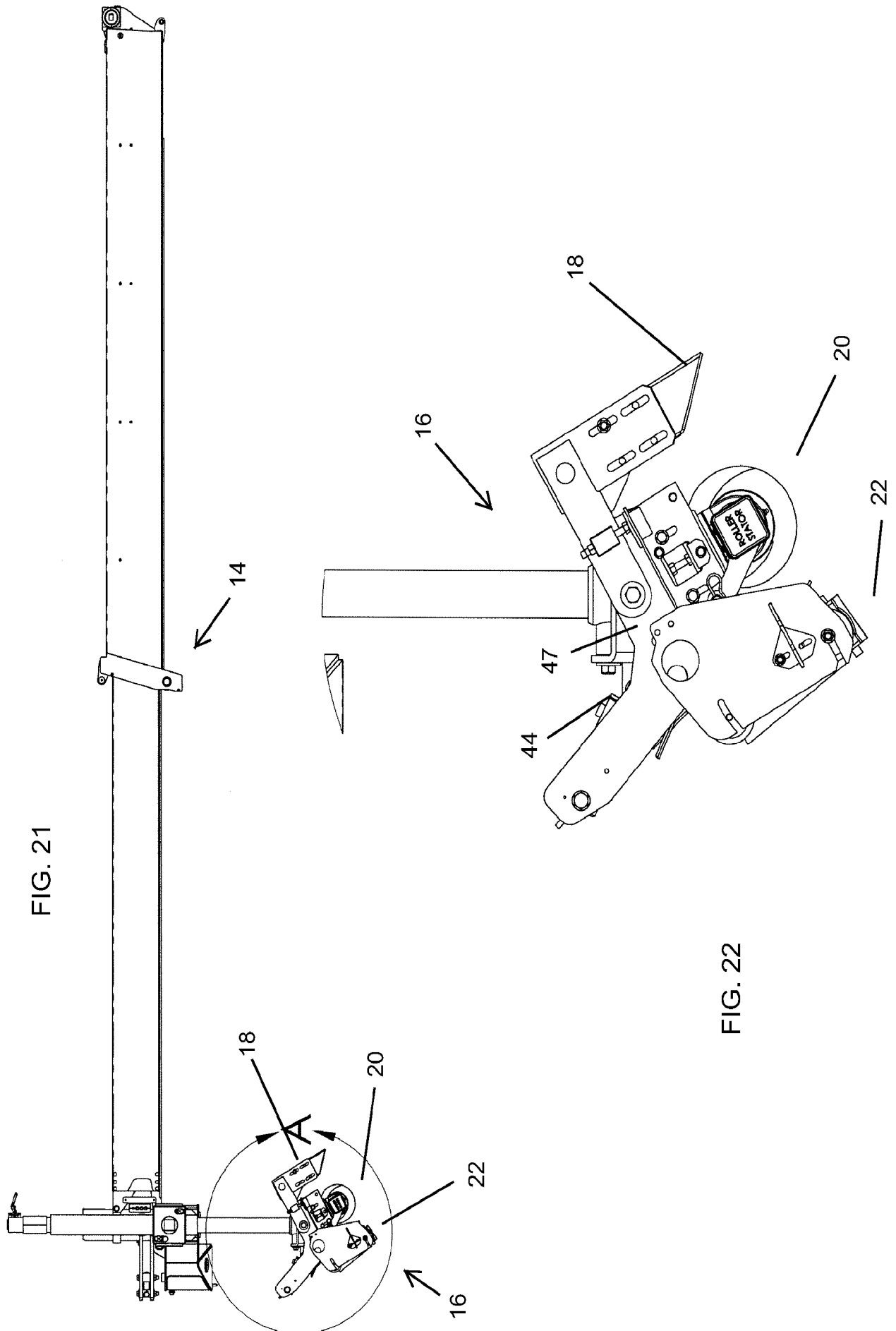

FIG. 21

FIG. 22

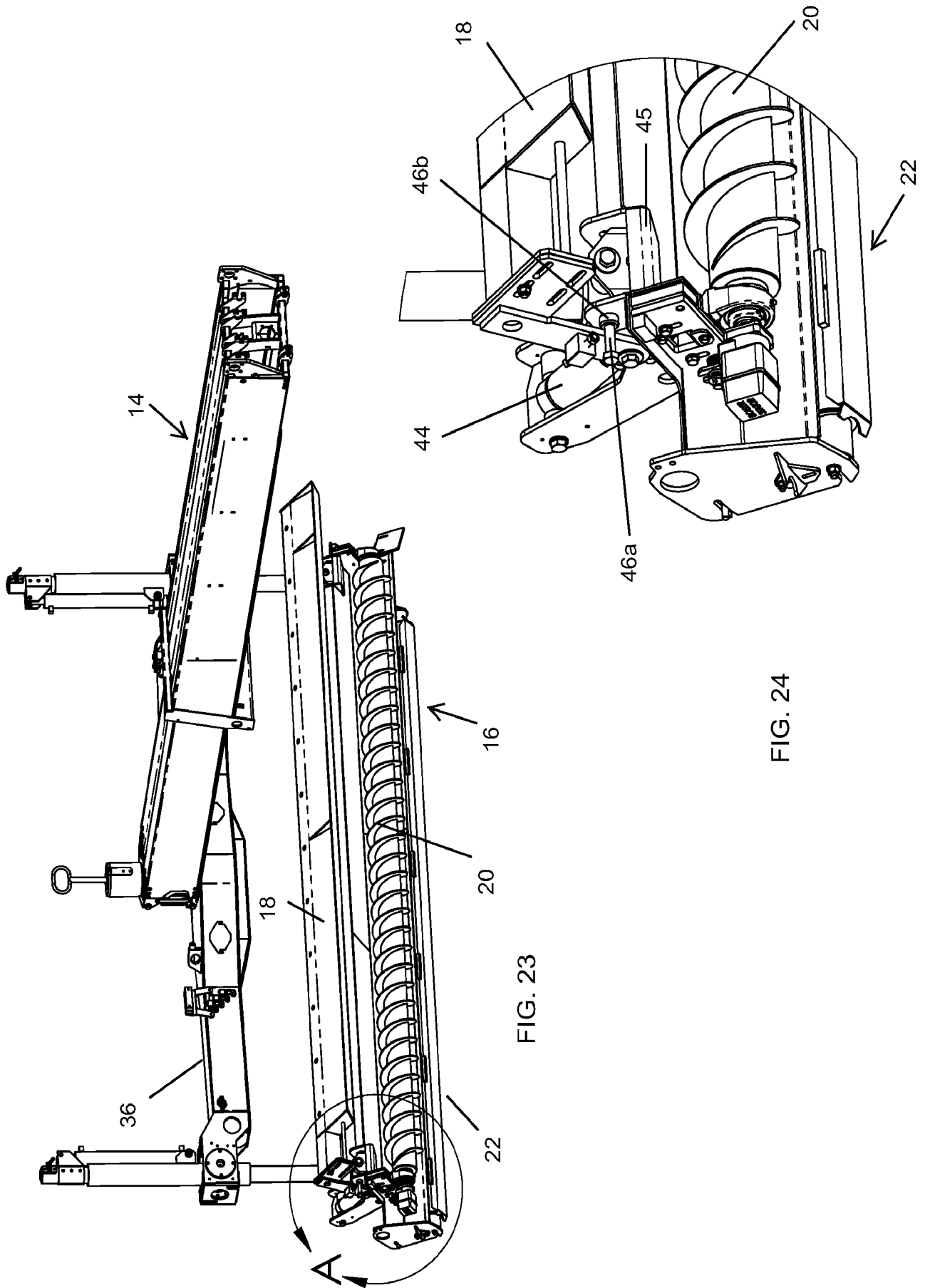

FIG. 23

FIG. 24

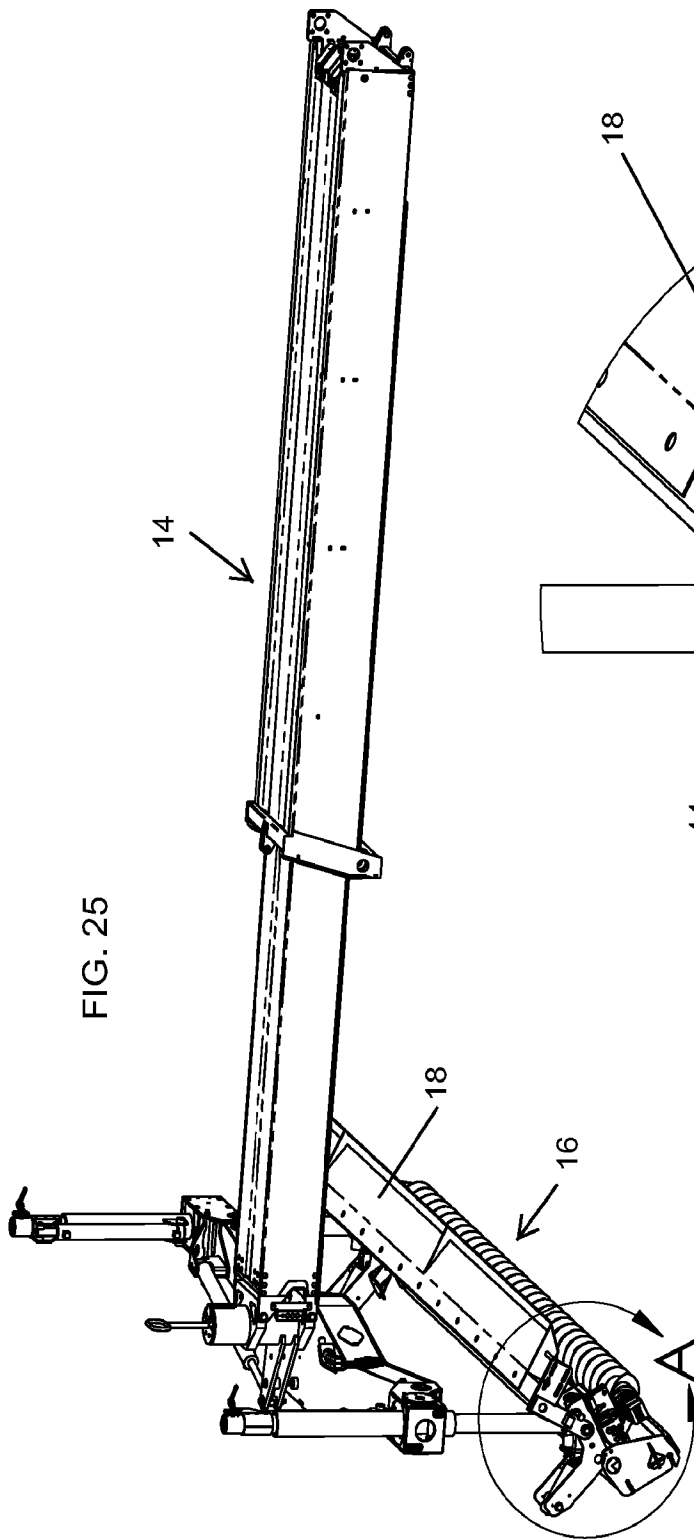

FIG. 25

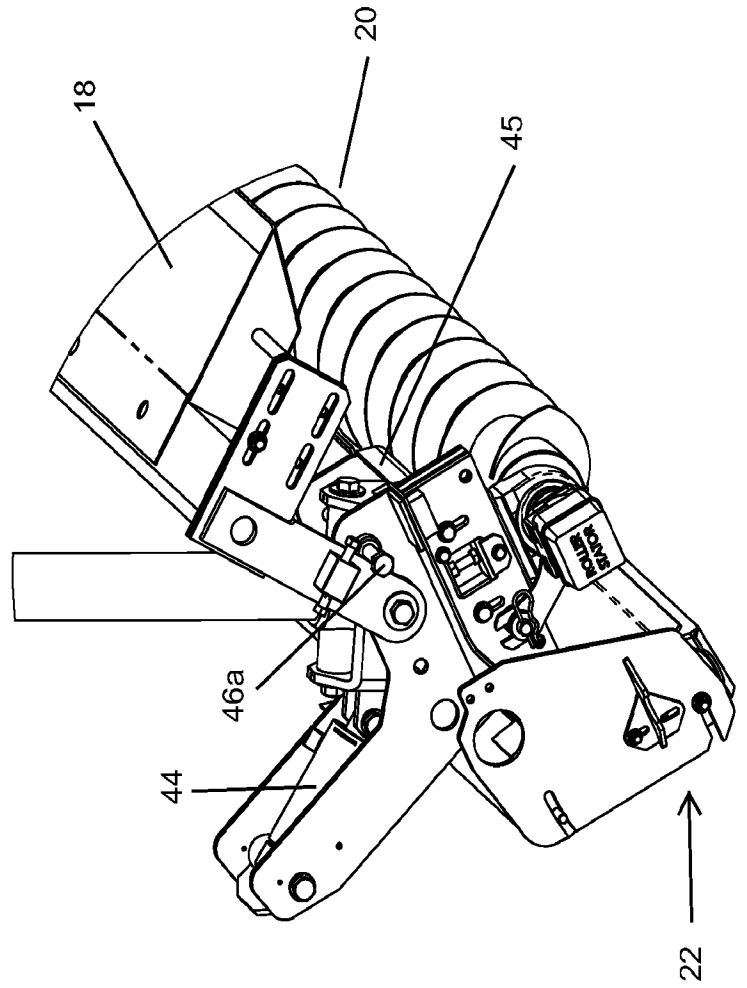
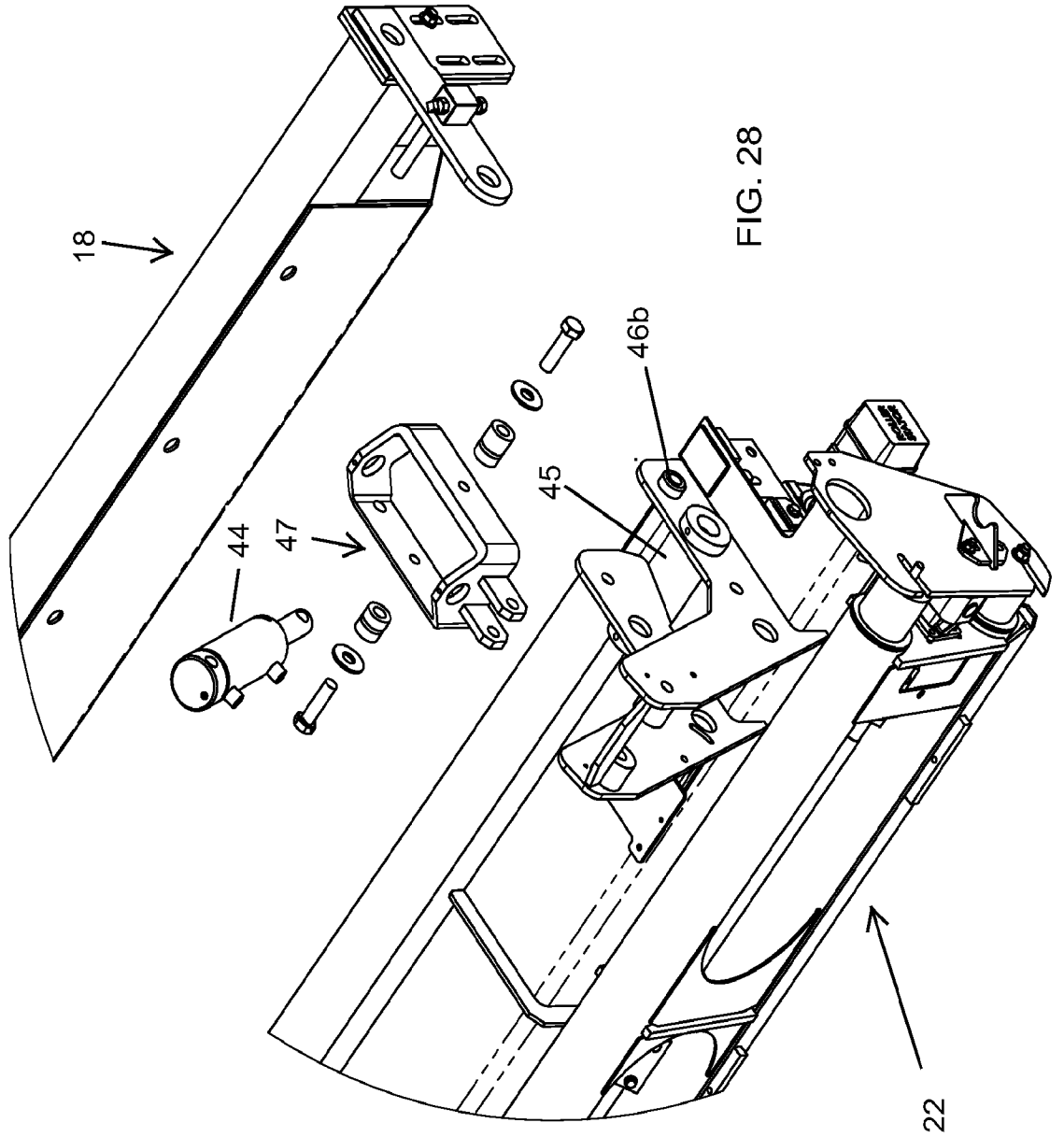
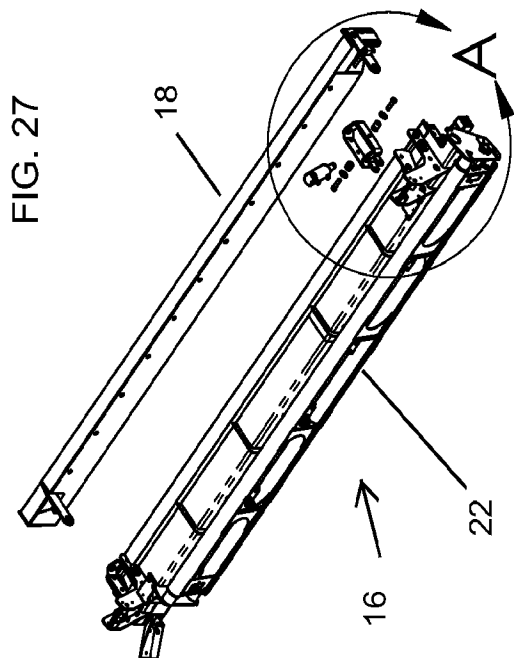

FIG. 26



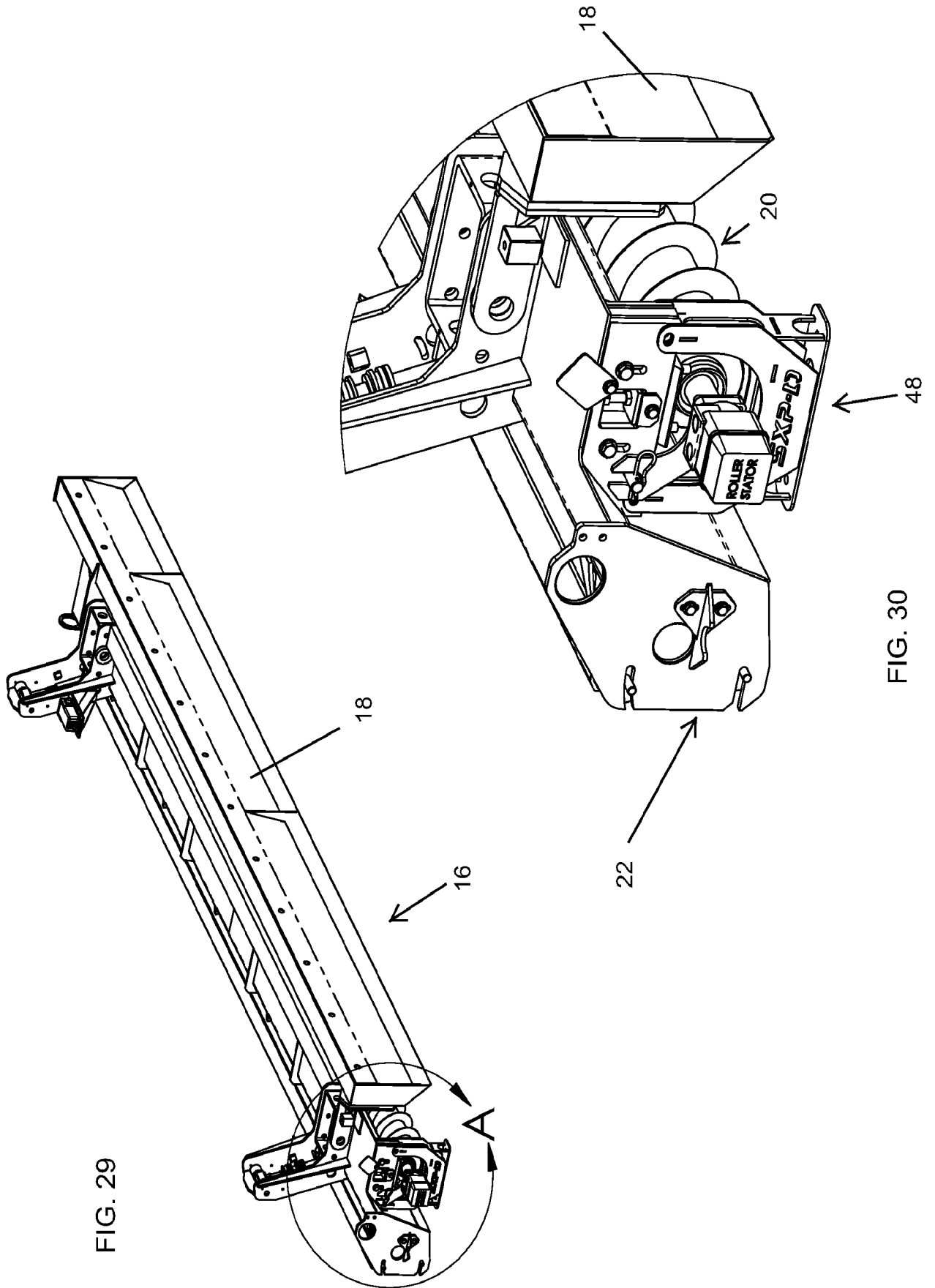

FIG. 29

FIG. 30

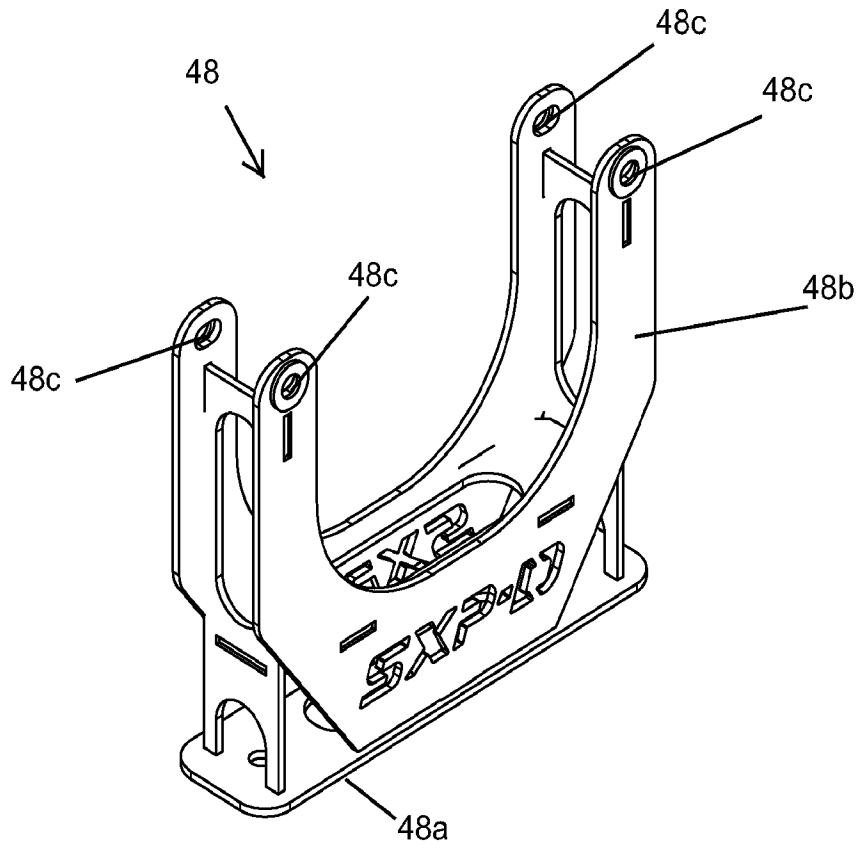

FIG. 31

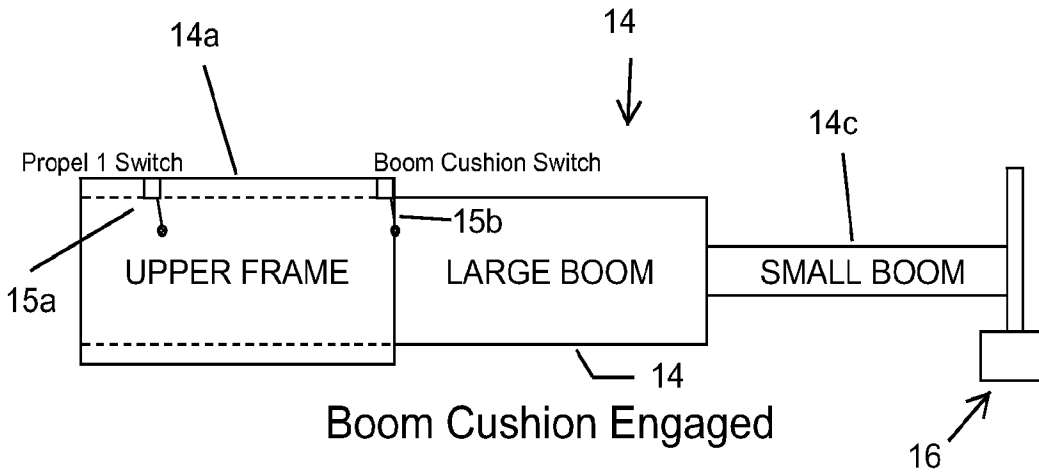

FIG. 32C

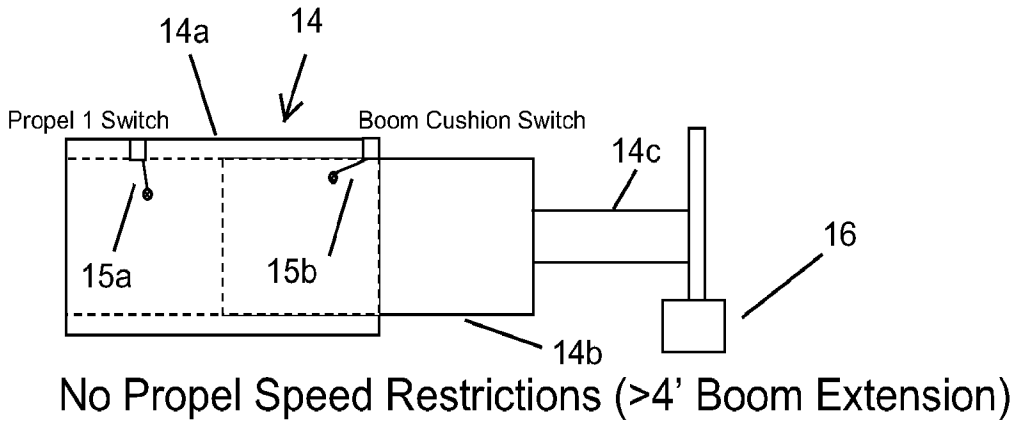

FIG. 32B

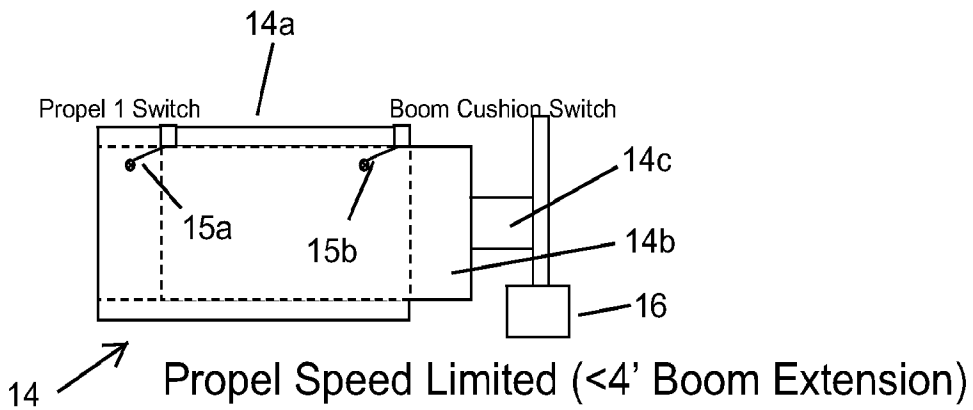

FIG. 32A

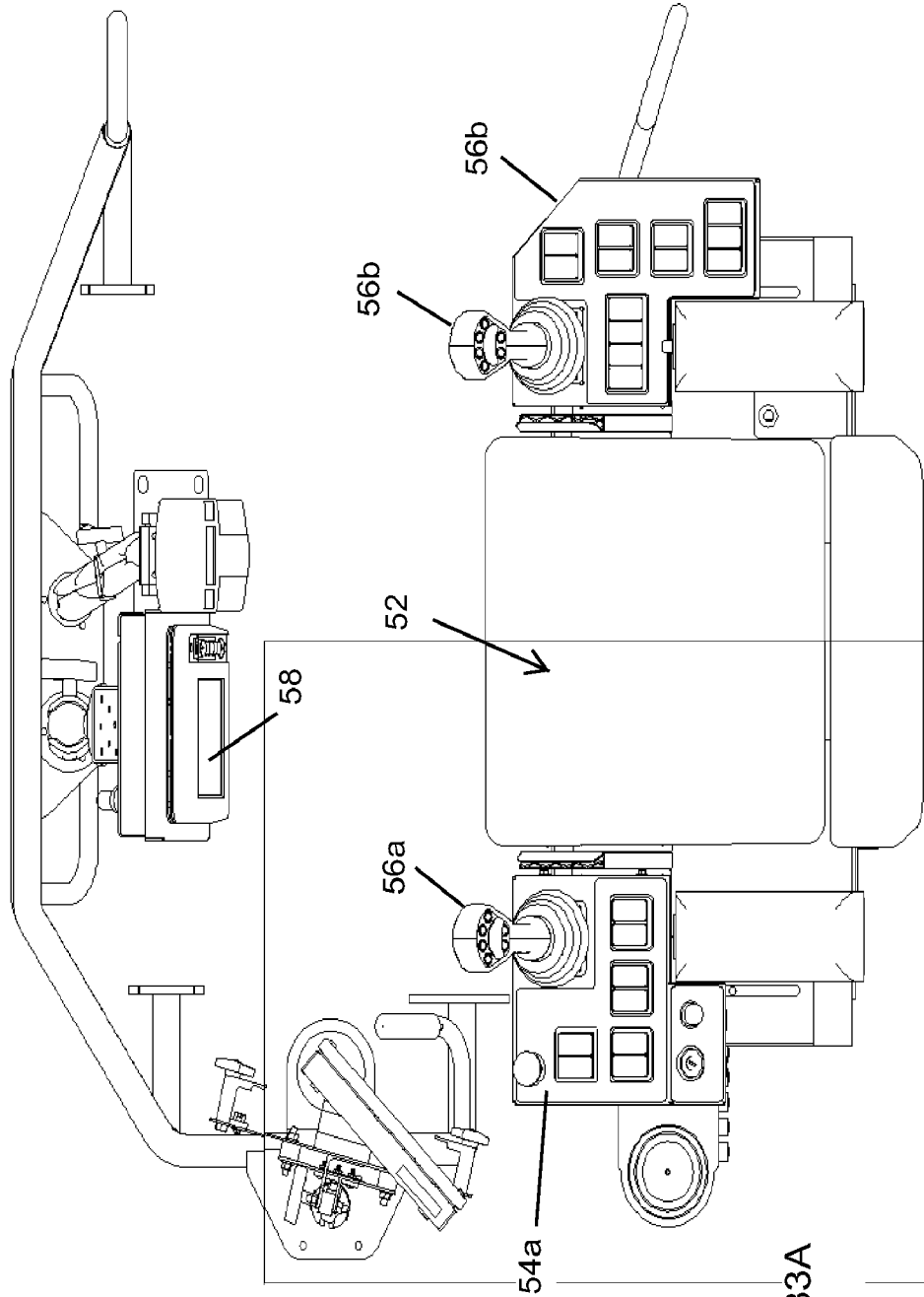
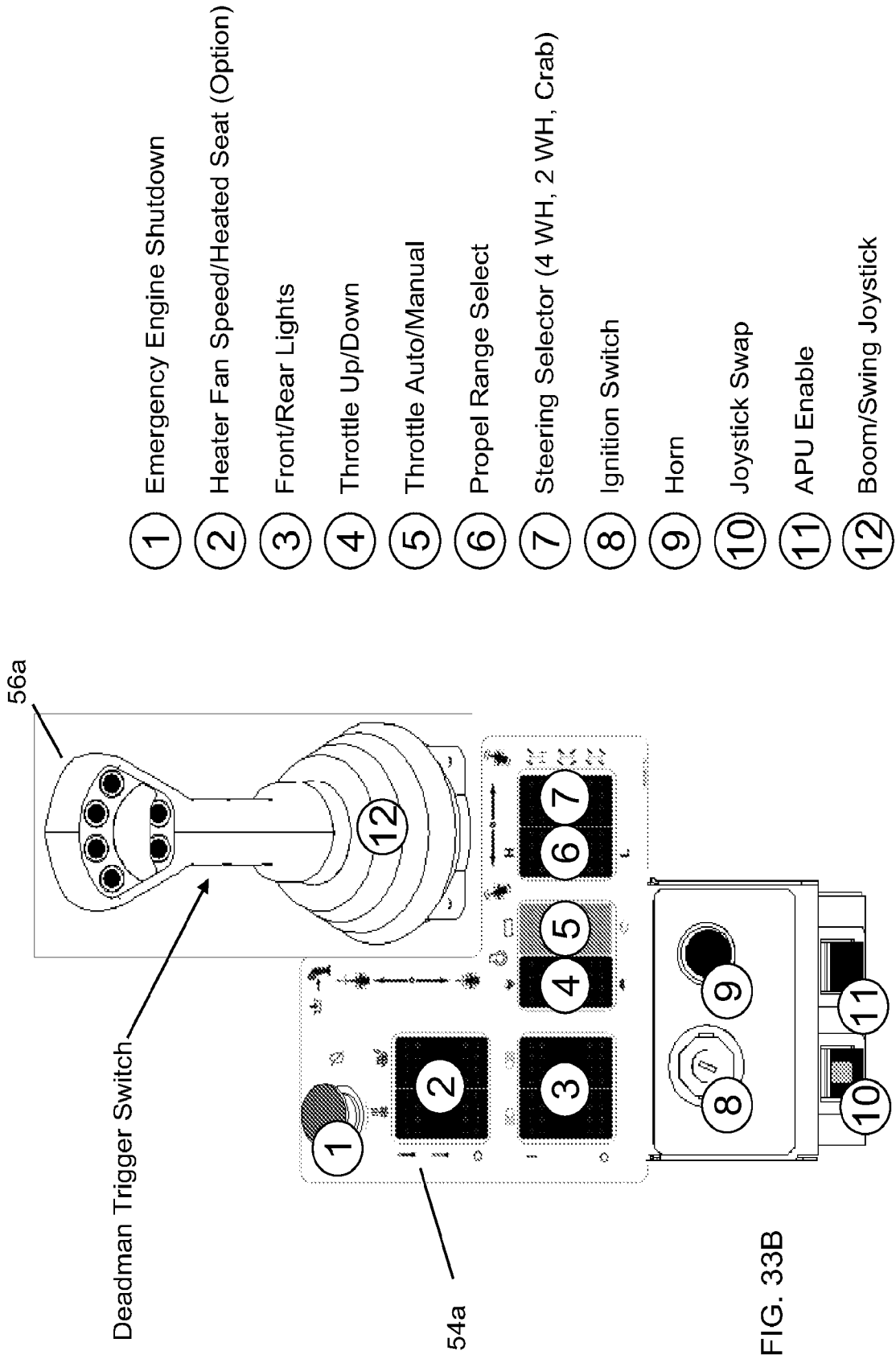
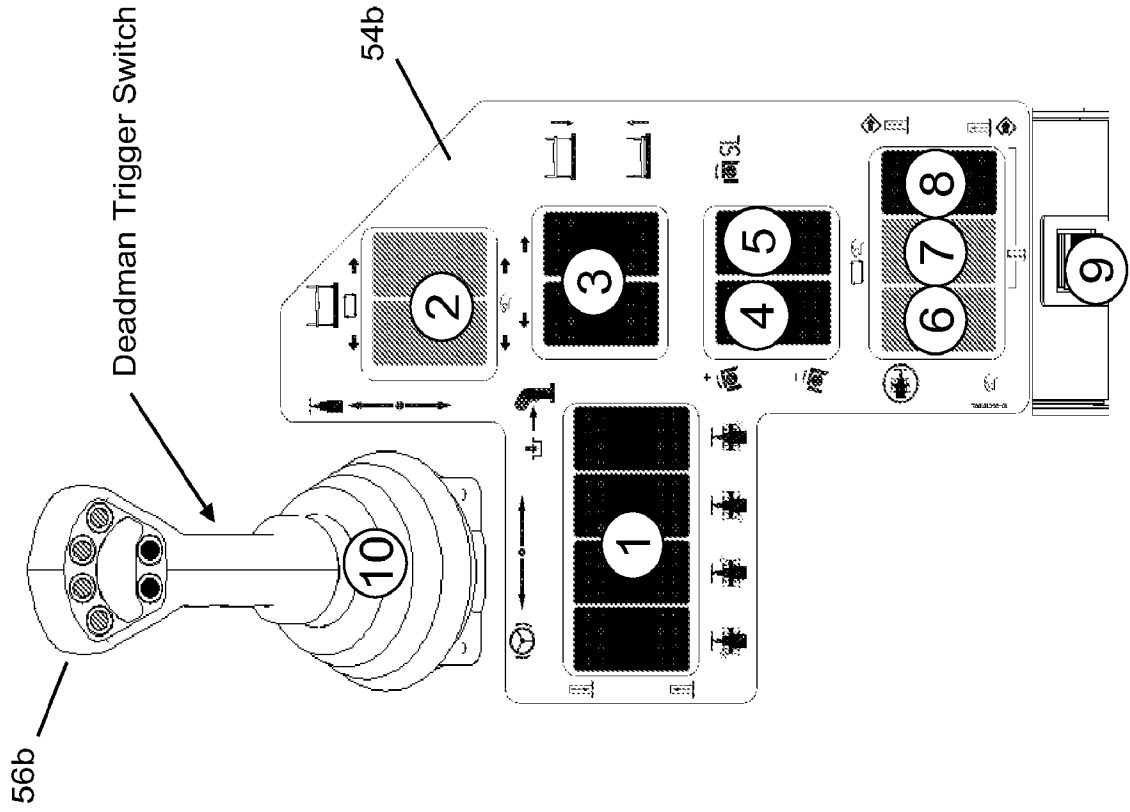

FIG. 33A





- ① Individual Stabilizer
- ② GCS Left/Right Auto/Manual
- ③ Left/Right Elevation Override
- ④ SLS (Self Level System)
- ⑤ Soft Landing
- ⑥ Preset/Manual Mode
- ⑦ Auto-Stabilizers (On/Off)
- ⑧ Auto-Stabilizers (Store Settings)
- ⑨ Oil Warm Up
- ⑩ Propel/Steer Joystick

FIG. 33C

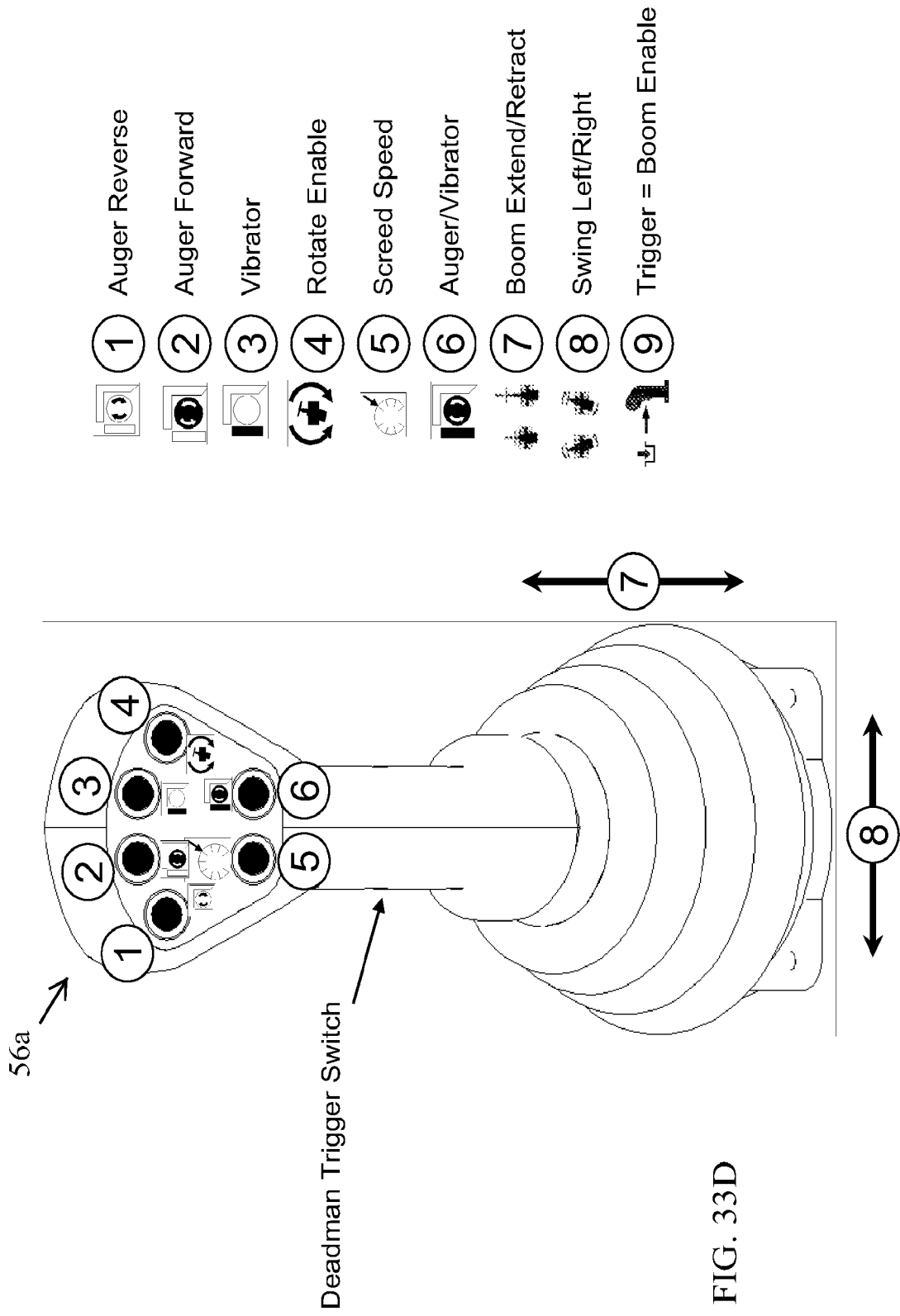

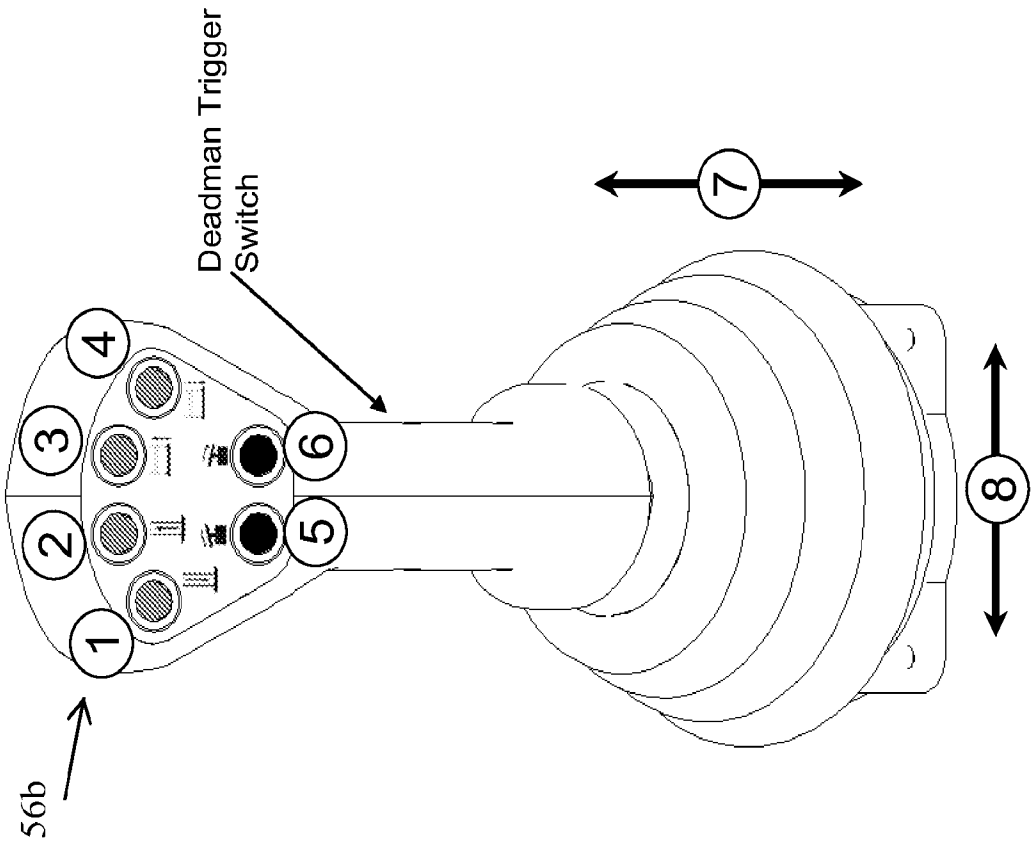

- ① Stabs Extend
- ② Stabs Retract
- ③ Timed Raise
- ④ Timed Lower
- ⑤ Head Left
- ⑥ Head Right
- ⑦ Propel Forward/Reverse
- ⑧ Steer Left/Right (Friction Axis)
- ⑨ Trigger = Propel/Steer Dead Man

FIG. 33E

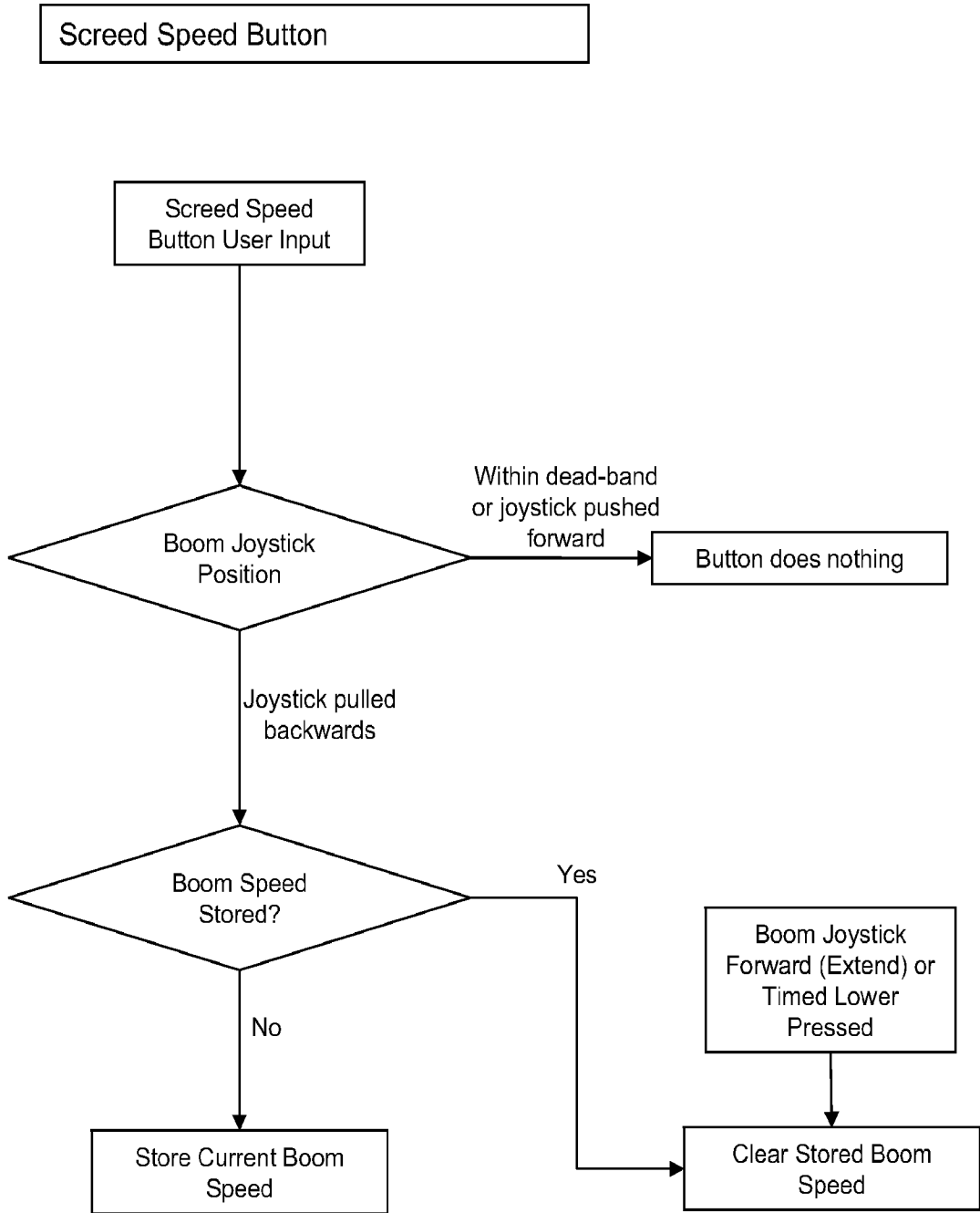
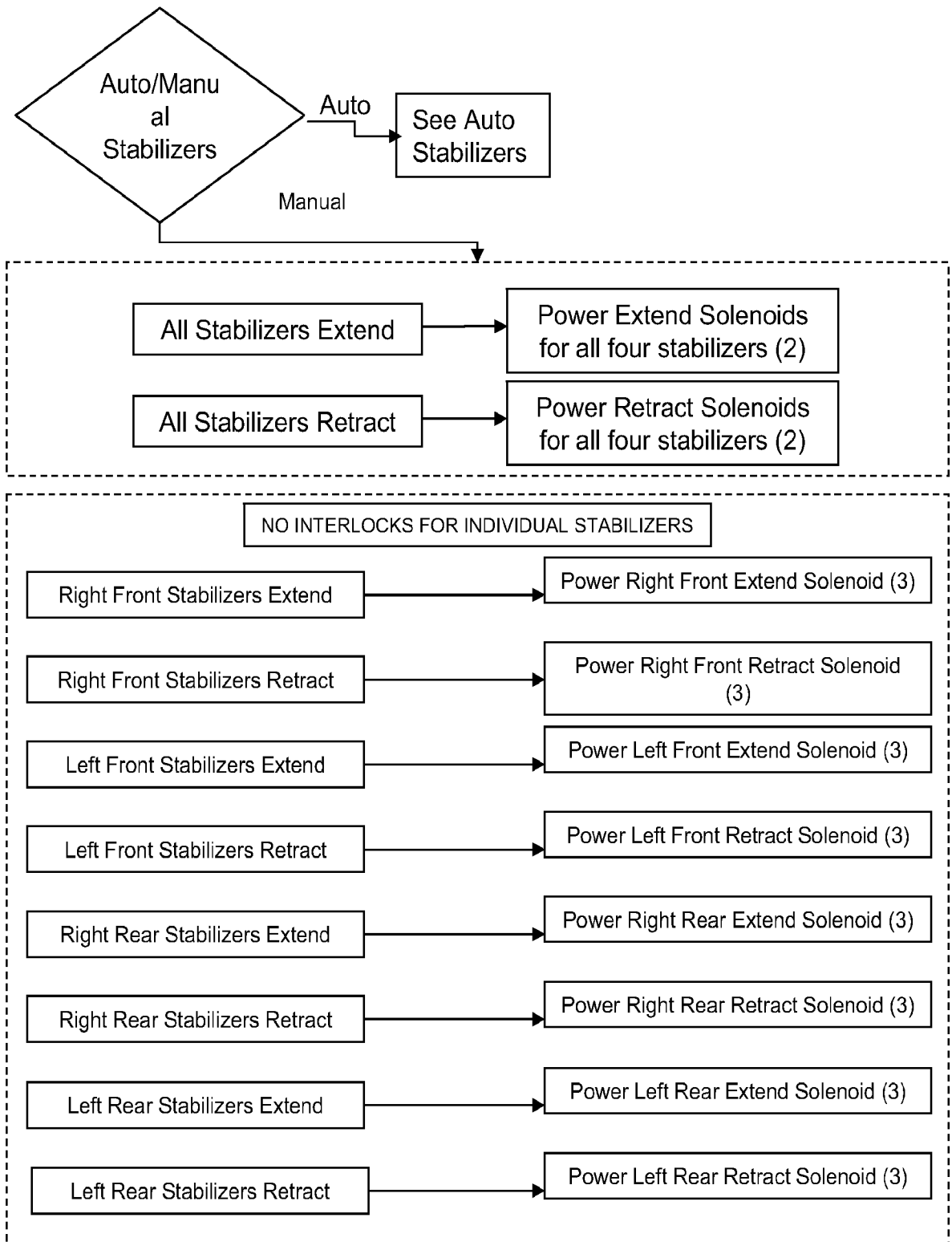

FIG. 34



(2) Speed limited to a percentage of the maximum used for Auto Stabs.

(3) Speed limited to a percentage of the maximum used for Auto Stabs. Different from All Stabs.

FIG. 35A

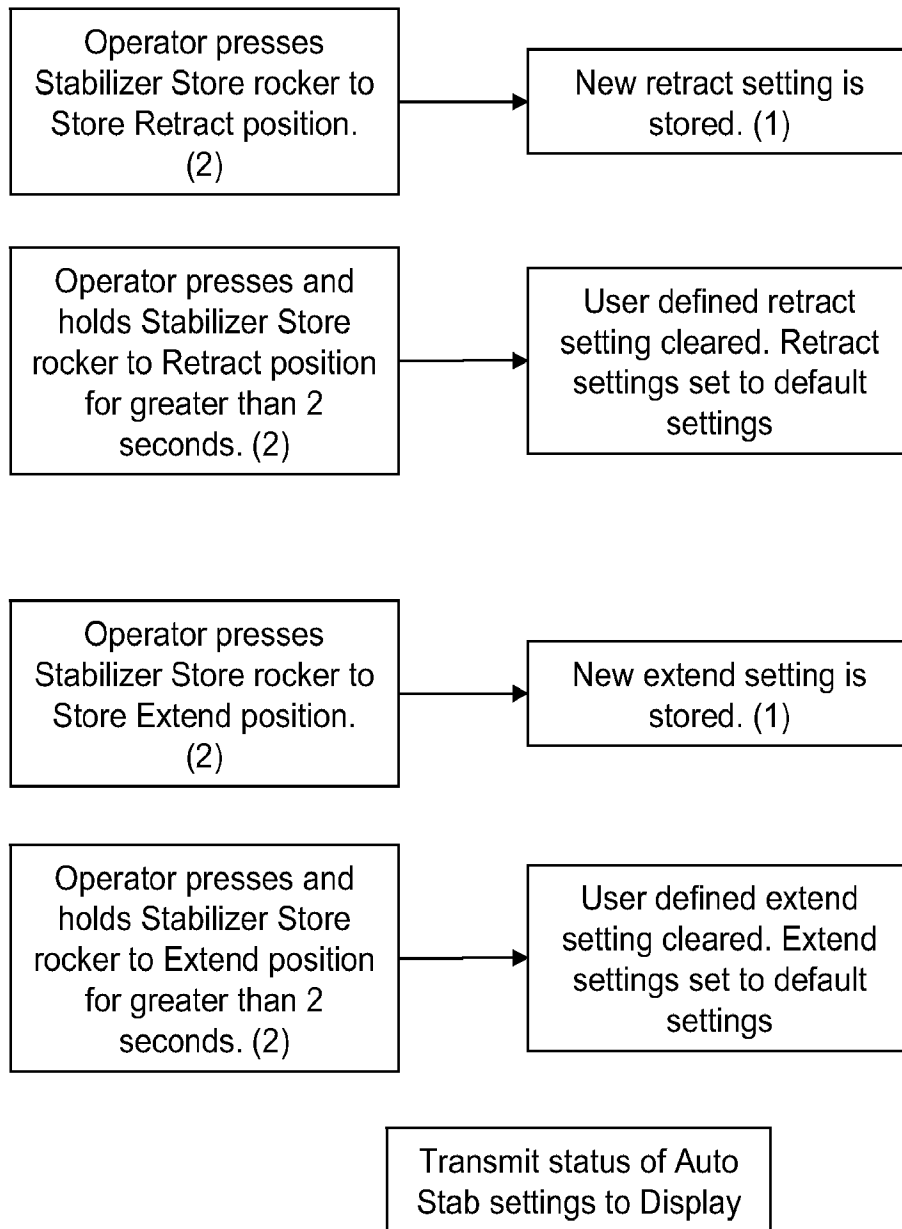

NOTES:

- (1) Saving "Extend/Retract Setting" will temporarily overwrite the previously stored setting. These settings will be stored in memory whether the ECU is powered down or not, until they are cleared by the operator.
- (2) The machine can be in Auto or Manual Stabilizer mode.
- (3) One position sensor on each stabilizer will monitor cylinder position.

FIG. 35B

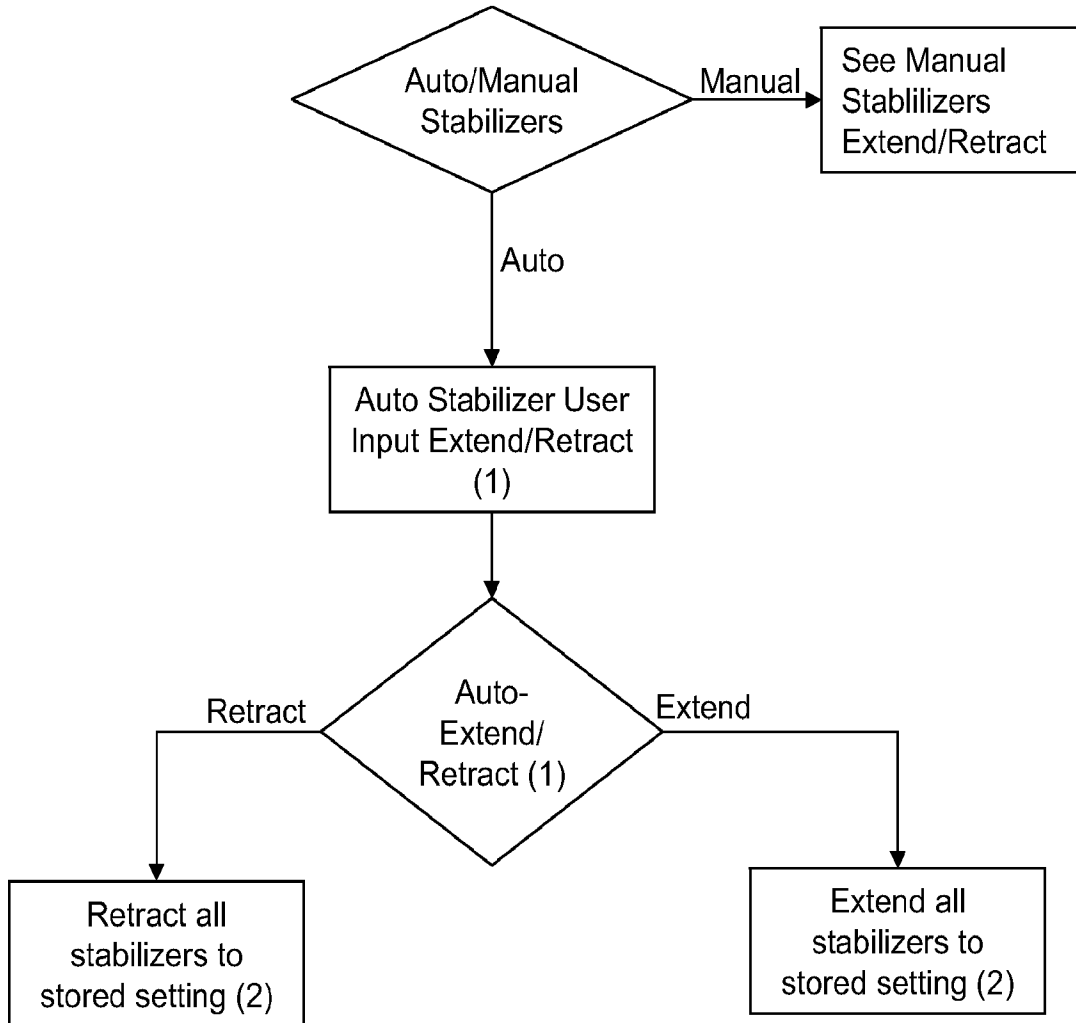

NOTES:

(1) Operator input immediately drives stabilizers. If the button is held for greater than one second then the stabilizers will drive automatically unless the button is pressed again or retract is momentarily pressed.

(2) The operator can overwrite the extend or retract settings by following the Auto-Stabilizers Setup procedure.

FIG. 35C

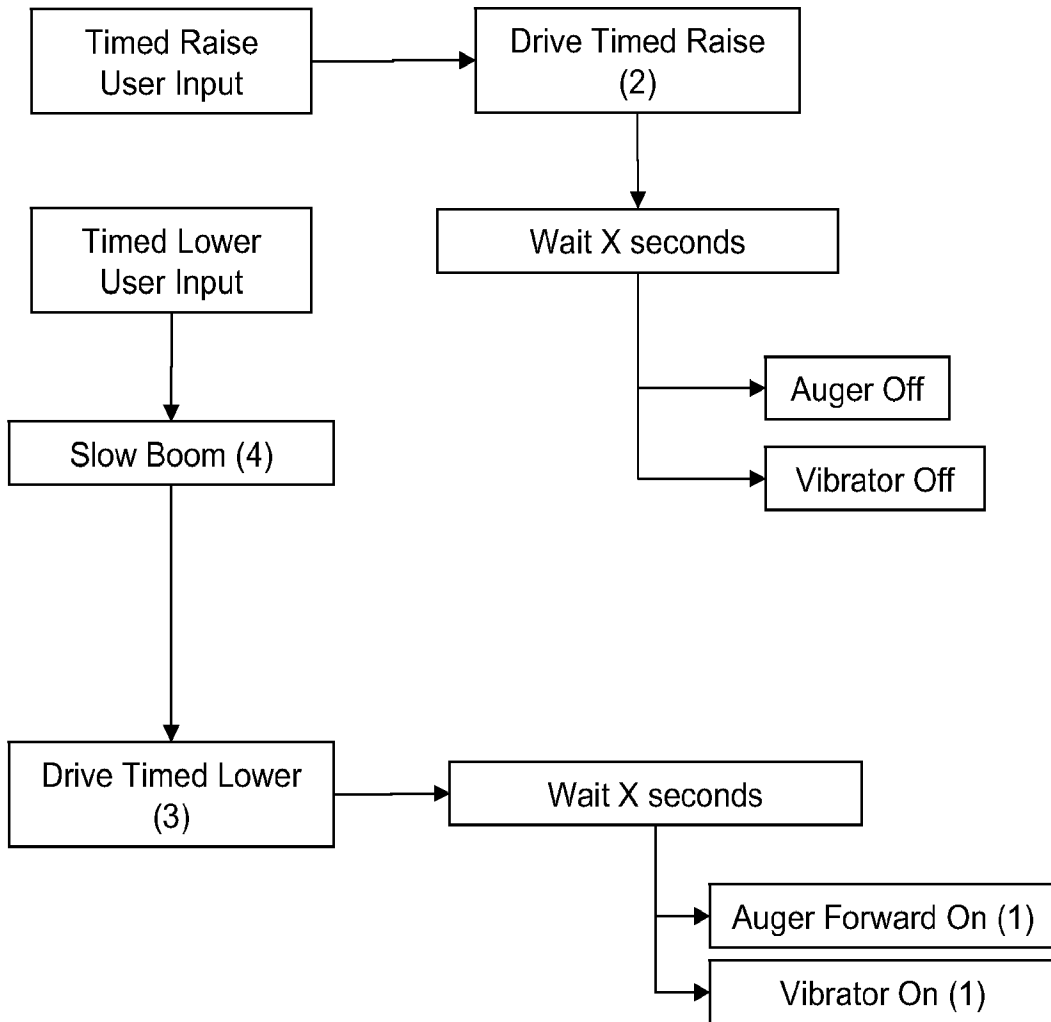

NOTES:

- (1) The display setup screen will allow the user to select auger auto-on or off and vibrator auto-on or off.
- (2) Send "Timed Raise" command to GCS (CAN Message and Timed Raise Driver)
- (3) Send "Timed Lower" command to GCS (CAN Message and Timed Raise Driver)
- (4) Parameter is available that will slow down the boom speed if Timed Lower is pressed.

FIG. 36

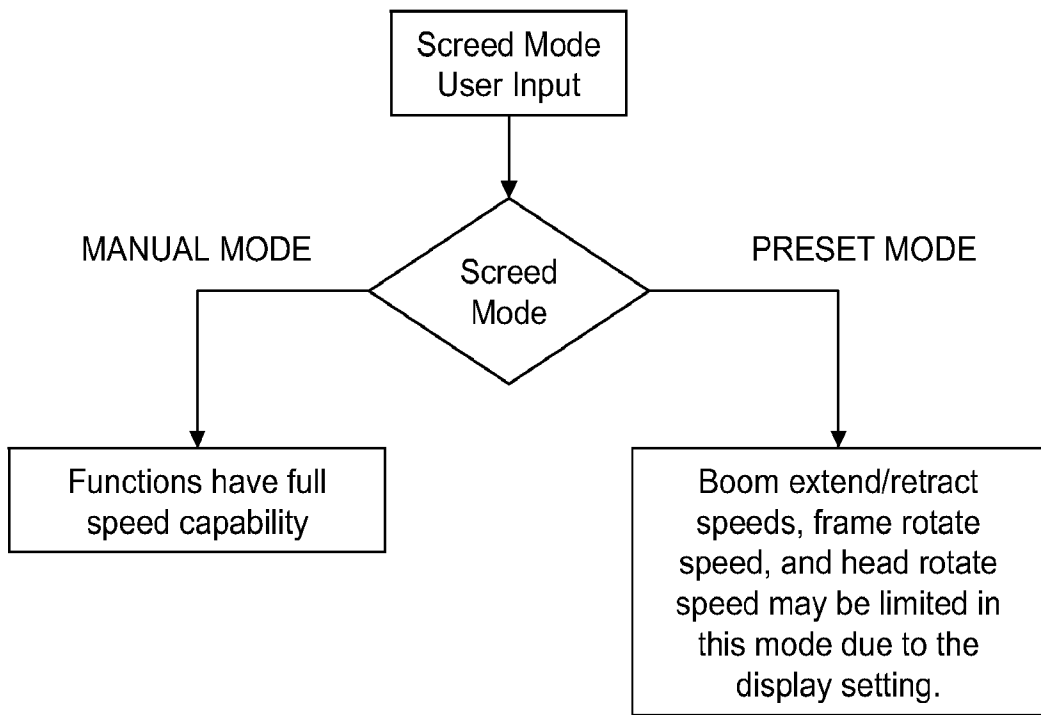

FIG. 37

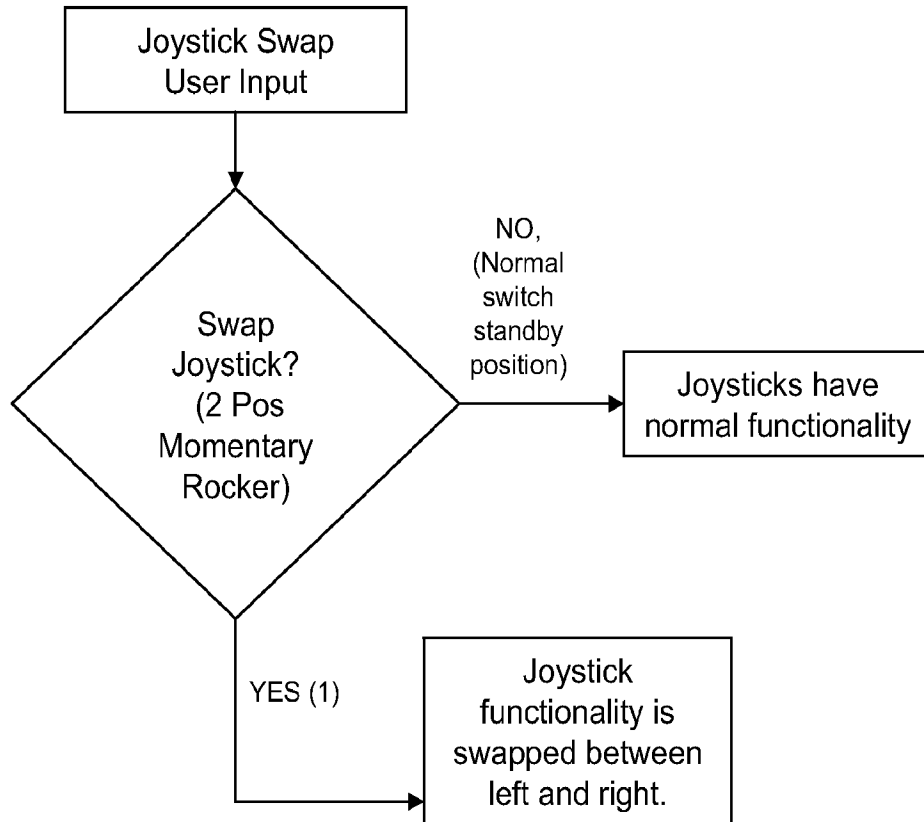

FIG. 38