

(21) Application No: 1522672.3
 (22) Date of Filing: 22.12.2015

(51) INT CL:
 G01L 5/00 (2006.01) A61B 5/03 (2006.01)
 A61B 5/053 (2006.01)

(71) Applicant(s):
The University of Sheffield
(Incorporated in the United Kingdom)
Western Bank, Sheffield S10 2TN, United Kingdom

(56) Documents Cited:
 EP 1750135 A1 WO 2004/098389 A2
 US 20090005707 A1

(72) Inventor(s):
Dilichukwu Anumba
Timothy James Healey

(58) Field of Search:
 INT CL A61B, G01L
 Other: WPI, EPODOC, TXTE

(74) Agent and/or Address for Service:
HGF Limited
Document Handling - HGF - (Sheffield), 1 City Walk,
LEEDS, LS11 9DX, United Kingdom

(54) Title of the Invention: **Apparatus and methods for determining force applied to the tip of a probe**
 Abstract Title: **Measuring the contact force of an EIS probe from its handle to determine the likelihood of preterm birth**

(57) Determining a force applied to a probe tip comprises: an elongate probe 1 with probe tip 2 attached to handle 3, the probe tip having a planar distal end 5 for contacting tissue; a load cell 6 located in the handle, measuring a force applied axially along a longitudinal axis when the tip contacts the tissue; an accelerometer 7 located in the handle to measure a gravity vector; processing means for compensating for the mass of the probe tip, using the measured force and gravity vector to produce calibrated measurement of the force applied to the tip; and display means for indicating to a user the calibrated measurement. In a further aspect raw load cell and accelerometer outputs, the mass of the probe tip and the area of the distal end of the probe tip are obtained and the distal end of the tip is applied to the tissue. The probe may be an electrical impedance spectroscopy probe, determining the electrical conductivity of the tissue, e.g. cervical tissue. The load cell may comprise four strain gauges in a bridge configuration. The display means may include threshold indicators indicating whether too much or too little force is being applied.

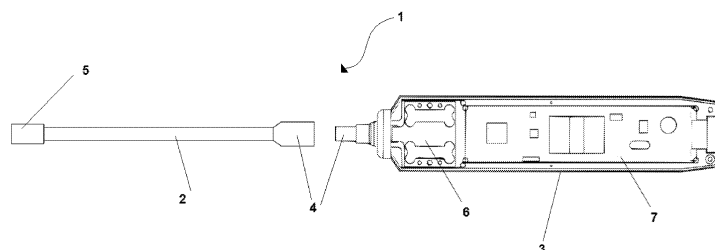

FIGURE 1

1/1

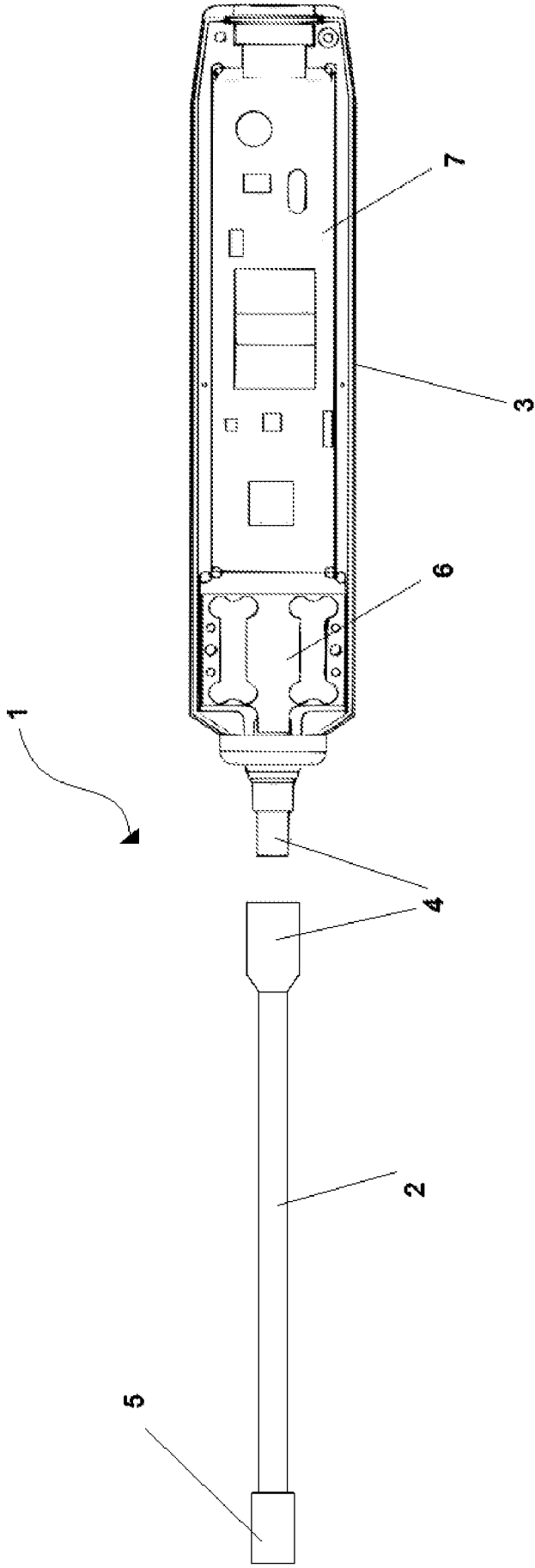

FIGURE 1

APPARATUS AND METHODS FOR DETERMINING FORCE APPLIED TO THE TIP OF A PROBE

TECHNICAL FIELD

5 The present disclosure relates to the field of apparatus and methods for determining the force applied to the tip of a probe, for example an electrical impedance spectroscopy probe. The claimed apparatus and methods can improve the measurement of electrical conductivity of human or animal tissue particularly, but not exclusively, cervical tissue for determining the likelihood of preterm birth.

10

BACKGROUND

Premature delivery is the cause of perinatal death of two-thirds of babies that have no structural abnormalities. It poses a huge economic burden on scarce health resources as each very premature baby born costs several tens of thousands of pounds in neonatal care. When born before 28 weeks gestation, 1 in 4 babies develop disability. These disabilities can cost hundreds of thousands of pounds annually to treat. The families also suffer huge psychosocial burdens, one parent often having to give up work to care for a disabled child. Whilst survival of premature babies is improving, the rate of premature delivery is increasing, currently running at 7-12% of all births. There is no reliable means of identifying women who deliver prematurely. Current methods for identifying women at high risk of delivering prematurely such as ultrasound of the cervix and fetal fibronectin determination have limited accuracy in women who have no history of preterm birth. A technique for reliably predicting preterm birth by universal screening is therefore highly desirable.

25

Electrical impedance spectroscopy (EIS) is a known technique that can be used for assessing cervical pre-cancer as set out in, for example, WO2006/12910 (Brown and Tidy) and WO 2006/129116(Brown and Tidy). Other publications concerning EIS for cervical investigations include:

30

Avis(1996). In vitro multifrequency electrical impedance measurements and modelling of the cervix in late pregnancy. *Physiol Meas* 17Suppl 4A:A97
Brown(2000). Relation between tissue structure and imposed electrical current flow in cervical neoplasia. *Lancet* 355(9207):892

Gandhi(2006). Comparison of human uterine cervical electrical impedance measurements derived using two tetrapolar probes. Biomed Eng Online 5:62

Gandhi(2006). Electrical impedance spectroscopy of the cervix in non-pregnant and pregnant women. Eur J Obstet Gynecol ReprodBiol 129:145

5 Hoe et al (2004) Measuring Bioimpedance in the Human Uterine Cervix: Towards Early Detection of Preterm Labor. Proceedings of the 26th Annual Conference of the IEEE EMBS San Francisco, CA, USA. Sept 1-5 2004.

Jokhi(2009). Reproducibility and repeatability of measuring the electrical impedance of the pregnant human cervix. Biomed Eng Online 8:10; and

10 Jokhi(2009). The role of cervical Electrical Impedance Spectroscopy in the prediction of the course and outcome of induced labour. BMC Pregnancy Childbirth 9:40

The applicant has investigated the value of using EIS to measure the “resistance” of the cervix to very small electrical currents (in other words, the electrical conductivity or bioimpedance of the cervical tissue) to detect changes that may precede premature birth. A serial pilot study of women at high risk of preterm birth showed predictive accuracy for premature delivery before 37 and 34 weeks. However significant measurement error was observed using the EIS technique and it is desired to improve accuracy and repeatability of the measurements. One possible reason for measurement error in the EIS technique is that it is difficult to ensure consistent pressure on the cervical tissue by the EIS probe. The Hoe et al paper mentioned above tackles this problem by using a constant force spring to enable more consistent measurements through a range of applied contact forces. The mucus layer on the cervix affects tissue electrical conductivity, adding further error.

25

It is an aim of the present invention to address disadvantages associated with the known prior art.

BRIEF SUMMARY OF THE DISCLOSURE

30

Aspects and embodiments of the invention provide apparatus and methods as claimed in the appended claims.

According to an aspect of the invention there is provided apparatus capable of determining the force applied to the tip of a probe, for example an electrical impedance spectroscopy probe, comprising:

35

an elongate probe comprising a probe tip attached to a handle, the probe tip having a substantially planar distal end for contacting human or animal tissue;

a load cell located in said handle and capable of measuring a force F_{loadcell} applied axially along a longitudinal axis when said probe tip is in contact with said human or animal tissue;

an accelerometer located in the handle for measuring a gravity vector A_{axial} ;

processing means for compensating for the mass of the probe tip using said measured force and gravity vector to produce a calibrated measurement of force F applied to said probe tip;

display means for indicating to a user the calibrated measurement of force.

In an embodiment, the processing means is further capable of determining an electrical conductivity of human or animal tissue to which the distal end of the probe tip is applied. Preferably, the human or animal tissue is cervical tissue.

15

In an embodiment, said load cell comprises four strain gauges in a bridge configuration.

In an embodiment, said accelerometer is an analogue tri-axial MEMS accelerometer.

Said processing means may include analogue to digital converters to digitise the outputs of said load cell and said accelerometer.

20

In an embodiment, said calibrated measurement of force $F = F_{\text{loadcell}} - A_{\text{axial}} * (M_{\text{tip}} + M_{\text{load}})$, where A_{axial} is the output of the accelerometer aligned in the axial direction of the probe tip, M_{tip} is the mass of the probe tip and M_{load} is the free mass of the load cell and other parts connected to the load cell such as the connector for the probe tip.

25

Preferably, said display means is capable of indicating real-time calibrated measurements of force applied to the probe tip.

30

In an embodiment, said display means includes threshold indications indicating whether too much or too little force is being applied to the probe tip.

The apparatus may further include recording means for recording measurements to facilitate a repeatable application of force to the probe tip.

35

According to another aspect of the invention there is provided a method of determining the force applied to the tip of a probe, for example an electrical impedance spectroscopy probe, using apparatus as claimed in any of the preceding claims, the method including the steps of:

- 5 obtaining a raw load cell output;
 obtaining a raw accelerometer output;
 obtaining the mass of the probe tip;
 obtaining the area of the distal end of the probe tip;
 applying the distal end of the probe tip to human or animal tissue and measuring
10 a force F_{loadcell} applied axially along a longitudinal axis when said probe tip is in contact
with said human or animal tissue;
 using said accelerometer to measure a gravity vector A_{axial} ;
 using said processing means to compensate for the mass of the probe tip using
said measured force and gravity vector to produce a calibrated measurement of force F
15 applied to said probe tip;
 using said display means to indicate to a user the calibrated measurement of
force.

Further features are defined in the appended claims.

20

Within the scope of this application it is expressly intended that the various aspects, embodiments, examples and alternatives set out in the preceding paragraphs, in the claims and/or in the following description and drawings, and in particular the individual features thereof, may be taken independently or in any combination. That is, all
25 embodiments and/or features of any embodiment can be combined in any way and/or combination, unless such features are incompatible. The applicant reserves the right to change any originally filed claim or file any new claim accordingly, including the right to amend an originally filed claim to depend from and/or incorporate any feature of any other claim although not originally claimed in that manner.

30

Throughout the description and claims of this specification, the words “comprise” and “contain” and variations of the words, for example “comprising” and “comprises”, means “including but not limited to”, and is not intended to (and does not) exclude other moieties, additives, components, integers or steps.

35

Throughout the description and claims of this specification, the singular encompasses the plural unless the context otherwise requires. In particular, where the indefinite article is used, the specification is to be understood as contemplating plurality as well as singularity, unless the context requires otherwise.

5

BRIEF DESCRIPTION OF THE DRAWINGS

One or more embodiments of the invention will now be described, by way of example only, with reference to the accompanying drawing in which:

10 Figure 1 is a schematic representation of an elongate probe for use in an embodiment of the invention.

DETAILED DESCRIPTION

15 Figure 1 shows an elongate probe 1 which has a handle 3 attached to a probe tip 2. The probe tip can be attached to the handle using a standard commercial connector arrangement 4. The probe tip 2 may be removeably attached to the handle 3 so that the clinician can select and interchange different probe tips for different patients. The probe tip 2 has a substantially planar distal end 5 which includes an arrangement of
20 electrodes, for example a tetrapole arrangement of known type for use in electrical impedance spectroscopy.

A load cell 6 is located in the handle 3. A triaxial MEMS accelerometer 7 is also provided in the handle 3 of the probe 1 and, hence, is in a fixed relationship to both the
25 probe tip 2 and the load cell 6.

The EIS technique involves placing the distal end 5 of the probe tip 2 against the tissue whose electrical conductivity it is desired to measure. The pressure applied by the clinician as the probe tip is placed on the tissue is important as differences in applied
30 pressure significantly affect the results. The changes in cervical tissue measured as an indicator of pre-term birth are more subtle and hence more prone to being affected by the applied pressure than the pre-cancerous changes which are more usually measured by the EIS technique. Consequently it is not only important to be able to repeat the same applied pressure when taking sequential measurements but it is also important to
35 apply pressure within predetermined thresholds.

The apparatus described herein facilitates this by providing the clinician or other user with a display means indicating the applied pressure and indicating whether that applied pressure is within a desired range. This could be done by a bar graph or a traffic light indicator, for example, with a green light displayed when the applied pressure is within a
5 desired range. Alternatively or in addition, an audible alarm or other signal may be provided.

The apparatus described herein is able to compensate for the mass of the probe tip 2 in order to measure (and display) a calibrated measurement of the applied force which is
10 more accurate than a direct measurement of the force applied at the probe tip. The probe tip 2 has a known mass which, due to the action of gravity, could apply a force (dependent on the orientation of the probe) that significantly affects the accuracy of the direct measurement.

15 It is only necessary to measure the applied force at the probe tip 2 in order to determine the applied pressure because the probe tip has a known area at its distal end 5 (and $P = F/A$).

The load cell 6 measures the force applied axially along the longitudinal axis of the
20 probe tip. This force is equal to the force applied to the probe tip together with the mass of the tip multiplied by gravity and resolved in the axial direction. The mass of the probe tip is known and the local gravity vector with respect to the probe A_{axial} is measured using the accelerometer. It is therefore possible in this way to obtain a calibrated measurement of the force applied to the probe tip which compensates for the
25 mass of the tip.

In the illustrated embodiment, the load cell 6 comprises four foil strain gauges arranged in a bridge configuration. The bridge can be excited by bursts of square wave pulses at a frequency of 1 kHz which allows the detection of the small resistance change of the
30 load cell bridge with both low power requirements and low sensitivity to DC drift. The output of the bridge can be amplified by and filtered with a Sallen and Key circuit, whose output can be sampled many times per cycle by a microcontroller's analogue to digital converter circuit. Other methods of electrically measuring force would be suitable for this application and understood by the skilled reader.

35

In the illustrated embodiment, the accelerometer 7 is an "Analog Devices" tri-axial MEMS device whose output is suitable for direct connection to the microcontroller's analogue to digital converter circuit. The only signal processing required is simple linear calibration for zero and range. The calibrated tri-axial output of the accelerometer 7 is operated on by a rotation matrix so that it can be accurately aligned with the longitudinal axis of the probe 1. Other methods of measuring the gravity vector resolved to the longitudinal axis of the probe would be suitable for this application and understood by the skilled reader.

10 The mass of the probe tip can be measured with a balance and stored in an EEPROM within the probe tip 2. Probe tips 2 can be easily interchangeable because the probe 1 can read the mass for each specific probe tip 2 from its EEPROM. The free mass of the load cell 6 can be found by a calibration process wherein the probe 1 is held in two orientations . It is possible to do a full automatic load cell calibration using the known
15 mass of the probe tip 2 and the output of the accelerometer 7, by asking the user to hold the probe 1 in different positions.

A display means (not illustrated) gives the clinician feedback as to whether the force applied to the probe tip 2 is within acceptable limits. The display means could be a five
20 LED bar graph wherein the central LED is highlighted to indicate the desired pressure and progressively more LEDs are lit as the pressure is increased. The range of pressure thresholds required to light each of the LEDs are programmable.

The probe 1 can be set only to take EIS measurements when the pressure is within
25 acceptable limits. An LED bar graph is intuitive to use and, under test, allowed the handheld probe 1 to maintain EIS measurements within the limits of +/- 6% of the desired force.

The processing means are provided, for example in the form of a PC which can record
30 patient information, guide the clinician through the measuring process, control the probe, analyse and save the results in a database.

Although the description above is in relation to an EIS probe, the apparatus and force measurement technique described herein can be used in other applications. For
35 example, the apparatus could be used to determine the force applied to the tip of a

probe used in joint surgery to assess the quality of fit of a new joint. Other applications can be envisaged.

CLAIMS

1. Apparatus capable of determining the force applied to the tip of a probe, for example an electrical impedance spectroscopy probe, comprising:
 - 5 an elongate probe comprising a probe tip attached to a handle, the probe tip having a substantially planar distal end for contacting human or animal tissue;
 - a load cell located in said handle and capable of measuring a force F_{loadcell} applied axially along a longitudinal axis when said probe tip is in contact with said human or animal tissue;
 - 10 an accelerometer located in the handle for measuring a gravity vector A_{axial} ;
 - processing means for compensating for the mass of the probe tip using said measured force and gravity vector to produce a calibrated measurement of force F applied to said probe tip;
 - display means for indicating to a user the calibrated measurement of force.
 - 15
2. Apparatus as claimed in claim 1 wherein the processing means is further capable of determining an electrical conductivity of human or animal tissue to which the distal end of the probe tip is applied.
- 20 3. Apparatus as claimed in claim 2 wherein the human or animal tissue is cervical tissue.
4. Apparatus as claimed in any of the preceding claims wherein said load cell comprises four strain gauges in a bridge configuration.
- 25 5. Apparatus as claimed in any of the preceding claims wherein said accelerometer is an analogue tri-axial MEMS accelerometer.
6. Apparatus as claimed in any of the preceding claims wherein said processing means includes analogue to digital converters to digitise the outputs of said load cell and said accelerometer.
- 30 7. Apparatus as claimed in any of the preceding claims wherein said calibrated measurement of force $F = F_{\text{loadcell}} - A_{\text{axial}} * (M_{\text{tip}} + M_{\text{load}})$, where A_{axial} is the output of the accelerometer aligned in the axial direction of the probe tip, M_{tip} is the mass of the
- 35

probe tip and M_{load} is the free mass of the load cell and other parts connected to the load cell such as the connector for the probe tip.

8. Apparatus as claimed in any of the preceding claims wherein said display means
5 is capable of indicating real-time calibrated measurements of force applied to the probe tip.

9. Apparatus as claimed in any of the preceding claims wherein said display means
10 includes threshold indications indicating whether too much or too little force is being applied to the probe tip.

10. Apparatus as claimed in any of the preceding claims further including recording
means for recording measurements to facilitate a repeatable application of force to the
15 probe tip.

11. Apparatus capable of determining the force applied to the tip of a probe, for
example an electrical impedance spectroscopy probe, substantially as described herein
with reference to and as illustrated in any appropriate combination of the accompanying
20 drawings.

12. Method of determining the force applied to the tip of a probe, for example an
electrical impedance spectroscopy probe, using apparatus as claimed in any of the
preceding claims, the method including the steps of:

25 obtaining a raw load cell output;
obtaining a raw accelerometer output;
obtaining the mass of the probe tip;
obtaining the area of the distal end of the probe tip;
applying the distal end of the probe tip to human or animal tissue and measuring
a force $F_{loadcell}$ applied axially along a longitudinal axis when said probe tip is in contact
30 with said human or animal tissue;

using said accelerometer to measure a gravity vector A_{axial} ;
using said processing means to compensate for the mass of the probe tip using
said measured force and gravity vector to produce a calibrated measurement of force F
applied to said probe tip;

35 using said display means to indicate to a user the calibrated measurement of
force.

13. Method of determining the force applied to the tip of a probe, for example an electrical impedance spectroscopy probe, substantially as described herein with reference to and as illustrated in any appropriate combination of the accompanying
5 drawings.

10

Amendments to the claims have been made as follows

CLAIMS

1. Apparatus capable of determining a force F applied to a tip of a probe the apparatus comprising:
 - an elongate probe comprising said probe tip attached to a handle, the probe tip having a substantially planar distal end for contacting human or animal tissue;
 - a load cell located in said handle and capable of measuring a force F_{loadcell} applied axially to said elongate probe along a longitudinal axis thereof when said probe tip is in contact with said human or animal tissue;
 - an accelerometer located in the handle for measuring a gravity vector A_{axial} ;
 - processing means for compensating for the mass of the probe tip using said measured force and gravity vector to produce a calibrated measurement of said force F applied to said probe tip;
 - display means for indicating to a user the calibrated measurement of said force F .
2. Apparatus as claimed in claim 1 wherein the processing means is further capable of determining an electrical conductivity of human or animal tissue to which the distal end of the probe tip is applied.
3. Apparatus as claimed in claim 2 wherein the human or animal tissue is cervical tissue.
4. Apparatus as claimed in any of the preceding claims wherein said load cell comprises four strain gauges in a bridge configuration.
5. Apparatus as claimed in any of the preceding claims wherein said accelerometer is an analogue tri-axial MEMS accelerometer.
6. Apparatus as claimed in any of the preceding claims wherein said processing means includes analogue to digital converters to digitise the outputs of said load cell and said accelerometer.
7. Apparatus as claimed in any of the preceding claims wherein said calibrated measurement of force $F = F_{\text{loadcell}} - A_{\text{axial}} * (M_{\text{tip}} + M_{\text{load}})$, where A_{axial} is the output of the accelerometer aligned in the axial direction of the probe tip, M_{tip} is the mass of the probe tip and M_{load} is the free mass of the load cell and a connector for the probe tip.

21 12 16

8. Apparatus as claimed in any of the preceding claims wherein said display means is capable of indicating real-time calibrated measurements of force applied to the probe tip.

9. Apparatus as claimed in any of the preceding claims wherein said display means includes threshold indications indicating whether too much or too little force is being applied to the probe tip.

10. Apparatus as claimed in any of the preceding claims further including recording means for recording measurements to facilitate a repeatable application of force to the probe tip.

11. Apparatus as claimed in any of the preceding claims wherein said probe is an electrical impedance spectroscopy probe.

12. Method of determining a force F applied to a tip of a probe using apparatus as claimed in any of the preceding claims, the method including the steps of:

obtaining a raw load cell output;

obtaining a raw accelerometer output;

obtaining the mass of said probe tip;

obtaining the area of the distal end of the probe tip;

applying the distal end of the probe tip to human or animal tissue and measuring a force $F_{loadcell}$ applied axially to said elongate probe along a longitudinal axis thereof when said probe tip is in contact with said human or animal tissue;

using said accelerometer to measure a gravity vector A_{axial} ;

using said processing means to compensate for the mass of the probe tip using said measured force and gravity vector to produce a calibrated measurement of said force F applied to said probe tip;

using said display means to indicate to a user the calibrated measurement of said force F .

13. Method as claimed in claim 12 wherein said probe is an electrical impedance spectroscopy probe.



Application No: GB1522672.3

Examiner: Laura Goacher

Claims searched: 1-13

Date of search: 14 June 2016

Patents Act 1977: Search Report under Section 17

Documents considered to be relevant:

| Category | Relevant to claims | Identity of document and passage or figure of particular relevance |
|----------|--------------------|--|
| A | - | US2009/005707 A1 (SARVAZYAN et al) See paragraphs [0025] and [0026] |
| A | - | EP1750135 A1 (ROHDE & SCHWARZ) See EPODOC abstract |
| A | - | WO2004/098389 A2 (JOHNS HOPKINS UNIVERSITY) See EPODOC abstract |

Categories:

| | | | |
|---|---|---|--|
| X | Document indicating lack of novelty or inventive step | A | Document indicating technological background and/or state of the art. |
| Y | Document indicating lack of inventive step if combined with one or more other documents of same category. | P | Document published on or after the declared priority date but before the filing date of this invention. |
| & | Member of the same patent family | E | Patent document published on or after, but with priority date earlier than, the filing date of this application. |

Field of Search:

Search of GB, EP, WO & US patent documents classified in the following areas of the UKC^X :

| |
|--|
| |
|--|

Worldwide search of patent documents classified in the following areas of the IPC

A61B; G01L

The following online and other databases have been used in the preparation of this search report

WPI, EPODOC, TXTE

International Classification:

| Subclass | Subgroup | Valid From |
|----------|----------|------------|
| G01L | 0005/00 | 01/01/2006 |
| A61B | 0005/03 | 01/01/2006 |
| A61B | 0005/053 | 01/01/2006 |