

(19) World Intellectual Property
Organization
International Bureau



(43) International Publication Date
7 October 2004 (07.10.2004)

PCT

(10) International Publication Number
WO 2004/085732 A1

- (51) International Patent Classification⁷: **D06F 75/10**,
75/22 (NL). **CHING, Boon, Khian** [MY/SG]; c/o Prof. Holst-
laan 6, NL-5656 AA Eindhoven (NL).
- (21) International Application Number:
PCT/IB2004/050296 (74) **Agent: BOS, Kornelis, S.**; Prof. Holstlaan 6, NL-5656
AA Eindhoven (NL).
- (22) International Filing Date: 22 March 2004 (22.03.2004) (81) **Designated States** (unless otherwise indicated, for every
kind of national protection available): AE, AG, AL, AM,
AT, AU, AZ, BA, BB, BG, BR, BW, BY, BZ, CA, CH, CN,
CO, CR, CU, CZ, DE, DK, DM, DZ, EC, EE, EG, ES, FI,
GB, GD, GE, GH, GM, HR, HU, ID, IL, IN, IS, JP, KE,
KG, KP, KR, KZ, LC, LK, LR, LS, LT, LU, LV, MA, MD,
MG, MK, MN, MW, MX, MZ, NA, NI, NO, NZ, OM, PG,
PH, PL, PT, RO, RU, SC, SD, SE, SG, SK, SL, SY, TJ, TM,
TN, TR, TT, TZ, UA, UG, US, UZ, VC, VN, YU, ZA, ZM,
ZW.
- (25) Filing Language: English
- (26) Publication Language: English
- (30) Priority Data:
PCT/SG03/00084 25 March 2003 (25.03.2003) SG
- (71) Applicant (for all designated States except US): **KONIN-
KLIJKE PHILIPS ELECTRONICS N.V.** [NL/NL];
Groenewoudseweg 1, NL-5621 BA Eindhoven (NL).
- (72) Inventors; and
- (75) Inventors/Applicants (for US only): **JIANG, Yong**
[SG/SG]; c/o Prof. Holstlaan 6, NL-5656 AA Eindhoven
(NL). **VALIYAMBATH KRISHNAN, Mohankumar**
[IN/SG]; c/o Prof. Holstlaan 6, NL-5656 AA Eindhoven
- (84) **Designated States** (unless otherwise indicated, for every
kind of regional protection available): ARIPO (BW, GH,
GM, KE, LS, MW, MZ, SD, SL, SZ, TZ, UG, ZM, ZW),
Eurasian (AM, AZ, BY, KG, KZ, MD, RU, TJ, TM), Euro-
pean (AT, BE, BG, CH, CY, CZ, DE, DK, EE, ES, FI, FR,
GB, GR, HU, IE, IT, LU, MC, NL, PL, PT, RO, SE, SI, SK,
TR), OAPI (BF, BJ, CF, CG, CI, CM, GA, GN, GQ, GW,
ML, MR, NE, SN, TD, TG).

[Continued on next page]

(54) Title: STEAM IRONING DEVICE

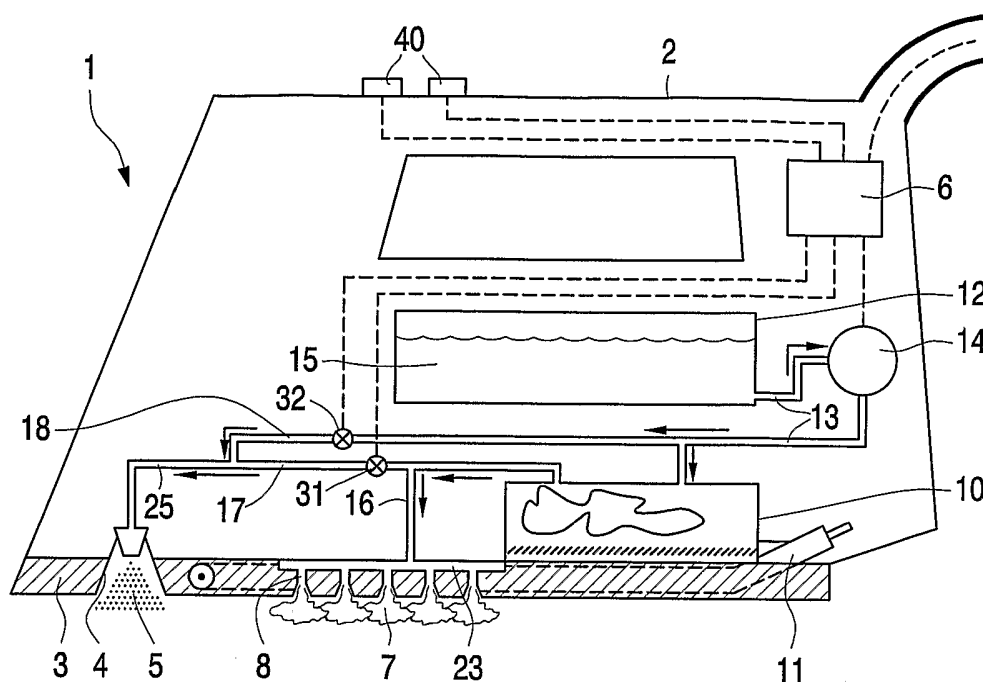

(57) **Abstract:** The invention relates to a steam ironing device with means for generating mist steam (5) as well as superheated steam (7). The soleplate (3) of the iron (1) is provided with discharge openings 4 for mist steam, preferably located in the front part of the soleplate, and with second discharge openings (8) for superheated steam.

WO 2004/085732 A1

**Declaration under Rule 4.17:**

— as to applicant's entitlement to apply for and be granted a patent (Rule 4.17(ii)) for the following designations AE, AG, AL, AM, AT, AU, AZ, BA, BB, BG, BR, BW, BY, BZ, CA, CH, CN, CO, CR, CU, CZ, DE, DK, DM, DZ, EC, EE, EG, ES, FI, GB, GD, GE, GH, GM, HR, HU, ID, IL, IN, IS, JP, KE, KG, KP, KR, KZ, LC, LK, LR, LS, LT, LU, LV, MA, MD, MG, MK, MN, MW, MX, MZ, NA, NI, NO, NZ, OM, PG, PH, PL, PT, RO, RU, SC, SD, SE, SG, SK, SL, SY, TJ, TM, TN, TR, TT, TZ, UA, UG, UZ, VC, VN, YU, ZA, ZM, ZW, ARIPO patent (BW, GH, GM, KE, LS, MW, MZ, SD, SL, SZ, TZ, UG, ZM, ZW), Eurasian patent (AM, AZ, BY,

KG, KZ, MD, RU, TJ, TM), European patent (AT, BE, BG, CH, CY, CZ, DE, DK, EE, ES, FI, FR, GB, GR, HU, IE, IT, LU, MC, NL, PL, PT, RO, SE, SI, SK, TR), OAPI patent (BF, BJ, CF, CG, CI, CM, GA, GN, GQ, GW, ML, MR, NE, SN, TD, TG)

Published:

— with international search report

For two-letter codes and other abbreviations, refer to the "Guidance Notes on Codes and Abbreviations" appearing at the beginning of each regular issue of the PCT Gazette.

PHNL030335

PCT/IB2004/050296

1

Steam ironing device

The invention relates to a steam ironing device comprising a steam iron having a housing, a soleplate at the bottom side of said housing, and at least one discharge opening in said soleplate, said device comprising means for generating mist steam and for delivering said generated mist steam from said at least one discharge opening, and control means for
5 controlling the delivery of said mist steam.

To improve the ironing result, it is generally known to moisten fabric before it is ironed. Moistening may be done, for example, by spraying water on the fabric. The fabric
10 will absorb the water and after a while the fabric has been moistened. Water may be sprayed by means of a separate container or by means of a spraying device provided on an iron. The degree to which the fabric is uniformly moistened depends on the user's skill. In general, a homogeneous moistening of the fabric will not occur.

Another manner to moisten fabric is by means of steam. Steam irons are well
15 known. During ironing, steam penetrates the fabric, thus making the removal of wrinkles easier during the subsequent ironing strokes. This manner of moistening is more convenient for the user, but the moistening itself is not very satisfactorily. Water evaporates too quickly, because the temperature of the fabric is high, often about 100°C. Often part of the steam goes through the fabric, moistening the cover layer of the ironing board, which is, of course, not
20 desired.

Still another manner to moisten fabric is by means of a spray of mist, either through a nozzle in the front part of an iron or through a delivery opening in the soleplate. The spray of mist may be obtained by atomization of cold water from the water reservoir. One example is where water is introduced into an airflow and a 2-fluid mixture thus formed
25 is ejected in a spray of mist through a nozzle. Compared with a spray of water, cold mist causes a more homogeneous moistening of the fabric. Nevertheless, the absorbed cold mist has to be heated up and evaporated during the ironing strokes. Mist may also be obtained by introducing water into a flow of steam, the 2-fluid mixture thus formed being ejected in a spray of mist through a nozzle. This kind of mist is called mist steam. An iron, capable of

PHNL030335

PCT/IB2004/050296

2

producing mist steam is known from US-A-2762143 and described in the opening paragraph above. In this connection, mist steam is to be understood as steam in which fine water droplets are incorporated, of which at least 50% of the particles have a particle size of 10-60 μm . This is much more than in a spray of water which is obtained by a spraying device of a usual spray iron where only 10-20% of the particles have a particle size of 10-60 μm .

The heat applied in the ironing process when ironing strokes are made removes moisture present in the garment from this garment. To obtain a desired ironing effect of a certain garment, in particular a garment of cellulose-type material, about six to eight strokes of ironing would have to be applied in each and every location. It is necessary that at the end of the ironing effort the garment has lost the applied moisture, to prevent a recovery of wrinkles and to resist the creation of new wrinkles due to handling and storage.

It is an object of the invention to improve an ironing device as described in the opening paragraph in order to achieve a desired ironing result with fewer ironing strokes and thus in less time compared with irons known up to now.

According to the invention, this object is achieved in that the ironing device is provided with means for generating superheated steam and with a plurality of second discharge openings in the soleplate for the delivery of said superheated steam.

The inventors have found that a substantial improvement in the ironing result, in particular for garments of cellulose-type material, can be realized by using an iron which has the capability to deliver mist steam as well as superheated steam. Superheated steam is steam heated beyond its saturation point. During the first stroke or first and second strokes of ironing of each location, the garment is sufficient moistened by the applied mist steam to bring about a more complete wrinkle relaxation. Sufficient moisture in the context of this invention means that there is a net measurable increase in the moisture content of the garment being ironed after the first stroke or the first and second strokes to an amount of 1 % to 5 %, the percentage being the moisture gained against the dry fabric weight of the garment. This requires that the amount of water introduced into the steam is between 10 to 40 g/min, more preferably from 15 to 30 g/min. The amount of steam required to atomize this amount of water is at least equal to the amount of water to be atomized. For example, to deliver 15 g/min of mist, at least 15 g/min of steam is required. In the subsequent ironing strokes only superheated steam is applied to the location being ironed. The superheated steam helps to distribute the previously applied moisture in the garment more uniformly and helps to

PHNL030335

PCT/IB2004/050296

3

achieve a thorough heating-up of the garment. The moistened garment, heated up by superheated steam, is smoothened, flattened, and dried by the hot soleplate. It has been observed that often no more than three or four ironing strokes are sufficient to achieve a very good ironing result. For example, one or two strokes for applying mist steam, followed by two strokes with superheated steam. This is substantially less than can be achieved with known irons on the market at present.

It will be clear that the control means enables the user to decide when and, if desired, how much mist is applied.

In a preferred embodiment of the ironing device, said at least one discharge opening for mist steam is provided in a tip area of the soleplate. The tip area of the soleplate is pointed so as to iron difficult areas of clothes such as corners, pockets, in between buttons, etc., more easily. These areas can be moistened better in that the mist discharge opening is provided in the tip area of the soleplate.

A further preferred embodiment of the ironing device is characterized in that the device comprises

- a steam generator,
- heating means for heating said steam generator,
- water supply means,
- a water passage between the water supply means and the steam generator,
- an electric pump for the delivery of water through said water passage from the water supply means to the steam generator,

and said iron comprises

- a first steam passage between the steam generator and said plurality of steam discharge openings for the delivery of superheated steam,
- a second steam passage between the steam generator and the at least one mist discharge opening, and
- a second water passage between the pump and the second steam passage.

Only one steam generator and one pump are necessary to generate superheated steam and mist steam. Said superheated steam is delivered through the second discharge openings. Mist steam is obtained by introducing water into the superheated steam and to deliver the resultant 2-fluid mixture through the mist steam discharge opening.

It also possible to provide the iron with a heated chamber or a heated channel or a combination thereof located downstream of the steam generator to be sure that the steam delivered through the discharge openings is superheated.

PHNL030335

PCT/IB2004/050296

4

Another embodiment of the ironing device described above comprises a water supply station, separate from said iron, said water supply station comprising a water reservoir and said electric pump. In this embodiment, the water reservoir can be made much larger, which is convenient during a long ironing period. Also the control means may be located in such a station. The water supply station is connected to the iron by means of a flexible tube.

A further embodiment of the ironing device is characterized in that the steam passage between the steam generator and the steam discharge openings for superheated steam comprises a pressure-dependent valve. This valve limits the steam flow to the steam discharge opening, causing the steam flow to be directed to the mist discharge opening. Due to the small size of the mist delivery opening, pressure is built up rapidly for proper mist generation. When the pressure reaches a predetermined value, the excess steam will escape via the pressure-dependent valve. The delivery of large water droplets to the garment is thus avoided.

Another embodiment of the ironing device is characterized in that the device comprises

- a steam generator for the generation of mist steam,
 - water supply means,
 - a water passage between the water supply means and the steam generator,
 - an electric pump for the delivery of water through said water passage from the water supply means to the steam generator,
- and said iron comprises
- a heated chamber for generating said superheated steam, said heated chamber being located downstream of the steam generator and being in communication with said plurality of steam discharge openings,
 - a first steam passage between the steam generator and said heated chamber,
 - a second steam passage between the steam generator and said at least one mist discharge opening,

said device further comprising heating means for heating said steam generator and said heated chamber.

Mist steam is generated in the steam generator in this embodiment. The generated mist steam may be used to deliver the mist steam directly through the mist discharge opening(s), without the necessity to mix it with water. The generated mist steam may alternatively be heated up to superheated steam in the heated chamber to be delivered through the plurality of discharge openings for superheated steam.

PHNL030335

PCT/IB2004/050296

5

Another embodiment of the ironing device described above comprises a steam generating station, separate from said iron, said steam generating station comprising a water reservoir, said steam generator for generating mist steam, and said electric pump. More components of the device are located in a separate housing in this embodiment, so that the iron can be made lightweight. Moreover, the water reservoir and the steam chamber for generating mist steam can be made larger.

Another embodiment of the ironing device described above comprises a steam generating station, separate from said iron, said steam generating station comprising a boiler for generating hot water and steam,

10 which steam generating station comprises

- a first steam passage connecting a steam space of the boiler with the iron,
- a water passage between said boiler and said first steam passage for introducing hot water into said first steam passage,

said iron comprising

- 15 - a heated chamber in communication with the first steam passage for generating superheated steam, said heated chamber being located downstream of the boiler and being in communication with said plurality of second discharge openings,
- a second steam passage connecting the first steam passage with said at least one mist discharge opening,

20 said device further comprising heating means for heating said heated chamber and said boiler.

In this embodiment there is no cold water reservoir, but a boiler which contains an amount of hot boiling water and saturated steam in the steam space above the water level in operation. Saturated steam is heated further to superheated steam in the heated chamber. Hot water is introduced into the saturated steam, which flows through the first steam passage, so that a 2-fluid mixture is obtained. In the iron, the 2-fluid mixture then flows into the second steam passage toward the mist discharge opening. In contrast to the other embodiment, hot water instead of cold water is now introduced into the steam, so that cooling-down of the steam is limited.

30 A further embodiment of the described ironing device is characterized in that the iron comprises a flow divider, and that the soleplate comprises a plurality of mist discharge openings, each opening being connected to the flow divider by means of a mist steam passage. A higher number of mist discharge openings improves the uniform moistening of the garment.

PHNL030335

PCT/IB2004/050296

6

Still another embodiment of the ironing device is characterized in that the iron is provided with a cartridge for additive liquid and means for adding said additive liquid to the mist steam. Adding an additive liquid to the mist steam may have several advantages such as an improved wrinkling resistance and an easier gliding of the iron over the garment. If the additive liquid is in a concentrated form, the liquid may be diluted with water from the water reservoir.

The ironing device according to the invention may also be provided with a spray nozzle in the front part of the housing of the iron so as to spray water or mist steam, possibly combined with additive liquid, directly onto the garment to be ironed.

To enable the user to operate the ironing device in its several modes, the water and steam passages in the iron are provided with one or more valves which are operable by means of one or more buttons on the housing of the iron.

Control means are provided to bring about the sequential delivery of steam mist and superheated steam. One example of such control means is a mechanical or electromechanical valve that selectively directs the steam from the steam generator to the steam mist generation nozzles or the heated chamber. Said mechanical or electromechanical valve is actuated by a switch. Yet another mechanical or electromechanical valve is provided to direct water selectively into the steam passage, terminating at the steam mist generation nozzle.

These and other aspects of the invention will be apparent from and elucidated with reference to the embodiments described hereinafter.

In the drawings:

Fig.1 is a diagrammatic cross-sectional view of a steam iron of a steam ironing device according to a first embodiment,

Fig.2 is a diagrammatic cross-sectional view of a steam ironing device with a water supply station according to a second embodiment,

Fig.3 is a diagrammatic cross-sectional view of a steam iron of a steam ironing device including a cartridge for additive liquid according to a third embodiment,

Fig.4 is a bottom view of the soleplate of the steam iron of a steam ironing device showing the discharge openings for mist steam and superheated steam,

Fig.5 is a diagrammatic cross-sectional view of a steam iron of a steam ironing device according to a fourth embodiment,

PHNL030335

PCT/IB2004/050296

7

Fig.6 is a diagrammatic cross-sectional view of a steam ironing device with a steam generation station according to a fifth embodiment,

Fig.7 is a diagrammatic cross-sectional view of a steam iron of a steam ironing device according to a sixth embodiment, and

5 Fig.8 is a diagrammatic cross-sectional view of a steam ironing device with a steam generation station comprising a boiler according to a seventh embodiment.

Throughout all embodiments similar parts of the ironing device are indicated
10 with the same reference numerals.

The steam ironing device of the first embodiment (Fig.1) consist of a steam iron 1 having a housing 2 with a soleplate 3 at the bottom side of the housing. A water reservoir 12, an electric pump 14, a steam generator 10, and control means 6 are
accommodated inside the housing. User-operable control buttons 40 are provided on the
15 housing 2 to control several function of the device. The soleplate 3 of the iron is provided with two different types of steam discharge openings. Discharge opening 4, located in the tip area of the soleplate, is for the delivery of mist steam, and second discharge openings 8 are for the delivery of superheated steam 7. A water passage 13 connects the water reservoir 12 with the electric pump 14 and the electric pump with the steam generator 10. A first steam
20 passage 16 connects the steam generator 10 with the second discharge openings 8. A second steam passage 17 connects the steam generator 10 with the discharge opening 4. In the embodiment, the second steam passage 17 branches off from the first steam passage 16. A second water passage 18 connects the electric pump 14 with the second steam passage 17. In the embodiment, the second water passage 18 branches off from the water passage 13. The
25 iron is further provided with a heating element 11 for heating the soleplate 3 and for heating the steam generator 10.

In operation, when the iron is powered, the user can decide to perform the ironing task with the aid of steam. The user can start the electric pump 14 to pump water 15 from the water reservoir 12 to the steam generator 10 by means of one of the control buttons
30 40. The flow rate of the water is adjusted with one of the buttons 40. Water is heated in the steam generator so as to obtain superheated steam 7. The superheated steam is forced via distribution channels 23 located in the soleplate 3 to the second discharge openings 8. As the distribution channels are located in the hot soleplate any condensation of the superheated steam is prevented. The user can open adjustable valves 31, 32 in the second steam passage

PHNL030335

PCT/IB2004/050296

8

17 and the second water passage 18 with one of the buttons 40. Water is then introduced into the second steam passage 17, which results in the formation of mist steam 5. The mist steam 5 is delivered through the discharge opening 4. The mist steam rate and the amount of water introduced into the steam can be adjusted by the user.

5 The steam ironing device of the second embodiment (Fig.2) comprises a steam iron 1 and a water supply station 50. The steam iron 1 differs from the steam iron of the first embodiment in that the water reservoir 12 and the electric pump 14 are now accommodated in the station 50. Compared with the ironing device of Fig.1, the water reservoir can now have a much bigger volume. Preferably, the control unit 6 is also accommodated in the
10 station 50. The operation of the ironing device is similar to that of the first embodiment in Fig.1.

 The steam ironing device of the third embodiment (Fig.3) is an extension of the device of the first embodiment. The iron 1 comprises several additional features. Firstly, the steam generator now produces normal steam instead of superheated steam. This means
15 that this normal steam should be heated up to superheated steam 7 before it is delivered from the second discharge openings 8. The iron is provided with a heated chamber 20 for this purpose. This heated chamber 20 is preferably located in the soleplate 3 and heated by the same heating element 11 that heats the soleplate. The iron may additionally be provided with a pressure-dependent valve 19 located in the first steam passage 16. This ensure that excess
20 steam can escape via the pressure-dependent valve 19. Secondly, there are a number of discharge openings 4 for the delivery of mist steam 5. To this end the iron is provided with a flow divider 24 located downstream of the mist steam passage 25. The discharge openings 4 are each connected with the flow divider 24 through mist steam passages 25a. These discharge openings are located in the tip area 9 of the soleplate 3 as shown in Fig.4. A third
25 feature is the provision of a cartridge 26 containing an additive liquid 27. Additive liquids may be used e.g. for improving the wrinkle resistance of the clothes to be ironed or a better gliding of the soleplate over the garment. The additive liquid can be added to the mist steam so as to be delivered through the discharge openings 4. The second water passage 18 for the delivery of mist steam is now separate from the first water passage 13. The iron is provided
30 with a second pump 38 for pumping water 15 through the second water passage 18 to the second steam passage 17. An additive liquid passage 28 connects the cartridge with the second water passage 18. An (adjustable) valve 33 in the additive liquid passage 28 enables the user to control the addition of additive liquid to the mist steam. A final feature is the provision of a spray nozzle 29 in the lower front part 30 of the housing 2. The spray nozzle

PHNL030335

PCT/IB2004/050296

29 is connected to the mist steam passage 25 through a passage 39. The passage 39 can be opened or closed by means of a valve 34, which is operable by the user via a button on the housing of the iron.

In the fourth embodiment (Fig.5) the iron 1 of the steam ironing device
5 comprises a steam generator 10 for generating mist steam 5. For the generation of superheated steam 7, the steam generator 10 is connected to a heated chamber 20 by means of a second steam passage 21. The heated chamber 20 is connected with the second discharge openings 8 by means of distribution channels (not shown). The mist steam generator 10 is also connected to the mist steam discharge opening 4 by a second steam passage 25. This
10 second steam passage 25 branches off from the first steam passage 21. Opening of a valve 35 in the first steam passage 21 forces the mist steam 5 through the second steam passage 25 toward the mist discharge opening 4. The advantage of this embodiment is that mist steam is generated in the steam generator 10, so that it is not necessary to introduce water into a steam passage to obtain mist steam.

15 The steam ironing device of the fifth embodiment (Fig.6) comprises a steam iron 1 and a steam generating station 60. The steam iron 1 differs from the steam iron of the fourth embodiment in that the steam generator 10, the water reservoir 12 and the electric pump 14 are now accommodated in the station 60. The control unit 6 may also be accommodated in the station 60. The operation of the ironing device is similar to that of the
20 fourth embodiment in other respects.

The steam ironing device of the sixth embodiment (Fig.7) is an extension of the fourth embodiment. As in the third embodiment, the iron 1 is provided with additional features such as the flow divider 24 and spray nozzle 29. A three-way valve 35 can direct mist steam either to the discharge openings 4 or to the nozzle 29.

25 The steam ironing device of the seventh embodiment (Fig.8) differs from the fifth embodiment in that the steam generating station 60 now comprises a boiler 10 for the generation of steam. A pump and a cold water reservoir are not necessary. The boiler is heated by a heating element 44 at the bottom of the boiler. In operation, water in the boiler is heated to boiling point. The boiler is then pressurized. The space 45 above the water level
30 contains saturated steam. Opening of a valve 37 in a first steam passage 21 causes steam to flow through the first steam passage 21 to the heated chamber 20 of the iron 1. In this heated chamber 20, the steam is further heated to superheated steam 7, which is discharged through the openings 8. The valve 37 can be opened by means of a trigger 40a on the iron. A water passage 41 is connected between the boiler 10 and the first steam passage 21 for generating

PHNL030335

PCT/IB2004/050296

10

mist steam. Opening of the valve 36 adds hot water to the steam in the first steam passage 21. The hot water mixes with the saturated steam, and a 2-fluid mixture is obtained in this way. The 2-fluid mixture flows through the first steam passage 21 to the iron and via the second steam passage 25 to the mist discharge opening(s) 4. The valve 36 can be opened or closed
5 by means of one of the buttons 40. The amount of hot water introduced into the first steam passage 21 can be regulated by means of an adjustable restriction 42 in the water passage 41. If mist steam is generated, the mist steam will also flow into the heated chamber 20. This represents no problem because the mist steam can easily be heated up in this heated chamber to superheated steam. If only superheated steam is required, the valves 35 and 36 are closed.
10 When the boiler is depressurized, the boiler can be filled with water through the filling cap 43.

The iron may also be provided with a flow divider 24 to deliver mist steam 5 through a number of openings 4 in the soleplate in this embodiment, or with a spray nozzle 29 for spraying mist steam on the garment, as shown in Fig.7.

PHNL030335

PCT/IB2004/050296

11

CLAIMS:

1. A steam ironing device comprising a steam iron (1) having a housing (2), a soleplate (3) at the bottom side of said housing, and at least one discharge opening (4) in said soleplate (3), said device comprising means for generating mist steam (5) and for delivering said generated mist steam (5) from said at least one discharge opening (4), and control means (6) for controlling the delivery of said mist steam (5), characterized in that the iron (1) is provided with means for generating superheated steam (7) and with a plurality of second discharge openings (8) in the soleplate (3) for the delivery of said superheated steam (7).
2. A steam ironing device as claimed in claim 1, characterized in that said at least one mist steam discharge opening (4) for mist steam (5) is provided in a tip area (9) of the soleplate (3).
3. A steam ironing device as claimed in claim 1 or 2, characterized in that the device comprises
- a steam generator (10),
 - heating means (11) for heating said steam generator (10),
 - water supply means (12),
 - a water passage (13) between the water supply means (12) and the steam generator (10),
 - an electric pump (14) for the delivery of water (15) through said water passage (13) from the water supply means (12) to the steam generator (10),
- and said iron (1) comprises
- a first steam passage (16) between the steam generator (10) and said plurality of second discharge openings (8) for the delivery of superheated steam (7),
 - a second steam passage (17) between the steam generator (10) and the at least one mist discharge opening (4), and
 - a second water passage (18) between the pump (14) and the second steam passage (17).

PHNL030335

PCT/IB2004/050296

12

4. A steam ironing device as claimed in claim 3, characterized in that the iron comprises a heated chamber (20) or heated channel or a combination thereof located downstream of the first steam passage (16) for generating superheated steam (7).
5. A steam ironing device as claimed in claim 3 or 4, characterized in that the device comprises a water supply station (50), separate from said iron (1), said water supply station (50) comprising a water reservoir (12) and said electric pump (14).
6. A steam iron as claimed in claim 3, 4, or 5, characterized in that the first steam passage (16) between the steam generator (10) and the second steam discharge openings (8) for superheated steam (7) comprises a pressure-dependent valve (19).
7. A steam iron as claimed in claim 1 or 2, characterized in that the device comprises
- a steam generator (10) for generating mist steam (5),
 - water supply means (12),
 - a water passage (13) between the water supply means (12) and the steam generator (10),
 - an electric pump (14) for the delivery of water (15) through said water passage (13) from the water supply means (12) to the steam generator (10),
- and said iron comprises
- a heated chamber (20) for generating superheated steam (7), said heated chamber (20) being located downstream of the steam generator (10) and being in communication with said plurality of second discharge openings (8),
 - a first steam passage (21) between the steam generator (10) and the heated chamber (20),
 - a second steam passage (25) between the steam generator (10) and said at least one mist discharge opening (4),
- said device further comprising heating means for heating said steam generator (10) and said heated chamber (20).
8. A steam ironing device as claimed in claim 7, characterized in that the device comprises a steam generating station (60), separate from said iron (1), said steam generating station (60) comprising a water reservoir (12), said steam generator (10) for generating mist steam (5), and said electric pump (14).

PHNL030335

PCT/IB2004/050296

13

9. A steam iron as claimed in claim 1 or 2, characterized in that the device comprises a steam generating station (60), separate from said iron (1), which steam generating station (60) comprises a boiler (10) for generating hot water (15) and steam, said steam generating station (60) further comprising
- 5
- a first steam passage (21) connecting a steam space (45) of the boiler with the iron (1),
 - a water passage (41) between said boiler (10) and said first steam passage (21) for introducing hot water (15) into said first steam passage (21),
- and said iron comprising
- 10
- a heated chamber (20) in communication with said first steam passage (21) for generating superheated steam (7), said heated chamber (20) being located downstream of the boiler (10) and being in communication with said plurality of second discharge openings (8),
 - a first steam passage (21) between the boiler (10) and the heated chamber (20),
 - a second steam passage (25) between the boiler (10) and said at least one mist discharge
- 15 opening (4),
- said device further comprising heating means (11, 44) for heating said heated chamber (20) and said boiler (10).
10. A steam ironing device as claimed in any one of the claims 3 to 9,
- 20 characterized in that the iron (1) comprises a flow divider (24), and in that the soleplate (3) comprises a plurality of mist discharge openings (4), each opening (4) being connected to the flow divider (24) by means of a mist steam passage (25).
11. A steam ironing device as claimed in claim 3, 4, or 5, characterized in that the
- 25 iron (1) is provided with a cartridge (26) for additive liquid (27) and with means for adding said additive liquid (27) to the mist steam (5).
12. A steam ironing device as claimed in claim 11, characterized in that the iron
- (1) comprises an additive liquid passage (28) for connecting the cartridge (26) with the
- 30 second water passage (18) so as to obtain a diluted additive liquid downstream of said second water passage (18).
13. A steam ironing device as claimed in any one of the claims 1 to 12,
- characterized in that the iron (1) is provided with a spray nozzle (29) in the front part (30) of

PHNL030335

PCT/IB2004/050296

the housing (2).

14. A steam ironing device as claimed in any one of the claims 1 to 12,
characterized in that the iron (1) comprises valve means (31-37) for adjusting the amount of
5 mist steam (5) and superheated steam (7) supplied to the respective discharge openings (4, 8).

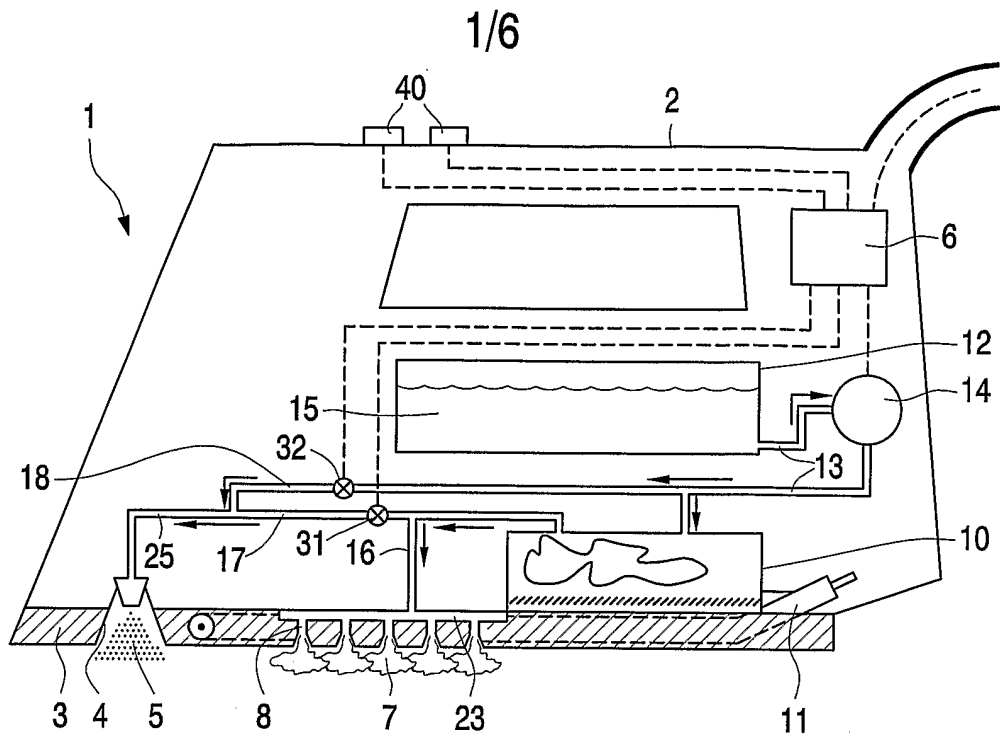

Fig.1

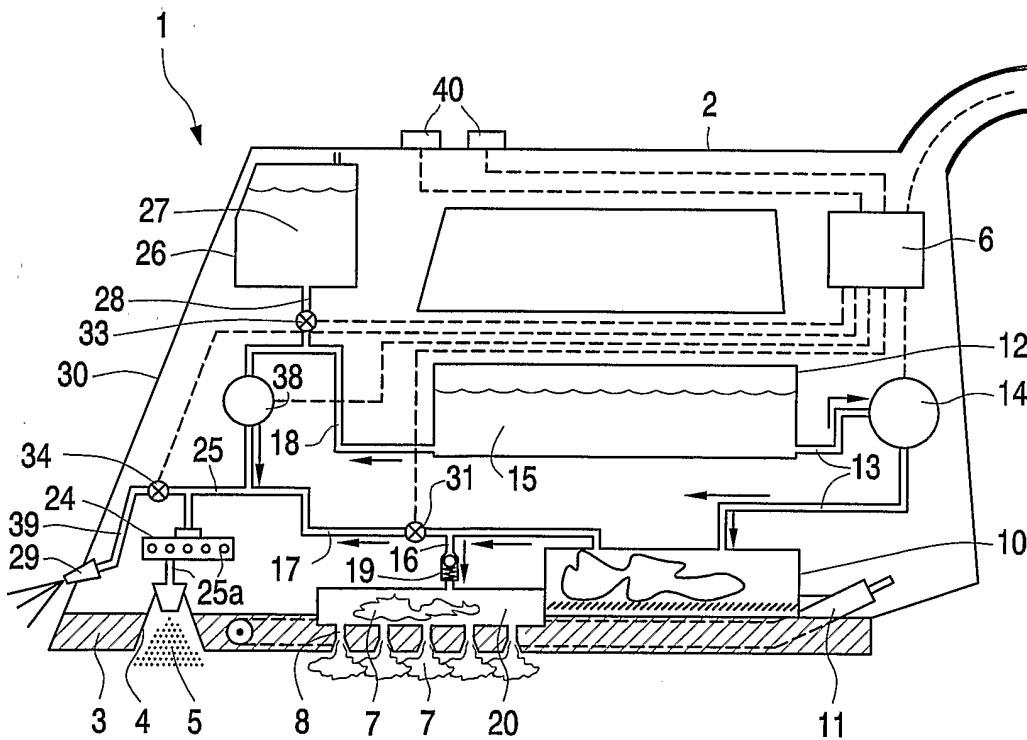

Fig.3

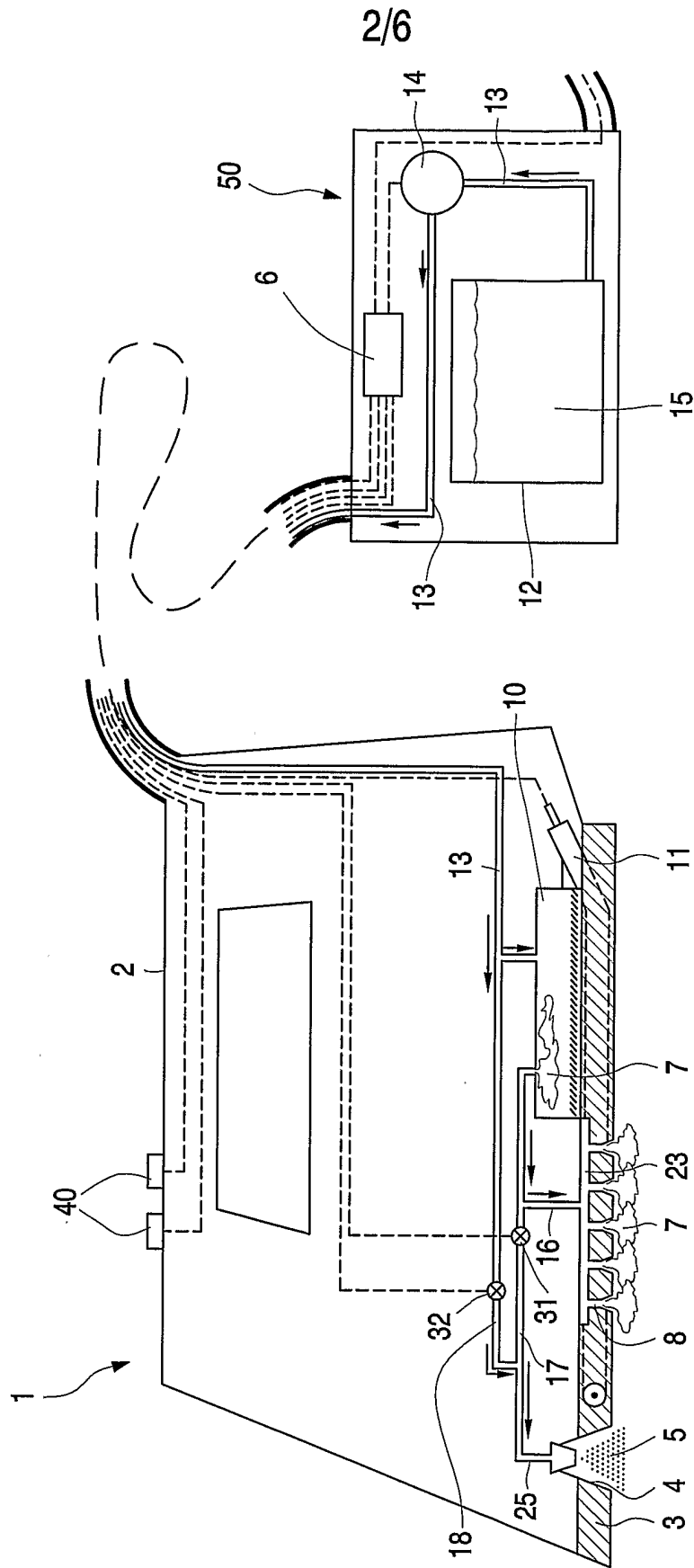

Fig.2

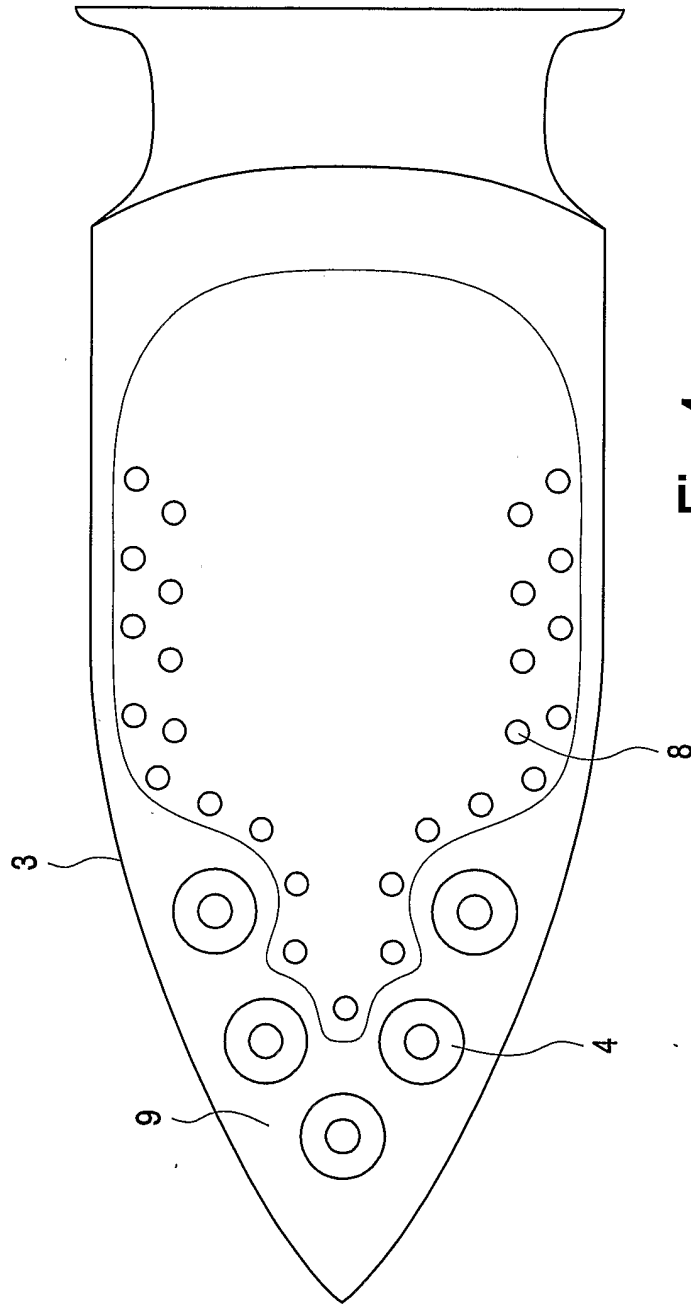

Fig.4

4/6

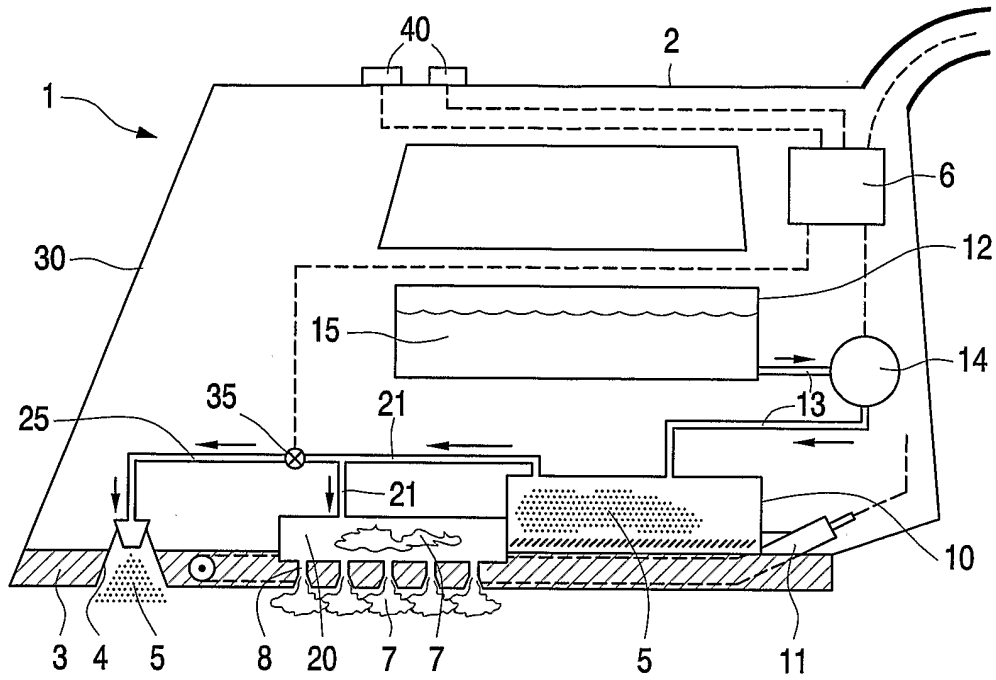

Fig.5

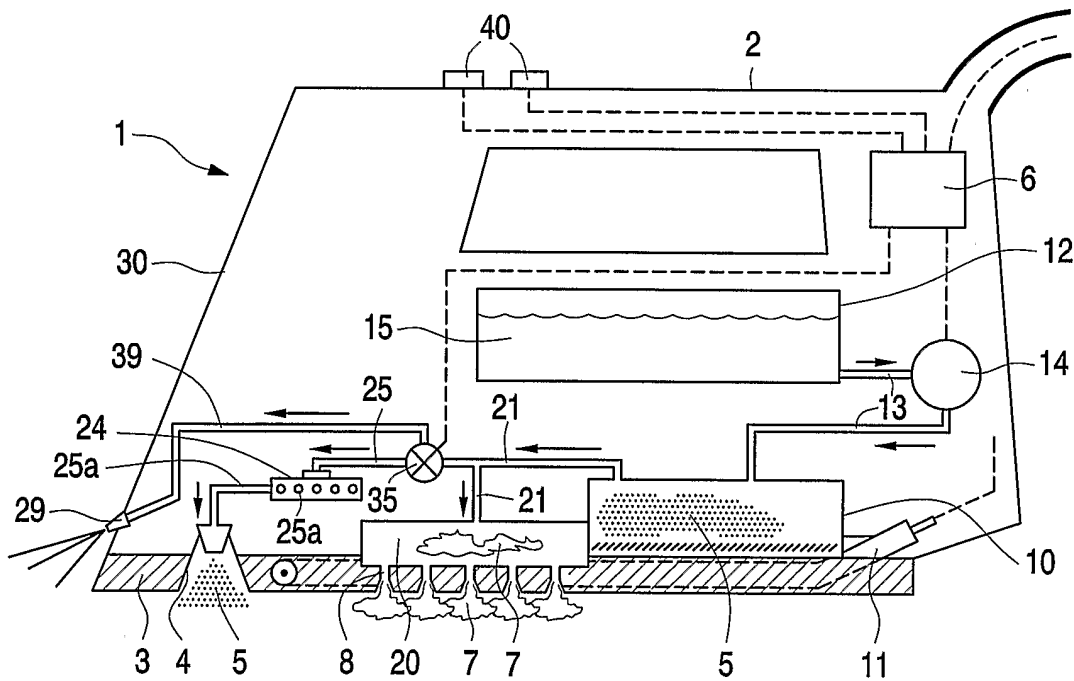

Fig.7

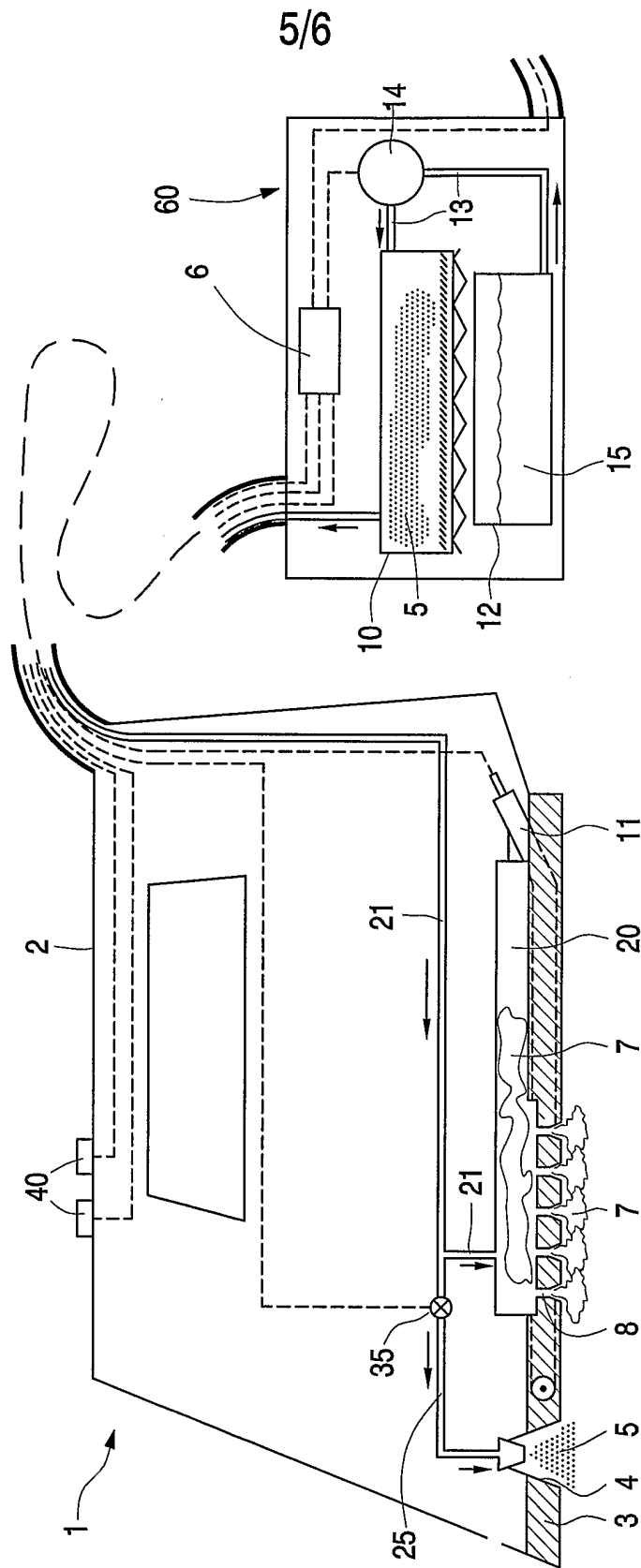

Fig.6

6/6

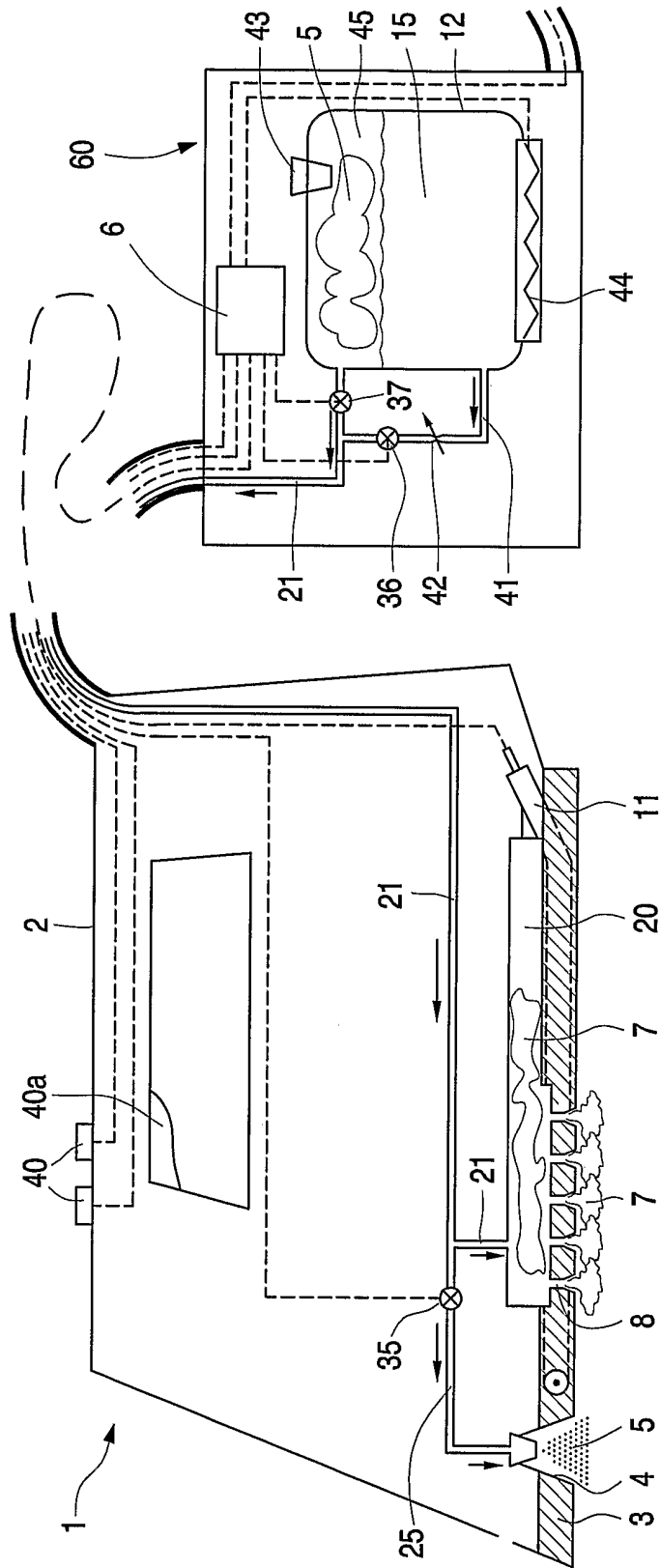

Fig.8

INTERNATIONAL SEARCH REPORT

International Application No
PCT/IB2004/050296

A. CLASSIFICATION OF SUBJECT MATTER
IPC 7 D06F75/10 D06F75/22

According to International Patent Classification (IPC) or to both national classification and IPC

B. FIELDS SEARCHED

Minimum documentation searched (classification system followed by classification symbols)
IPC 7 D06F

Documentation searched other than minimum documentation to the extent that such documents are included in the fields searched

Electronic data base consulted during the international search (name of data base and, where practical, search terms used)
EPO-Internal, PAJ

C. DOCUMENTS CONSIDERED TO BE RELEVANT

Category °	Citation of document, with indication, where appropriate, of the relevant passages	Relevant to claim No.
X	PATENT ABSTRACTS OF JAPAN vol. 018, no. 381 (C-1226), 18 July 1994 (1994-07-18) -& JP 06 105996 A (TOSHIBA HOME TECHNOL CORP), 19 April 1994 (1994-04-19)	1,13,14
A	abstract the whole document	2-4,6,7, 10
X	DE 43 15 800 A (KNORR WILFRIED) 24 November 1994 (1994-11-24)	1,2,14
A	column 1, line 1-44 column 3, line 38 -column 5, line 12; figure 3	3-10
	-/--	

Further documents are listed in the continuation of box C.

Patent family members are listed in annex.

° Special categories of cited documents :

- "A" document defining the general state of the art which is not considered to be of particular relevance
- "E" earlier document but published on or after the international filing date
- "L" document which may throw doubts on priority claim(s) or which is cited to establish the publication date of another citation or other special reason (as specified)
- "O" document referring to an oral disclosure, use, exhibition or other means
- "P" document published prior to the international filing date but later than the priority date claimed

- "T" later document published after the international filing date or priority date and not in conflict with the application but cited to understand the principle or theory underlying the invention
- "X" document of particular relevance; the claimed invention cannot be considered novel or cannot be considered to involve an inventive step when the document is taken alone
- "Y" document of particular relevance; the claimed invention cannot be considered to involve an inventive step when the document is combined with one or more other such documents, such combination being obvious to a person skilled in the art.
- "&" document member of the same patent family

Date of the actual completion of the international search

24 June 2004

Date of mailing of the international search report

13/07/2004

Name and mailing address of the ISA

European Patent Office, P.B. 5818 Patentlaan 2
NL - 2280 HV Rijswijk
Tel. (+31-70) 340-2040, Tx. 31 651 epo nl,
Fax: (+31-70) 340-3016

Authorized officer

Falkentoft, C

INTERNATIONAL SEARCH REPORT

International Application No
PCT/IB2004/050296

C.(Continuation) DOCUMENTS CONSIDERED TO BE RELEVANT

Category	Citation of document, with indication, where appropriate, of the relevant passages	Relevant to claim No.
X A	JP 59 037999 A (MATSUSHITA ELECTRIC IND CO LTD) 1 March 1984 (1984-03-01) figures 1,4	1,2,14 3,4,6,7, 13
X A	WO 01/57302 A (KONINKL PHILIPS ELECTRONICS NV) 9 August 2001 (2001-08-09) page 3, line 16-34 page 5, line 8-11; figure 1	1,14 3,7,11, 13
A	US 6 009 645 A (SHIMIZU MASAO ET AL) 4 January 2000 (2000-01-04) abstract column 2, line 29 -column 3, line 11 column 8, line 4 -column 10, line 15; figures	1-3,6,7, 13,14
A	US 3 002 302 A (FLOWERS THEODORE R) 3 October 1961 (1961-10-03) column 1, line 1 -column 5, line 33; figures 1-3	1-3,6,7, 14
A	GB 587 802 A (GEORGE HENRY WILKINSON) 6 May 1947 (1947-05-06) the whole document	1,3,4,7, 9
P,A	WO 03/052194 A (GUO TAO ; WONG NYIK S (NL); YONG JIANG (NL); ASOK S O KASEVAN KUMAR (N) 26 June 2003 (2003-06-26) the whole document	1-14

INTERNATIONAL SEARCH REPORT

Information on patent family members

International Application No

PCT/IB2004/050296

Patent document cited in search report		Publication date	Patent family member(s)	Publication date
JP 06105996	A	19-04-1994	NONE	
DE 4315800	A	24-11-1994	DE 4315800 A1 AU 6843994 A WO 9426966 A1	24-11-1994 12-12-1994 24-11-1994
JP 59037999	A	01-03-1984	JP 1706605 C JP 3075198 B	27-10-1992 29-11-1991
WO 0157302	A	09-08-2001	SG 86370 A1 CN 1363004 T WO 0157302 A1 EP 1169510 A1 JP 2003521320 T US 2001042326 A1	19-02-2002 07-08-2002 09-08-2001 09-01-2002 15-07-2003 22-11-2001
US 6009645	A	04-01-2000	JP 3257451 B2 JP 10328498 A JP 3257465 B2 JP 11076699 A JP 3430880 B2 JP 11090098 A JP 3119212 B2 JP 11090097 A CN 1203291 A ,B	18-02-2002 15-12-1998 18-02-2002 23-03-1999 28-07-2003 06-04-1999 18-12-2000 06-04-1999 30-12-1998
US 3002302	A	03-10-1961	US 3041757 A US 3041756 A DE 1082220 B FR 1209989 A GB 890558 A DE 1095779 B GB 881434 A DE 1082221 B GB 892512 A	03-07-1962 03-07-1962 25-05-1960 04-03-1960 07-03-1962 29-12-1960 01-11-1961 25-05-1960 28-03-1962
GB 587802	A	06-05-1947	NONE	
WO 03052194	A	26-06-2003	SG 98046 A1 WO 03052194 A1	20-08-2003 26-06-2003