

J. EIBERWEISER.

Cider Press

No. 18,895.

Patented Dec. 22, 1857.

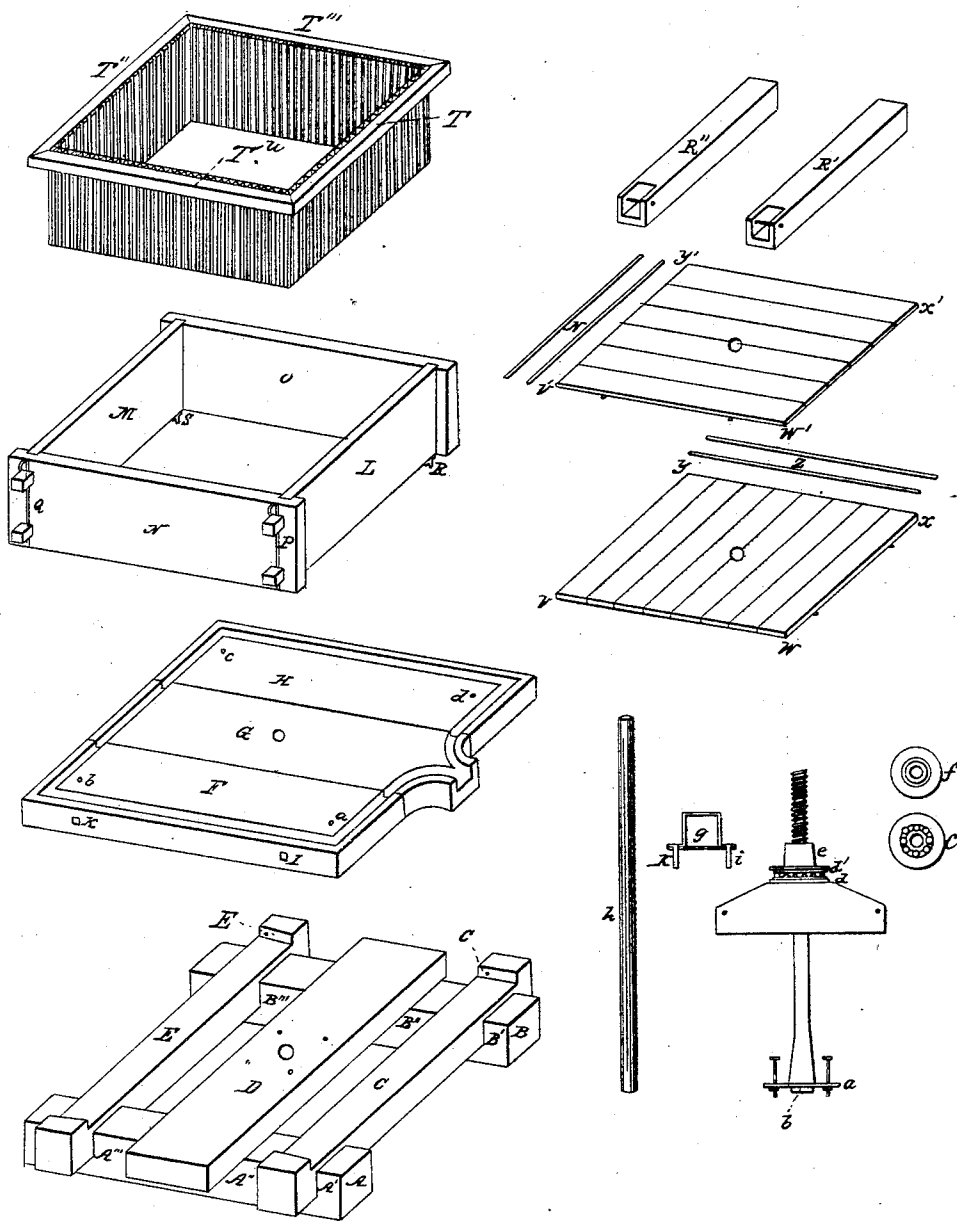

Witnesses:

John R. ...
John C. ...

Inventor:

J. Eiberweiser

UNITED STATES PATENT OFFICE.

JOHN EIBERWEISER, OF CINCINNATI, OHIO.

WINE AND CIDER PRESS.

Specification of Letters Patent No. 18,895, dated December 22, 1857.

To all whom it may concern:

Be it known that I, JOHN EIBERWEISER, of Cincinnati, in the county of Hamilton, in the State of Ohio, have invented new and useful Improvements in Wine and Cider Presses; and I do hereby declare that the following is a full, clear, and exact description of the construction and operation of the same, reference being had to the annexed drawings, and to the respective letters on them, making a part of this specification, in which drawings all the parts are viewed in perspective, except the screw and its appendages, which are represented in a front view.

The nature of my improvements consists in constructing the platform so that no wine or cider will be wasted, that it flow easily to the receiver, and that the sides of the double box may be taken away the more easily in order to remove the dregs, without disturbing the platform, or any of the other sides of the box; then it consists of a double box, so constructed, as to let the juice flow freely from the grape, without loss, and free from the dregs, which in other presses generally flow with the juice; then it consists of a screw and its appendages, so constructed that the foot of the screw being conical will prevent any loss of juice through the hole, through which it passes in the platform F G H; and as to its appendages by applying iron balls between two smooth surfaces (as *e* and *c*) to give greater power, and to prevent nearly all friction.

To enable others not skilled in the art to make and use my improvement, I will proceed to describe its construction and operation.

The press consists of 5 main parts, the foundation or trestle, the platform, the outside box, the inside box (which when placed one within the other make a double box), and the screw and its appendages.

The Figures V W X Y and *v' w' x' y'*, represent only plain boards, and Z and Z' 4 staves, placed under the first and second platform, preparatory to pressing.

R' and R'' are beams which are placed over the 2nd layer preparatory to pressing.

The foundation or trestle consists of 5 beams, two A B parallel and horizontal and 3 C D E transverse of A B. The middle D is wider than the rest, beneath it the screw is fastened. Upon the 3 beams C D E the platform F G H rests, and is fastened

by wedges placed between it and the projections of the beams C and E. It is surrounded by a groove cut into it in which the wine flows to the receiver from the projection in the middle board G. The boards which compose the platform are fastened together by two iron pins, going through them.

The outside box consists of 4 sides put together by tenets projecting from the ends of two side boards, and fitting in holes made in the two other side boards; and iron pins going through the tenets hold the sides firmly together as may be seen in the drawing at P and Q.

L M N O represent the box. This box is raised a little above the platform to let the juice go through. The inside box is made to fit the inside of the outside box. It consists of narrow strips of wood, one side of which is cut like a truncated pyramid. These strips are screwed, with the narrower or truncated side inward to iron below, and to wood strips T T' T'' T''' above, (which angle at the ends with each other) so that it will appear like a funnel the larger opening being between the inside and outside box. The strips T T' T'' T''' rest on the top of the sides of the outside box; and the strips or lathe work, touches the platform below. Each side of the inside box is separate and free from the other, so that it can be taken out separately, or one at a time.

The screw is as an ordinary large screw only being conical at the bottom for the length of about a foot, and is permanently forged at the bottom to a square iron plate. This plate is screwed to the bottom of the beam D of the trestle, through which the screw goes. The screw next passes through the middle of the platform F, G, H. Now because of the screw being conical at the bottom, when the upper block of the appendage of the screw is pressed down, the lower part of the screw will be pressed upward, and consequently press in, and fill up most tightly the hole in G of the platform, and allow no juice to escape there. The appendages of the screw are the upper block, the lower nut *c*, and the upper nut *e*, the clamp and the bar. The upper block has an internal screw to fit the main screw, and is fastened to the nut *c*. The nut *c* has also an internal screw to fit the outer screw;—it has two immovable circumferences, one covered by the ring *d*, which is the smaller,

and the other at *c*. The flat surface of the lower nut is represented by the separate section *c*; and it is there seen that its flat surface has a circular groove in which iron balls will run.

5 *e* is the upper nut, similar to the lower nut, only having a larger square at *e* above solidly fastened to it, and which the clamp *g* will embrace. The section *f* represents the flat surface of the nut, and it will be
10 seen that it also has an internal screw, and two circumferences of different diameter. Around the smaller circumference of the lower nut is a ring *d*, which may move
15 loosely around it. Another similar ring *d'* is placed around the smaller circumference of the upper nut. Between the two flat surfaces, and in the grooves of the lower and upper nut are placed spherical iron
20 balls, as many as will cover the entire circle of the grooves. Now the upper nut being put on the balls on the surface of the lower nut, and the two rings *d* and *d'* being fastened together, by four or more screws, all
25 the appendages of the screw are fastened together, so that they will altogether move up when the lever winds up, and go down when the lever winds down, without any

further trouble whatever. And if they be pressed down, when the upper block comes 30 to rest on the cross beams *R'* and *R''*, which lie across the upper layer, and the pressure be continued nothing more will move except the lever and the upper nut, which will move over the spherical balls; and here the 35 friction is removed by the balls, which would otherwise be caused by two flat surfaces moving on each other.

h is a bar or lever, which is put through the circles *k* and *i* of the clamp *g*, so that 40 either one or two men may press continually without the interruption caused by changing the lever.

Now what I claim as my improvement is— 45

The peculiar construction and arrangement of the platform, and the double box on a wine and cider press constructed in such a manner as above described.

I claim Letters Patent thereon and I con- 50 fine my claim now to a press with the above improvements.

JOHN EIBERWEISER.

Witnesses:

JOHN RIECKELMANN,
JOHN CLOSS.