

J. E. KEY.
MILLING MACHINE.
APPLICATION FILED NOV. 13, 1905.

4 SHEETS—SHEET 1.

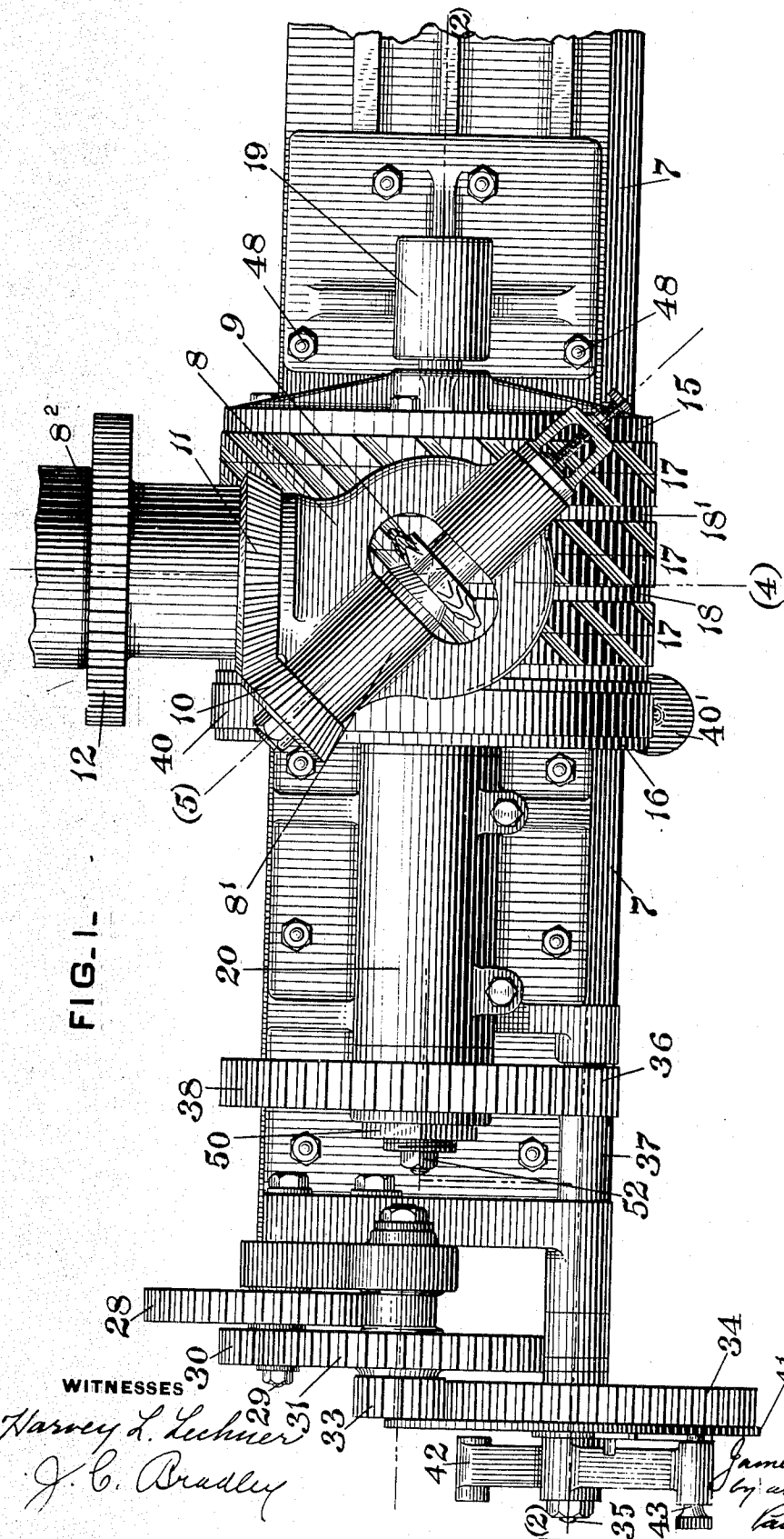

FIG. 1-

WITNESSES

Harvey L. Lechner
J. C. Bradley

INVENTOR

James E. Key
By atty
Paul Symonds

J. E. KEY.
MILLING MACHINE.
APPLICATION FILED NOV. 13, 1905.

4 SHEETS—SHEET 2.

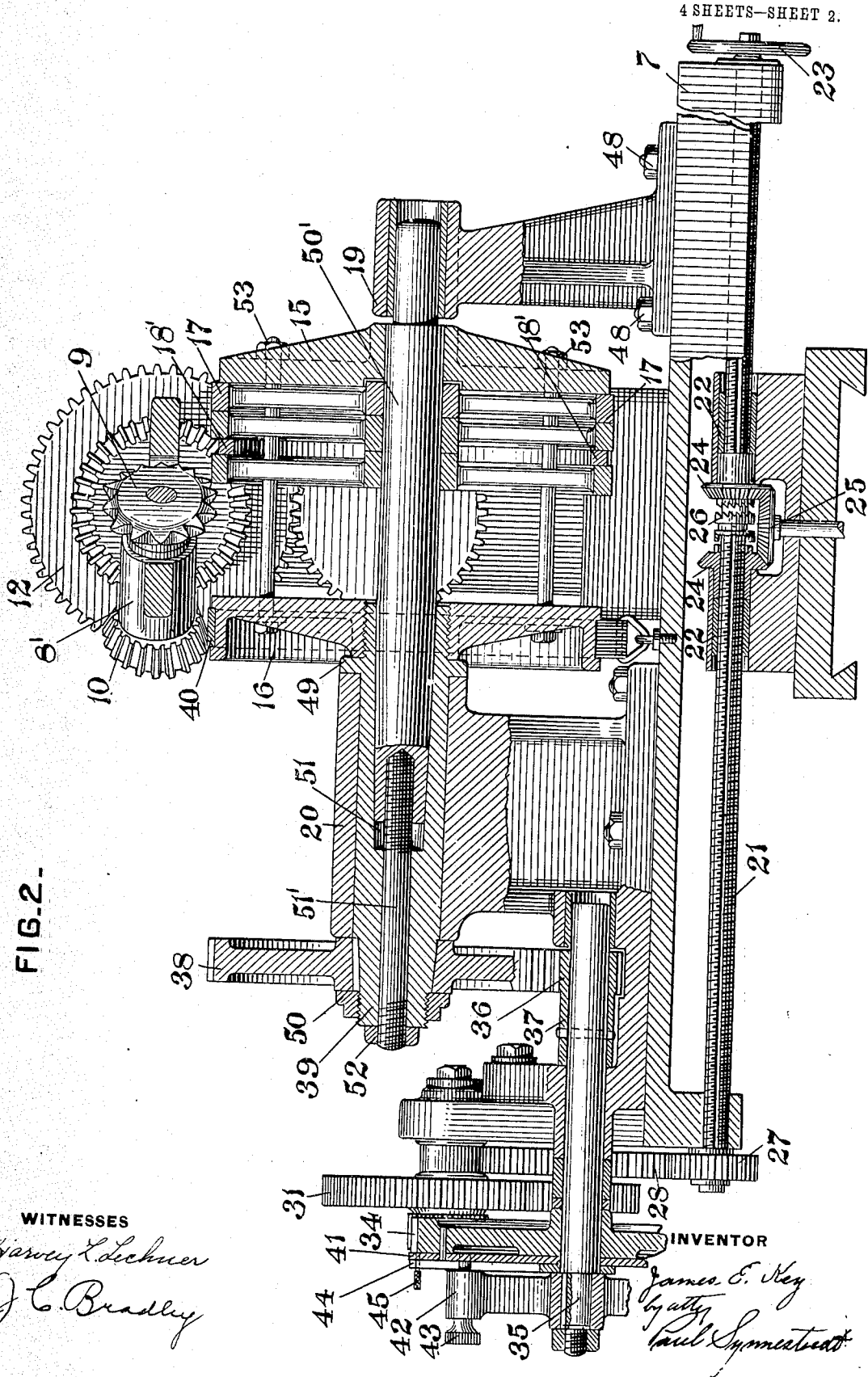

FIG. 2.-

WITNESSES

Harvey L. Lichner
J. C. Bradley

INVENTOR

James E. Key
by atty
Paul Symonds

J. E. KEY.
MILLING MACHINE.

APPLICATION FILED NOV. 13, 1905.

4 SHEETS—SHEET 3.

FIG. 3.

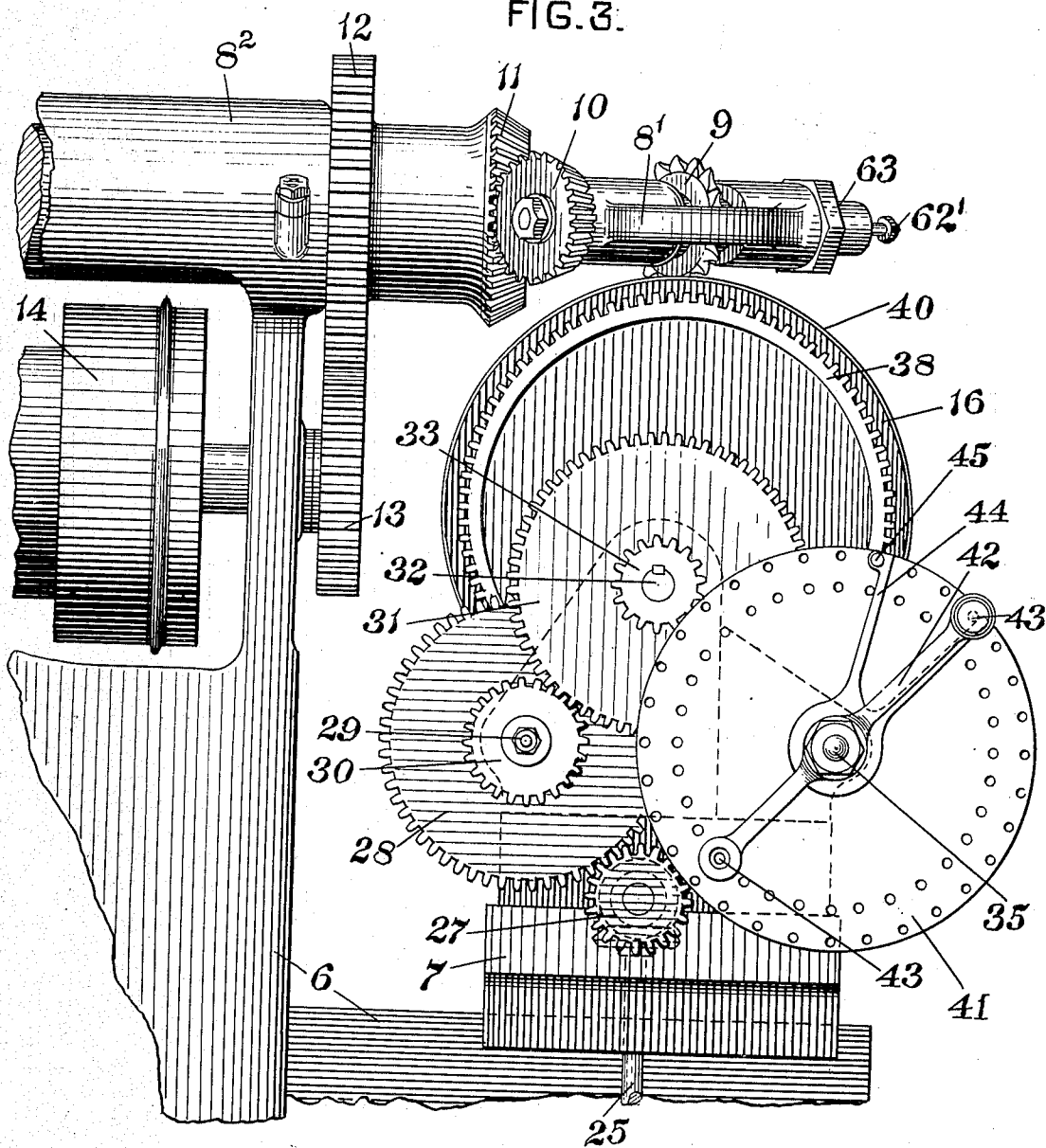

WITNESSES

Norris L. Lechner
J. C. Bradley

INVENTOR

James E. Key
by atty
Paul Symmesworth

J. E. KEY,
MILLING MACHINE.
APPLICATION FILED NOV. 13, 1905.

4 SHEETS—SHEET 4.

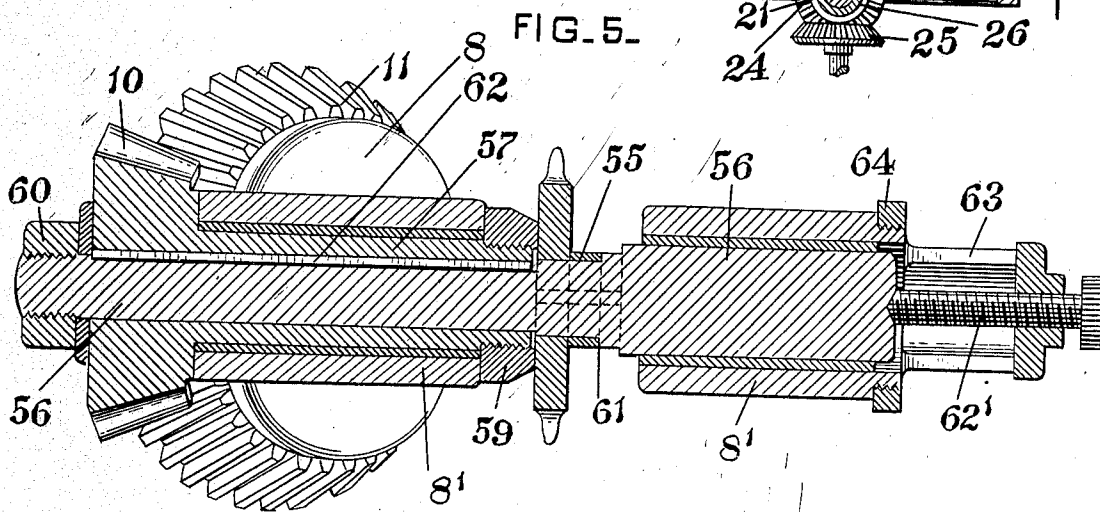
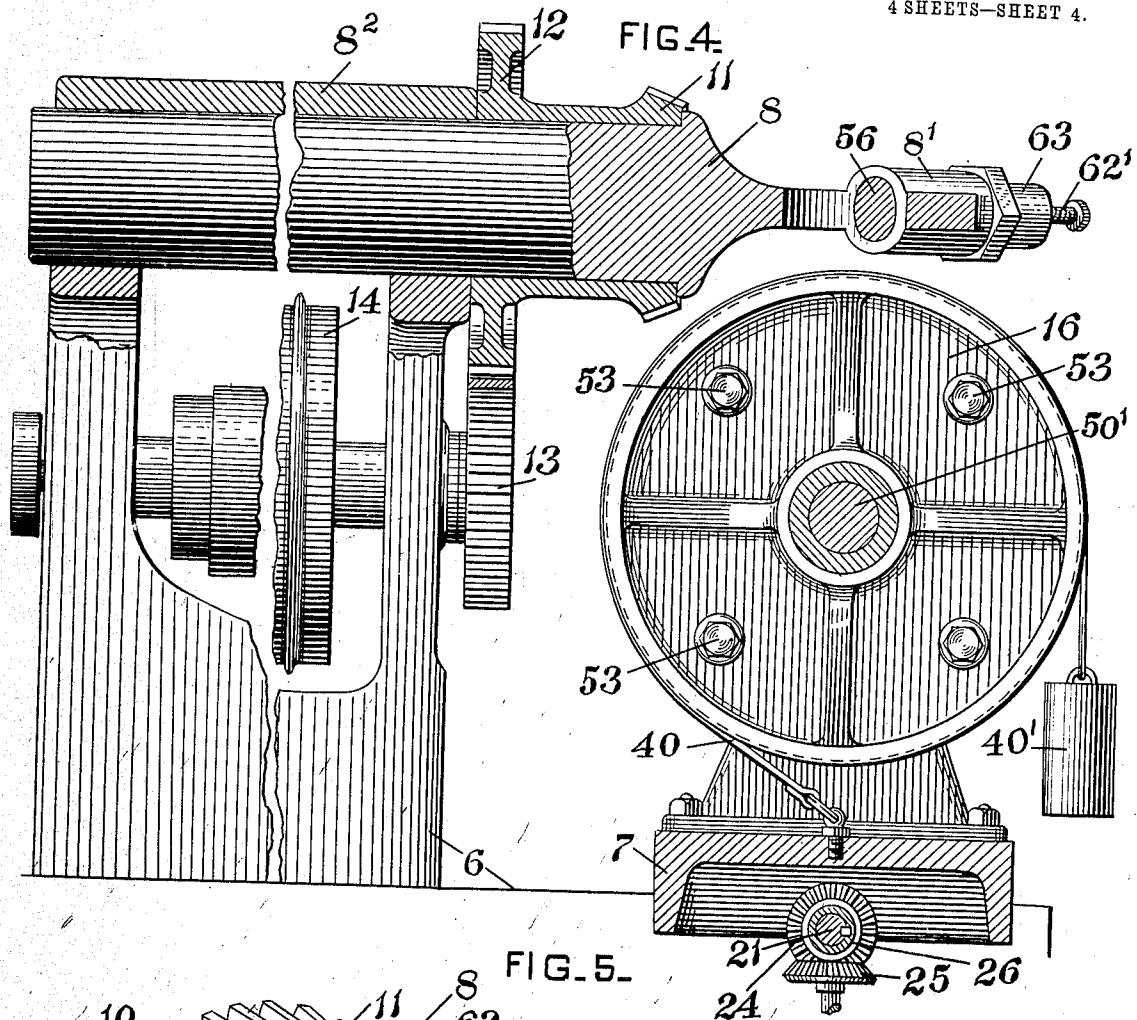

WITNESSES
Narvey L. Dechner
J. C. Bradley

INVENTOR
James E. Key
by *Paul Symmetts*

UNITED STATES PATENT OFFICE.

JAMES E. KEY, OF WILMERDING, PENNSYLVANIA, ASSIGNOR TO THE WESTINGHOUSE AIR BRAKE COMPANY, OF WILMERDING, PENNSYLVANIA, A CORPORATION OF PENNSYLVANIA.

MILLING-MACHINE.

No. 860,218.

Specification of Letters Patent.

Patented July 16, 1907.

Application filed November 13, 1905. Serial No. 237,020.

To all whom it may concern:

Be it known that I, JAMES E. KEY, a citizen of the United States, residing at Wilmerding, in the county of Allegheny and State of Pennsylvania, have invented certain new and useful Improvements in Milling-Machines, of which the following is a specification.

My invention relates to milling machines, and particularly to those for cutting a plurality of blanks simultaneously, in which the cutter is placed at an angle to the work and the work revolves slowly and is given at the same time a right line motion whereby a spiral cut is produced. The objects of the machine are; (1) to provide a machine wherein the angular position of the cutter with reference to the work may be reversed to cut a reverse spiral; (2) to provide a machine in which the rotary and longitudinal feed are so connected that the composite movement is positive and accurate and in which the lost motion in the gearing is taken up; and (3) to provide a machine of this type having an improved means for holding the cutter, whereby such cutter may be replaced without disturbing the driving mechanism. The invention is set forth in the following description and illustrated in the drawings, in which—

Figure 1 is a plan view of the carriage of the machine;

Figure 2 is a cross section through the machine on the line (2) (2) of Figure 1;

Figure 3 is an end elevation of the machine at the left hand end of the device as shown in Figure 2;

Figure 4 is a cross section through the machine on the line (4) of Figure 1, and

Figure 5 is a transverse section through the cutter and its bearings on the line (5) of Figure 1.

The general construction of this machine is of the type in which the work revolves under a milling cutter and is at the same time carried longitudinally on a carriage, whereby a spiral cut is produced on the work. In the present case the articles to be produced are hering-bone gears, and a plurality of blanks are placed in the blank holder and cut at the same operation. Each of the resultant sections forms half of a gear, which half is subsequently matched up with a reverse half cut in the opposite direction on the same machine by turning the cutter upside down and at an opposite angle. It is obvious, however, that the machine might be used to cut single blanks and that the angle might be changed for cutting other styles of gears. The invention resides particularly in the cutter carrying mechanism whereby such mechanism may be reversed to cut gears at opposite angles on the same machine, in the mechanism for producing an accurate composite motion of the blank and taking up back lash, and in the blank and tool holding means and the index mechanism; which are particularly described hereafter.

As shown in the drawings, 6 is the frame of the machine (see Figure 3) over which frame is reciprocally mounted the carriage 7. The frame carries an overhanging arm 8 (Figures 1 and 4) provided with a supporting bearing 8' for the shaft of the cutter 9. The arm 8 is mounted revolvably in a long bearing 8² which is made in two parts and provided with bolts (Figure 3) so that the arm may be clamped thereby. The driving gear for the cutter comprises the gear 10 and the gear 11 carrying on its shank the gear 12, and mounted for revolution on the arm 8. The gear 12 is driven from the gear 13 carried on the shaft of the belt pulley 14. The outer end of the arm 8 which carries the cutter is made symmetrical upon its upper and lower sides, so that the cutter projects an equal amount above and below such arm, and the arrangement is such that the axis of the arm 8 passes through the center of the cutter. It will be seen from this construction that after a set of gears have been cut at the angle shown in Figure 1, another set of gears at the reverse angle may be cut by revolving the arm 8 in its bearing 8² until the cutter is upside down and the gear 10 is on the opposite side of the gear 11. The blank holder is adapted to move transversely under the projecting arm 8 with its cutter, and carries the work between plates 15 and 16. The work consists of the parallel blanks 17 spaced apart in twos by the rings 18 and 18'. As shown, six blanks are cut at a time, but it is evident that this number may be increased or decreased as desired. The blank holder is secured between two bearings 19 and 20, and is adapted to be rotated as the blanks move under the work. The means whereby the carriage is reciprocated and the blanks given a rotary motion constitutes an important feature of the invention and will now be more particularly described, reference being had particularly to Figures 1 and 2. As shown in Figure 2, the carriage is provided with a feed screw 21 held against longitudinal movement with respect to the carriage and feeding through nuts 22 secured to the frame of the machine. This screw is provided at one end with a wheel 23 for hand operation, and also has two gears 24 for operating the feed mechanically. The gears 24 are loose upon the shaft 21 and engage and are driven from the drive gear 25. The gears 24 are adapted to drive the screw 21 in opposite directions by virtue of the clutch 26, which clutch has oppositely engaging toothed faces and is slidingly keyed to the feed screw. Means (not shown) are provided whereby the clutch 26 may be shifted to drive the feed screw 21 in opposite directions. The feed screw not only serves to move the carriage longitudinally, but is also connected with a train of gearing whereby the blank holder is given a motion of rotation under the milling cutter. This train of gearing

consists of a spur wheel 27 secured on the end of the feed screw, a spur wheel 28 on the shaft 29 (Figure 3), a spur wheel 30 on the same shaft, a spur wheel 31 on the shaft 32, a spur wheel 33 on the shaft 32, a spur wheel 34 on the shaft 35, a spur wheel 36 (Figure 1) on the sleeve 37, and a spur wheel 38 on the sleeve 39 (Figure 2), which sleeve is adapted to turn the blank holder. It will be seen that by the use of this positive train of spur gearing the relative longitudinal motion of the carriage and the motion of rotation of the blank is absolutely fixed. The ratio of these two motions may be changed by changing the relative sizes of the gears 27 and 28, or other gears in the train, as desired. In order to take up any lost motion in the gearing a constantly operating friction brake is attached to the blank holder. This brake 40 is passed around the periphery of the end plate 16 (Figures 1 and 4), and consists in the present instance of a friction band fastened at one end to the carriage frame and carrying at the other end a suspended weight 40'.

The indexing mechanism is shown most clearly in Figures 2 and 3. This mechanism is carried upon the shaft 35, which constitutes a part of the connecting gearing between the feed screw and the rotatable blank holder. The index plate 41 is of the usual type and is provided with two sets of peripheral holes for the opposite ends of the index arm 42, and is secured rigidly to the gear 34, which gear is loose on the shaft 35, the index arm 42 is keyed to the shaft 35 and is provided with two spring pins 43 of the usual type, for engaging the holes in the index plate and so forming a connecting link in the train of gearing. The point of novelty in the indexing mechanism resides in the marker 44, which is an arm pivoted coaxially with the index arm, and carries at its outer end a pin 45 which is adapted to engage the holes in the index plate. The purpose of this marking arm is to indicate the position of the index arm at each position, and so render the determination of the next hole more easy. Before the index arm is moved to a new position the marker arm 44 is brought up against it and fixed in position by means of the pin 45. The arm 42 may now be moved without danger of losing track of the starting point. The marker is shown as used with a two-ended index arm 42, but it will be apparent that it is equally applicable to the ordinary index arm which has only one end.

The means for holding the blanks is shown most clearly in Figure 2. As here shown, the side plates 15 and 16 which clamp the blanks between them are rotatably supported from the main bearing 20, and an end bearing 19 which is held at the base by bolts 48, and is adapted to slide on the carriage 7 so that by loosening the bolts 48 the bearing may be slid longitudinally for the removal of the blanks. The main bearing 20 carries the sleeve 39 which sleeve has secured at one end the operating gear 38, and at the other end the end plate 16, which end plate is screwed upon the end of the sleeve. The sleeve is provided with a shoulder 49 which is kept in engagement with the bearing by the holding nut 50 on the outer end of the sleeve. The blanks are carried on a central mandrel 50', which mandrel fits at one end into a tapered recess 51 in the sleeve, and at the other end carries the plate 15 slidably mounted. The man-

drel 50 is held in the tapered recess by the bolt 51' screw threaded at its end and held by the nut 52. The slide plates 15 and 16 may be made to grasp the sides of the blanks by means of the cross bolts 53. When it is desired to remove the finished blanks and replace them by new ones, the bearing 19 is loosened and slid to the right, and the nuts on the bolts 53 are removed and the blanks together with the side plates 15, slipped off endwise. It will be seen that by this arrangement provision is made for removing and replacing blanks with a very slight disarrangement of the mechanism.

Another feature of my invention resides in the means for supporting and removably holding the cutter. This construction is shown in cross section in Figure 5. The supporting bearing 8' is made in two parts. The cutter is mounted upon the shaft 56 and is adapted to operate in the space between the two bearings. The shaft 56 is supported at its right hand end directly by the bearing, but at its left hand end is reduced in diameter and passes through the shank 57 of the gear 10. The shank 57 is held in position by means of the nut 59, which nut is adapted to bear against the cutter. The shaft 56 is screw-threaded at its left hand end and is held in position by the nut 60. The shaft 56 is shouldered at 61 and provided with a key way 62. The shoulder 61 is adapted to hold the cutter against the nut 59 and is held tightly in engagement therewith by the screw 62', which screw is mounted in a yoke 63 screwed at 64 to the end of the bearing. In order to make provision for using a plurality of cutters a spacing ring 55 may be used between the shoulder and the cutter. It will be seen from the above construction that by removing the nuts 60, loosening the screw 62' and unscrewing the yoke 63 the shaft 56 may be withdrawn bodily to the right, and at the same time leave the gearing intact.

The operation of the device is as follows: The side plate 15 and bearing 19 having been removed to the right, and a plurality of blanks with their space rings having been placed upon the mandrel 50', the side plate 15 and bearing 19 are moved into place and secured tightly by the bolts 53 and 48. By means of the hand wheel 23 the carriage is moved to the proper position at which to commence the cut. The clutch 26 is then thrown into operation. The rotation of the feed screw 21 carries the carriage past the feed nuts 22, and through the train of gearing 27, 28, 30, 31, 33, 34, 36 and 38, slowly revolves the blank carrier. The combined longitudinal and rotary motion of the blanks carries the work in a spiral direction relative to the cutter, and cuts a groove as shown in Figure 1. The clutch 26 is now thrown to the other position and the machine reversed, thereby carrying the cutter back to its starting position. The marker is now moved along the requisite distance for spacing a new cut and the operation repeated. When it is desired to produce the reverse halves of these gears the arm 8 is simply loosened in its clamp bearing 8², turned to bring the cutter upside down and the gear 10 on the opposite side of the gear 11, the clamp bearing 8² is tightened and the operation proceeds as before.

Having thus described my invention and illustrated its use, what I claim as new and desire to secure by Letters Patent, is the following.

1. In combination in a milling machine, a carriage, a rotatable blank holder mounted thereon, a revoluble cutter

supporting member with its axis in a different plane from that of the axis of the blank holder but parallel thereto, a cutter shaft lying in the plane of the axis of the cutter supporting member and mounted upon the supporting member oblique to both the axis of the blank holder and to the axis of the cutter supporting member and a cutter mounted thereon.

2. In combination in a milling machine, a carriage, a rotatable blank holder mounted thereon, a revoluble cutter supporting member with its axis extending across the axis of the blank holder in a plane parallel to the plane of the axis of the blank holder, a cutter shaft lying in the plane of the axis of the cutter supporting member and mounted upon the supporting member oblique to the axis of the cutter supporting member and a cutter mounted thereon in line with the axis of the cutter supporting member.

3. In combination in a milling machine, a carriage, a rotatable blank holder mounted thereon, a revoluble cutter supporting member with its axis in a different plane from that of the axis of the blank holder but parallel thereto, a cutter shaft lying in the plane of the axis of the cutter supporting member and mounted upon the supporting member oblique both to the axis of the blank holder and to the axis of the cutter supporting member and having a cutter mounted thereon and a driving means for the cutter shaft comprising a bevel gear on such shaft meshing with a bevel gear mounted coaxial with the axis of the supporting member.

4. In combination, a two-part bearing, a cutter lying between such parts and provided with an opening, a shaft carried at its ends by the bearings and of such a size for a portion of its length that the cutter may slide thereon, a driving gear provided with a shank which fits over the shaft and lies inside one part of the bearing and having a part at its end for engaging the cutter, means for holding the sleeve from longitudinal movement and means for holding the shaft from longitudinal movement.

5. In combination, a divided bearing with a space between the parts, a cutter lying in such space and having an axial shaft opening, a shaft engaging the bearing and provided with a shoulder for holding the cutter longitudinally and being of such size from the shoulder to the end that the cutter may slide thereover, a gear provided with a shank which fits over the reduced portion of the shaft inside one of the bearings and provided with holding

means bearing against the cutter, and means for holding the shaft longitudinally with its shoulder clamping the cutter.

6. In combination, a divided bearing with a space between the parts, a cutter lying in such space and having an axial shaft opening, a shaft engaging the bearing and provided with a shoulder against which the cutter is adapted to bear and being of such size from the shoulder to the end that the cutter may slide thereover, a driving gear provided with a shank which fits over the reduced portion of the shaft inside one of the bearings and provided with a screw threaded portion at such bearing end, a nut therefor, a support on the other bearing and a screw thereon adapted to bear against the end of the shaft and holding the shoulder on such shaft against the nut on the sleeve.

7. In combination a recessed bearing, a shaft adapted to move transversely therethrough and provided with a shoulder and reduced portion, a cutter adapted to slide over the reduced portion of the shaft and rest against the shoulder, means on one of the bearings for engaging one end of the shaft, a gear on the other end of the shaft provided with a shank fitting between the end of the shaft and its bearing and provided with holding means on the end toward the cutter for preventing movement away from the cutter.

8. In combination, a divided bearing with a space between the parts, a cutter lying in such space and having an axial shaft opening, a shaft engaging the bearing and provided with a shoulder for holding the cutter longitudinally and being of such size from the shoulder to the end that the cutter may slide thereover, a driving gear provided with a shank which fits over the reduced portion of the shaft inside one of the bearings and provided with a screw threaded portion at such bearing end, a nut therefor, a yoke screw threaded on the other bearing and a screw thereon adapted to bear against the end of the shaft and hold the shoulder on such shaft so as to clamp the cutter against the nut.

In testimony whereof I have hereunto signed my name in the presence of the two subscribed witnesses.

JAMES E. KEY.

Witnesses:

R. F. EMERY,
J. B. MACDONALD.