

C. H. COX.
 CAR-AXLE BOX.

No. 174,341.

Patented Feb. 29, 1876.

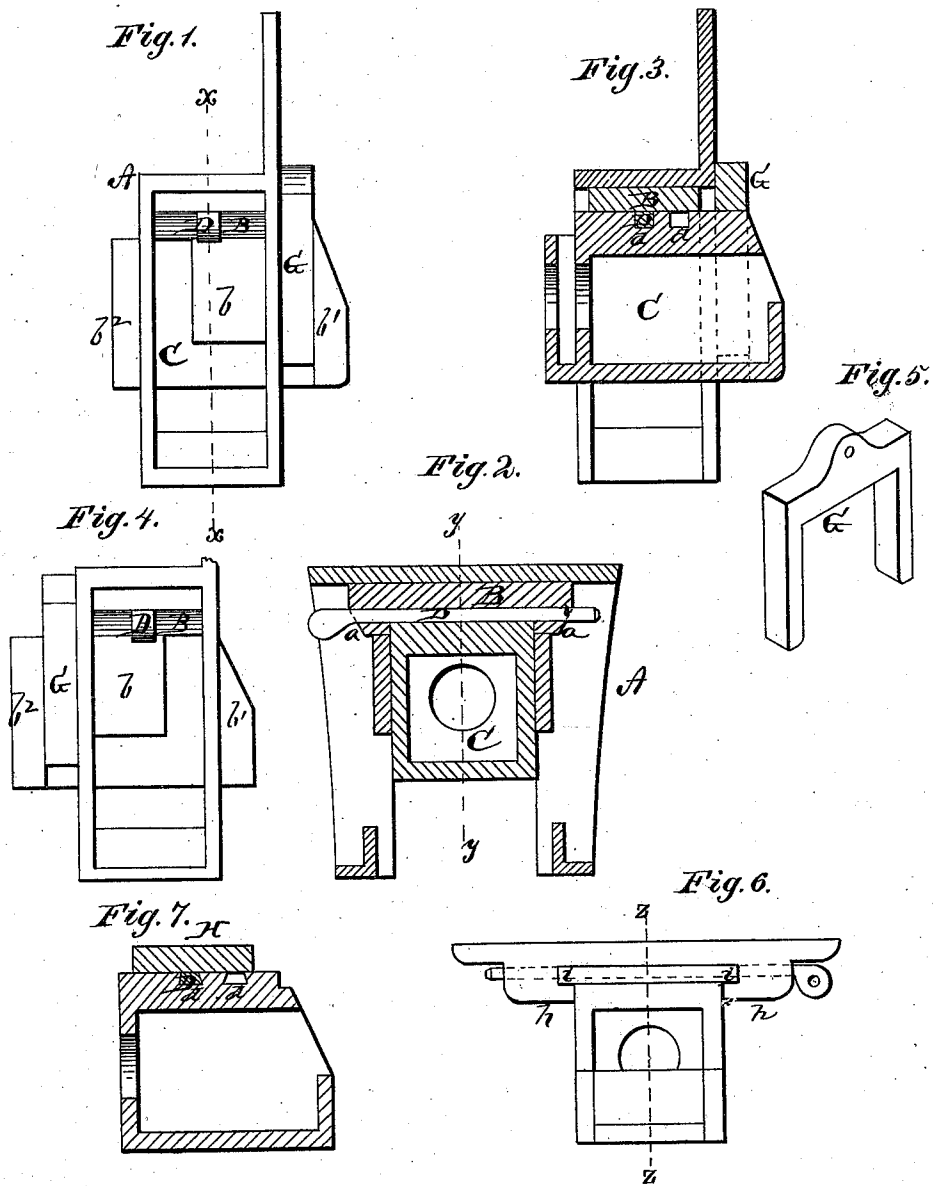

WITNESSES

Henry N. Miller
 C. L. Ewert

B11

INVENTOR

Chas. H. Cox.
 Alexander Mason
 Attorneys.

UNITED STATES PATENT OFFICE.

CHARLES H. COX, OF RICHMOND, ASSIGNOR TO JOHN STEWART, OF
HENRICO COUNTY, VIRGINIA.

IMPROVEMENT IN CAR-AXLE BOXES.

Specification forming part of Letters Patent No. 174,341, dated February 29, 1876; application filed
November 18, 1875.

To all whom it may concern :

Be it known that I, CHARLES H. COX, of Richmond, in the county of Henrico and in the State of Virginia, have invented certain new and useful Improvements in Car-Axle Journal-Boxes; and do hereby declare that the following is a full, clear, and exact description thereof, reference being had to the accompanying drawings, and to the letters of reference marked thereon, making a part of this specification.

My invention relates to car axle journal-boxes, and consists in the construction and arrangement of devices whereby the box may be adjusted out and in, so as to adapt the car-truck to broad or narrow gage, as will be hereinafter more fully set forth.

In order to enable others skilled in the art to which my invention appertains to make and use the same, I will now proceed to describe its construction and operation, referring to the annexed drawing, in which—

Figure 1 is a side elevation, showing the box arranged for wide gage. Fig. 2 is a vertical section of the same through the line *x x*, Fig. 1. Fig. 3 is a vertical section of the same through the line *y y*, Fig. 2. Fig. 4 is a side elevation of the box, showing it arranged for narrow gage. Fig. 5 is a perspective view of the clevis-key used therewith. Figs. 6 and 7 show modifications of the same.

A represents the ordinary pedestal as used on passenger-cars. In this pedestal is a slide, B, on top of the journal box C, said slide having on its under side near each end a flange, *a*, which fits on the side of the box. The journal-box C is on each side formed with a center projection, *b*, and vertical front and rear flanges *b¹ b²*, which leave two wide grooves, one on each side of the center projection, for the legs of the pedestal to work in. In the top of the box C are made two cross-grooves, *d d*, for the passage of a pin, D, which passes through holes in the flanges *a* of the slide B, to hold the box from moving endwise in the pedestal. By changing the pin D from one groove to the other, the box

may be moved out or in, so as to adapt the truck either to a broad or narrow track, as may be desired. G represents a clevis, constructed as shown in Fig. 4, and used by straddling the box either on the outer or inner side of the pedestal, according to the position of the box for broad or narrow gage, the legs of the clevis passing down between the pedestal and either of the front or rear flanges *b¹ b²* on the sides of the journal-box. This clevis G may be used either in place of the pin D or in connection therewith, as desired.

For freight-cars, the pedestal H, as shown in Figs. 6 and 7, has hook-shaped flanges *h h* at the ends, for holding the projecting flanges *i i* on the sides of the journal-box at the top, and the top of the box is grooved in the same manner for the insertion of the pin D. By these means the journal-box can easily and quickly be moved or changed out or in, so as to adapt the truck to broad or narrow gage track, as required.

Having thus fully described my invention, what I claim as new and desire to secure by Letters Patent, is—

1. The combination, with a car-truck pedestal, A, of the slide B, having flanges *a a*, the journal-box C, having grooves *d d* in its upper surface, and the pin D, substantially as and for the purposes herein set forth.

2. The combination, with a car-truck pedestal, A, of the journal-box C, provided with side flanges or projections *b b¹ b²*, and the clevis G, substantially as and for the purposes herein set forth.

3. The combination of the pedestal H, having hooked end flanges *h h*, the journal-box C, having grooves *d d* in its upper surface, and side flanges *i i*, and the pin D, substantially as and for the purposes herein set forth.

In testimony that I claim the foregoing I have hereunto set my hand this 14th day of October, 1875.

CHARLES H. COX.

Witnesses:

JOS. BRYAN,
J. B. STEWART.