

(No Model.)

W. ANDERSON.  
HOLDBACK STRAP.

No. 438,747.

Patented Oct. 21, 1890.

Fig. 1.

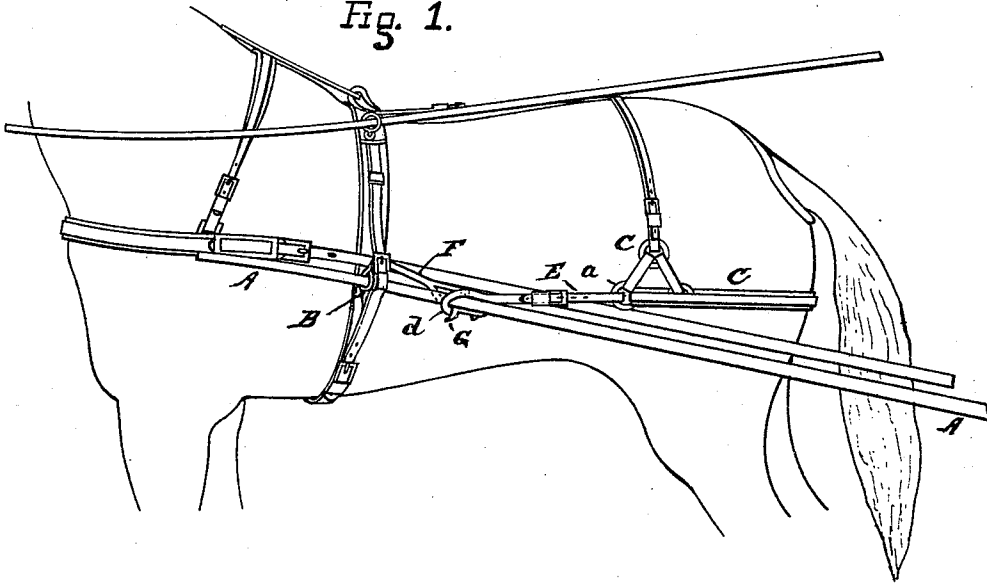

Fig. 2.

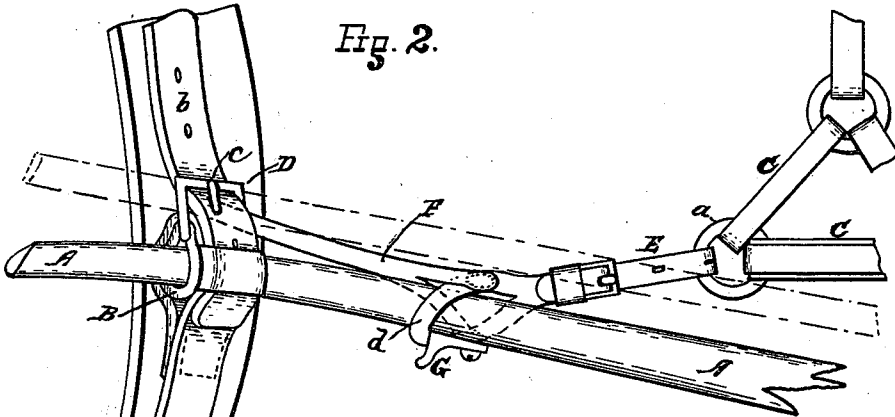

Fig. 3.

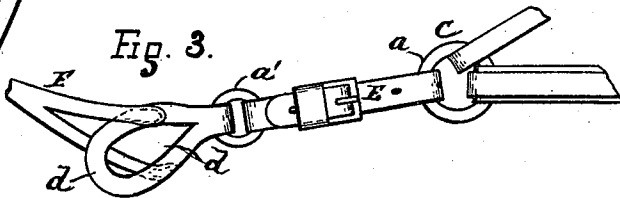
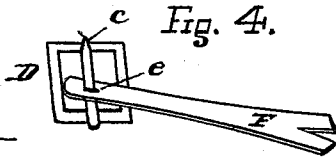

Fig. 4.



WITNESSES:

*J. P. Orolough*  
*G. M. Slight*

INVENTOR.

*Willie Anderson*  
BY *F. F. Warner*  
his ATTORNEY.

# UNITED STATES PATENT OFFICE.

WILLIS ANDERSON, OF MAGEE'S CORNERS, NEW YORK.

## HOLDBACK-STRAP.

SPECIFICATION forming part of Letters Patent No. 438,747, dated October 21, 1890.

Application filed July 16, 1890. Serial No. 358,877. (No model.)

*To all whom it may concern:*

Be it known that I, WILLIS ANDERSON, a citizen of the United States, and a resident of Magee's Corners, in the county of Seneca and State of New York, have invented certain new and useful Improvements in Holdbacks for Harness, of which the following is a specification.

My invention relates to that part of a harness usually known as the "holdback" or "holdback-straps."

The purpose of my improvement is to provide simple means whereby the carriage may be effectually prevented from running upon or interfering with the horse, and also to facilitate the act of unhitching the horse and detaching the harness from the thills. I attain these objects by the means hereinafter described, and illustrated in the accompanying drawings, in which—

Figure 1 is a side view of a harness embodying my improvements, showing the same as they appear when applied to use. Fig. 2 is a like representation, enlarged, and showing only so many of the parts shown in Fig. 1 as are necessary to more clearly illustrate my invention. Fig. 3 is a detail showing a modification of the construction shown in Fig. 2, and Fig. 4 is a detail more clearly showing the manner of connecting my holdback to a buckle forming a part of the saddle-girth.

Like letters of reference indicate like parts.

In the drawings, A represents the carriage-shaft, and B is the shaft-tug, usually employed for supporting the shafts near their front ends.

C is the breeching, in the lower or forward parts of which there is usually a ring *a*.

D is a buckle, usually employed for connecting the tug B to a strap *b*, attached to the saddle-skirts, and *c* is the tongue of this buckle.

So far as thus described the parts of the harness to which I referred are all old and well known, and it is unnecessary for me to describe the same more fully or to refer to other parts for the purpose of explaining my invention, as will hereinafter more fully appear.

E, as shown in Figs. 1 and 2, is a strap made by preference in one and the same piece and

buckled or otherwise extensibly connected to or buckled in the ring *a*. The forward or lower end is made open or in the form of a loop of such size as to permit the thill or shaft to be thrust into it easily, as indicated at *d*.

F is a strap forked at one end by preference, and having its forked ends stitched or otherwise attached to the loop *d*, as represented. The other or forward end of the strap F has in it a slit, slot, or hole *e* and is connected to the buckle D by passing the tongue *c* of the said buckle through the said hole, as is clearly indicated in Fig. 4.

In making an entirely new harness embodying my invention I prefer to make the strap E and its loop in one and the same piece of leather, as represented in Figs. 1 and 2; but in making my improvements for attachment to old harnesses I provide the upper or rear end of the loop *d* with a ring *a'*, (shown in Fig. 3,) into which the holdback-strap forming a part of such harness may be buckled. It will now be perceived that the strap E (shown in Figs. 1 and 2) is essentially the same as the strap shown in Fig. 3, excepting that the latter is connected to its loop by means of a ring or link instead of being continuous or in one and the same piece with the loop.

G is a metallic plate or lug securely attached to the under side of the shafts in any suitable way and arranged about where the holdback-loop is usually applied. This lug, as will be perceived, prevents the loop *d* from slipping back upon the thills, or, in other words, it, in connection with the holdback-straps and breeching, prevents the carriage from running upon the horse. It will also be observed that the loop *d* by being connected by means of the strap F to the girth-band admits of the loop *d* and the holdback being drawn with facility from the thills when the rest of the harness is removed. It will also be noticed that the holdback is applied ready for use simply by thrusting the thills through the loops *d d*, it being understood that there is such a loop upon each side of the harness.

I am aware that holdback-straps have heretofore been connected more or less directly to the thill tugs or supports and that the lat-

ter have borne against stops applied to the  
thills immediately behind the said tugs, and  
I do not therefore here intend to claim the  
same; but

5 What I claim as new, and desire to secure  
by Letters Patent, is—

The strap E, having in one end a loop or  
opening *d*, and the strap F, attached at one

end to the said loop, the whole constituting a  
holdback attachment substantially such as is  
specified.

WILLIS ANDERSON.

Witnesses:

E. A. STORY,  
L. R. ANDERSON.