

(19) World Intellectual Property Organization
International Bureau



(43) International Publication Date
31 January 2008 (31.01.2008)

PCT

(10) International Publication Number
WO 2008/013594 A2

(51) International Patent Classification:
A43B 13/20 (2006.01)

(21) International Application Number:

PCT/US2007/011976

(22) International Filing Date: 18 May 2007 (18.05.2007)

(25) Filing Language: English

(26) Publication Language: English

(30) Priority Data:

60/801,381	19 May 2006 (19.05.2006)	US
60/802,103	22 May 2006 (22.05.2006)	US
60/802,779	24 May 2006 (24.05.2006)	US
60/808,819	26 May 2006 (26.05.2006)	US

(71) Applicant and

(72) Inventor: ELLIS, Frampton, E. [US/US]; P.o. Box 1029,
Jasper, FL 32052 (US).

(74) Agent: GARRETT, Arthur, S.; Finnegan, Henderson,
Farabow, Garrett & Dunner Llp, 901 New York Avenue,
Nw, Washington, DC 20001-4413 (US).

(81) Designated States (unless otherwise indicated, for every kind of national protection available): AE, AG, AL, AM, AT, AU, AZ, BA, BB, BG, BH, BR, BW, BY, BZ, CA, CH, CN, CO, CR, CU, CZ, DE, DK, DM, DZ, EC, EE, EG, ES, FI, GB, GD, GE, GH, GM, GT, HN, HR, HU, ID, IL, IN, IS, JP, KE, KG, KM, KN, KP, KR, KZ, LA, LC, LK, LR, LS, LT, LU, LY, MA, MD, ME, MG, MK, MN, MW, MX, MY, MZ, NA, NG, NI, NO, NZ, OM, PG, PH, PL, PT, RO, RS, RU, SC, SD, SE, SG, SK, SL, SM, SV, SY, TJ, TM, TN, TR, TT, TZ, UA, UG, US, UZ, VC, VN, ZA, ZM, ZW.

(84) Designated States (unless otherwise indicated, for every kind of regional protection available): ARIPO (BW, GH, GM, KE, LS, MW, MZ, NA, SD, SL, SZ, TZ, UG, ZM, ZW), Eurasian (AM, AZ, BY, KG, KZ, MD, RU, TJ, TM), European (AT, BE, BG, CH, CY, CZ, DE, DK, EE, ES, FI, FR, GB, GR, HU, IE, IS, IT, LT, LU, LV, MC, MT, NL, PL, PT, RO, SE, SI, SK, TR), OAPI (BF, BJ, CF, CG, CI, CM, GA, GN, GQ, GW, ML, MR, NE, SN, TD, TG).

Published:

— without international search report and to be republished upon receipt of that report

For two-letter codes and other abbreviations, refer to the "Guidance Notes on Codes and Abbreviations" appearing at the beginning of each regular issue of the PCT Gazette.

(54) Title: DEVICES WITH INTERNAL FLEXIBILITY SIPES, INCLUDING SIPED CHAMBERS FOR FOOTWEAR

(57) Abstract: Devices with internal flexibility sipes, such as slits, provide improved flexibility, improved cushioning to absorb shock and/or shear forces, and improved stability of support. Siped devices can be used in any existing product that provides or utilizes cushioning and stability. These products include human and other footwear, both soles and uppers, as well as orthotics; athletic, occupational and medical equipment and apparel; padding or cushioning, such as for equipment or tool handles, as well as furniture; balls; tires; and any other structural or support elements in a mechanical, architectural, or any other product.



WO 2008/013594 A2

**DEVICES WITH INTERNAL FLEXIBILITY SIPES,
INCLUDING SIPED CHAMBERS FOR FOOTWEAR**

BACKGROUND OF THE INVENTION

1. Field of the Invention

The invention relates to all forms of footwear, including street and athletic, as well as any other products benefiting from increased flexibility, better resistance to shock and shear forces, and more stable support. More particularly, the invention incorporates devices as a unitary integral insert or component with at least one internal (or mostly internal) sipe, including slits or channels or grooves and any other shape, including geometrically regular or non-regular, such as anthropomorphic (or animal) shapes, into a large variety of products including footwear using materials known in the art or their current or future equivalent, as well as materials that are very firm compared to those taught in the art.

Still more particularly, the unitary internal sipe insert or component provides improved flexibility to products utilizing them, as well as improved cushioning to absorb shock and/or shear forces, including through the use of firm materials, while also improving stability of support, and therefore the siped devices can be used in any existing product that provides or utilizes cushioning and stability. These products include human and other footwear, both soles and uppers, and orthotics; athletic, occupational and medical equipment and apparel; padding or cushioning, such as for equipment or tool handles and furniture; balls; tires; and any other structural or support elements in a mechanical, architectural or any other device. Still more particularly, the integral insert or component with at least one sipe, including in the form of a slit, can include a media such as a lubricant or glue of any useful characteristic such as viscosity or any material, including a magnetorheological fluid.

The invention further relates to at least one chamber or compartment or bladder surrounded, partially or completely, by at least one internal (or mostly internal) sipe, including at least partially in the form of a slit, for use in any footwear soles or uppers, or orthotic soles or uppers, including the use of firm materials, and for other flexibility,

cushioning, and support uses in athletic equipment like helmets and apparel including protective padding and guards, as well as medical protective equipment and apparel, and other uses, such as protective flooring, improved furniture cushioning, balls and tires for wheels, and many other uses.

The internal sipe integral insert or component invention further can be usefully combined with the applicant's prior footwear inventions described in this application and expressly incorporated by reference herein below, including removable midsole structures and orthotics and chambers with controlled variable pressure, including control by computer, for example.

2. Brief Description of the Prior Art

Existing devices are generally much less flexible than would be optimal, especially products for human (or animal or other biological-based) users, whose non-skeletal anatomical structures like bare foot soles generally remain flexible even when made hard by significant pressure caused by body weight, whereas the products interfacing directly with them are often much more rigid.

Taking footwear soles as one example, cushioning elements like gas bladders or chambers or compartments are typically fixed directly in other midsole foam plastic material to form a structure that is much more rigid than the sole of the human wearer's bare foot, which is relatively soft when unloaded and hard but still flexible when loaded under body weight. As a result, the support and cushioning of the bare foot are seriously degraded when shod in existing footwear, since the relatively rigid shoe sole drastically alters by obstructing the way in which the bare foot would otherwise interact with the ground underneath a wearer. The effective natural interface is replaced by an inferior artificial one.

The use of open or external traction sipes -- that is, sipes in the form of slits or channels that typically are substantially vertical and open to an outside surface, particularly a ground-contracting surface -- to provide also flexibility in footwear soles has been fully described by the applicant in prior applications, including the examples shown in Figures 55A-55C, 56, 57, and 73A-73D of both the applicant's prior

footwear U.S. Patent Application No. 11/190,087, published as Pub. No. 2005/0268487 A1 on December 8, 2005, and the applicant's prior orthotic U.S. Patent No. 7,010,869, issued March 14, 2006, (as well as continuation U.S. Application No. 11/108,034, published as Pub. No. 2005/0217142 A1 on October 6, 2005), and in Figures 35-40 of U.S. Patent Application 11/179,887, published as Pub. No. US2005/0241183 on November 3, 2005, all of which foregoing U.S. patents and published applications are herein incorporated by reference for completeness of disclosure.

The applicant first described such non-traction oriented open external sipes in footwear in PCT Application PCT/US90/06028 titled "Shoe Sole Structures Which Are Siped to Provide Natural Deformation Paralleling the Foot" filed 19 October 1990 and published by WIPO as Int. Pub. No. WO 91/05491 on 2 May 1991. Such open external sipes principally provide flexibility to the footwear sole by providing the capability of the opposing surfaces of the sipe to separate easily from each other. However, external sipes are structurally unlike natural anatomical structures (since to be effective, they must be much deeper than surface skin texture like finger prints, the closest anatomical analogy).

Also, external sipes tend to introduce significant instability by creating excessive edge weakness in the shoe sole adjacent the sipes, just like a paperback book being unable to support weight when standing on end with the pages vertical, but stable when the book and pages are lying flat. External sipes by being open also collect debris in the sipes, seriously reducing sipe performance. In addition, the most optimal pattern and depth of such sipes is unknown and therefore difficult to ascertain directly, except as an error-prone trial and error process guided by second-guessing nature, since deep, open sipes are obviously not used in the design of the human foot. Moreover, the only way to get relatively seamless, continuous natural flexibility like the human foot sole using external sipes is to introduce a very large number of deep sipes on as many different axis as possible in the shoe sole, which produces an impractically soft and unstable shoe sole, the use of which would be roughly like trying to stand on the edge of a large urban area telephone book.

Instead, a much more reasonable and fool-proof procedure is to

follow as closely as practical the natural design of the human anatomical foot sole structure with which it is intended to interface to create the closest-to-natural flexibility.

The use of a integral component with internal sipes in footwear soles like those described in this application overcome the problems of external sipes noted above and are naturally more optimal as well, since they more closely parallel structurally the natural anatomical structures of the wearer's bare foot sole. As one example, simply enveloping the outer surface of existing cushioning devices like gas bladders or foamed plastic Ethyl Vinyl Acetate (EVA) or Polyurethane (PU) with a new outer layer of material that is unattached (or at least partially unattached) thereby can creates if unglued an internal sipe between the inner surface of the new compartment and the outer surface of the existing bladder/midsole component, allowing the two surfaces to move relative to each other rather than being fixed to each other.

Especially in the common form of a slit structure seen in many example embodiments, the flexibility of the internal sipe is provided by this relative motion between opposing surfaces that in many the example embodiments are fully in contact with each other, again in contrast to the separating surfaces of external sipes; such surface contact is, of course, exclusive of any internal sipe media, which can be used as an additional enhancement, in contrast to the flexibility-obstructing debris unavoidably picked up by, and often clogging, open external sipes. As a result, the footwear sole in which at least one integral internal sipe insert or component is incorporated becomes much more flexible, much more like the wearer's bare foot sole itself, so that foot sole can interact with the ground naturally. The resulting footwear sole with internal sipes has improved, natural flexibility, improved cushioning from shock and shear forces, and better, more naturally stable support.

A limited use of internal sipes has also been described by the applicant in prior applications, including the examples shown in Figures 12A-12D, 60A-60E, and 70-71 of both the applicant's '087 and '034 published Applications and '869 Patent herein incorporated by reference above, which are generally unglued portions coinciding with lamination layer boundaries, such as between bottomsole and midsole layers. This

older approach requires completely new and somewhat difficult approaches in the assembly of the footwear sole during manufacture, as well as significantly greater potential for problems of layer separation (especially bottom sole) since the inherent reduction in gluing surfaces makes the remaining gluing surfaces critical and under increased load; significantly increased positional accuracy in the application of glue is required. Also, the use of lubricating media (and the potential control thereof, including by microprocessor) is also more difficult, since the sipe is formed by existing parts and is not discretely enclosed with the new outer layer to contain the media, as it is in a new invention described in this application.

In contrast, a new invention of this application is a discrete device in the form of an integral component that can easily be inserted as a single simple step into the footwear sole during the manufacturing process or, alternatively, inserted in one single simple step by a wearer (into the upper portion of a midsole insert, for example, much like inserting an insole into an shoe), for whom the new extra layer provides buffering protection for the wearer from direct, potentially abrasive contact with a cushioning component (forming a portion of the inner, foot sole-contacting surface of the shoe sole, for example).

In addition, such a new invention allows easier and more effective containment of a lubricating media (including media with special capabilities, like magnetorheological fluid) within the integral internal sipe, so that the relative motion between inner surfaces of the sipe can be controlled by that media (and, alternatively, by direct computer control); it avoids the need for the use of closed-cell midsole materials or a special impermeable layer applied to the footwear sole material to prevent the sipe media from leaking away.

The new invention also makes manufacturing easier and inherently more accurate, since the introduction of the fluid media can be better control during a separate process when the separate unitary insert or component 510/511/513 is manufactured by itself, rather than attempting to integrate that process into the already complex sole or orthotic molding and assembly process.

Accordingly, it is a general object of one or more embodiments of

the invention to elaborate upon the application of the use of a device in the form of an insertable integral component with one or more internal sipes to improve the flexibility, cushioning, and stability of footwear and other products.

It is still another object of one or more embodiments of the invention to provide footwear having an integral insert or component with at least one internal (or mostly internal) sipes, including slits or channels or grooves and any other shape, including geometrically regular or non-regular, such as anthropomorphic or animal shapes, to improve flexibility, cushioning and stability.

It is still another object of one or more embodiments of the invention to include an insertable integral device with one or more internal sipes that include a media such as a lubricant or glue of any useful characteristic such as viscosity or any material, including a magnetorheological fluid.

It is another object of one or more embodiments of the invention to create a shoe sole with flexibility, support and cushioning that is provided by siped chambers or compartments or bladders in the footwear sole or upper or orthotics. The compartments or chambers or bladders are surrounded, partially or completely, by at least one internal (or mostly internal) sipe, including in the form of a slit, for use in any footwear soles or uppers, or orthotic soles or uppers, and for other flexibility, cushioning, and stability uses in athletic equipment like helmets and apparel including protective padding and guards, as well as medical protective equipment and apparel, and other uses, such as protective flooring, improved furniture cushioning, balls and tires for wheels, and many other uses.

It is another object of one or more embodiments of the invention to create footwear, orthotic or other products with at least one outer chamber; at least one inner chamber inside the outer chamber; the outer chamber and the inner chamber being separated at least in part by an internal sipe, including in the form of a slit; at least a portion of an inner surface of the outer chamber forming at least a portion of an inner surface of the internal sipe; and the internal sipe providing increased flexibility, cushioning, and stability for the footwear, orthotic or other

product.

A further object of one or more embodiments of the invention is to combine the integral insert or component with at least one internal sipe with the applicant's prior footwear inventions described and herein incorporated by reference in this application, including removable midsole structures and orthotics and chambers with controlled variable pressure, including control by computer.

These and other objects of the invention will become apparent from the summary and detailed description of the invention, which follow, taken with the accompanying drawings.

SUMMARY OF THE INVENTION

In one aspect the present invention attempts, as closely as possible, to replicate and interface with the naturally effective structures of the bare foot that provide flexibility, cushioning, and stable support. More specifically, the invention relates to a device for a footwear sole or upper or both, or an orthotic or orthotic upper or both, or other, non-footwear devices, including a unitary internal sipe insert or component, said internal sipe providing increased flexibility for said device. More specifically, the invention relates to an integral insert or component with at least one slit with a media such as a lubricant or glue of any useful characteristic such as viscosity or any material, including a magnetorheological fluid.

Even more specifically, the invention relates to footwear or orthotics or other products with at least one compartment or chamber or bladder surrounded, partially or completely, by at least one internal (or mostly internal) sipe, including in the form of a slit, for use in any footwear soles or uppers, or orthotic soles or uppers, and for other flexibility, cushioning, and stability uses. Even more specifically, the invention relates to footwear, orthotic or other products with at least one outer chamber; at least one inner chamber inside the outer chamber; the outer chamber and the inner chamber being separated at least in part by an internal sipe, including in the form of a slit; at least a portion of an inner surface of the outer chamber forming at least a portion of a surface of the internal sipe; and the internal sipe providing increased

flexibility, cushioning, and stability for the footwear, orthotic or other product.

These and other features of the invention will become apparent from the detailed description of the invention that follows.

BRIEF DESCRIPTION OF THE DRAWINGS

Figures 1-44 of this application are Figures 83-127 of both the applicant's U.S. Application 11/282,665 filed November 21, 2005 and published on November 9, 2006 as Pub. No. US 2006/0248749 A1 and PCT Application PCT/US2005/042341 filed 21 November 2005 and published on 1 June 2006 as Int. Pub. No. WO 2006/058013 A2, both of which are incorporated herein by reference.

Fig. 1A-4A show a frontal or sagittal plane cross section view of an example of a device 510 such as a flexible insert with a siped compartment or chamber or bladder.

Figs. 1B-6B shows a horizontal plane view of a device 510 example.

Figs. 5A-6A show a frontal or sagittal plane cross section view of an example of a device 510 such as a flexible insert with two siped compartments or chambers or bladders or combination.

Fig. 7 shows, in a frontal plane cross section in the heel area, a shoe and shoe sole including a single siped compartment 510.

Fig. 8 shows a similar embodiment and view to that shown in Fig. 7, including also an attachment 503 between 500 and 501.

Fig. 9 shows a similar embodiment and view to that shown in Fig. 7, including also an inner compartment/chamber 501 with a number of inner compartment structural elements 502.

Fig. 10 shows a similar embodiment and view to that shown in Fig. 7, including also more than one siped compartment 510.

Fig. 11 and 12 show a similar embodiment and view to that shown in Fig. 7, including also more than one inner compartments 501 in an outer compartment 500.

Figs. 13 and 14 show similar embodiments and views to that shown in Fig. 7, but wherein the outer compartment/chamber/bladder 500 forms substantially all of the midsole portion of the footwear sole (exclusive

of the outer sole).

Fig. 15 shows a similar embodiment and view to that shown in Fig. 7, but also including the features of prior Fig. 11N of the '087 and '034 published Applications (as well as the 11/282,665 Application published November 9, 2006 as Pub. No. 2006/0248749 A1 incorporated by reference) and '869 Patent incorporated by reference herein, with the siped compartment/chamber/bladder 510 applied to it.

Fig. 16 shows a somewhat similar embodiment and view to that shown in Fig. 10, but including an electromagnetic shock absorption system in each chamber, which are without sipes.

Fig. 17A shows a similar embodiment and view to that shown in Fig. 15, but including an electromagnetic shock absorption system. Fig. 17B is a close-up view of an embodiment like Fig. 7, but showing magnetorheological fluid 508 located within an internal sipe 505.

Fig. 18A shows, in a frontal or sagittal plane cross section, a flexible insert or component 511 including a single compartment/chamber 161/188 or bladder with an associated internal sipe 505 component. Fig. 18B shows a horizontal plane view of 511.

Fig. 19A shows, in frontal or sagittal plane cross section, a flexible insert or component 513 forming a unitary internal sipe. Fig. 19B is a horizontal plane view of 513.

Fig. 20A shows, in frontal or sagittal plane cross section, the Fig. 19A embodiment of a unitary internal sipe 513 position as a separate component in a footwear sole. Fig. 20B is like Fig. 19B.

Fig. 21A shows, in frontal or sagittal plane cross section, the unitary internal sipe 513 in an embodiment including three separate internal flexibility sipes 505. Fig. 21B is like Fig 19B.

Fig. 22 shows, in frontal plane cross section in the heel area, a flexible insert or component 510 used in the footwear upper 21.

Fig. 23 shows, in frontal plane cross section in the heel area, a flexible insert or component 510 used both in the footwear upper 21 and in the sole 22 or 28.

Figs. 24A and 24B show, in frontal plane cross section, two example embodiments of any helmet 550 for any use with a cushioning helmet liner 551 including an inner flexible insert or component 510.

Figs. 24C and 24D show, in frontal plane cross section, two example embodiments of any helmet 550 for any use including one or more internal sipes 505

Figs. 25A and 25B, as well as Figs. 26A and 26B, show a heel section of a footwear sole or orthotic with an example of a flexible insert or component 510 using specific examples of the structural elements 502.

Fig. 26C shows an example in a horizontal plane cross-section of a footwear sole 22 of a device or flexible insert or component 510 in which the inner compartment 501 includes a flexible shank 514 located in the media 504 in the general area of the instep of the shoe sole between the heel area and the forefoot area.

Fig. 27 shows in cross-section an example of any ball 530 with one or more internal sipes 505 of any shape located between the outer surface of the ball and an inner surface.

Fig. 28A shows in cross-section an example of a tire 535, such as for a wheel of a transportation vehicle, with a device 510. Figure 28B shows in a side view cross-section an example of shape of structural elements 502 of the inner compartment 501.

Fig. 29A shows, in sagittal plane cross sections, two examples of prior art human breast implants, the first inserted over pectoral muscle and the second inserted under pectoral muscle. Figure 29B shows an example of a human breast implant 540 with a siped compartment or chamber 510.

Figs. 30A-30C show cross sectional examples of any structural or support element 550 in any device, including mechanical or architectural, including a beam or strut, or a tool or racquet handle or grip, shaft or body, or head, that incorporates a siped chamber 510.

Fig. 31A shows examples of prior art golf clubs. Figure 31B shows an example of a golf (or other) club head or racket (or tool head or body or handle/grip) 550 with one or more internal sipes 505.

Fig. 32A shows in perspective view an example of a prior art artificial spinal or intervertebral disk. Fig. 32B shows in frontal plane cross section an example of an artificial spinal or intervertebral disk 560, including any artificial joint disk or any other surgical or prosthetic device with one or more internal sipes 505 of any form,

including a siped compartment 510.

Figs. 33 and 35 show frontal plane cross section examples of shoe soles 22 or 28 or midsole insert or orthotics 145 with several planar sides to approximate curvature from the applicant's published '034 application and WIPO publication No. WO 02,09547, which can be combined with the flexible insert or components 510, 511, or 513; Fig. 34 shows a similar top view example.

Fig. 36 shows prior art from the automotive industry relating to magnetoelectric cushioning systems shown in Figs. 16 and 17.

Figs. 37-43 show perspective views of prior art examples gas bladders of Nike Air™ (119-123), which are Figs. 12-16 of U.S. Patent 6,846,534 and Zoom Air™ (124-126), which are Figs. 1-3 of published U.S. Patent Application 2005/0039346 A1.

Fig. 44 shows perspective views of prior art Adidas 1™ shoe sole electronic/electromechanical cushioning system.

Fig. 45 shows a shoe sole or orthotic cross-section of a siped compartment 510 with an inner compartment 501 having multiple midsole layers.

Fig. 46 shows a shoe sole or orthotic cross-section of a siped compartment 510 with an inner compartment 501 having a multitude of ball bearing-like structures.

Fig. 47 shows a shoe sole or orthotic cross-section of a siped compartment 510 with fiber reinforcing an inner or outer compartment.

Fig. 48A shows a shoe sole or orthotic cross-section of a siped compartment 510 with fiber sandwiched between two separate layers of midsole; Fig. 48B shows a similar embodiment example with fiber embedded in midsole layers. Figs. 48C-48E show material using vertical sipe embodiment examples from Figs. 73A-73C of the '665 Application like Figs. 25 and 26 of this application.

Figs. 49-52 show examples of the 510 invention using typical commercial air bladder embodiments as compartments 501 modified with outer compartments 500.

Fig. 53 shows an example wheel for an automobile with the 510/511/513 inventions.

Fig. 54 show prior art tire example.

Fig. 55 shows a shoe sole or orthotic cross-section of a siped compartment 510 with a mixture plastic and rubber compounds.

Fig. 56 shows a shoe sole or orthotic cross-section of a siped compartment 510 with a mixture of liquid or gel cells.

Fig. 57 shows a tire with an internal sipe 505 with a media 506 and/or fiber 516 between and inner and outer tires.

Fig. 58 shows a tire with magnetorheological fluid 508 and piezoelectric 519 components

Fig. 59 shows a glove with the 510/511/513 inventions.

Fig. 60 shows apparel with the 510/511/513 inventions.

Fig. 61A shows a computer laptop with the 510/511/513 inventions and Fig. 61B shows a semiconductor microchip with the 510/511/513 inventions.

Fig. 62 shows a chair with the 510/511/513 inventions.

Figs. 63-65 shows a mattress, pillow, and wedge cushion with the 510/511/513 inventions.

Fig. 66 shows a cable with the 510/511/513 inventions.

Fig. 67 is a chart showing approximate comparison of hardness scales.

Fig. 68 shows a building with the 510/511/513 inventions.

Figs. 69-70 shows torso and knee braces.

Figs. 71-72 shows automobile examples of the 510/511/513 inventions.

Fig. 73 shows a tennis racquet with the 510/511/513 inventions.

Figs. 74-79 show additional examples of the 510/511/513 inventions applied to electronic game controllers, manual tools, electric tools, bicycle, and cell phone.

Figs. 80A-80C show a large urban telephone book lying flat, solid wooden block, and an upright very thick book to illustrate basic concepts of sipe flexibility and stability.

Figs. 81A-81D show the much larger and more conventional attachment area between midsole and bottomsole for a shoe sole or orthotic with the 510/511/513 invention of Figs. 81C-81D compared to prior shoe sole sipe inventions of Figs. 81A-81B.

Figs 82A-87 illustrate further embodiments of the use of siped compartments or chambers (510) and/or flexible inserts and internal sipe components (511 and 513) with different shoe sole configurations.

It is understood that the reference numbers identified in this application and in U.S. Patent Application 11/282,665, incorporated by reference herein, are used consistently throughout the application such that like reference numbers are used to describe the same or like elements.

DETAILED DESCRIPTION OF THE PREFERRED EMBODIMENTS

Figures 1-79 show the applicant's inventions incorporating forms of insertable devices with one or more internal (or mostly internal) sipes, including slits (or channels or grooves and other shape, including geometrically regular or non-regular shapes, such as anthropomorphic shapes), into a large variety of products, including footwear and orthotics, athletic, occupational and medical equipment and apparel, padding for equipment and furniture, balls, tires and any other structural or support elements in a mechanical, architectural or any other device.

New reference numerals used in the Figures 1-79 are further defined as follows:

Ref. No 500: An outer compartment, such as an outer compartment 161 or chamber 188 or bladder, at least partially or mostly or entirely enclosing a space within the outer compartment/chamber/bladder 500, which can be located anywhere in a footwear sole or upper or both or other article described in this application. Construction and materials can be, as one embodiment example, simpler in shape but otherwise similar to those used in any commercial samples of Nike Air™.

Ref. No 501: An inner compartment, such as an inner compartment 161 or chamber 188 or bladder, is located inside the enclosed space of the outer compartment/chamber/bladder 500. Construction and materials of the inner compartment/chamber/bladder 501 can be, as one embodiment example, like those used in any commercial samples of gas bladders in Nike Air™.

Ref. No. 502: Structural element that is optional anywhere within either outer compartment/chamber/bladder 500 or inner compartment/chamber/bladder 501, of which a 501 embodiment is shown; any flexible, resilient material can be used, including structures molded into the shape of (and using the material of) the compartment/chamber/bladder 500 or 501, as is very common in the art, such as many commercial samples

of gas bladders used in Nike Air™, as well as foamed plastic or plastic composite or other materials, like Nike Shox™ or Impax™ or Reebok DMX™ or New Balance N-ergy™. In addition, other materials can be used directly within a 501/500 compartment or can be connected to or through a 501/500 compartment, as in the cushioning components of the shoe sole heel of commercial samples of Adidas 1™, including electromechanical, electronic, and other components. Some devices may benefit from the use of rigid or semi-rigid materials for part or all of a media within a compartment.

Ref. No. 503: Attachment of two compartment/chambers/bladders 500/501, including particularly attachment of outer 500 to inner 501; any practical number of attachments of any form using any materials can be used, including glue.

Ref. No. 504: Media contained within all or part of compartment/chamber/bladder 500 or 501, particularly 501, can be any useful material, such as gas (including, as an example, gas used in Nike Air™ or ambient air, liquid or fluid, gel, or foam (such as a plastic like PU or EVA or equivalent or rubber (natural or synthetic) or combination of two or more; encapsulation of foam is optional); material particles or coatings, such as dry coatings like Teflon™ can also be used. An optional element in an outer compartment/chamber 500 (or an inner compartment/chamber 501 that itself contains an inner compartment/chamber, as in Fig. 87).

Ref. No. 505: Internal sipe or slit or channel or groove for flexibility, such as between inner and outer compartment/chamber 500/501 (or bladder) surfaces, as one embodiment example; such surfaces can be substantially parallel and directly contact in one useful embodiment example, but are not attached so that at least parts of the two surfaces can move relative to each other, such as to facilitate a sliding motion between surfaces; the surfaces can be in other useful forms that allow portions of the surfaces to be proximate to each other but not contacting in an unloaded condition or in a partially loaded condition or in a maximally loaded condition.

Ref. No. 506: Media of internal sipe 505; media 506 can be any useful material like those used in media 504; media 506 can be located in part or all of 505 to decrease (or increase) sliding resistance between 500/501 or

505 surfaces, for example, to lubricate the surfaces with any suitable material; silicone or Teflon™ can be used, for example; an optional element.

Ref. No. 507: Metal particles.

Ref. No. 508: Shock absorbing fluid containing 507; a magnetorheological fluid.

Ref. No. 509: Electromagnetic field-creating circuit.

Ref. No. 510: A flexible insert or component including siped compartments 161 or chambers 188 or bladders used for example as outer and inner compartments/chambers/bladders 500/501 for footwear soles or orthotics or uppers or other uses; a useful embodiment being two or more compartment or chambers (or bladders) 161/188 (or mix) that are separated at least in part by an internal sipe 505, including the example of at least one 501 (either 161/188 or bladder) inside at least one 500 (either 161/188 or bladder) and being separated by an internal sipe 505.

Ref. No. 511: A flexible insert or component including a single compartment 161 or chamber 188 or bladder with an associated internal sipe 505 component.

Ref. No. 512: A wall of flexible insert or component 511 or 513 that is not formed by a compartment 161 or chamber 188 or bladder and that is separated from another wall by an internal sipe 505.

Ref. No. 513: Any flexible insert or component including an internal sipe 505.

Ref. No. 514: A flexible shank located generally in an instep area of a shoe sole and incorporated in a 510/511/513 device described herein previously.

Ref. No. 516: Ball bearings

Ref. No. 517: Liquid or gel cells

Ref. No. 518: Fibers

Ref. No. 519: Piezoelectric components

Ref. No. 521: Plastic or plastic-based compound

Ref. No. 522: Rubber or rubber-based compound

Ref. No. 530: Any ball with a device 510/511/513 described herein previously.

Ref. No. 535: A tire (for a wheel) or a wheel 533 with a device

510/511/513 described herein previously and treads 536, as well as steel belts 537.

Ref. No. 540: A human breast implant with a device 510/511/513 described herein previously.

Ref. No. 545: Transportation vehicle including its interior 546 with a device 510/511/513.

Ref. No. 550: Any structural or support element with a device 510/511/513 described herein previously, including a helmet or other apparel or equipment for humans or animals or other biologically based product; or a tool (power or manual), club, or racquet handle, grip, shaft, body, or head; a beam or strut or any other element in any device, including mechanical or architectural.

Ref. No. 560: An artificial spinal or intervertebral disk with a device 510/511/513 described herein previously.

Ref. No. 570: Apparel or clothing, including gloves 571, with a device 510/511/513.

Ref. No. 580: Computer

Ref. No. 590: Furniture

Ref. No. 610: Cable of wire or glass fiber.

Ref. No. 620: Building, including house.

Ref. No. 630: Human body braces.

Figures 1-15, 17, and 22-79 show, as numeral 510, examples of a device or flexible insert including siped compartments 161 or chambers 188 or bladders (another term used in the art) for use in any footwear soles, including conventional soles 22 or the applicant's prior inventions, including footwear/shoe soles 28 and midsole inserts 145 as described in applicant's published '087 Application and 11/282,665 U.S. Application published November 9, 2006, as Pub. No. US 2006/0248749 A1 incorporated by reference, or for orthotics 145 as described in the applicant's published '034 U.S. Application, '869 Patent, and WO 02/09547 WIPO publication, as well as to be published by WIPO PCT Application Number PCT/US2005/042341, all incorporated by reference herein, including for uppers for footwear or orthotics (or including uppers), or for other flexibility uses in athletic equipment like helmets and apparel including protective padding and

guards, as well as medical protective equipment and apparel, and other uses, such as protective flooring, improved furniture cushioning, balls and tires for wheels, and other uses.

The device or flexible insert with siped compartments or chambers 510 include embodiments like two or more of either compartments 161 or chambers 188 or bladders (or a any mix including two or more of a compartment, a chamber, and a bladder) that are separated at least in part or in several parts or mostly or fully by an internal sipe 505. The flexible insert 510 can be inserted during assembly of an article by a maker or manufacturer or is insertable by a user or wearer (into an article like a shoe, for example, as part of a removable midsole insert 145 described above), or integrated into the construction of a device as one or more components.

Siped compartments or chambers 510 include example embodiments such as Figures 1-15, 17, and 22-79 which generally show at least one inner compartment 161 or chamber 188 inside at least one other outer compartment 161 or chamber 161; and the two compartments/ chambers 161/188 being separated by an internal sipe 505.

One practical example embodiment of the invention is any prior commercial embodiment of Nike Air™ gas bladder or compartment (like typical examples in Figures 12-16 of U.S. Patent No. 6,846,534, which is hereby incorporated by reference) that is installed unattached, as is, located within the space enclosed partially or fully by a new, slightly larger outer compartment of one additional layer of the same or similar material, with the same or a simpler or the simplest geometric shape; that is, not necessarily following indentations or reverse curves, but rather incorporating straighter or the straightest lines, as seen in cross-section: for example, following the outermost side curvature seen in Figures 12-16, but with upper and lower surfaces that are substantially flat and parallel (or curved and parallel), to facilitate ease of movement between the two surfaces of the sipe 505 formed, increasing the resulting flexibility.

The new additional, outer compartment thus thereby has created by its presence an internal sipe 505 between the two unconnected compartments. The new internal sipe 505 provides much greater flexibility

to any footwear sole 22 or 28, since it allows an inner, otherwise relatively rigid Nike Air™ compartment structure to become an inner compartment 501 (instead of typically being fixed into the other materials such as EVA of the footwear sole) to move freely inside the new outer compartment 500, which becomes a new compartment that is fixed to the footwear sole, rather than the conventional Nike Air™ bladder. The flexibility improvement allows the shoe sole to deform under a body weight load like a wearer's bare foot sole, so that stability is improved also, especially lateral stability.

The result is that the conventional, inner Nike Air™ compartment -- now contained by a new outer compartment -- can move easily within the overall footwear sole, allowing the sole to bend or flex more easily in parallel with the wearer's bare foot sole to deform to flatten under a body weight load, including during locomotion or standing, so that footwear sole stability is improved also, especially lateral stability. The extent to which the inner Nike Air™ compartment is "free-floating" within the new outer compartment can be controlled or tuned, for example, by one or more attachments (permanent or adjustable) to the outer compartment or by the media in the internal sipe.

The internal sipe 505 includes at least two surfaces that can move relative to each other to provide a flexibility increase for a footwear sole so that the shape of the footwear sole can deform under a body weight load to better parallel to the shape of the barefoot sole of a wearer under a same body weight load. The relative motion between the two internal sipe 505 surfaces increases the capability of the footwear sole to bend during locomotion under a wearer's body weight load to better parallel the shape of said wearer's bare foot sole.

In an analogous way, especially to the thicker heel portion of a typical shoe sole, a thick urban area telephone book has in effect hundreds of mostly "internal sipes", each page being in effect separated by a horizontal internal slit from each adjacent page, each of which thereby is able to move freely relative to each other, resulting in a flexible telephone book that bends quite easily, while at the same time relatively stable when a vertical force like body weight is applied.

In contrast, if the same wood fiber material with the same

dimensions as a thick telephone book were formed instead into a single piece with no pages, like a solid particle board, it would be quite rigid.

If, instead, the sipes were rotated 90 degrees into vertical slits and open to the bottom, so that the spine of the telephone book is on top, those external sipes would also provide a substantial amount of flexibility, but at the cost of excessive instability when a vertical force like body weight is applied.

Also, the sliding motion between internal support surfaces within the shoe sole 28 allowed by internal sipe 505 in response to torsional or shear forces between a wearer's foot and the ground assists in controlling and absorbing the impact of those forces, whether sudden and excessive or chronically repetitive, thereby helping to protect the wearer's joints from acute or chronic injury, especially to the ankles, knees, hips, lower back, and spine.

A benefit of the siped compartments/chambers 510 is that, as a single unitary component, it can be used in any conventional manner in constructing the footwear sole 28, generally like that used with a conventional single layer compartment such as used in Nike Air™; i.e. the outer surface of 510 can, as a useful embodiment, adhere to the adjacent materials like plastic such as PU (polyurethane) or EVA (ethyl vinyl acetate) or other plastic or rubber of the footwear sole that contact the 510 component, just as would be the case with the outer surface of existing single compartment 161 or chamber 188 of commercial examples of Nike Air™. However, the internal sipe 505 formed by the use of an inner compartment/chamber 501 in the siped compartment/chamber 510 provides flexibility in a footwear sole 28 that is absent in the relatively rigid footwear sole 28 formed with a conventional, single layer compartment 161 or chamber 188 of the many Nike Air™ commercial examples.

The sipe surfaces can in one useful example embodiment be formed by the inner surface (or part or parts of it) of the outer compartment 500 and the outer surface (or part or parts of it) of the inner compartment 501. Such sipe surfaces can be substantially parallel and directly contact each other in one useful embodiment example, but the two surfaces are generally not attached to each other, so that the sipe surfaces can move relative to each other to facilitate a sliding motion between the two

surfaces.

The sipe surfaces can be in other useful forms that allow portions of the surfaces to be proximate to each other in an unloaded condition, rather than contacting; such surfaces can make partial or full direct contact under a wearer's body weight load (which can vary from a fraction of a "g" to multiple "g" forces during locomotion) or remain somewhat separated; the amount of sipe surface area making direct contact can also vary with a wearer's body weight load. The sipes surfaces also may not be parallel or only partially parallel, such as the areas of direct surface contact or proximal surface contact.

To preclude the surfaces of the internal sipe 505 from directly contacting each other (whether loaded or unloaded), the sipe surfaces can include an internal sipe media 506 located between the surfaces to reduce friction by lubrication and increase relative motion and therefore flexibility. Useful example embodiments of the internal sipe media 506 include any useful material known in the art (or equivalent), such as a liquid like silicone as one example, a dry material like Teflon™ as another example, or a gas like that used in Nike Air™ as a further example. The media 506 can be located in all of the sipe 505 or only part or parts, as shown in Figures 1-6.

The media 506 can be used to decrease (or increase) sliding resistance between the inner surfaces of the sipe; for example, to lubricate with any suitable material known in the art. The internal sipe media 506 is an optional feature.

The siped compartments/chambers 510 can be located anywhere in the footwear sole or orthotic or upper and can be used in other applications, including non-footwear applications where flexibility increases are useful). The siped compartments/chambers 510 can be made, for example, with any methods and materials common in the footwear arts or similar arts or equivalents, like those in various Nike Air™; see for example U.S. Patent Nos. 4,183,156 and 4,219,945 to Rudy (which show fluid-filled bladder manufacturing through a flat sheet bonding technique), 5,353,459 to Potter et al. (which shows fluid-filled bladders manufactured through a blow-molding process), as well as 6,837,951 and Figs. 12-16 of 6,846,534, all of which patents are herein incorporated by reference) or similar

commercial examples like Reebok DMX™ compartments in its original form, as seen for example U.S. Patent No. 6,845,573 (herein incorporated by reference), column 5, line 41 to column 6, line 9), or New Balance N-ergy™ (see for example Figure 1 of WIPO Pub. No. WO 00/70981 A1, but note that, as a example, at least the initial production versions of the N-ergy compartment can have less rigidity to allow better flexibility) or Asics Gel™ (many versions) compartments or future equivalents of any, or with less common materials, such as fibers described above incorporated into or on the surface of the material of the siped compartment/chambers 510, including either elastic fibers or inelastic fibers or a mix. The siped compartment/chambers 510 can be of any practical number in a footwear sole or any shape, of which useful example embodiments include regular geometric shapes or irregular shapes, including anthropomorphic or animal shapes; and the 510 number or shape can be symmetrical or asymmetrical, including between right and left footwear soles.

Either of the compartments 161 or chambers 188 of the siped compartment/chambers 510 (or 511 or 513) can include one or more structural elements 502 like those common in the footwear art such as in Nike Air™ as noted in the above cited Rudy and Nike patents, also including Tuned Air™ (See for example U.S. Patent No. 5,976,451 to Skaja et al, which is herein incorporated by reference and which shows manufacturing of fluid-filled bladders through a vacuum-forming process) or Zoom Air™ (See for example Figs. 1-3 of U.S. App. No. 2005/0039346 A1, which is herein incorporated by reference); a number of example embodiments of inner compartments 501 with structural elements 502 are shown in the Figures 1A, 9, 13, and 14. The structural elements 502 can be made of any useful material known in the art and constructed in any manner known in the art. Figures 25A and 26A show similar example embodiments wherein the structural elements 502 of the inner compartment 501 are formed with a specific shape and foamed plastic material such as PU or EVA like that of Nike Shox™ (See U.S. Patent Nos. 5,353,523, 5,343,639, and 6,851,204, which are herein incorporated by reference) and Nike Impax™ (U.S. D500,585 S, which is herein incorporated by reference), respectively, and can be affixed to the inner compartment 501, which can be reinforced as necessary (instead of to rigid lower and/or upper

plates); the lower surface of the outer compartment 500 can be attached to an outer sole, at least in part or an outer sole can be integrated into the outer compartment 500 by thickening, for example, or incorporating rubber or rubber substitute material. Other commercial existing examples that can be similarly modified as a device or flexible insert or component 510 (or 511 or 513) are Adidas a³™ Energy-Management Technology and Adidas™ Ground Control System (GPS)™, and Reebok DMX™ Shear Heel or other cushioning technologies.

Also, as shown in the example embodiments of Figures 26B and 25B, since foamed plastic material does not require containment (unlike a gas, liquid, or most gels), if the structural elements 502 are sufficiently interconnected, like for example Nike Impax™ in Figure 26B, or if the separate support columns 32 and midsole wedge 40 of Nike Shox™ are modified to interconnect like the example shown in Figure 25B, then those connected structural elements 502 can form an integral inner compartment 501, the outer surface of which can form an internal sipe 505 with the new outer compartment 500. The interconnection can be complete, with each structural elements 502 connected to at least the closest other elements 502, as shown, or mostly complete, or partial. The Shox™ support columns 32 can be any practical number, such as existing examples of four or five or six (all commercially available) or more in the heel and many more in the forefoot of the shoe sole 22 or 28, for a total of eleven in existing commercial examples.

Any of the compartments or chambers 161/188 of the siped compartment 510 can be permanently or temporarily attached one to another with at least one attachment 503 of any useful shape or size or number or position; embodiment examples are shown in Figures 1A, 2A, 3A, 4A, 5A, 6A, and 8. Anthropomorphic designs would suggest including positioning attachments 503 on the internal sipe 505 closest to a wearer's foot sole as a useful embodiment, so that the remaining sipes 505 would have a U shape in cross-section, like the structure of human foot sole fat pads, which are analogous to the cushioning midsole and midsole components of footwear soles.

The attachments 503 can be simply passive (i.e. static) or actively controlled by electronic, mechanical, electromagnetic, or other useful

means. The attachments 503 can, for example, be designed to break away as a failsafe feature to compensate for a predetermined extreme torsional load, for example, to reduce extreme stress on critical joints (in lieu of a wearer's cartilage, tendons, muscle, bone, or other body parts being damaged); the attachments 503 can then be reset or replaced (or, alternatively, return automatically upon relief of extreme stress to a normal position).

Example embodiments of the compartments and chambers 500/501 can include a media 504 such as a gas (like that used in Nike Air™ or ambient atmospheric air), a liquid or fluid, a gel, a foam (made of a plastic-like PU or EVA, both of which are common in the footwear art, or equivalent, or of a rubber (natural or synthetic) or blown rubber or a rubber compound or equivalent or of another useful material or of a combination of two or more of the preceding foam plastic/rubber/etc.) or a useful combination of one or more gas, liquid, gel, foam, or other useful material.

Also, any inventive combination that is not explicitly described above in the example shown in Figure 1 is implicit in the overall invention of this application and, consequently, any part of the example embodiments shown in preceding Figure 1 and/or associated textual specification can be combined with any other part of any one or more other elements of the invention or prior art examples described in Figures 2-79 and/or associated textual specification and/or, in addition, can be combined to make new and useful improvements over the existing art with any one or more other elements of the inventive or prior art examples shown in Figures 1-75 of both the applicant's prior footwear U.S. Application No. 11/190,087, published as Pub. No. 2005/0268487 A1 on December 8, 2005, and the applicant's prior orthotic U.S. Patent No. 7,010,869, issued March 14, 2006, as well as continuation U.S. Application No. 11/108,034, published as Pub. No. 2005/0217142 A1 on October 6, 2005, each of which is incorporated by reference herein for completeness of disclosure, as well as U.S. Application 11/282,665 published as Publication No. US 2006/0248749 A1, on November 9, 2006, which is also hereby explicitly incorporated by reference herein in its entirety for completeness of disclosure, as including additional Figures 76-82, any part or parts of which figure or figures can be combined with any part or

parts of any figure or figures of this application. In addition, any one or more features or components of Figure 1 and Figures 2-79 can be usefully combined with one or more features or components of Figures 1-43 of the applicant's earlier application No. 11/179,887 published as Publication No. US 2005/0241183 A1 on November 3, 2005 describing footwear, which application is hereby incorporated by reference herein.

Figures 2A, 3A, and 4A show examples of embodiments of siped compartment/chamber/bladders 510 wherein either the inner compartment/chamber/bladder 501 or the outer compartment 500 can have one or more openings, for pressure equalization, assembly facilitation, or other purposes.

Also, any inventive combination that is not explicitly described above in the example shown in Figure 2-4 is implicit in the overall invention of this application and, consequently, any part of the example embodiments shown in preceding Figure 2-4 and/or associated textual specification can be combined with any other part of any one or more other elements of each other or the invention examples described in Figures 1 and 5-79 and/or associated textual specification, in addition, can be combined to make new and useful improvements over the existing art with any one or more other elements of each other or the inventive or prior art examples shown in prior published Figures 1-75 of the '869 Patent and the '087, '034 and '665 Applications, as well as additional Figures 76-82 of the '665 Application, and also added Figures 1-43 of the '887 Application.

Figure 5A shows an example embodiment with an inner compartment/chamber/bladder 501¹ having a smaller inner compartment/chamber/bladder 501²; additional smaller inner compartments 501 are possible in a similar progression, either enclosed within the previous larger inner compartment 501 or within the same 501 or 500.

Figure 6A shows an example embodiment with two inner compartment/chamber/bladders 501¹ and 501² which are layered within outer compartment/chamber/bladder 500; additional compartment/chamber 501 layers can be useful also.

Figure 1B shows an example embodiment of the device 510 in a horizontal plane view of Figures 1A, 2A, 3A, 4A, 5A, and 6A.

Also, any inventive combination that is not explicitly described

above in the example shown in Figures 5-6 is implicit in the overall invention of this application and, consequently, any part of the example embodiments shown in preceding Figure 5-6 and/or associated textual specification can be combined with any other part of any one or more other elements of the invention examples described in Figures 7-79 and/or associated textual specification and/or, in addition, can be combined to make new and useful improvements over the existing art with any one or more other elements of each other or the inventive or prior art examples shown in prior published Figures 1-75 of the '869 Patent and the '087, '034 and '665 Applications, as well as additional Figures 76-82 of the '665 Application, and also added Figures 1-43 of the '887 Application.

Figures 7-15 and 17 show, in frontal plane cross sections in the heel area, example footwear embodiments with siped compartment/chambers 510 located in footwear soles 28, which are shown with curved sides but which sides can also be planar in another embodiment; or which is shown with flattened inner and outer surfaces underneath the wearer's foot sole but which can be curved in a different embodiment.

Figure 7 shows an example embodiment with single outer compartment 500 and a single inner compartment/chamber/bladder 501.

Figure 8 shows a similar example embodiment with an attachment 503 between 500 and 501.

Figure 9 is a similar example embodiment to that shown in Figure 7 and includes also an inner compartment/chamber/bladder 501 with a number of structural elements 502.

Figure 10 shows an example embodiment with more than one siped compartment/chambers 510, including outer compartment/chamber/bladders 500, each with an inner compartment/chamber/bladder 501; not shown is another example embodiment with more than one inner compartments/chamber/bladders 501 in each of more than one outer compartment/chamber/bladder 500, another among many useful variations.

Also, any inventive combination that is not explicitly described above in the examples shown in Figures 8-10 is implicit in the overall invention of this application and, consequently, any part of the example embodiments shown in preceding Figures 8-10 and/or associated textual specification can be combined with any other part of any one or more other

elements of each other or the invention or prior art examples described in Figures 1-7 and 11-79 and/or associated textual specification and/or, in addition, can be combined to make new and useful improvements over the existing art with any one or more other elements of each other or the inventive or prior art examples shown in prior published Figures 1-75 of the '869 Patent and the '087, '034 and '665 Applications, as well as additional Figures 76-82 of the '665 Application, and also added Figures 1-43 of the '887 Application.

Figure 11 shows a similar example embodiment to Figure 7 and including a number of inner compartment/chamber/bladders 501 within a single outer compartment/chamber/bladder 500, as does Figure 12. Any practical number of inner compartment/chamber/bladders 501 can be a useful embodiment of the general invention.

Also, any inventive combination that is not explicitly described above in the examples shown in Figures 7 and 11-12 is implicit in the overall invention of this application and, consequently, any part of the example embodiments shown in preceding Figures 7 and 11-12 and/or associated textual specification can be combined with any other part of any one or more other elements of each other or the invention or prior art examples described in Figures 1-6, 8-10, and 13-79 and/or associated textual specification and/or, in addition, can be combined usefully with any one or more other elements of each other or the inventive or prior art examples shown in prior published Figures 1-75 of the '869 Patent and the '087, '034 and '665 Applications, as well as additional Figures 76-82 of the '665 Application, and also added Figures 1-43 of the '887 Application.

Figures 13 and 14 show example embodiments wherein the outer compartment/chamber/bladder 500 forms substantially all of the footwear sole, exclusive of the outer sole 149 in the example shown (but the insert 510 can form the outer surface of the footwear sole also). A heel cross-section is shown, but other sections of the sole, such as the forefoot or midfoot can employ this approach, either as separate components or each can be used alone or in combination with others or as substantially all of the sole 28. As shown, both Figures 13 and 14 example embodiments include multiple inner compartment/chamber/bladders 501 in layers.

Also, any inventive combination that is not explicitly described

above in the examples shown in Figures 13-14 is implicit in the overall invention of this application and, consequently, any part of the example embodiments shown in preceding Figure 13-14 and/or associated textual specification can be combined with any other part of any one or more other elements of each other or the invention or prior art examples described in Figures 1-12 and 15-79 and/or associated textual specification and/or, in addition, can be combined usefully with any one or more other elements of each other or the inventive or prior art examples shown in prior published Figures 1-75 of the '869 Patent and the '087, '034 and '665 Applications, as well as additional Figures 76-82 of the '665 Application, and also added Figures 1-43 of the '887 Application.

Also, any inventive combination that is not explicitly described above in the example shown in Figure 15 is implicit in the overall invention of this application and, consequently, any part of the example embodiments shown in preceding Figure 15 and/or associated textual specification can be combined with any other part of any one or more other elements of the invention examples described in Figures 1-14 and 16-79 and/or associated textual specification and/or, in addition, can be combined with any one or more other elements of the inventive or prior art examples shown in prior published Figures 1-75 of the '869 Patent and the '087, '034 and '665 Applications, as well as additional Figures 76-82 of the '665 Application, and also added Figures 1-43 of the '887 Application.

Figure 16 shows an example embodiment of chambers 188 for any footwear soles, including conventional, or other flexibility uses with an electromagnetic shock absorption system similar to, for example, the Cadillac™ "Magnetic Ride Control" system, wherein magnetically sensitive metal particles 507 suspended in a shock absorbing fluid 508 are made less fluid in effect by controlling, on for example a millisecond basis, an electromagnetic field-creating circuit 509 that aligns the metal particles 507 into a flow resistant structure. The fluid 508 is thus a magnetorheological fluid, that is, a fluid which generally solidifies into a pasty consistency when subject to a magnetic field.

Figure 17A shows an example embodiment like Figure 11N of applicant's incorporated published '087, '034 and '665 Applications and '869 Patent wherein the flow between chambers 188 is controlled by

controlling the flow resistance of the fluid 508 by the circuit 509 located to affect the fluid 508 in one or more of the chambers 188; alternatively, the flow can be controlled by the circuit 509 being located between the chambers.

Fig. 17A shows a similar embodiment and view to that shown in Fig. 15, but including an electromagnetic shock absorption system. Fig. 17B is a close-up view of an embodiment like Fig. 7, but showing magnetorheological fluid 508 located within an internal sipe 505.

The Figure 16-17 example embodiments can be located anywhere in the footwear sole (and can be used in other applications, including non-footwear applications where flexibility increases are useful). The Figure 16-17 embodiments can be made with any materials common in the footwear art, like those in various Nike Air™ commercial examples, or future equivalents, or with less common materials, such as fibers described earlier, including either elastic fibers or inelastic fibers or a mix. The Figure 16-17 example embodiments can be of any practical number in a footwear sole, or any shape, of which useful embodiments include regular geometric shapes or irregular shapes, including anthropomorphic shapes; and the number or shape can be symmetrical or asymmetrical, including between right and left footwear soles.

Also, any inventive combination that is not explicitly described above in the examples shown in Figures 16-17 is implicit in the overall invention of this application and, consequently, any part of the example embodiments shown in preceding Figure 16-17 and/or associated textual specification can be combined with any other part of any one or more other elements of each other or the invention or prior art examples described in Figures 1-15 and 18-79 and/or associated textual specification and/or, in addition, can be combined with any one or more other elements of each other or the inventive or prior art examples shown in prior published Figures 1-75 of the '869 Patent and the '087, '034 and '665 Applications, as well as additional Figures 76-82 of the '665 Application, and also added Figures 1-43 of the '887 Application.

Figure 18 shows an example embodiment of a flexible insert or component 511 including a single compartment/chamber 161/188 or bladder with an associated internal sipe 505 component, again for any footwear

sole, including conventional 22, or other flexibility uses (such as those described above relative to insert 510), to form a single unitary siped compartment or chamber; the sipe 505 can extend to part or all of one side of the single compartment 500, as shown, or the sipe 505 can extend around portions of the other sides of the single compartment/chamber/bladder 500; Figure 18B shows an example embodiment in a horizontal plane view of 511.

The flexible insert 511 can be inserted during assembly of an article by a maker or manufacturer or is insertable by a user or wearer (into an article like a shoe, for example, as part of a removable midsole insert described above), or integrated into the construction of an article as one or more components.

A benefit of the single siped compartment/chamber/bladder 511 is that, as a single unitary component like 510, it can be used in a conventional manner in constructing the footwear sole 28, like that used with a conventional single layer compartment in Nike Air™; i.e. the outer surface of 511 can, as a useful embodiment, adhere to the adjacent material of the footwear sole that contact the 511 component, just as would the outer surface of a single compartment 161 or chamber 188. However, the internal sipe 505 component of the siped compartment/chamber/bladder 511 provides flexibility in a footwear sole 28 that is absent in the relatively rigid footwear sole 28 formed with a conventional, single layer compartment 161 or chamber 188.

The siped compartments/chamber/bladder 511 can be located anywhere in the footwear sole (and can be used in other, non-footwear applications where flexibility increases are useful). The siped compartment/chamber/bladders 511 can be made with any materials common in the footwear art, like those in various Nike Air™ commercial examples, or future equivalents, or with less common materials, such as fibers described earlier, including either elastic fibers or inelastic fibers or a mix. The siped compartment/chamber/bladders 511 can be of any practical number in a footwear sole, or any shape, of which useful embodiments include regular geometric shapes or irregular shapes, including anthropomorphic shapes; and the number or shape can be symmetrical or asymmetrical, including between right and left footwear soles.

Also, any inventive combination that is not explicitly described

above in the example shown in Figure 18 is implicit in the overall invention of this application and, consequently, any part of the example embodiments shown in preceding Figure 18 and/or associated textual specification can be combined with any other part of any one or more other elements of the invention examples described in Figures 1-17 and 19-79 and/or associated textual specification and/or, in addition, can be combined usefully with any one or more other elements of each other or the inventive or prior art examples shown prior published Figures 1-75 of the '869 Patent and the '087, '034 and '665 Applications, as well as additional Figures 76-82 of the '665 Application, and also added Figures 1-43 of the '887 Application.

Figure 19A shows an example embodiment of a flexible insert or component 513 forming a unitary internal sipe for any footwear sole or orthotic or upper, including conventional sole 22, or other flexibility uses (such as those described above relative to insert 510), the embodiment shown employing a single internal flexibility sipe 505 in the form of a slit; Figure 19B shows an example embodiment in a horizontal plane view of Figures 19A, 20A, and 21A. Multiple unitary internal sipes 513 can be used independently or synergistically anywhere in a footwear sole in other useful embodiments not shown; the sipes 513 can be stacked proximate to one another or apart, as viewed in a frontal or sagittal plane, for example; or the sipes 513 can overlap, as viewed in a horizontal plane, for example. The flexible insert 513 can be inserted during assembly of an article by a maker or manufacturer or is insertable by a user or wearer (into an article like a shoe, for example, as part of a removable midsole insert described above), or integrated into the construction of an article as one or more components.

In one useful example embodiment, the unitary internal sipe 513 can be made as a separate sole component like an extremely thin conventional gas compartment similar to a Nike Air™ compartment, but without the typical internal compartment structures (which in another useful embodiment can be present in some form if unattached to at least one inner surface so that relative motion between inner surfaces can occur to provide increased flexibility).

A benefit of the unitary internal sipe 513 is that, as a single

insertable unitary component like 510 and 511, it can be used in a conventional manner in constructing the footwear sole 28, roughly like that used with a conventional single layer compartment in Nike Air™; i.e. the outer surface of 513 can, as a useful embodiment, adhere to the other portions of the footwear sole that contact the 513 component, just as would the outer surface of a single compartment 161 or chamber 188.

The unitary internal sipe 513 can be located as a separate component anywhere in the footwear sole (and can be used in other applications, including non-footwear applications where flexibility increases are useful). The insertable unitary internal sipe 513 can be made with any materials common in the footwear art, like those in various Nike Air™ commercial examples, or future equivalents, or with less common materials, such as fibers described earlier, including either elastic fibers or inelastic fibers or a mix. The unitary internal sipe 513 can be of any practical number in a footwear sole, or any shape, of which useful example embodiments include regular geometric shapes or irregular shapes, including anthropomorphic shapes; and the number or shape can be symmetrical or asymmetrical, including between right and left footwear soles.

Figure 20A shows the Figure 19A example embodiment of a unitary internal sipe 513 positioned as a separate component in an embodiment of a footwear sole 28; alternatively, in another example embodiment not shown, the unitary internal sipe 513 can be completely enclosed in conventional midsole material like PU or EVA or similar material.

Figure 21A shows the unitary internal sipe 513 in an example embodiment including three separate internal flexibility sipes 505, which in one embodiment can be completely enclosed in conventional midsole material such as PU or EVA or similar material. Generally, unitary internal sipes 513 can thus be subdivided into any practical number of smaller unitary internal sipes that are aggregated together (or can be positioned alone, as described earlier).

Also, any inventive combination that is not explicitly described above in the examples shown in Figures 19-20 is implicit in the overall invention of this application and, consequently, any part of the example embodiments shown in preceding Figures 19-20 and/or associated textual

specification can be combined with any other part of any one or more other elements of each other or the invention or prior art examples described in Figures 1-18 and 21-79 and/or associated textual specification and/or, in addition, can be combined usefully with any one or more other elements of each other or the inventive or prior art examples shown in prior published Figures 1-75 of the '869 Patent and the '087, '034 and '665 Applications, as well as additional Figures 76-82 of the '665 Application, and also added Figures 1-43 of the '887 Application.

Figure 22 shows an example embodiment of a flexible insert or component 510 with siped compartment/chamber/bladders used in the footwear upper 21 for use in embodiments like the Reebok Pump™ and Pump 2.0™; the flexible insert or component 510 can be positioned anywhere in upper 21, including an orthotic; 511 and 513 can be used also.

Figure 23 shows an example embodiment of a flexible insert or component 510 that is substantially forming the footwear upper 21 in part of the heel and which can be used anywhere else are in all of the upper 21. Note also that the flexible insert or component 510 shown as an example in Figure 23 also shows the flexible insert or component 510 positions so that it is located in both the upper 21 and in the shoe sole or in both an orthotic and orthotic upper; 511 and 513 can be used also.

Also, any inventive combination that is not explicitly described above in the examples shown in Figures 22-23 is implicit in the overall invention of this application and, consequently, any part of the example embodiments shown in preceding Figures 22-23 and/or associated textual specification can be combined with any other part of any one or more other elements of each other or the invention or prior art examples described in Figures 1-21 and 24-79 and/or associated textual specification and/or, in addition, can be combined usefully with any one or more other elements of each other or the inventive or prior art examples shown in prior published Figures 1-75 of the '869 Patent and the '087, '034 and '665 Applications, as well as additional Figures 76-82 of the '665 Application, and also added Figures 1-43 of the '887 Application.

Figures 24A and 24B show, in frontal plane cross section, two example embodiments of any helmet 550 for any use with a cushioning helmet liner 551 including an inner flexible insert or component 510; any useful

number of flexible inserts or components 510 can be used; flexible insert or components 511 and 513 can be used also. The invention includes any helmet 550 (or part or parts of the helmet) with a liner 551 with one or more internal sipes 505 of any form previously described in this application and any material known in the art located anywhere between the outer surface and inner surface of the helmet liner 551.

Figures 24C and 24D show, in frontal plane cross section, two example embodiments of any helmet 550 for any use including one or more internal sipes 505 of any form previously described in this application and any material known in the art located anywhere between the outer surface and inner surface of the helmet 550, and can include, for example, a shock and shear-absorbing media 504 as previously described in this application.

Also, any inventive combination that is not explicitly described above in the examples shown in Figures 24A-24D is implicit in the overall invention of this application and, consequently, any part of the example embodiments shown in preceding Figures 24A-24D and/or associated textual specification can be combined with any other part of any one or more other elements of each other or the invention or prior art examples described in Figures 1-23 and 25-79 and/or associated textual specification and/or, in addition, can be combined usefully with any one or more other elements of each other or the inventive or prior art examples shown in prior published Figures 1-75 of the '869 Patent and the '087, '034 and '665 Applications, as well as additional Figures 76-82 of the '665 Application, and also added Figures 1-43 of the '887 Application.

Also, any inventive combination that is not explicitly described above in the example shown in Figure 24 is implicit in the overall invention of this application and, consequently, any part of the example embodiments shown in preceding Figure 24 and/or associated textual specification can be combined with any other part of any one or more other elements of the invention or prior art examples described in Figures 1-23 and 25-79 and/or associated textual specification and/or, in addition, can be combined usefully with any one or more other elements of the inventive or prior art examples shown in prior published Figures 1-75 of the '869 Patent and the '087, '034 and '665 Applications, as well as additional

Figures 76-82 of the '665 Application, and also added Figures 1-43 of the '887 Application.

Figures 25A and 25B, as well as Figures 26A and 26B, show a heel section of a footwear sole or orthotic with an example of a flexible insert or component 510 using specific examples of the structural elements 502 based on commercial examples of Nike Shox™ and Nike Impax™. Figures 25A and 26A show an example of those structural elements of foam material contained and affixed within an inner compartment 501. Since use of a foamed material as a media does not require containment to maintain its structure and function (in contrast to a gas, liquid, or most gels), a foamed material do not require a separate inner compartment 501 in order to form an internal sipe 505 with the new outer compartment 500, as noted under the section on compartment 500/501 media 504 below; thus, as shown in the examples of Figures 25B and 26B, suitably configured (in terms of interconnections and shape, for example) structural elements 502 of a foamed material can form an integral inner compartment 501 creating an internal sipe 505 with outer compartment 500.

Figure 26C shows an example in a horizontal plane cross-section of a footwear sole 22 of a device or flexible insert or component 510 in which the inner compartment 501 includes a flexible shank 514 located in the media 504 in the general area of the instep of the shoe sole between the heel area and the forefoot area. The flexible shank 514 can be made of any rigid or semi-rigid material including plastic, metal, and composites including carbon-fiber common in the art and can have sipes 151, of which a vertical slit is one example among a very many well known in the art, that are generally oriented from the area of the heel to the area of the forefoot (including at an angle) so that the shoe sole 22 is flexible enough to flatten in following the deformation motion of a wearer's foot sole in a full range of pronation and supination motion, while remaining sufficiently rigid to support naturally the instep area of the shoe sole 22, a area that is relatively thin (often with tapered thickness) and therefore not ground-contacting in many common footwear soles popular in the art and therefore unstable without shank support, which is well known in the art but which is typically too narrow to support directly the base of a wearer's fifth metatarsal and too rigid in a frontal plane to follow

a wearer's lateral pronation/supination motion.

Figure 26D shows two different examples of versions of the flexible shank 514 in frontal plane cross section. The upper version shows on the left side vertical sipes 151 as slits that penetrate the shank fully and which can be held together, especially during assembly, by an attached fiber (or other material, like foam, for example) layer, while on the right side is another variation of sipes (among the vast number of possibilities discussed in the applicant's prior patents), which are slits 151' that do not fully penetrate the flexible shank 514. The lower version shows an example of inverted V shaped channels as another sipe variation, with the left side showing full or near full penetration (and again, a fiber or other layer can be attached) and the right side showing the channels connected by portions of the flexible shank 514.

Also, any inventive combination that is not explicitly described above in the example shown in Figures 25-26 is implicit in the overall invention of this application and, consequently, any part of the example embodiments shown in preceding Figures 25-26 and/or associated textual specification can be combined with any other part of any one or more other elements of each other or the invention or prior art examples described in Figures 1-24 and 27-79 and/or associated textual specification and/or, in addition, can be combined usefully with any one or more other elements of each other or the inventive or prior art examples shown in prior published Figures 1-75 of the '869 Patent and the '087, '034 and '665 Applications, as well as additional Figures 76-82 of the '665 Application, and also added Figures 1-43 of the '887 Application.

Figure 27 shows in cross-section an example of any ball 530 with one or more internal sipes 505 of any shape located between the outer surface of the ball and an inner surface. The ball includes a structure like the device or flexible insert 510 above, with an inner compartment/chamber/bladder 501 in a typical example having a media 504, which can be pressured gas like air that is sealed (like a tennis ball) or controlled by a valve (not shown) common in the commercial art, like a basketball, and with an outer compartment/chamber/bladder 500. Alternatively, the ball can be structured like a typical golf ball with a solid or relatively solid core (with one or more layers of material) as

media 504, which would be separated from the tough outer layer by an internal sipe 505, which can be made to reduce the uncontrolled spin of an offcenter shot like a slice or hook, since any spin imparted to the compartments at the instant of club contact with the ball would become relatively disconnected after contact, with the outer compartment encountering air resistance to its spin, while the core of the inner compartment 501 would encounter friction from the internal sipe 505 surfaces. A similar design and construction approach involving an internal sipe 505 can be used with other devices like skis, bats, tool handles.

Also, any inventive combination that is not explicitly described above in the example shown in Figure 27 is implicit in the overall invention of this application and, consequently, any part of the example embodiments shown in preceding Figure 27 and/or associated textual specification can be combined with any other part of any one or more other elements of the invention or prior art examples described in Figures 1-26 and 28-79 and/or associated textual specification and/or, in addition, can be combined usefully with any one or more other elements of the inventive or prior art examples shown in prior published Figures 1-75 of the '869 Patent and the '087, '034 and '665 Applications, as well as additional Figures 76-82 of the '665 Application, and also added Figures 1-43 of the '887 Application.

Figure 28A shows in cross-section an example of a tire 535, such as for a wheel of a transportation vehicle, with a device 510; the internal sipe 505 and/or inner compartment/chamber/bladder 501 can be pressured or not (valve not shown). As shown in the example, inner compartment/chamber/bladder 501 can have one or more direct attachments 503 to the wheel and the structural elements shown can be made of any useful material as is conventional in the art, including plastic and/or plastic composite and/or carbon fiber. The outer compartment/chamber/bladder 500 can be abbreviated to cover only part of inner compartment/chamber/bladder 501, as shown in Figure 28, (possibly pressure-sealed to the wheel like a conventional automobile tire and wheel); the outer compartment/chamber/bladder 500 can also be abbreviated further to cover only a lesser portion, including at least a tread

portion, which can include rubber (natural or synthetic, as can other or all parts of the outer compartment 500. Figure 28B shows in a side view cross-section an example of shape of structural elements 502 of the inner compartment 501 (not shown for simplicity).

Also, any inventive combination that is not explicitly described above in the example shown in Figure 28 is implicit in the overall invention of this application and, consequently, any part of the example embodiments shown in preceding Figure 28 and/or associated textual specification can be combined with any other part of any one or more other elements of the invention or prior art examples described in Figures 1-27 and 29-79 and/or associated textual specification and/or, in addition, can be combined usefully with any one or more other elements of each other or the inventive or prior art examples shown in prior published Figures 1-75 of the '869 Patent and the '087, '034 and '665 Applications, as well as additional Figures 76-82 of the '665 Application, and also added Figures 1-43 of the '887 Application.

Figure 29A shows, in sagittal plane cross sections, two examples of prior art human breast implants, the first inserted over pectoral muscle and the second inserted under pectoral muscle. Figure 29B shows an example of a human breast implant 540 with a siped compartment/chamber/bladder 510 in any of the forms described earlier in this application. The breast implant 540 can be located like either of the prior art examples in Figure 29A or in another position, or, alternatively, can be incorporated in a pad worn externally to the wearer's body. Similar implants 540 incorporating a siped compartment/chamber/bladder 510 including of anatomical or anatomically compatible shape can be used anywhere else in or on the human body, or in or on the body of an animal or other biological entity, utilizing any material in the known implant or other art, including new equivalents, for both functional and/or cosmetic purposes, including external use. More generally, the implant 540 can be any pad incorporating one or more internal sipes 505 of any 510/511/513 form described earlier in this application located anywhere within the implant 540 (or connecting to the outer surface of 500).

Figures 30A-30C show cross sectional examples of any structural or

support element 550 in any device, including mechanical, electro-mechanical, architectural, electronic, optical, or biological, including a beam or strut, or a tool or racquet handle or grip, shaft or body, or head, that incorporates a siped compartment/chamber/bladder 510 of any form described earlier in this application located anywhere within the structural or support element 550. More generally, the structural or support element 550 can be element incorporating one or more internal sipes 505 of any 510/511/513 form described earlier in this application located anywhere within the structural or support element 550 (or connecting to the outer surface of 500). The sipe or sipes 505 can include one or more sipe media 506 (or 508) that can lubricate the sipe so that 510/511/513 can recoil or rebound after a force impact or load with better flexibility, which can be tuned.

Figure 31A shows examples of prior art golf clubs. Figure 31B shows an example of a golf (or other) club head or racket (or tool head or body or handle/grip) 550 with one or more internal sipes 505 of any 510/511/512 form described previously in this application located anywhere within said club 550 (or connecting to the outer surface of 500).

Figure 32A shows an example of a prior art artificial spinal or intervertebral disk. Figure 32B shows an example of an artificial spinal or intervertebral disk 560, including any artificial joint disk or any other surgical or prosthetic device for human or animal with one or more internal sipes 505 of any 510/511/513 form previously described within this application located anywhere within the outer surface of disk 560 (or connecting to the outer surface of 500). The artificial disk 560 can be located between endplates 561, as in the example shown in Figure 32B.

Figures 33-35 show examples of shoe soles 22 or 28 or midsole insert or orthotics 145 with several planar sides to approximate curvature from the applicant's WIPO publication No. WO 02,09547, which can be combined with the flexible insert or components 510, 511, or 513, including with the examples shown in Figures 1-32 and 36-79.

Also, any inventive combination that is not explicitly described above in the example shown in Figures 29-35 is implicit in the overall invention of this application and, consequently, any part of the example embodiments shown in preceding Figure 29-35 and/or associated textual

specification can be combined with any other part of any one or more other elements of each other or the invention or prior art examples described in Figures 1-28 and 36-79 and/or associated textual specification and/or, in addition, can be combined usefully with any one or more other elements of each other or the inventive or prior art examples shown in prior published Figures 1-75 of the '869 Patent and the '087, '034 and '665 Applications, as well as additional Figures 76-82 of the '665 Application, and also added Figures 1-43 of the '887 Application.

Figure 36 shows background information from the automotive industry relating to Figures 98 and 99.

Figures 37-43 show prior art examples gas bladders of Nike Air™ (119-123), which are Figures 12-16 of U.S. Patent 6,846,534 and Zoom Air™ (124-126), which are Figures 1-3 of published U.S. Patent Application 2005/0039346 A1.

Figure 44 shows Adidas 1 shoe sole electronic or electromechanical cushioning system (pg. 96 Popular Science, 12/04).

Reference numeral 28 refers to the applicant's footwear sole inventions in this and prior footwear/orthotic applications and patents, but reference numeral 28 also refers to orthotics and/or corrective footwear in this application, as well as in the applicant's prior footwear applications and patents that are incorporated by reference herein. This is because footwear soles 28 themselves can be custom modified in a manner conventional to the orthotic and/or corrective shoe art with individualized correction made to the footwear sole 28 as if the entire sole 28 were an orthotic device, rather than just to an orthotic insert 145; potentially included are differing corrections between right and left footwear soles 28 as necessary, as is conventional in the orthotic/corrective shoe art.

Reference numeral 148 refers to midsole, a middle sole layer between the bottom sole and the shoe upper; the midsole has been in commercial use for about forty years, primarily to provide cushioning in modern footwear in the form of relatively soft foamed plastic or other elastomeric material that compresses relatively easily under the body weight load of a wearer of a footwear/orthotic sole 28. Standard midsole material in the

footwear art is the use of a foamed plastic like EVA or PU, as well as other foamed elastomeric materials indicated in paragraph number 0178 of the '087 Application incorporated by reference herein earlier or equivalent materials.

Since the primary function of midsole 148 in the footwear art is to provide cushioning, such foamed plastics in general use are relatively soft, ranging typically from a fairly soft 30 durometers on a Shore A Hardness Scale to a relatively harder 60 durometers and about 40-70 durometers on the Asker C Hardness Scale.

It is the applicant's view that these standard ranges of midsole hardness are excessively soft in order to compensate for the general commercial use of a non-optimal, not sufficiently anthropomorphic shape for the basic structure of footwear/orthotic soles 28. That is, the softness of the midsole material allows conventional footwear/orthotics 22, especially the sides, to bend up more easily into a shape more like that of a wearers foot sole subjected to a body weight load. The applicant's firm view that the more direct and effective approach is to obviate the need to compensate by using an anthropomorphically shaped footwear/orthotic sole 28 structure, as described previously by the applicant in this and the applicant's prior footwear applications and patents incorporated by reference herein. Moreover, recent human biomechanics research indicates a counter-intuitive result: that softer midsole cushioning actually causes higher impact forces for a wearer.

Consequently, based on the foregoing, the only direct way to achieve a lower, more natural level of impact forces on a wearer is to form a new combination of significantly firmer midsole material together with the correct, anthropomorphic footwear/orthotic sole 28 shape previously described by the applicant. However, increased firmness alone results in instability, since footwear/orthotic soles 28 that are rounded and that do not flatten easily like the rounded sole of an unloaded wearer's foot does under a body weight load will function instead roughly like a rigid rocking chair, not a foot sole, which is rounded but flattens easily under body weight.

Therefore, increased material firmness must be newly combined with increased structural flexibility provided by the applicant's internal sipe

inventions 510/511/513 in order to create footwear/orthotic soles 28, or removable midsole/orthotic inserts 145, that are both rounded like the shape of a wearer's unloaded foot sole and deformable so as to flatten like that wearer's rounded foot sole flattens under a body weight load. As a direct result, at the same time impact forces on a wearer are reduced to a natural, bare foot level, while "energy return" is increased to a natural, bare foot level, instead of the relative energy loss (actually, "negative energy return") of conventional athletic shoe soles compared to the bare foot.

The use of midsole 148 material that is firmer than that which is standard in the footwear art therefore has significant functional benefits in combination with the applicant's internal sipe inventions. Such relatively firm or hard midsole 148 material for footwear/orthotic soles 28 and inserts 145 can usefully be on a Shore A Hardness Scale, for example, greater than 60 durometers, such as at least 65 durometers, at least 70 durometers, at least 75 durometers, at least 80 durometers, at least 85 durometers, at least 90 durometers, at least 95 durometers, or 100 durometers; or midsole 148 material that is on a Shore D Hardness Scale at least 20 durometers or at least 30 durometers or at least 40 durometers or at least 50 durometers or at least 60 durometers or at least 70 durometers or at least 80 durometers or at least 90 durometers; or midsole material that is on the Asker C Hardness Scale greater than 70 durometers or over 75 durometers or over 80 durometers or over 85 durometers or over 90 durometers or over 95 durometers or 100 durometers.

Accordingly, for each of the embodiments disclosed in this application, the midsole material 148 may be designed with this increased firmness/hardness as discussed in this paragraph above (for example, a hardness of greater than 60 durometers).

The midsole 148 used in the applicant's footwear or orthotic inventions can have multiple layers, each with different durometers (of either scale), such varying from a firmest nearest to an outsole and a least firm nearest to a wearer's foot sole.

Also, since the applicant's view outlined above is that the function of midsole 148 material is to provide flexibility, not to provide cushioning, then the use of conventional foamed material is no longer

required, given that the injection of gas to create cells within conventional midsole 148 material as identified earlier is done to produce an unnecessary cushioning property into the 148 material. Therefore, reduced foam or non-foamed plastic or other reduced foam or non-foamed elastomeric (or non-elastomeric materials) or combination thereof can be usefully employed with improved function in the footwear/orthotic soles 28 and removable midsole/orthotic inserts 145 of this application or the applicant's prior footwear applications and patents incorporated by reference herein above. Similarly, reduced cell (open or closed) or non-cell plastic or other reduced cell (open or closed) or non-cell elastomeric (or reduced or non-elastomeric) materials or combination thereof can be usefully employed with improved function in the footwear/orthotic soles 28 and removable midsole/orthotic inserts 145 of this application or the applicant's prior footwear applications and patents incorporated by reference herein above.

Note that the above reduced foam or non-foam and/or reduced cell or non-cell elastomeric (or reduced or non-elastomeric) midsole 148 material described in this paragraph can be otherwise the same as those remaining midsole 148 materials (but without foam and/or cells or reduced foam and/or reduced cells in terms of size or number) indicated previously in paragraph 0178 of the '087 application. Associated with this reduction would be a cessation or reduction in the gas injected in the midsole 148 manufacturing or injection process. Note the reduction in cells above can be in number (per unit volume, for example) or size or both, and reduced foam and/or cells can be measured in increased weight per unit such as volume of material, for example.

In summary, it is the use of the applicant's insertable internal sipe inventions, including the 510/511/513 inventions of this application, not midsole 148 foamed or cellular material, that can provide natural flexibility and impact force reduction like the foot sole of the wearer. In combination with the applicant's novel insertable internal sipe invention, this new to the footwear art midsole 148 material described above uniquely provides a new capability for footwear/orthotic soles 28 to function in the same manner and with the same performance characteristics as a wearer's foot sole - an important capability unavailable with

conventional foamed or celled midsole 148 material. And this beneficial new combination can also be combined usefully with any of the applicant's prior footwear/orthotic sole 28 and removable midsole/orthotic insert 145 to produce other new invention with improved; more natural performance characteristics.

The bottom or outer sole 149 is often made, at least in one or more parts, with blown rubber for cushioning and flexibility, so that it is similar in structure and function to foamed, celled midsole 148 material described previously. For the same reasons described previously then, the use of non-blown rubber (or reduced cell/foam rubber) combined with the applicant's internal sipe inventions, such as the 510/511/513 inventions of this application, provide useful improvements to footwear/orthotics 28 and removable midsole/orthotic inserts 145, and can also usefully be employed in conjunction with the reduced foam or non-foam and/or reduced cell or non-cell midsole 148 material described in the previous paragraph.

For both reduced foam or non-foam and/or reduced cell or non-cell midsole 149 or bottom sole 149 materials, the new materials share the new property of less or no substantial reduction in thickness under compression from a body weight load of a wearer, while rigidity is avoidable through the flexibility provided by the applicant's internal sipes inventions, including the 510/511/513 inventions of this application. Incompressible solids, that is, materials that can be deformed but do not change in volume are described by the Mooney-Rivlen equation, which can be useful in identifying material properties with optimal material characteristic desired by the applicant, which is minimal thickness reduction under compression, but with maximal flexibility.

The additional use of fiber, including inelastic but flexible fiber, is beneficial in assisting the new midsole 148 (or bottom sole 149) to reduce compression deformation while maintain flexibility of the footwear/orthotic 28 or insert 145, especially if the fiber 518 is located or oriented substantially in a plane at least roughly paralleling the inner surface of the sole 28 or insert 145 which should follow the outer surface of the wearer's foot sole.

The firm or hard material described above for midsole 148 and bottom sole 149 provides better responsiveness than softer materials, a desirable

characteristic for athletic shoes particularly and generally better stability for any footwear/orthotic soles 28 or inserts 145. Similarly, reduced foam or non-foam and/or reduced cell or non-cell sole 148 or 149 material allows for thinner footwear/orthotic soles 28 or inserts 145, which reduces the torque inherent in the thickness of the sole 28 or insert 145, thereby also increasing responsiveness and decreasing instability, such as related to ankle sprains or over-pronation.

Moreover, the applicant's 510/511/513 are uniquely designed to reduce shear forces, rather than compression force (which as noted above is probably unnecessary), since most artificial surfaces like concrete or asphalt significantly increase shear forces above a natural level, compared to a natural surface like grass or dirt (either loose or packed).

In addition, the potentially excessive bulkiness of the applicant's curved stability sides shown in this and earlier applications and patents incorporated by reference herein above is reduced by the thinner sole 28 or insert 145.

Potential midsole 148 and outsole 149 materials include elastomers, rubber, and plastic, as noted above, including polymers (used singularly or in combination); examples are polyolefins, fluoropolymers, and vinyls, as well as polypropylene, polystyrene, nylon, polycarbonate and acrylics, including in the form of fibers. Also, materials with a flexural modulus higher or much higher than is standard in the art is beneficial.

The new firm or hard, reduced foam or non-foam and/or reduced cell or non-cell 148 or 149 materials described above on this and the previous three pages can be used beneficially with footwear/orthotic soles 28 and uppers 21, as well as removable midsole/orthotic inserts 145, and also with any other of the previously or later described non-footwear/orthotic products, including, for example, helmets 550, balls 530, tires 535, implants or external pads or other protection 540, structural elements 550 including golf clubs 550, artificial joints like spinal disks 560, and many other products described or listed in this or previous applications and patents previously incorporated by reference herein.

The same logic described above that indicates the improvements provided by using firm-to-hard, reduced foam or non-foam and/or reduced cell or non-cell 148 or 149 material also applies to materials used in the

applicant's internal sipe inventions, including the 510/511/513 inventions of this application, including for example midsole material used in either the 504 or the 502 components (or both) of the siped compartment 510 and 511 inventions.

By the same logic, any gas or "air" used in the 510/511/513 or earlier inventions is less beneficial, although still a useful improvement to the prior art. Furthermore, by this logic, either compartment/chamber/bladder 500 or 501 can contain a firm-to-hard, reduced foam or non-foam and/or reduced cell or non-cell midsole 148 material, either in a single layer or multiple layers separated by internal sipes 505 (one or more) between layers, for example a single sipe 505 between two midsole 148 material layers, such as in the example embodiment shown in Figure 45, wherein the inner compartment 501 contains two midsole layers. Any practical number of midsole layers of any shape and associated sipes 505 of any shape is possible, with each additional associated sipe 505 providing additional flexibility to the compartment/chamber/bladder 500 or 501.

Figure 46 shows a different example embodiment wherein the inner compartment/chamber/bladder 501 shown contains a multitude of ball bearing-type structures made of a midsole 148 material that is firm-to-hard, reduced foam or non-foam and/or reduced cell or non-cell, as described above. The ball bearings 516 can be fixed or free-moving within the inner compartment 501, so that for example if the ball bearings 516 are sufficiently firm-to-hard, the bearings 516 can create significant pressure points against a wearer's foot sole since the bearings 516 would not compress significantly under a wearer's body weight load, but if relatively free-moving within compartment 501 (or alternatively, with compartment/chamber/bladder 500, such as free-moving within a sipe 505, for example), the ball bearing 516 pressure points can move sufficiently within the compartment/chamber/bladder 501 to provide thereby a foot massage to a wearer of the footwear/orthotic sole 28 or removable midsole or orthotic insert 145 with a compartment/chamber/bladder 501 or sipe 505 with sufficiently firm-to-hard ball bearings 516, which also assist in developing healthy protective calluses (rather than potentially blisters if the ball bearings 516 were fixed in the same positions so that the

point pressure did not move, such as randomly, which protects the foot sole)

Figure 47 shows an embodiment example wherein flexible fiber is used to reinforce one or more compartment/chamber/bladders 500 or 501, as shown, wherein elastic or inelastic fibers 518 can be used to help stabilize the size and shape of the one or more compartments/chambers/bladders 500 or 501, such as for example under a body weight load of a wearer, to reduce compression of the sole. Note the fiber 518 shown parallel the shape of the inner surface 30 of the footwear/orthotic sole 28, which parallels the shape of a wearer's foot sole.

Figure 48A shows another example embodiment with fiber 518 wherein the fiber 518 is sandwiched between two separate layers of midsole 148 (or bottom sole 149) material, including firm-to-hard, reduced foam or non-foam and/or reduced cell or non-cell; alternatively, the fiber 518 can be embedded within the midsole 148, as shown in Figure 48B, or bottom sole 149 material; multiple layers of fiber and/or midsole 148 can be a useful improvement, again as shown in Figure 48B.

Figures 48C-48E show alternate embodiment examples of shoe sole material incorporating vertical sipes based on Figures 73A-73C of the '665 Application that would be incorporated in shoe soles in the manner shown in Figures 25B and 26B for Figure 48C and Figures 25A and 26A for Figures 48D and 48E.

Figures 49-51 show examples of embodiments of the useful improvement of applicant's siped compartment/chamber/bladder 510 invention combined with the gas bladders 501 well known in the art as made by Nike™ and marketed as Nike Air™ (and shown previously as Figures 38-40). Figure 52 is a similar example embodiment incorporating a New Balance N-ergy™ cartridge as a compartment/chamber/bladder 501 in the applicant's siped compartment 510 invention.

Any one or more parts of Figures 45-52 can be combined with any one or more parts of one or more of the previous Figures of this or the applicant's prior footwear applications or patents incorporated by reference herein. Also, any inventive combination that is not explicitly described above in the example shown in Figures 45-52 is implicit in the

overall invention of this application and, consequently, any part of the example embodiments shown in preceding Figure 45-52 and/or associated textual specification can be combined with any other part of any one or more other elements of each other or the inventive and prior art examples described in Figures 1-44 and 53-79 and/or associated textual specification and/or, in addition, can be combined usefully with any one or more other elements of each other or the inventive or prior art examples shown in prior published Figures 1-75 of the '869 Patent and the '087, '034 and '665 Applications, as well as additional Figures 76-82 of the '665 Application, and also added Figures 1-43 of the '887 Application.

Figure 53 is an example of a wheel/tire combination, the Michelin™ "Tweel" with the wheel 533 including the 510/511/513 invention and Figure 54 is a prior art example of a conventional tire.

Figure 55 is a cross-section enlarged view of slightly more than half of a footwear/orthotic sole 28 comprising at least in part or entirely a mixture or mixtures of any kind of plastic 521 polymers and elastomers and rubber 522 or compounds and combinations thereof, including mixtures including particles or components (including microscopic or at the molecular level) of any number (per unit volume, for example), size, or shape, including compounds with minimal or no substantial or no compression under a body weight load, and can include liquid or gel injection molding. The benefit of the mixture material is to create a single material with more flexibility than a typical bottom sole 149 material, while at the same time providing better durability than a typical midsole material 148, including new forms of those materials described by the applicant previously. Optionally, the applicant's 510 and 511 inventions can also in the same manner include the same mixture or another mixture as described in this paragraph, as can removable midsole/orthotic inserts 145.

Figure 56 is a similar cross-section to Figure 55 showing a portion of a footwear/orthotic sole 28 comprising at least in part or entirely a midsole 148 material including cells 517 that include a liquid or gel, either partially or substantially or completely. The liquid or gel cells 517 can be of any number (per unit of volume, for example), or size, or shape, and the midsole 148 material surrounding the cells can be non-

compressible or not substantially compressible or minimally compressible. The benefit of this material structure is that the liquid or gel cell would be at least minimal compression under a body weight load, in marked contrast to the substantial compression and associated degraded performance of conventional midsole 148 materials with convention gas cells. Liquid or gel injection molding can be utilized therefore in place of gas injection molding.

Any one or more parts of Figures 55-56 can be combined with any one or more parts of one or more of the previous Figures of this or the applicant's prior footwear applications or patents incorporated by reference herein. Also, any inventive combination that is not explicitly described above in the example shown in Figures 55-56 is implicit in the overall invention of this application and, consequently, any part of the example embodiments shown in preceding Figures 44-56 and/or associated textual specification can be combined with any other part of any one or more other elements of each other or the invention and prior art examples described in Figures 1-54 and 57-79 and/or associated textual specification and/or, in addition, can be combined usefully with each other or any one or more other elements of the inventive or prior examples shown in prior published Figures 1-75 of the '869 Patent and the '087, '034 and '665 Applications, as well as additional Figures 76-82 of the '665 Application, and also added Figures 1-43 of the '887 Application.

Figures 57 and 58 are additional examples of embodiments of the applicant's 510/511/513 inventions applied to tire 535 design, as were earlier Figures 28A and 28B. Figure 57 shows a cross-section of a tire 535 embodiment with an outer tire 500 and an inner tire 501, with an internal sipe 505 between the two tires 500 and 501; and the sipe 505 shown includes media 506 and/or fiber 518, such as Kevlar™ and/or carbon fiber or any other fiber (or steel or other metal cable), on for example the outer surface of the inner tire 501 (or embedded therein or thereon).

Figure 58 shows an example embodiment of a tire 535 with an internal sipe 505 above the tread 526 area and, for one example, above steel belts 525; the internal sipe 505 includes a Magnetorheological Fluid 508 and in proximity to the sipe 505, such as directly above as shown, can be Piezoelectric components 519 that can provide activating current under

stress such as tire deformation to the magnetic fluid 508 to make it resistant to further deformation; i.e., the greater the stress deformation, the greater the resistance to further deformation, making the tire 535 a self-powered active suspension component.

Any one or more parts of Figures 53 and 57-58 can be combined with any one or more parts of one or more of the previous Figures of this or the applicant's prior footwear applications or patents incorporated by reference herein. Also, any inventive combination that is not explicitly described above in the example shown in Figures 53 and 57-58 is implicit in the overall invention of this application and, consequently, any part of the example embodiments shown in preceding Figures 53 and 57-58 and/or associated textual specification can be combined with any other part of any one or more other elements of each other or the invention and prior art examples described in Figures 1-52, 54-56, and 59-79 and/or associated textual specification and/or, in addition, can be combined usefully any one or more other elements of each other or the inventive examples shown in prior published Figures 1-75 of the '869 Patent and the '087, '034 and '665 Applications, as well as additional Figures 76-82 of the '665 Application, and also added Figures 1-43 of the '887 Application.

Figure 59 shows a perspective view of a glove 571 (or mitten or mitt, such as a baseball mitt, with an example embodiment of the applicant's 510 or 511 or 513 invention in two areas; any of the inventions can be used in any area of the glove or any number or in combination with each other and can be asymmetrical between right and left, or any other of the previously described variations can be used beneficially.

Figure 60 shows a perspective view of example embodiments of protective apparel or clothing 570 such as pant or shorts with the applicant's 510 or 511 or 513 invention used in two areas, but other embodiments with any of the previously described variations can be used beneficially.

Any one or more parts of Figures 59-60 can be combined with any one or more parts of one or more of the previous Figures of this or the applicant's prior footwear applications or patents incorporated by reference herein. Also, any inventive combination that is not explicitly

described above in the example shown in Figures 59-60 is implicit in the overall invention of this application and, consequently, any part of the example embodiments shown in preceding Figures 59-60 and/or associated textual specification can be combined with any other part of any one or more other elements of each other or the invention and prior art examples described in Figures 1-58 and 61-79 and/or associated textual specification and/or, in addition, can be combined usefully with any one or more other elements of each other or the inventive or prior art examples shown in prior published Figures 1-75 of the '869 Patent and the '087, '034 and '665 Applications, as well as additional Figures 76-82 of the '665 Application, and also added Figures 1-43 of the '887 Application.

Figure 61A shows a perspective view of a laptop personal computer 580 or any other electronic device with one of a potential multitude of potential example embodiments of the applicant's 510 or 511 or 513 inventions described above are used in two areas, but other useful embodiments with any of the previously described variations can be employed beneficially. For example, as shown, the 510/511/513 inventions can be used for cushioning selected corners of the laptop or can be integrated in the laptop frame in the same or other areas; and/or individual components of the laptop computer such as a harddrive can be protected by being mounted in a protected 510/511/513, such as the housing of the harddrive forming an inner compartment 501 of the 510 sided compartment invention. Fig. 61B shows a semiconductor microchip device 581 example including a part of a die or an entire die or multiple dies assembled together using the applicant's 510/511/513 invention; other devices 581 can include other micro- and nanotechnology devices, including microelectromechanical systems (MEMS), field-programmable gate arrays (FPGA's) and faraday cages, photovoltaic cells, fuel cells, batteries, and including devices assembled at the molecular or anatomic scale.

Any one or more parts of Figures 61A-61B can be combined with any one or more parts of one or more of the previous Figures of this or the applicant's prior footwear applications or patents incorporated by reference herein. Also, any inventive combination that is not explicitly described above in the example shown in Figures 61A-61B is implicit in the overall invention of this application and, consequently, any part of the

example embodiments shown in preceding Figures 61A-61B and/or associated textual specification can be combined with any other part of any one or more other elements of each other or the invention and prior art examples described in Figures 1-60 and 62-79 and/or associated textual specification and/or, in addition, can be combined usefully with any one or more other elements of each other or the inventive or prior art examples shown in prior published Figures 1-75 of the '869 Patent and the '087, '034 and '665 Applications, as well as additional Figures 76-82 of the '665 Application, and also added Figures 1-43 of the '887 Application.

Figure 62 shows a perspective view of a piece of cushioned furniture 590, such as the chair shown, with an example embodiment of the applicant's 510 or 511 or 513 invention shown in the seat cushion and the back cushion, but many other embodiments with any of the previously described variations can be usefully employed.

Figure 63 shows a perspective view of a bed with a mattress 591 having an example embodiment of the applicant's 510 or 511 or 513 invention, which can also be used as a separate mattress topper, and either can be in the form of many other embodiments with any of the previously described variations.

Figures 64 and 65 show perspective view of a pillow 591 and a wedge cushion 591, respectively, each with an example embodiment of the applicant's 510 or 511 or 513 invention, and many other embodiments with any of the previously described variations can be usefully employed with either.

Any one or more parts of Figures 62-65 can be combined with any one or more parts of one or more of the previous Figures of this or the applicant's prior footwear applications or patents incorporated by reference herein. Also, any inventive combination that is not explicitly described above in the example shown in Figures 62-65 is implicit in the overall invention of this application and, consequently, any part of the example embodiments shown in preceding Figures 62-65 and/or associated textual specification can be combined with any other part of any one or more other elements of each other or the invention and prior art examples described in Figures 1-61 and 66-79 and/or associated textual specification and/or, in addition, can be combined usefully with any one

or more other elements of each other or the inventive or prior art examples shown in prior published Figures 1-75 of the '869 Patent and the '087, '034 and '665 Applications, as well as additional Figures 76-82 of the '665 Application, and also added Figures 1-43 of the '887 Application.

Figure 66 shows a cross-section through radius view of the roughly circular example embodiment of a cable 610 of wire or optical fiber or waveguide (including optical omniguide), for example, with inner and outer layers and an internal sipe 505 between layers, as one example of the applicant's 510 or 511 or 513 inventions; alternatively, Figure 66 can show a hose schematically, with the center hollow and proportionately larger. Many other useful embodiments of either with any of the previously described variations are potentially beneficial.

Any one or more parts of Figure 66 can be combined with any one or more parts of one or more of the previous Figures of this or the applicant's prior footwear applications or patents incorporated by reference herein. Also, any inventive combination that is not explicitly described above in the example shown in Figure 66 is implicit in the overall invention of this application and, consequently, any part of the example embodiments shown in preceding Figure 66 and/or associated textual specification can be combined with any other part of any one or more other elements of the invention and prior art examples described in Figures 1-65 and 67-79 and/or associated textual specification and/or, in addition, can be combined usefully with any one or more other elements of the inventive or prior art examples shown in prior published Figures 1-75 of the '869 Patent and the '087, '034 and '665 Applications, as well as additional Figures 76-82 of the '665 Application, and also added Figures 1-43 of the '887 Application.

Figure 67 shows a chart displaying "Approximate Comparison of Hardness Scales". Products using the 510 or 511 or 513 inventions can be made of any material and any material hardness shown in chart, including Rockwell C and B Scales and Brinell Hardness Scale, including metallic and ceramic, generally for non-cushioning, relatively rigid structural elements into which a degree of flexibility is to be introduced using the applicant's 510/511/513 inventions, specific examples of which are shown in Figures 24C-24D, 30A-30C, 31B, 32B, 61, 68, 69, 71, and 73A .

Figure 68 shows an example of a building 620 such as a house including a foundation, the building including a multitude of architectural components including any structural component with any of the applicant's 510/511/513 inventions, including foundation, wall, flooring, door, ceiling, window, and roof components.

Figure 69 shows an example of a human torso brace 630 with any of the applicant's 510/511/513 inventions with cushioning components and/or more rigid protective components.

Figure 70 shows an example of a knee brace 630 with inner pads 631 with any of the applicant's 510/511/513 inventions

Any one or more parts of Figures 69-70 can be combined with any one or more parts of one or more of the previous Figures of this or the applicant's prior footwear applications or patents incorporated by reference herein. Also, any inventive combination that is not explicitly described above in the example shown in Figures 69-70 is implicit in the overall invention of this application and, consequently, any part of the example embodiments shown in preceding Figures 69-70 and/or associated textual specification can be combined with any other part of any one or more other elements of each other or the invention and prior art examples described in Figures 1-68 and 71-79 and/or associated textual specification and/or, in addition, can be combined usefully with any one or more other elements of each other or the inventive or prior art examples shown in prior published Figures 1-75 of the '869 Patent and the '087, '034 and '665 Applications, as well as additional Figures 76-82 of the '665 Application, and also added Figures 1-43 of the '887 Application.

Figure 71 shows that any of the structural components of an example of a transportation vehicle 645 such as a automobile, bus, truck, motorcycle, boat, barge, airplane, helicopter, blimp, or any other transportation or work vehicle can beneficially incorporate any of the applicant's 510/511/513 inventions.

Figure 72 shows that any of the cushioning components of an example of an interior 646 of a transportation vehicle such as a automobile, bus, truck, motorcycle, boat, barge, airplane, helicopter, blimp, or any other transportation or work vehicle can beneficially incorporate any of the applicant's 510/511/513 inventions.

Figure 73B shows a prior art tennis racquet and Figure 73A shows an example of a tennis or other sports racquet 550 or sports stick for hockey or lacrosse or golf club shaft that can beneficially incorporate any of the applicant's 510/511/513 inventions.

Figures 74-79 show other examples such as electronic game controllers or any other remote controllers 580, manual tools 550, power tools 550, household tools 550 like electric irons, bicycles 640 and cell phones 580 that can beneficially incorporate any of the applicant's 510/511/513.

Any one or more parts of Figures 68 and 71-79 can be combined with any one or more parts of one or more of the previous Figures of this or the applicant's prior footwear applications or patents incorporated by reference herein. Also, any inventive combination that is not explicitly described above in the example shown in Figures 68 and 71-79 is implicit in the overall invention of this application and, consequently, any part of the example embodiments shown in preceding Figures 68 and 71-79 and/or associated textual specification can be combined with any other part of any one or more other elements of each other or the invention and prior art examples described in Figures 1-67 and 69-70 and/or associated textual specification and/or, in addition, can be combined usefully with any one or more other elements of each other or the inventive or prior art examples shown in prior published Figures 1-75 of the '869 Patent and the '087, '034 and '665 Applications, as well as additional Figures 76-82 of the '665 Application, and also added Figures 1-43 of the '887 Application.

Figure 80A shows that, in an analogous way, especially to the thicker heel portion of a typical shoe sole, a thick urban area telephone book has in effect hundreds of mostly "internal sipes", each page being in effect separated by a horizontal internal slit from each adjacent page, each of which thereby is able to move freely relative to each other, resulting in a flexible telephone book that bends quite easily as is well known by all, while at the same time relatively stable when a vertical force like body weight is applied. Figure 80B shows, in contrast, if the same wood fiber material with the same dimensions as a thick telephone book were formed instead into a single piece of wood with no pages, like a solid particle board, it would be quite rigid with little flexibility,

although it will support a body weight stably. Figure 80C shows if, instead, the sipes were rotated 90 degrees into vertical slits and open to the bottom, so that the spine of a much wider telephone book with shorter pages is on top (in the form of a shoe sole with deep open external sipes, those external sipes would also provide a substantial amount of flexibility like that of the human foot sole, but at the cost of excessive instability when a vertical force like body weight is applied, as is obvious from common experience, since the pages will splay out uncontrollably.

Figures 81A-81D shows the a significant benefit of the applicant's insertable sipe component 510/511/513 compared to the applicant's earlier sipe invention, which is shown in Figure 81A (which is Figure 12B of the !665 application), wherein sipes are indicated by numerals 181 and 182, which allows an inner midsole section 188 to move freely inside outer midsole sections 184 and a bottom sole 149. The sipes are created by not gluing the three sections together during assembly of the shoe sole except where the outer midsole sections 184 join the bottom sole 149 at numeral 8. Figure 81B highlights the very small area of the glue joint, which requires a delicate and new manufacturing glue step of great accuracy during assembly and a resulting relatively weak joint between bottom sole and midsole, for example.

Figure 81C shows an example of the applicant's 510 invention that illustrates the much larger glue joint between midsole and bottomsole surfaces allowed through the use of the outer chamber 500 component, all of which can be glued to the surrounding midsole and bottomsole in a conventional assembly fashion, so that manufacturing of a shoe sole with the 510 invention is much simpler and unchanged from normal current practice for assembling conventional shoe soles with gas bladders like Nike Air™ and the resulting bond between bottomsole and midsole is much more secure, similar to that of a conventional shoe sole. Figure 81D shows the very much larger surface area 8 used for gluing the bottom sole 149 to the outer midsole 184 (compared to the small glue area 8 shown in Figure 81B and resulting much weaker joint between sole components in the earlier Figure 81A sipe invention than in conventional shoe soles).

Any example of a new invention shown in the preceding Figures 1-81 and/or associated textual specification can be combined with any other part of any one or more other of the prior art or the applicant's prior invention examples shown in Figures 1-3, 5-7, 9, 11-42, 44-52, 55-62, 64-82 from prior published Figures 1-75 of the '087, '034 and '665 Applications and '869 Patent, and Figures 76-82 of the '665 Application, as well as Figures 1-43 of the '887 Application (all of which have been herein incorporated by reference), and/or combined with any one or more other of subsequent new inventions shown in the examples described in Figures 1-79 and/or associated textual specification of this application to make new and useful improvements over the existing art.

The many preceding examples of embodiments of the applicant's inventions, devices or flexible inserts or components 510, 511, and 513, have many useful applications. Generally, the resilient inserts 510, 511, and 513 can be used for cushioning an object or a user, including cushioning equipment and apparel for athletic or non-athletic, occupational, recreational, medical, and other uses, including a footwear sole or upper or orthotic or orthotic upper, as well as over-the-counter footwear inserts, such as pads, insoles or arch supports.

The flexible inserts or components 510, 511, and 513 can be used in any protective clothing, like flexible insert 510 in the interior of the helmet shown in Figure 24 that can be employed for any typical helmet applications, examples including sports like American football, biking, climbing or hockey and others; occupational, like construction or military or others; and transportation, like motorcycle, bicycle, automobile, or other; the flexible insert 510 (or 511 or 513 as useful alternatives) is shown as padding inside a relatively hard or semi-hard outer shell protective material including materials like plastic, carbon-fiber, ceramic, or other composites or metal or combinations thereof. The flexible inserts 510, 511, and 513 can be used in a similar shell construction for athletic or military protective equipment like face masks (which can be attached or integrated into the helmet), neck, shoulder, chest, hip, knee or elbow, shin and forearm guards, thigh or biceps guards, groin, hand, foot, and other guards, pads, or protectors.

Alternatively, flexible inserts or components 510, 511, and 513 can

be used as padding alone or with a soft or relatively soft outer surface (without a hard shell) for medical uses (prescriptive or over the counter) like generally in the field of orthopaedics (like braces, such as back or leg or ankle braces and replacement spinal or other disks for spinal or other joint surgery or non-joint surgery), plastic surgery (including breast and other fatty deposit replacement/enhancement implants), prosthetics and podiatrics, and elderly or recuperative care to protect the above noted anatomical structures and for dental applications, like mouth guards (athletic teeth protectors and night guards and braces); in addition, similar padding can be used on artificial limbs and other prosthetic devices or braces and handles or grips, such as for crutches, walkers, canes; or in sports rackets or tools, like hammers, including powered, and handlebars, and guns and rifles and other devices with recoil shock; or for safety padding for crash protection, such padding for automobile dashboards or seat backs (including in airplanes, buses, and crash safety inflatable air bags).

Broadly, the flexible inserts or components 510, 511, and 513 can be usefully employed anywhere that cushioning already is being used, including bed and other furniture cushioning (including for special seating needs, like bicycle or other seats), packaging for shipping, luggage, playground and other flooring, protective padding or cases for equipment of any sort, including portable devices like PC laptops or video players and/or games, cell phones, personal digital assistants (PDA's), and personal digital music players like Apple Ipods™ and MP3 players, as examples, such as the mounting of delicate electronic (or other) components like hard-drives or for vibration dampening, such as in automobile structural and body components and connections.

In addition, if not otherwise shown in this application, one or more features or components of the example embodiments of the applicant's new footwear inventions shown in the preceding new Figures 1-23 and 25-26 and associated textual specification can be usefully employed in novel combination, for example, with one or more features or components of the applicant's previous inventive shoe soles and orthotics as described in Figures 1-82 of U.S. Application 11/282,665 published as Publication No. US 2006/0248749 A1 on November 9, 2006, as well as PCT Application Number

PCT/US2005/042341WIPO which was published on 1 June 2006 as International Publication No. WO 2006/058013, which are each independently hereby explicitly incorporated by reference herein in its entirety for completeness of disclosure, including but not limited to those combinations that: incorporate uppers that envelope the midsole and/or outsole and/or other features shown in published application '665 prior Figures 5-7 and 13; incorporate anthropomorphic shapes and/or chambers and/or other features shown in prior Figures 9 and 10; incorporate integral or insertable orthotics or microprocessor-controlled variable pressure and/or other features shown in prior Figure 11; incorporate sipes and/or other features shown in prior Figure 12; use uniform thickness (measured in frontal plane cross-sections) in rounded sole side or sole bottom portions, especially at essential support and stability elements and/or other features shown in prior Figures 14-16, 29-46 and 76-77; use increased or decreased (or variable) thickness in rounded sole side portions and/or other features shown in prior Figures 17-20, 24, and 27-28; use increased or decreased density or firmness in rounded sole side or bottom portions and/or other features shown in prior Figures 21-23 and 25-26; use rounding of the outer surface of the midsole on a sole side and/or other features shown in prior Figure 43A; employ bent-in rounded sides and/or other features shown in prior Figure 47; uses bulges with or without uniform thickness, at important support or propulsion areas and/or features shown in prior Figures 48 and 75; incorporates a flat heel (meaning no heel lift) and/or other features shown in prior Figures 51A-51E; incorporates negative heel embodiments and/or other features shown in prior Figures 49A-49D and 50A-50E; use rounded sides with variable thickness and firmness and/or other features shown in prior Figure 52; employs sipes and/or other features shown in prior Figures 53-57, 70-71 and 73; incorporates fiber and/or multiple layers of chambers and/or other features shown in prior Figures 58-60; employ shoe soles or orthotics with sufficient width throughout or at specific portions to support a wearer's bone structures throughout a full range of motion and/or other features shown in prior Figures 61-65 and 72; uses relatively planar sides with rounded underfoot sole portions and/or other features shown in prior Figures 66 and 67; uses similarly shaped rounding on sole sides of

different thickness at different parts of the sole and/or other features shown in prior Figure 69; uses a variation of heel or forefoot lifts and/or other features shown in Figure 74; and/or other features shown in prior Figures 78-82.

The prior published Figures 1-75 in the preceding paragraph are the same Figures 1-75 of the applicant's two earlier applications, U.S. Application No. 11/190,087 published as Publication No. US 2005/0268487 A1 on December 8, 2005 describing footwear and U.S. Application No. 11/108,034 published as Publication No. US 2005/0217142 A1 on October 6, 2005 describing orthotics, as well as U.S. Patent 7,010,869, issued March 14, 2006 (of which the '034 Application is a continuation). Both of those '087 and '034 Applications and their U.S. publications and the '869 Patent are hereby expressly incorporated by reference in its entirety for completeness of disclosure of the applicant's combination of one or more features or components of those prior published Figures 1-75 with one or more features or components of Figures 1-23 and 25-26 of the present application, as described in the preceding paragraph.

In addition, one or more features or components of Figures 1-23 and 25-26 of the present application can be usefully combined with one or more features or components of Figures 1-43 of the applicant's earlier application No. 11/179,887 published as Publication No. US 2005/0241183 A1 on November 3, 2005 describing footwear. The '887 is hereby expressly incorporated by reference in its entirety for completeness of disclosure of such novel combinations of any part or parts of this application, including any one or more features or components of new Figures 1-23 and 25-26 described in this application, and any one or more features or components of prior Figures 1-43 from any part or parts of the '887 application (and/or additionally combined with any part or parts of the preceding '087 and/or '034 applications or the '665 application). More explicitly, any one or more features or components of new Figures 1-23 and 25-26 described in this application can be usefully combined with any one or more features or components of '887 Figures 5-7 with uppers that envelope the midsole and/or outsole and/or other features shown; '887 Figures 9-10, 12E, 12F, 13E, and 14A with anthropomorphic shapes and/or chambers and/or other features shown; '887 Figures 11, 12A-12D and 13A-D

with footwear soles incorporating fibers and/or other features shown; '887 Figures 16A-D through 27 with footwear sole internal sipes and/or other features shown; '887 Figures 28-30 with sufficient width in the form of rounded sides to support neutrally the full range of a wearer's ankle and foot motion and/or other features shown; '887 Figures 31 and 32A-32M with footwear sole support, including for women's high heel pumps, at one or more of the applicant's essential stability elements and/or other features shown; '887 Figures 35-40 with footwear sole sipes in the form of slits and channels and/or other features shown; '887 Figures 41-42 with footwear soles having uniform frontal plane thickness (measured in a frontal plane cross-section) and natural flattening deformation under a wearer's body weight and/or other features shown; and '887 Figure 43 with footwear soles having rounded sides with higher density midsole sides and/or other features shown.

Any combination that is not explicitly described above is implicit in the overall invention of this application and, consequently, any part of the inventions shown in the examples shown in preceding Figures 1-79 and/or textual specification can be combined with any other part of any one or more other inventions shown in Figures 1-79 and/or associated textual specifications and also can be combined with any one or more other inventive examples of published '665 application prior Figures 1-82 and/or textual specification of this application to make new and useful improvements over the existing art.

Published '665 Application prior figures 1-82 and associated textual specification are also the same - verbatim - as the applicant's PCT application No. PCT/US01/13096, published by WIPO as WO 01/80678 A2 on 1 November 2001; for completeness of disclosure, WO 01/80678 A2 in its entirety is also herein incorporated by reference into this application, as is PCT/US01/23865, published by WIPO as WO 02/09547 A2 on February 7, 2002, both of which are available to the public in English on the WIPO Web Site in their entirety. Also incorporated by reference herein is published PCT Application No. PCT/US2005/042341, which is the same in its entirety as the '665 Application.

The '547 WIPO publication, titled "Shoe Sole Orthotic Structures and Computer Controlled Compartments", is also incorporated herein by

reference to provide additional information on the applicant's prior orthotic inventions, which can usefully be combined with the orthotic inventions described and claimed in this application. However, the applicant's insertable midsole orthotic 145 in the '547 Publication (and the above referenced '034 application on orthotics) is very similar to the applicant's removable midsole insert 145 as described in this application and can generally be understood to be the same in structure and materials, although with a principal difference. Typically, an orthotic 145 is designed specifically for an individual wearer, unlike almost all footwear, which is mass-produced using lasts based on average foot shapes for specific populations; the only exception is custom footwear, which is relatively rare and simply cobbled more directly to the individual shape of the wearer's feet. The principal difference is that typically orthotics 145 are designed to be prescribed, for example, by a qualified expert like a health care professional such as a doctor or podiatrist in order to treat a wearer's diagnosed footwear-related problem; generally, orthotics 145 are for prescriptive, therapeutic, corrective, or prosthetic uses.

The applicant's other footwear U.S. Patent Numbers 4,989,349; 5,317,819; 5,544,429; 5,909,948; 6,115,941; 6,115,945; 6,163,982; 6,308,439; 6,314,662; 6,295,744; 6,360,453; 6,487,795; 6,584,706; 6,591,519; 6,609,312; 6,629,376; 6,662,470; 6,675,498; 6,675,499; 6,708,424; 6,729,046; 6,748,674; 6,763,616; 6,789,331; 6,810,606; 6,877,254; 6,918,197; 7,010,869; 7,082,697; 7,093,379; 7,127,834; 7,168,185; and 7,174,658 are hereby incorporated by reference herein in their entirety into this application for completeness of disclosure of the applicant's novel and useful combination of one or more of any of the features or components of any of the figures of this application with one or more of any of the features of any one or more of the preceding applicant's patents listed above in this paragraph.

The applicant's other footwear published U.S. Application Numbers 20020000051; 20020007571; 20020007572; 20020014020; 20020014021; 20020023373; 20020073578; 20020116841; 20030046830; 20030070320; 20030079375; 20030131497; 20030208926; 20030217482; 20040134096; 20040250447; 20050016020; 20050086837; 20050217143; and 20060032086 are

hereby incorporated by reference herein in their entirety into this application for completeness of disclosure of the applicant's novel and useful combination of one or more of any of the features or components of any of the figures of this application with one or more of any of the features of any one or more of the preceding applicant's published U.S. Applications listed above in this paragraph.

In the following claims, the term "chamber" means a compartment 161 or a chamber 188 or a bladder and the term "sipe" means a sipe 505 or a slit or a channel or a groove as described in the textual specification above and associated figures of this application.

The foregoing shoe designs meet the objectives of this invention as stated above. However, it will clearly be understood by those skilled in the art that the foregoing description has been made in terms of the preferred embodiments and various changes and modifications may be made without departing from the scope of the present invention which is to be defined by the appended claims.

WHAT IS CLAIMED IS:

1. A device for a footwear sole or footwear upper or both, or an orthotic or orthotic upper or both, or another product, including:
 - an outer chamber;
 - at least one inner chamber inside said outer chamber;
 - said outer chamber and said inner chamber being separated at least in part by an internal sipe; and
 - at least a portion of a surface of said outer chamber forming at least a portion of a surface of said internal sipe.
2. The device according to claim 1, wherein said internal sipe has opposing surfaces that are separate from each other and therefore can move relative to each other; and
 - at least a portion of said opposing surfaces are in contact with each other in a unloaded condition.
3. The device according to any one of claims 1-2, wherein said sipe is a slit.
4. The device according to any one of claims 1-3, wherein the surfaces of said slit are substantially parallel and in direct contact with each other.
5. The device according to any one of claims 1-4, wherein the sole or orthotic having a lateral sidemost section located outside a straight vertical line extending through the shoe sole or orthotic at a lateral sidemost extent of the inner surface of the sole or orthotic, as viewed in a frontal plane cross-section when the sole or orthotic is upright and in an unloaded condition;
 - the sole or orthotic having a medial sidemost section located outside a straight vertical line extending through the shoe sole or orthotic at a medial sidemost extent of the inner surface of the sole or orthotic, as viewed in a frontal plane cross-section when the sole or orthotic is upright and in an unloaded condition; and

said outer compartment extends at least from a part of said lateral sidemost section to a part of said medial sidemost section, as viewed in a frontal plane cross-section when the sole or orthotic is upright and in an unloaded condition.

6. The device according to any one of claims 1-5, wherein said outer compartment extends into said lateral or medial sidemost section to a height above a lowest point of said inner surface of said sole or orthotic, as viewed in said frontal plane cross-section when the shoe sole is upright and in an unloaded condition.

7. The device according to any one of claims 1-6, wherein the inner surface of one of the medial or lateral sides of the sole or orthotic comprising a convexly rounded portion, as viewed in a frontal plane cross-section during an unloaded, upright condition of the sole or orthotic, the convexly rounded portion of the inner surface existing with respect to a section of the sole or orthotic directly adjacent to the convexly rounded portion of the inner surface of the sole or orthotic;

the outer surface of one of the medial or lateral sides of the sole or orthotic comprising a concavely rounded portion, as viewed in a frontal plane cross-section during an unloaded, upright condition of the sole or orthotic, the concavely rounded portion of the outer surface existing with respect to a section of the sole or orthotic directly adjacent to the convexly rounded portion of the outer surface of the sole or orthotic.

8. The device according to any one of claims 1-7, wherein the rounded portion of at least one of said lateral or medial sides is uniformly thick between said inner and outer surfaces, said uniform thickness extending from a ground-contacting portion to a sidemost extent of said outer surface, as viewed in said frontal plane cross-section during an unloaded, upright condition of the sole or orthotic.

9. The device according to any one of claims 7-8, wherein said outer chamber, compartment or bladder at least partially or mostly or entirely enclosing a space within said outer chamber, compartment or bladder;

said inner chamber, compartment or bladder located inside said enclosed space of said outer chamber.

10. The device according to any one of claims 7-9, wherein said inner surface of said outer chamber, compartment or bladder substantially forming said surface of said internal sipe.

11. The device according to any one of claims 7-10, wherein at least a portion of said surfaces of said sipe are separated by a media when unloaded.

12. The device according to any one of claims 7-11, wherein at least a portion of said inner chamber, compartment or bladder is attached to an adjoining portion of said outer chamber, compartment or bladder.

13. The device according to any one of claims 7-12, further including at least two internal chambers, compartments or bladders.

14. The device according to any one of claims 7-13, wherein said at least inner chamber, compartment or bladder includes at least one internal structure.

15. The device according to any one of claims 7-14, wherein at least one said chamber, compartment, or bladder includes a media with at least one selected from a group of a gas, a liquid, a fluid, a gel, a foamed plastic and a foamed rubber.

16. The device according to any one of claims 7-15, wherein at least one said chamber, compartment or bladder includes a media with at least a combination of two selected from a group of a gas, a liquid, a fluid, a gel, a foamed plastic and a foamed rubber.

17. The device according to any one of claims 7-16, wherein at least a portion of said chamber, compartment or bladder media or said sipe media includes a magnetorheological fluid.

18. The device according to any one of claims 7-17, wherein at least one chamber, compartment or bladder comprises fiber.
19. The device according to any one of claims 7-18, wherein at least one said inner chamber, compartment or bladder includes a structural element made of one selected from a group of a foamed plastic and a material the same as that of said inner chamber.
20. The device according to any one of claims 7-19, wherein at least one said inner chamber, compartment or bladder is located in an instep area of the shoe sole between the heel area and the forefoot area; and includes a flexible shank.
21. The device according to any one of claims 7-20, wherein at least a portion of the outer surface of the outer chamber, compartment or bladder is the outer surface of at least one selected from a group of the footwear sole, footwear upper, orthotic, orthotic upper, and other product.
22. The device according to any one of claims 7-21, wherein at least one said inner chamber, compartment or bladder includes at least one component selected from a group of mechanical, electromechanical, electronic, and microprocessor components.
23. The device according to any one of claims 7-22, wherein an outer surface of at least one said inner chamber, compartment or bladder is formed from a foamed plastic.
24. The device according to any one of claims 7-23, wherein said at least one inner chamber, compartment or bladder has a thickness measured about vertically or horizontally that is nearly the same but somewhat less than said outer chamber.
25. The device according to any one of claims 7-24, wherein said footwear sole or orthotic has a thickness which is one selected from a group of

greater in the heel area than in the forefoot area, greater in the forefoot area than in the heel area, and about equal in both the forefoot and heel area.

26. The device according to any one of claims 7-25, wherein said footwear sole or orthotic has a uniform radial thickness between a lateral extent of each side, when measured in a frontal plane cross-section in an upright, unloaded condition, exclusive of insole or sockliner and upper.

27. The device according to any one of claims 1-26, wherein said footwear sole or orthotic or other product is substantially made of a firm or hard midsole material that is on a Shore A Hardness Scale at least 60 durometers or at least 65 durometers or at least 75 durometers or at least 80 durometers or at least 85 durometers or at least 90 durometers or at least 95 durometers or 100 durometers.

28. The device according to any one of claims 1-27, wherein said footwear sole or orthotic or other product is substantially made of a firm or hard midsole material that is on a Shore D Hardness Scale at least 20 durometers or at least 30 durometers or at least 40 durometers or at least 50 durometers or at least 60 durometers or at least 70 durometers or at least 80 durometers or at least 90 durometers.

29. The device according to any one of claims 1-28, wherein said footwear sole or orthotic or other product is substantially made of a firm or hard midsole material that is on the Asker C Hardness Scale greater than 70 durometers or over 75 durometers or over 80 durometers or over 85 durometers or over 90 durometers or over 95 durometers.

30. The device according to any one of claims 1-29, wherein said footwear sole or orthotic or other product is substantially made of a firm or hard midsole material that has reduced foam compared to the art or no foam.

31. The device according to any one of claims 1-30, wherein said footwear sole or orthotic or other product is substantially made of a firm or hard

midsole material that has reduced gas compared to the art or no gas.

32. The device according to any one of claims 1-31, wherein said footwear sole or orthotic or other product is substantially made of a firm or hard midsole material that has reduced number or size of cells compared to the art or no cells.

33. The device according to any one of claims 1-32, wherein said footwear sole or orthotic or other product is substantially made of a firm or hard midsole material that has reduced compression compared to the art or no compression.

34. The device according to any one of claims 1-33, wherein said footwear sole or orthotic or other product is substantially made of a firm or hard midsole material that has increased flexibility compared to the art in terms of flexural modulus.

35. The device according to any one of claims 1-34, wherein said footwear sole or orthotic or other product is substantially made of a firm or hard midsole material that comprises fiber.

36. The device according to any one of claims 1-35, wherein said footwear sole or orthotic or other product comprises a multitude of ball bearings located within the internal side or the inner compartment.

37. The device according to any one of claims 1-36, wherein a midsole portion of said sole or orthotic is removeable or insertable.

38. The device according to any one of claims 1-37, the sole or orthotic includes a computer.

39. A device for a footwear sole or footwear upper or both, or an orthotic or orthotic upper or both, or another product, including:

a unitary compartment, chamber, or bladder insert comprising at least an internal slit,

said internal slit has opposing surfaces that are separate from each other and therefore can move relative to each other, and at least a portion of one of said opposing surfaces that can move relative to each other is in contact in an unloaded condition with a portion of the other of said opposing surfaces that can move relative to each other.

40. The device according to claim 39, wherein said opposing surfaces of said internal slit are substantially in contact with each other in a unloaded condition.

41. The device according to any one of claims 39-40, wherein said opposing surfaces of said internal slit are substantially in contact with each other in a loaded condition.

42. The device according to any one of claims 39-41, wherein said opposing surfaces of said internal slit are separated by a thin layer of liquid or gel media when unloaded.

43. The device according to any one of claims 39-42, wherein said opposing surfaces of said internal slit are separated by a thin layer of liquid or gel media when loaded.

44. A device, including:
an outer chamber;
at least one inner chamber inside said outer chamber;
said outer chamber and said inner chamber being separated at least in part by an internal sipe; and
at least a portion of a surface of said outer chamber forming at least a portion of a surface of said internal sipe.

45. The device of claim 44, wherein the outer chamber is located within a footwear sole.

45. The device of claim 44, wherein the outer chamber is located within an artificial spinal disc.

46. The device of claim 44, wherein the outer chamber is located within one of a tire, glove, apparel, furniture, bedding, architectural component, cable, body brace, transportation vehicle element, tennis racquet, golf club, ball, semiconductor microchip, or computer component.

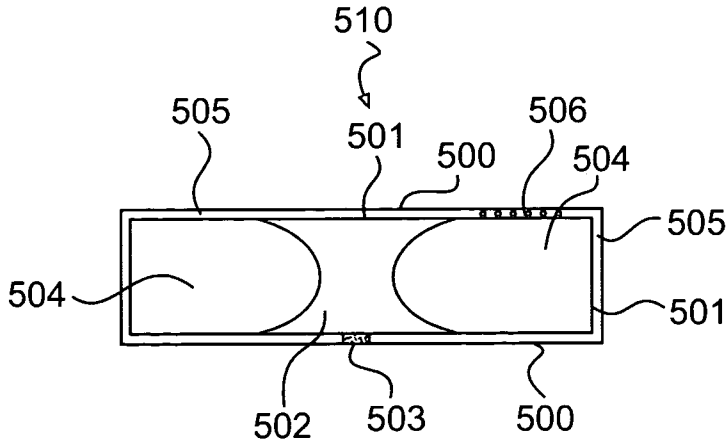

FIG. 1A

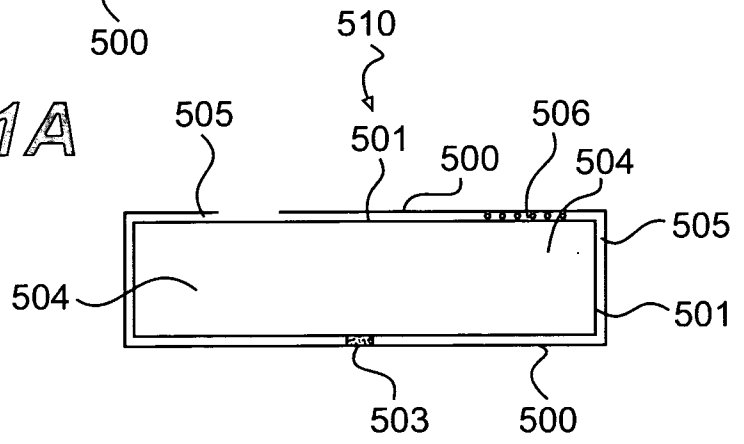

FIG. 2A

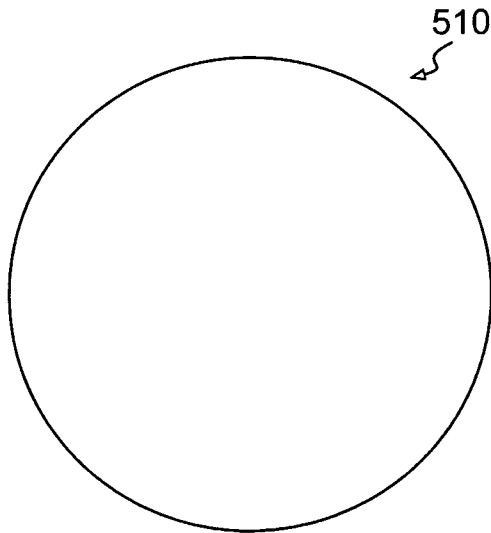

FIG. 1B

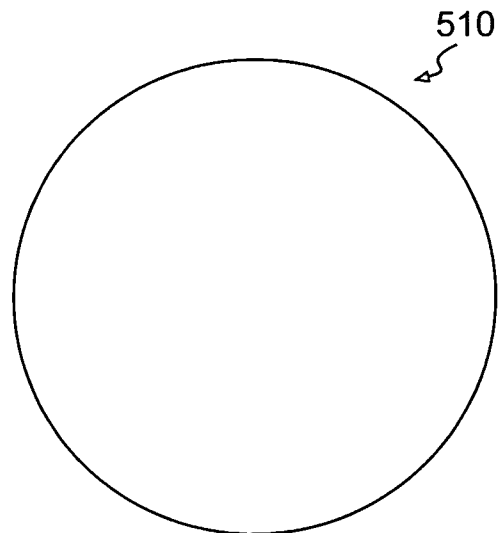

FIG. 2B

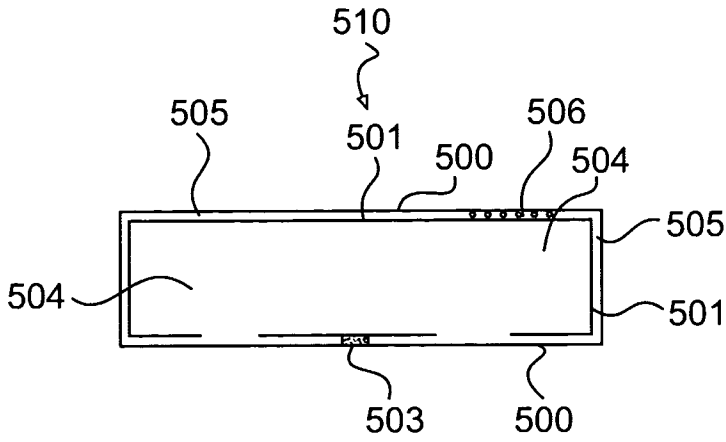

FIG. 3A

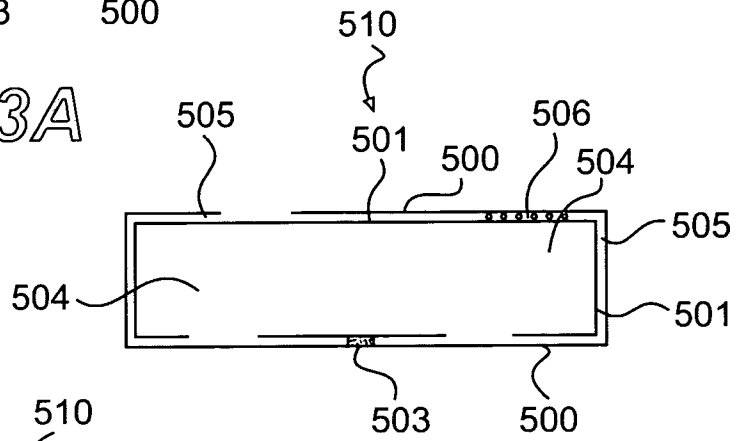

FIG. 4A

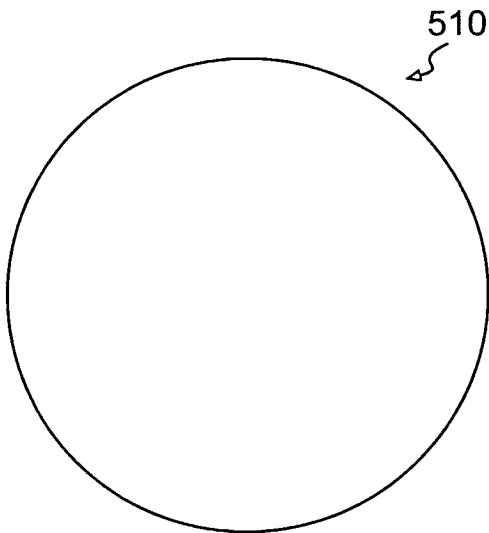

FIG. 3B

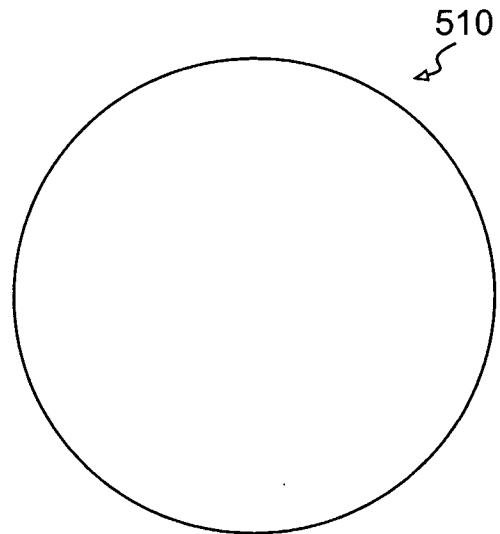

FIG. 4B

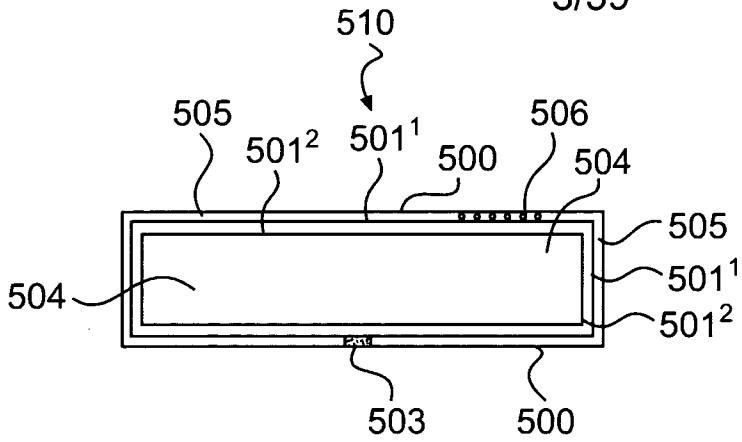

FIG. 5A

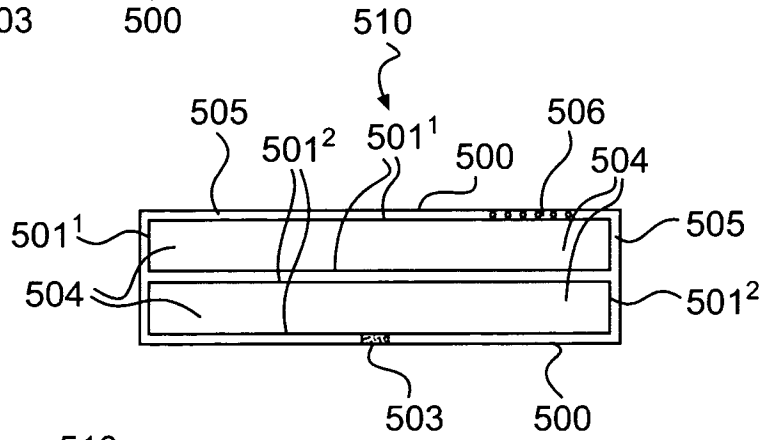

FIG. 6A

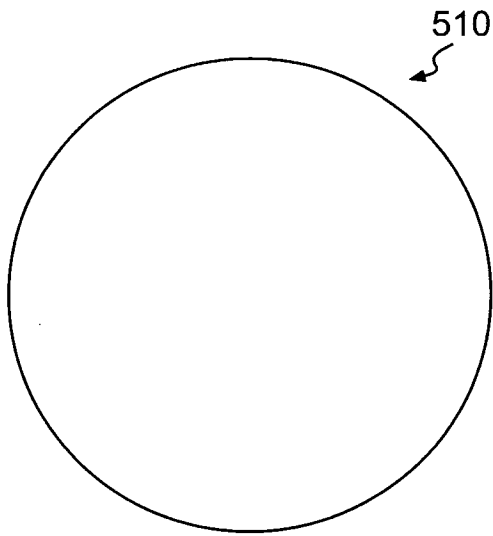

FIG. 5B

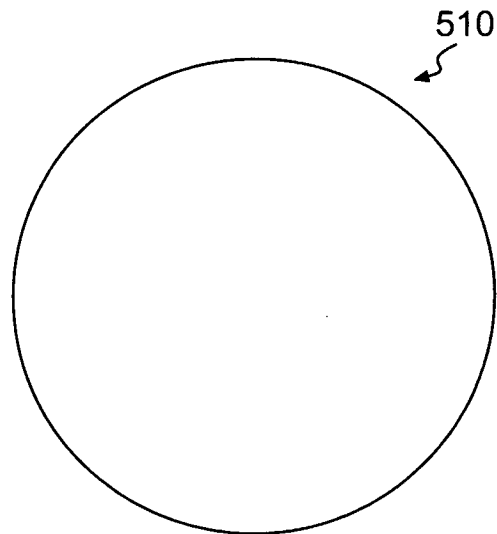

FIG. 6B

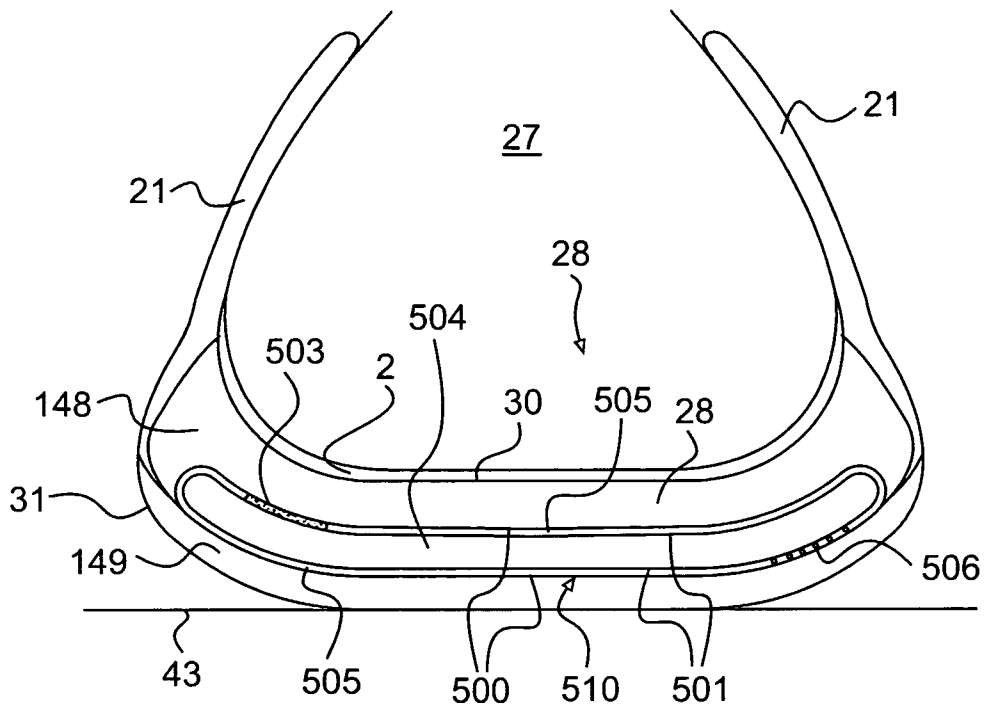

FIG. 7

5/59

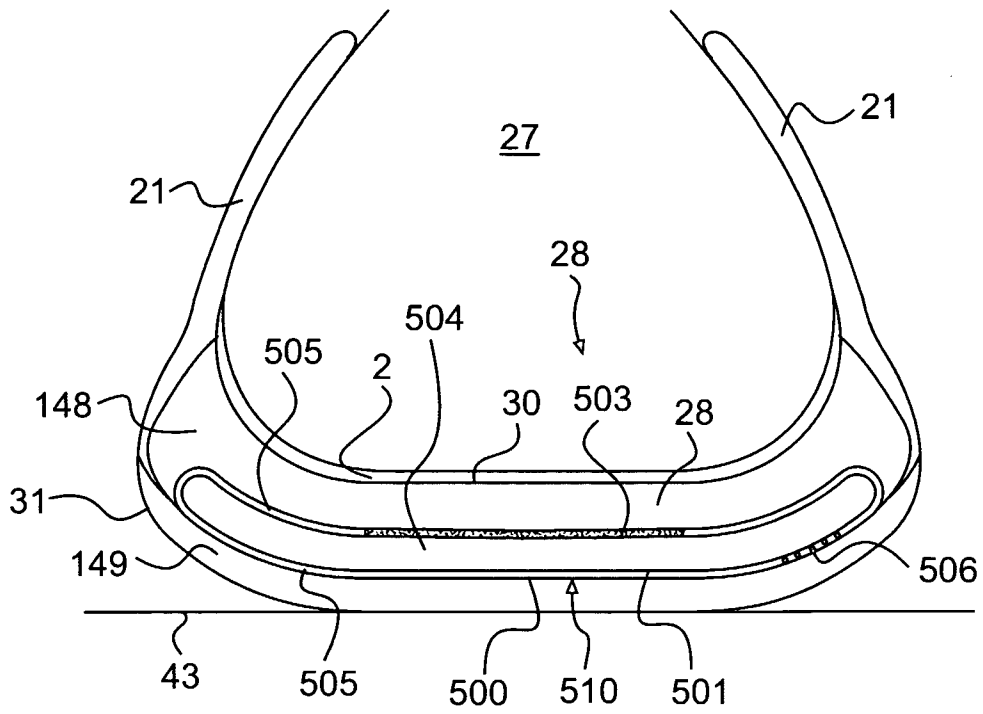

FIG. 8

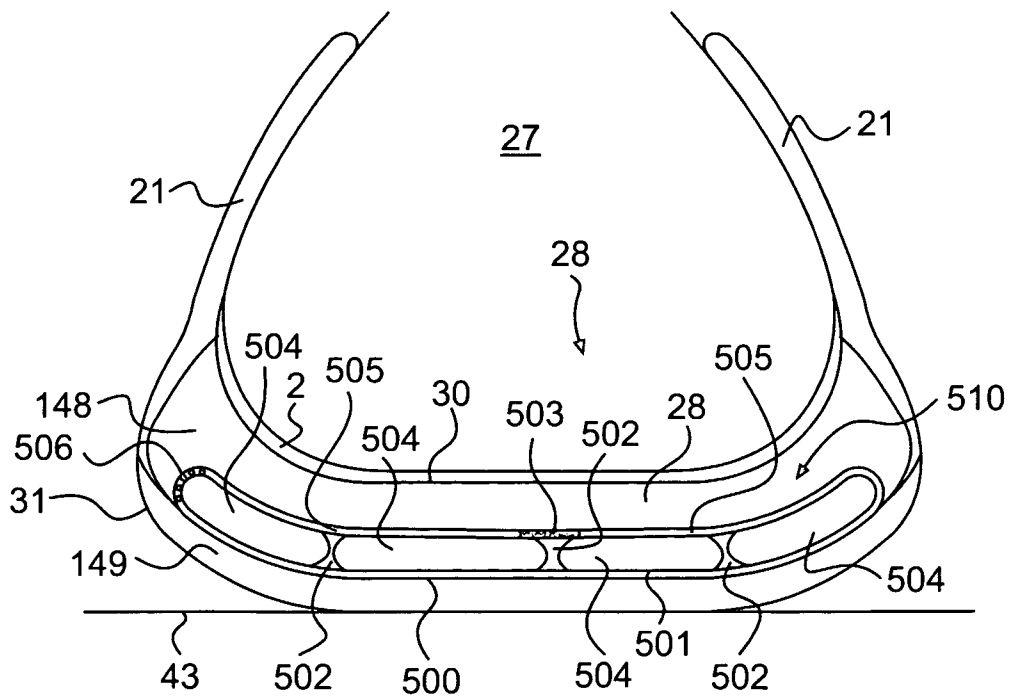

FIG. 9

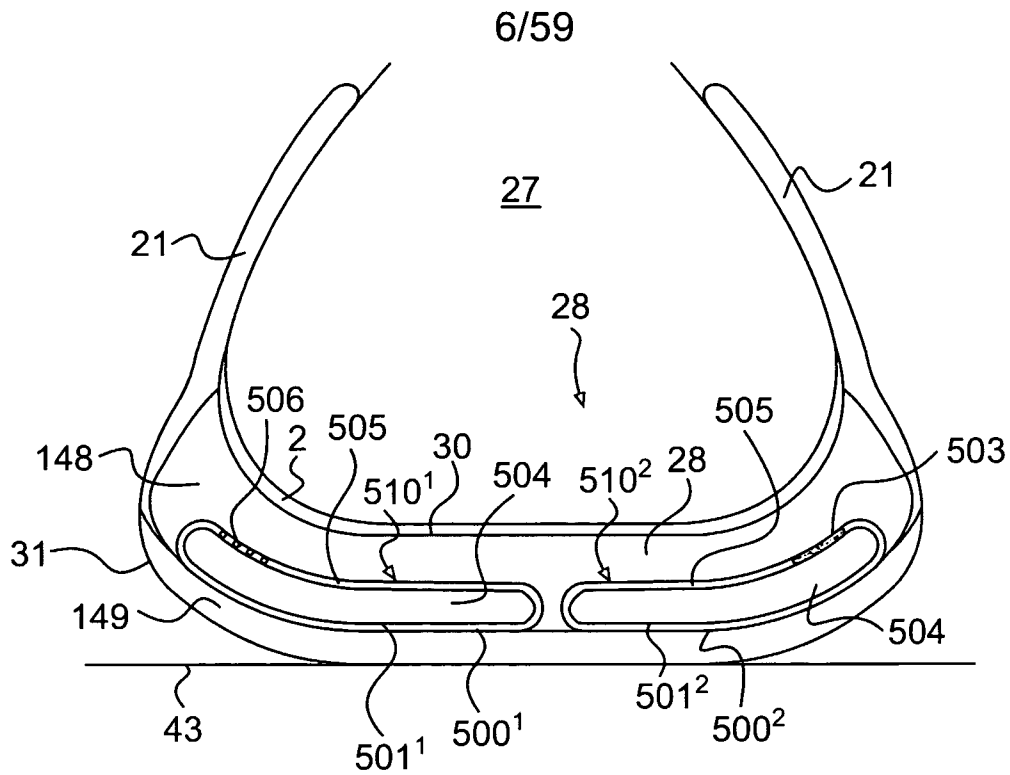

FIG. 10

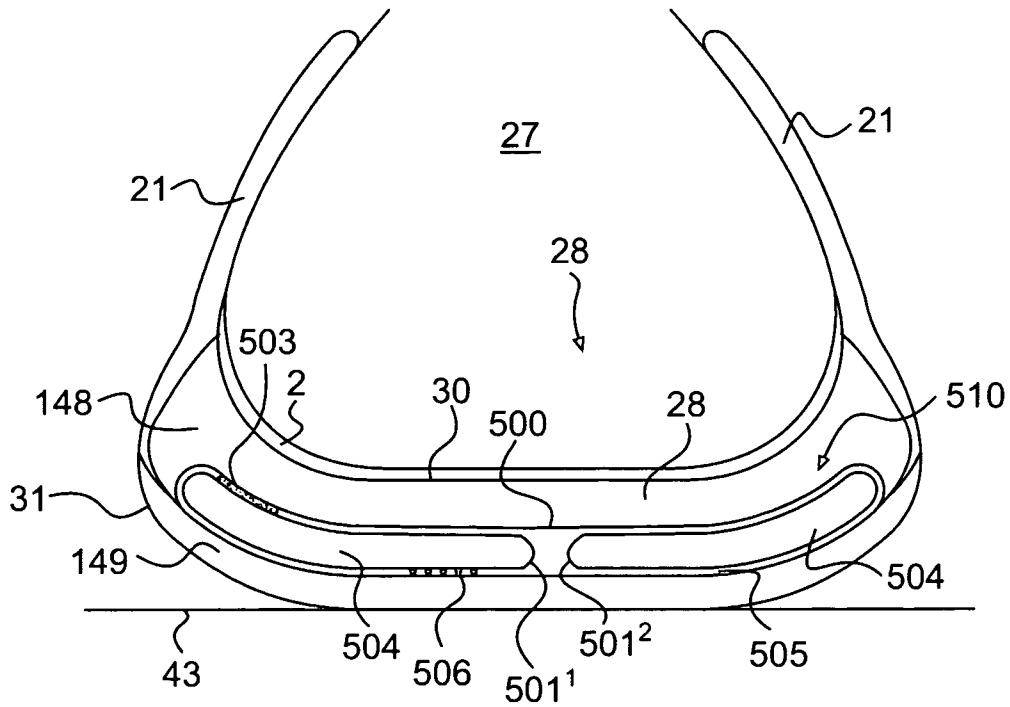

FIG. 11

7/59

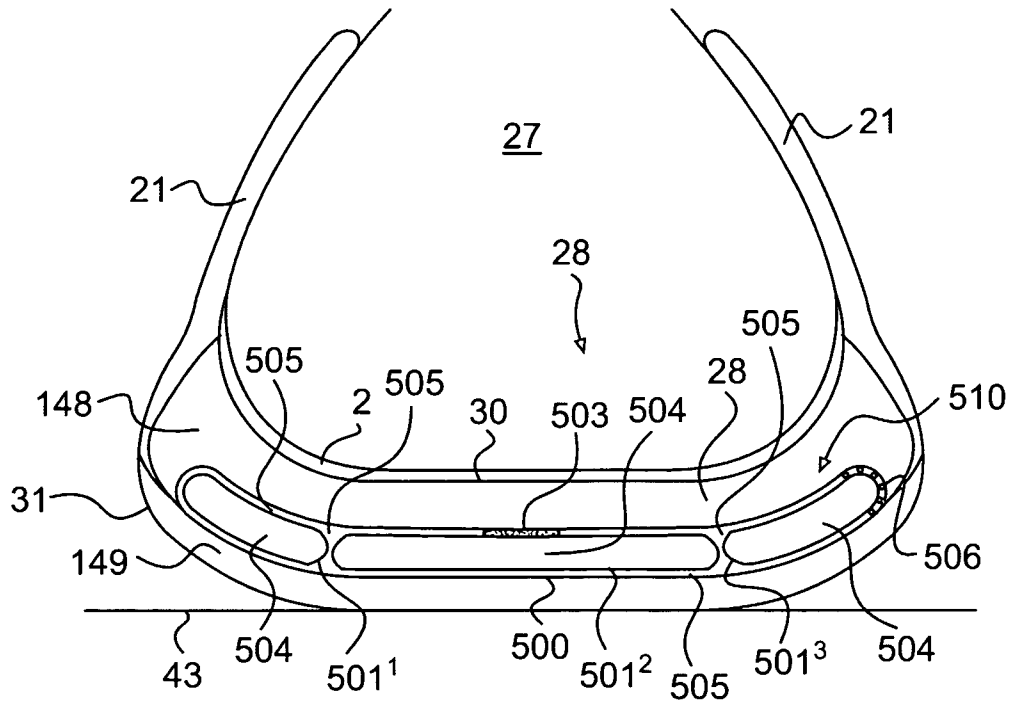

FIG. 12

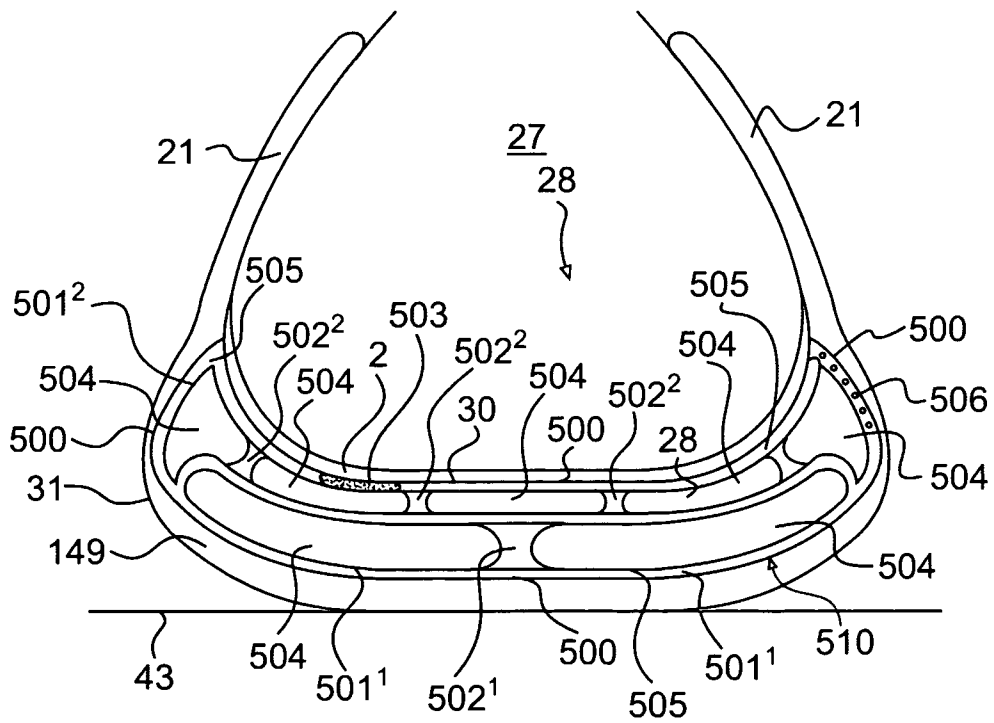

FIG. 13

8/59

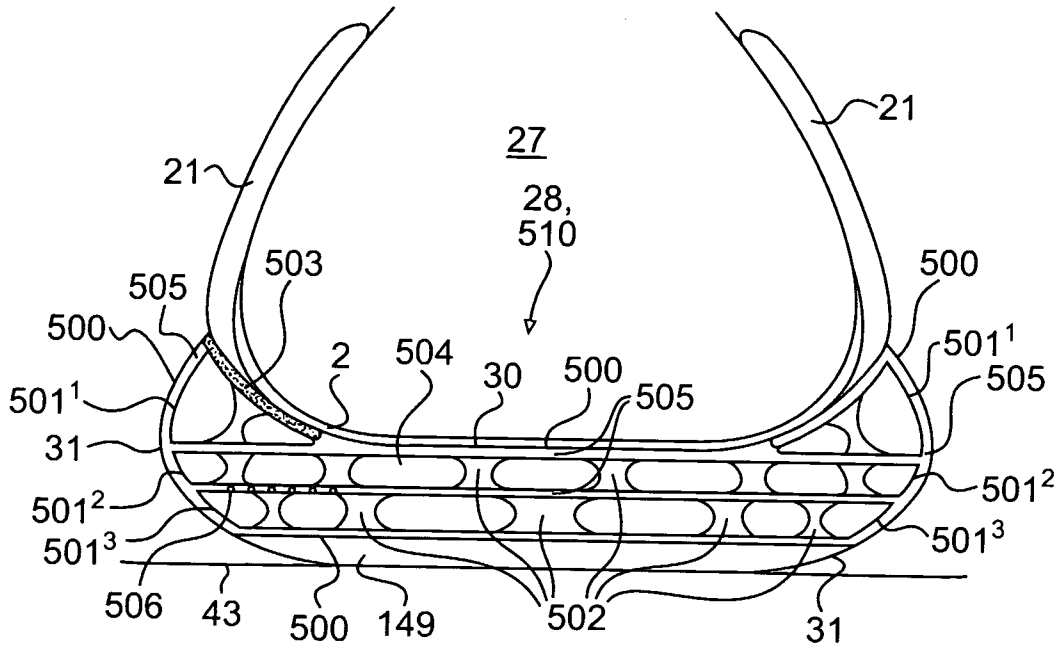

FIG. 14

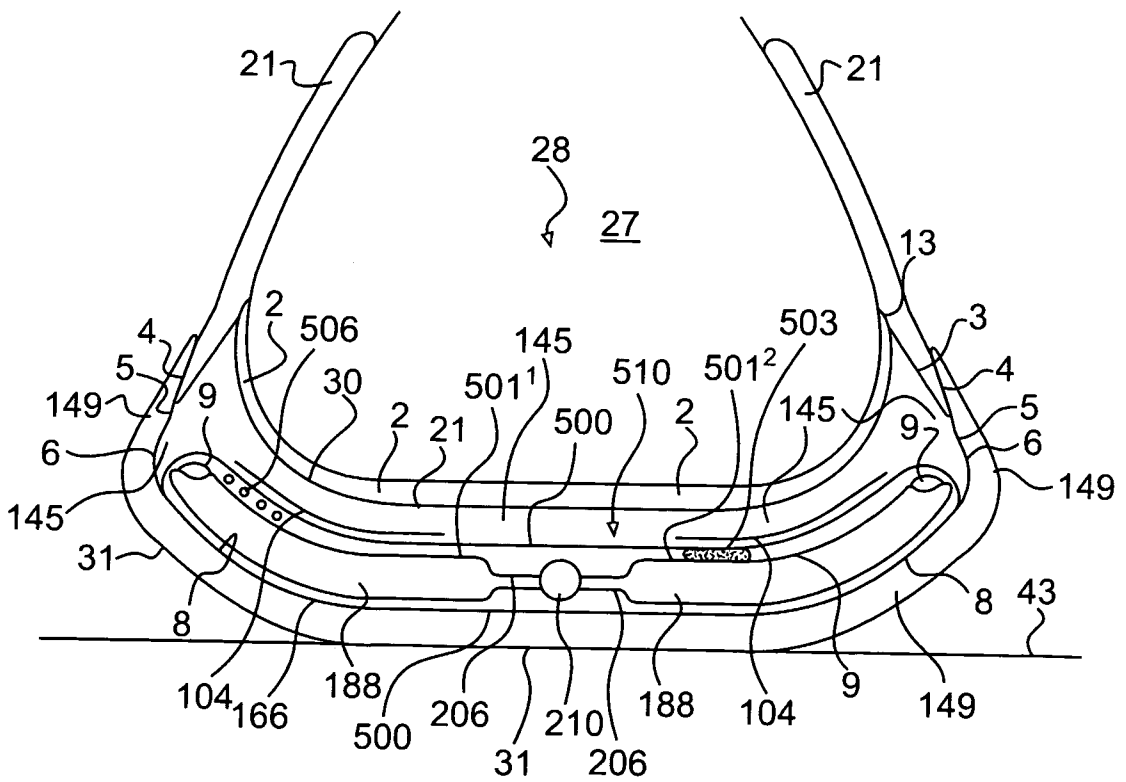

FIG. 15

9/59

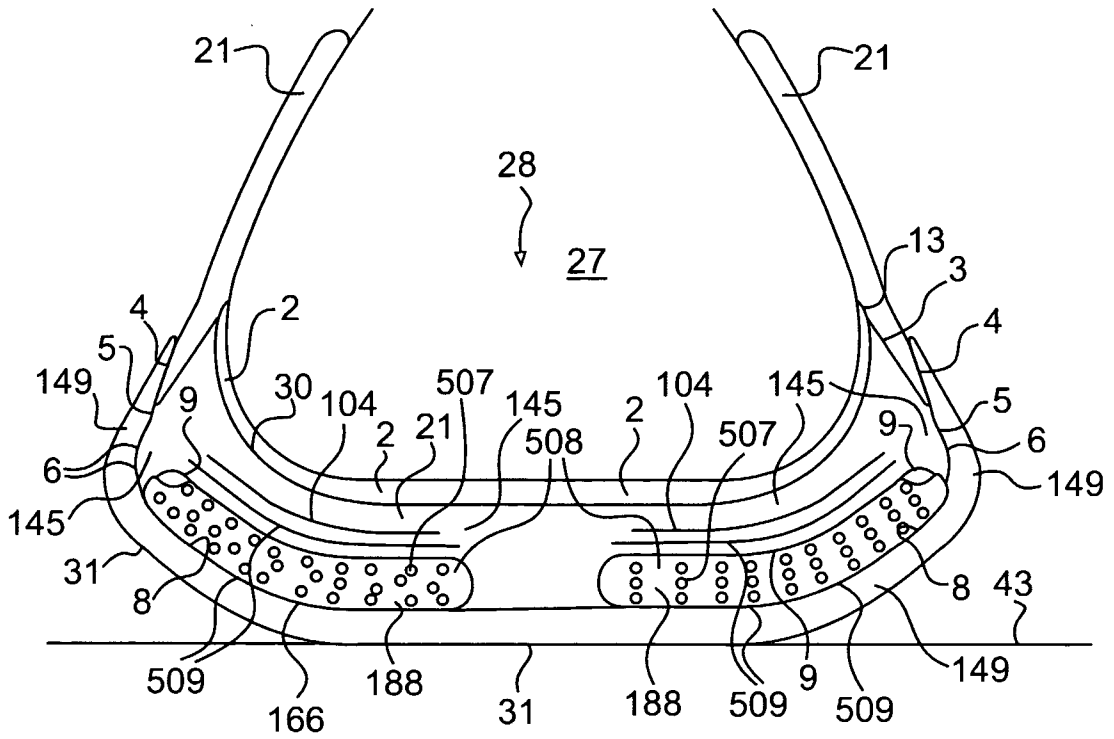

FIG. 16

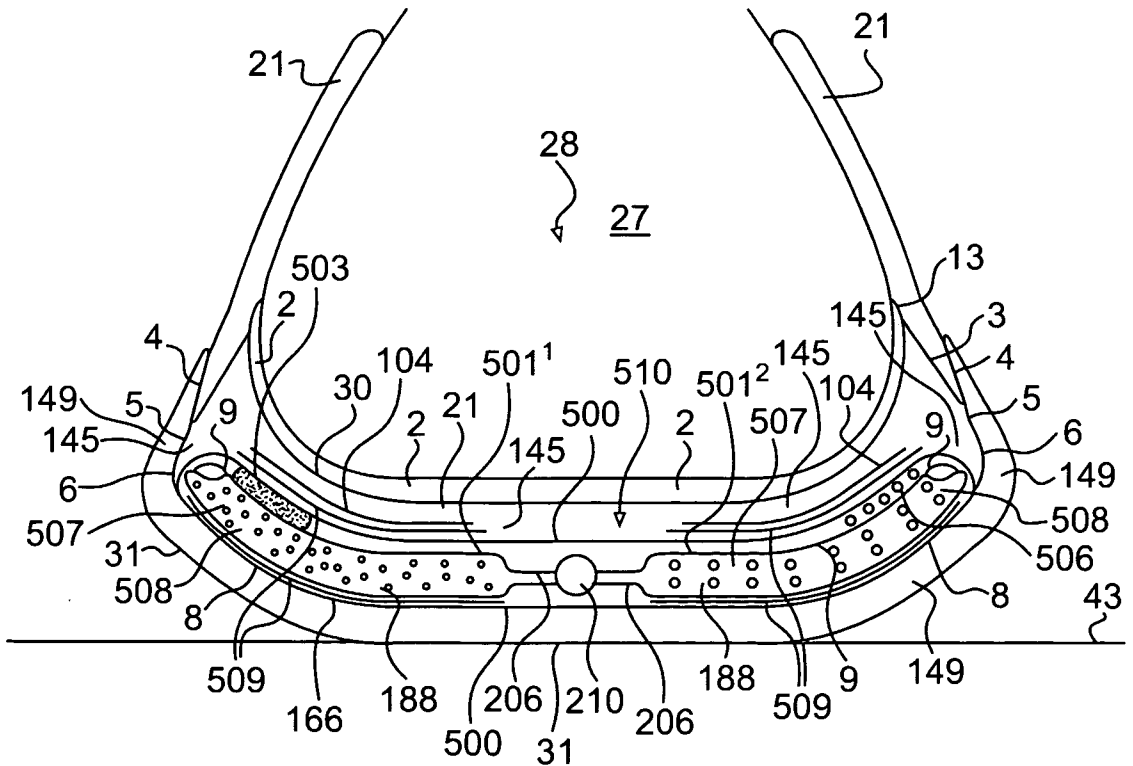

FIG. 17A

SUBSTITUTE SHEET (RULE 26)

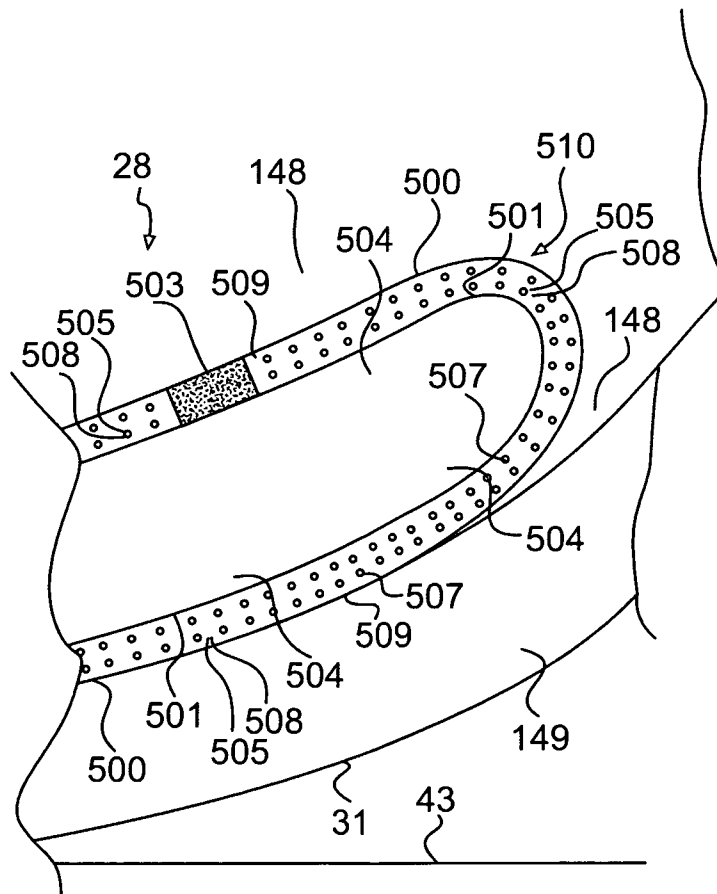

FIG. 17B

11/59

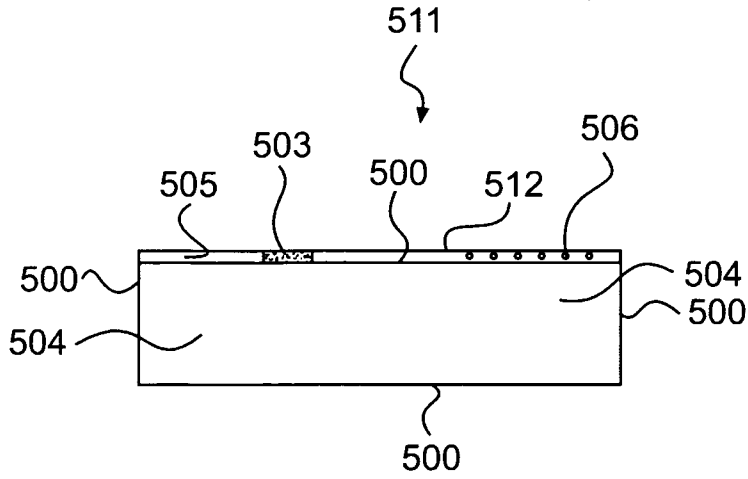

FIG. 18A

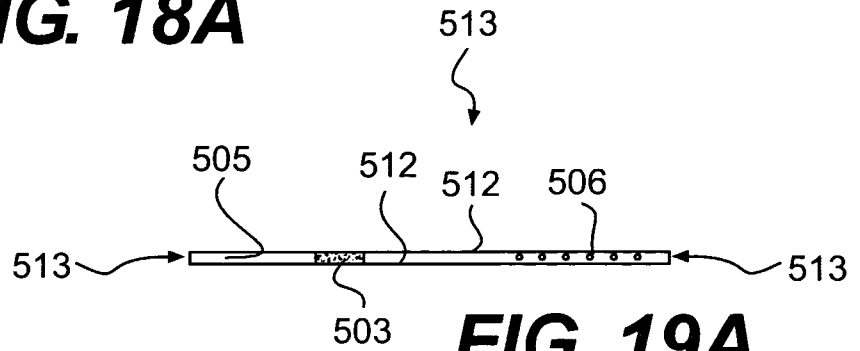

FIG. 19A

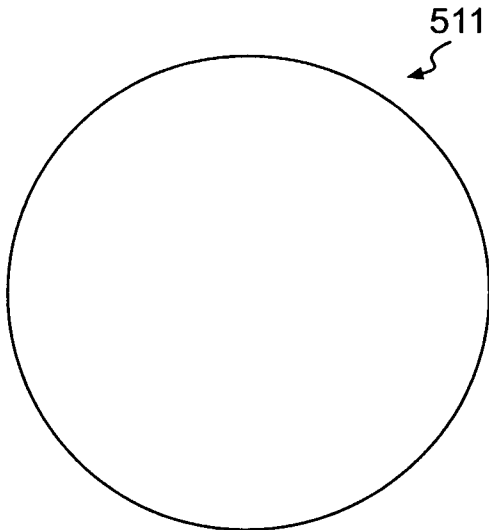

FIG. 18B

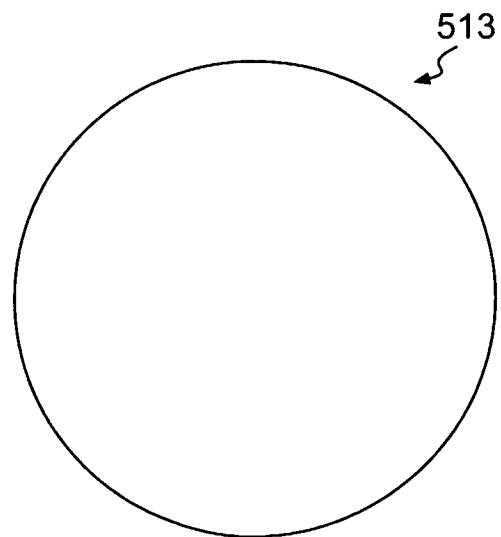
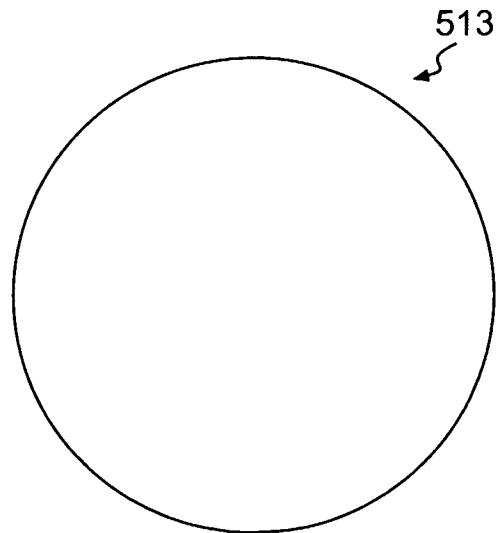
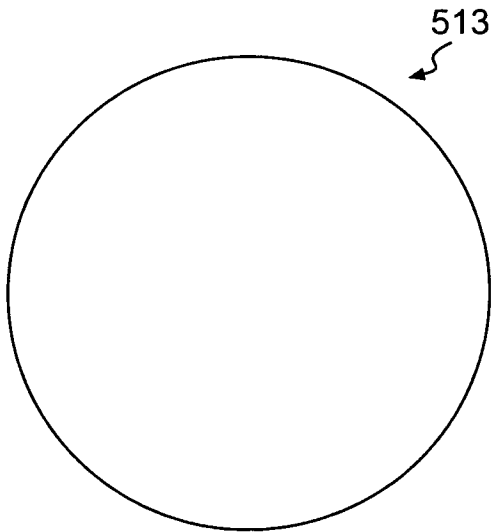
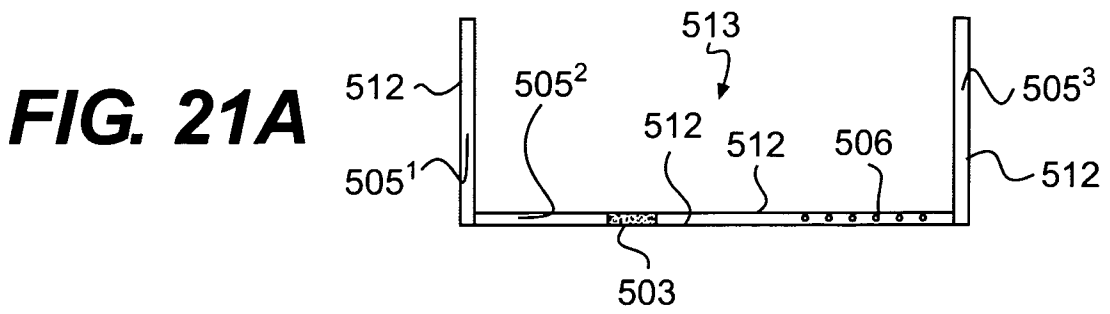
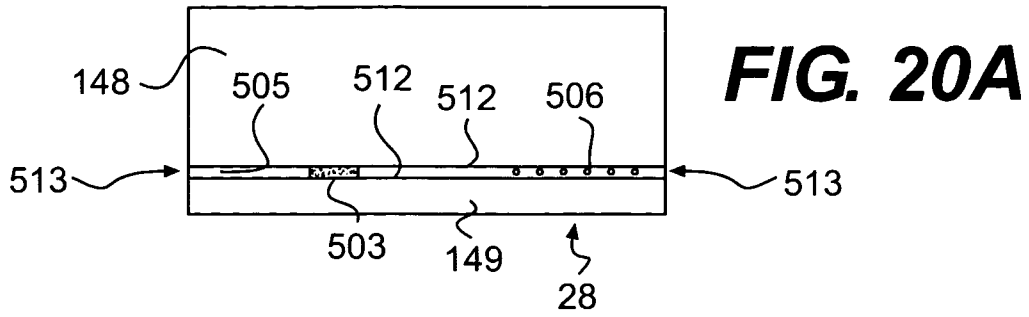

FIG. 19B

12/59



14/59

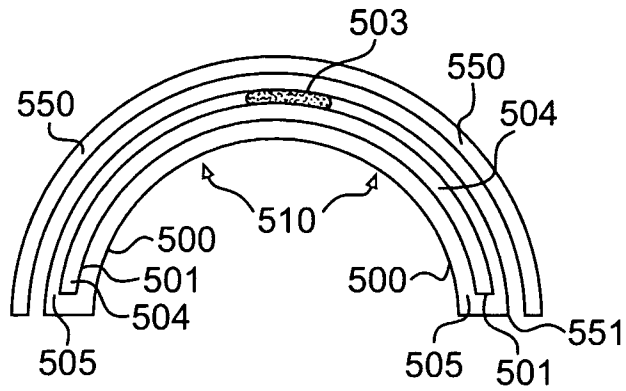

FIG. 24A

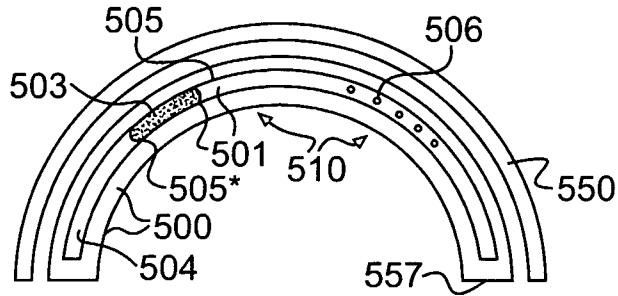

FIG. 24B

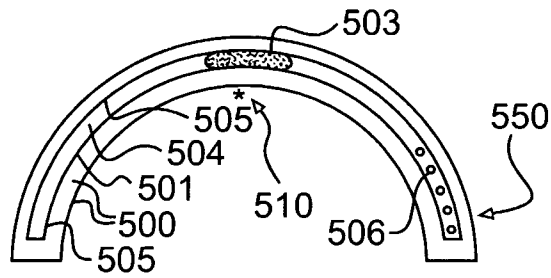

FIG. 24C

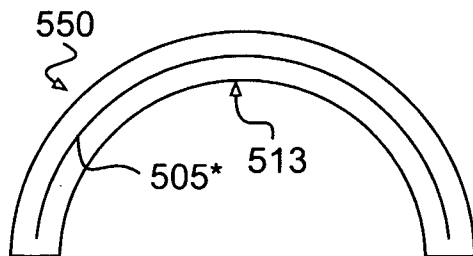

FIG. 24D

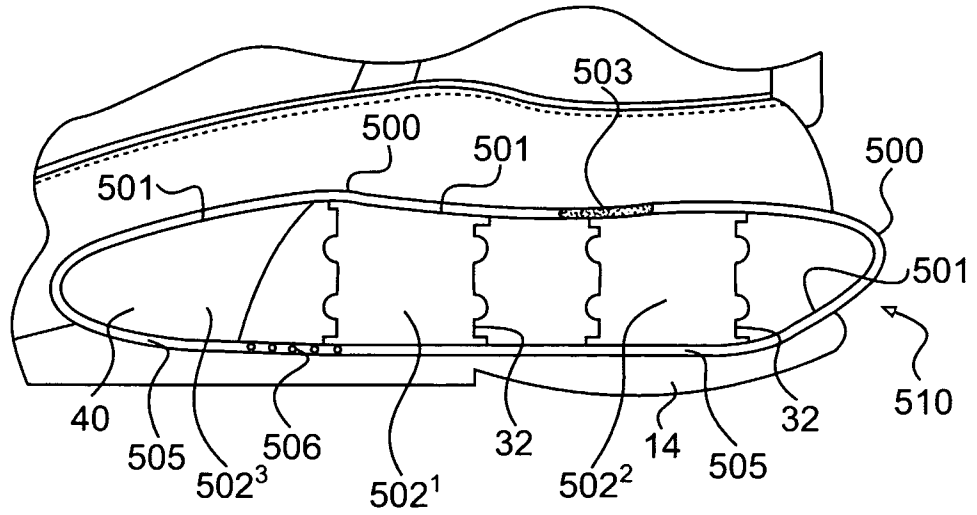

FIG. 25A

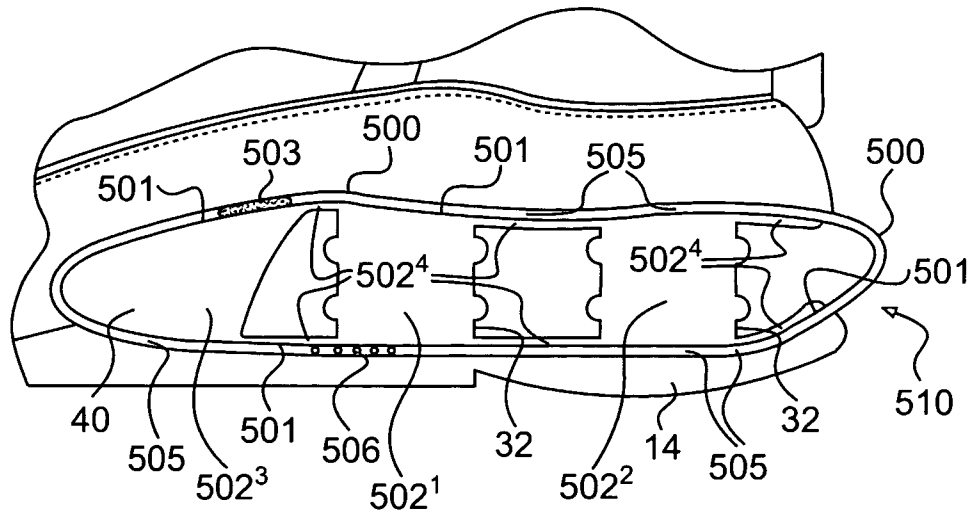

FIG. 25B

FIG. 26A

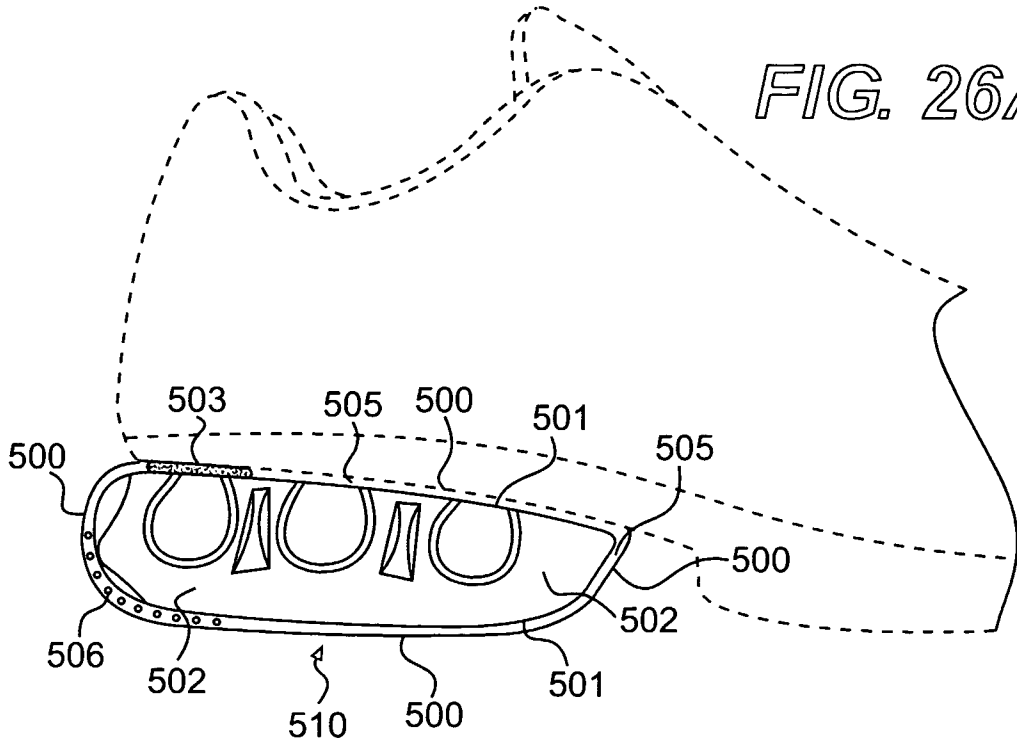
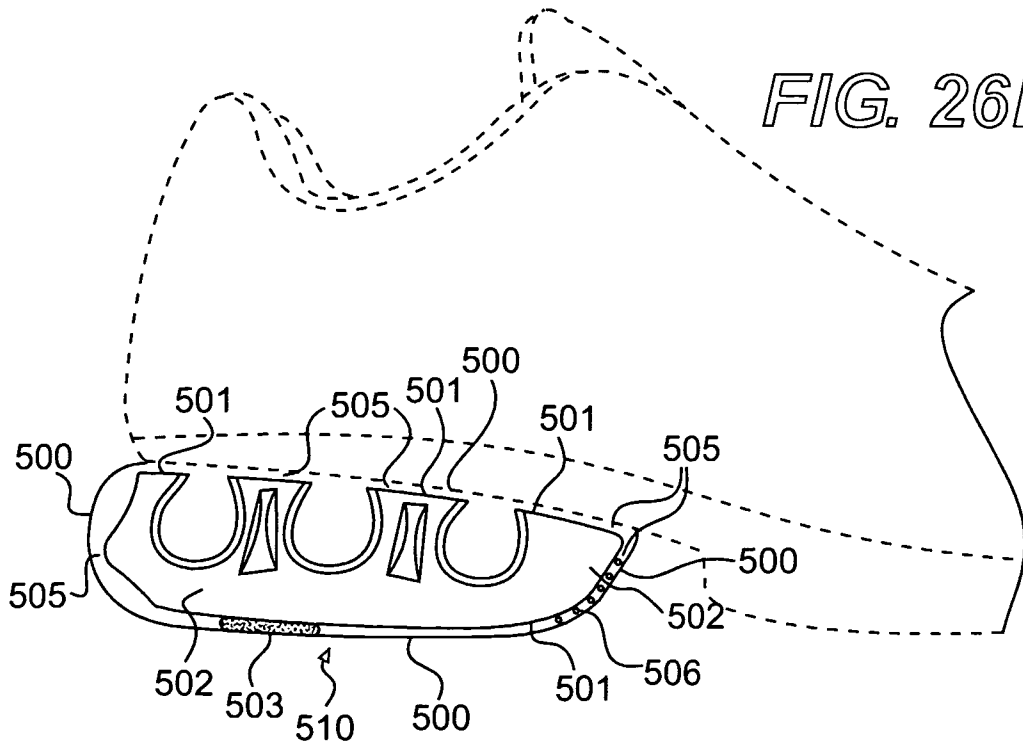

FIG. 26B



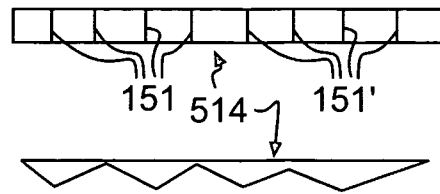

FIG. 26D

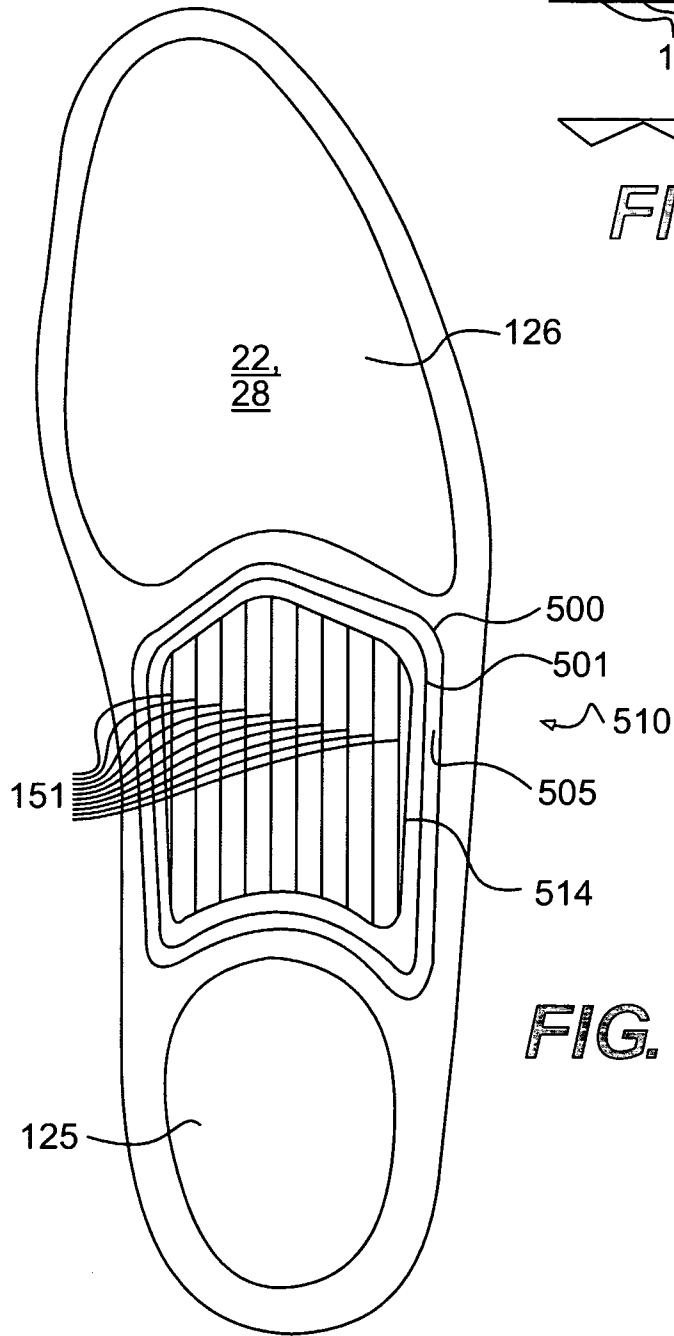

FIG. 26C

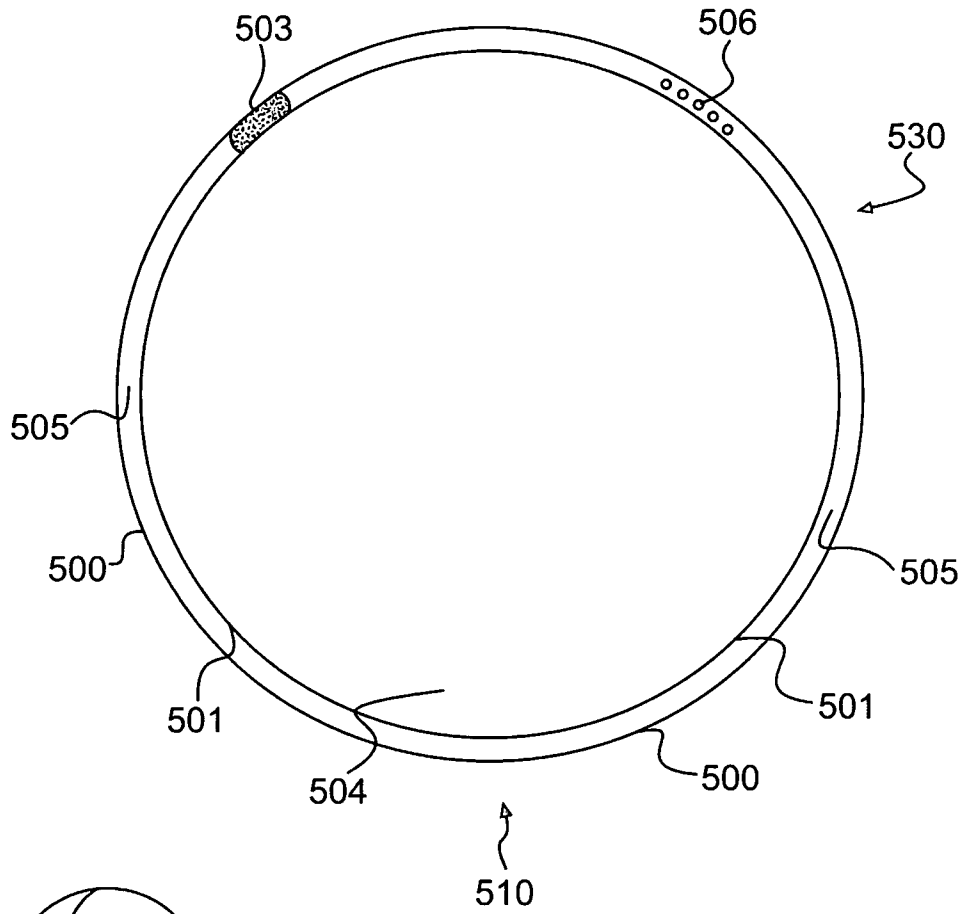

FIG. 27A

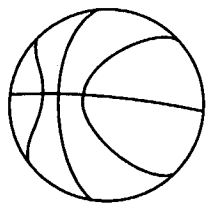

FIG. 27B
PRIOR ART

19/59

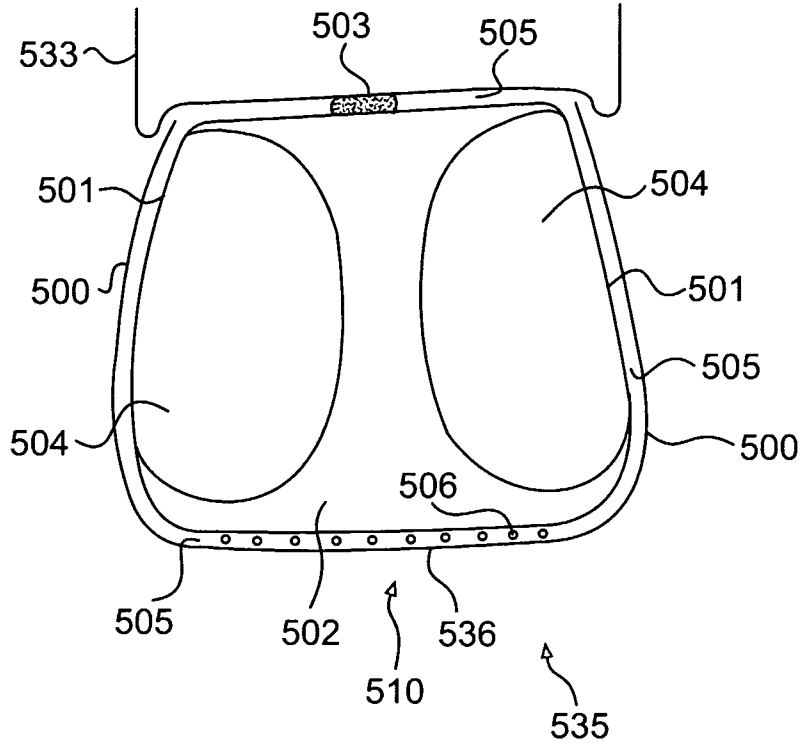

FIG. 28A

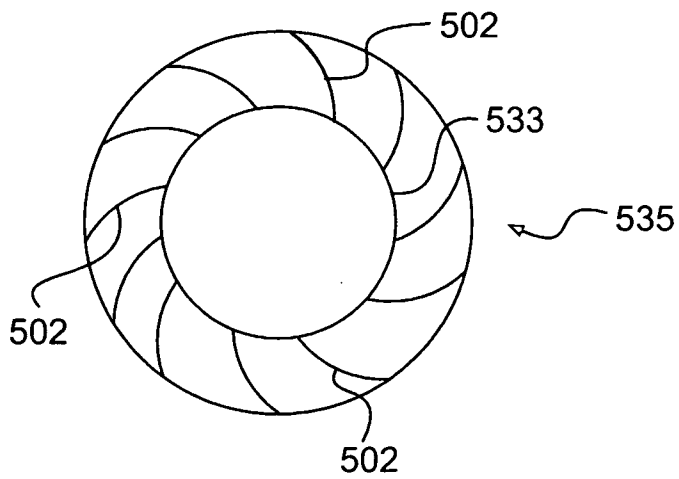

FIG. 28B

20/59

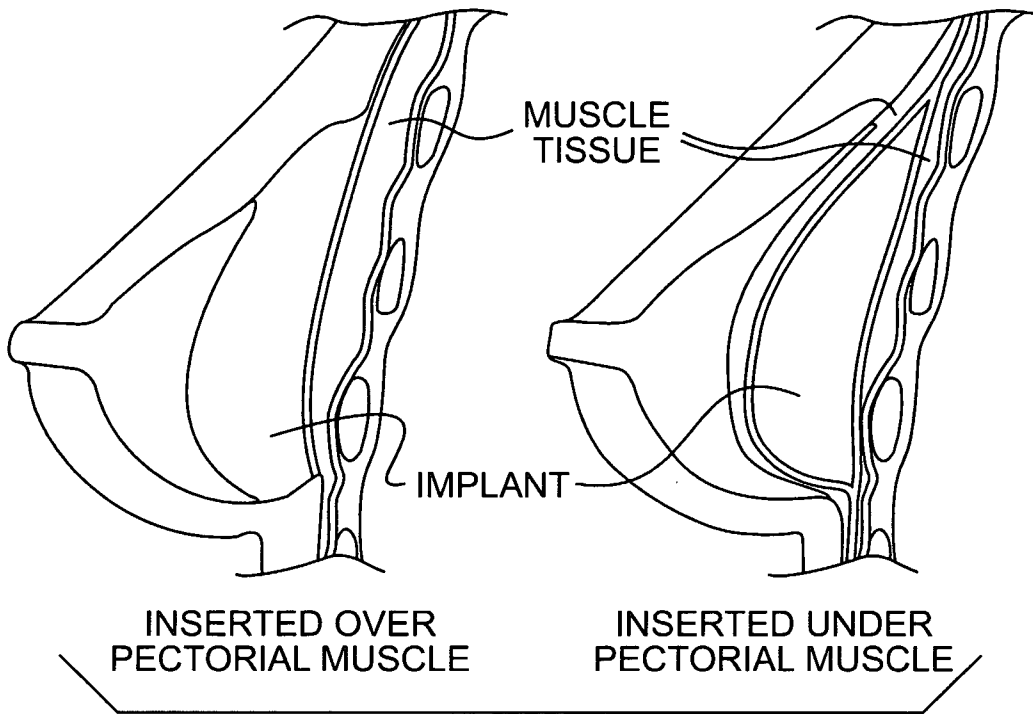

FIG. 29A
PRIOR ART

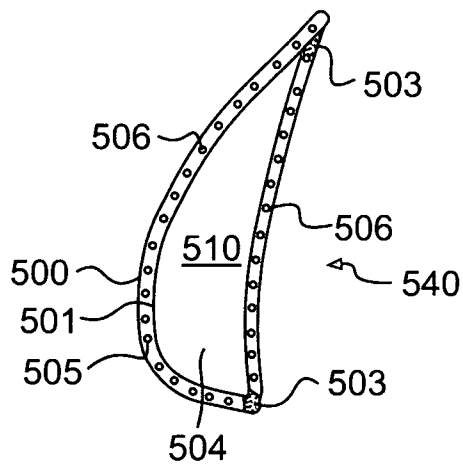

FIG. 29B

FIG. 30A

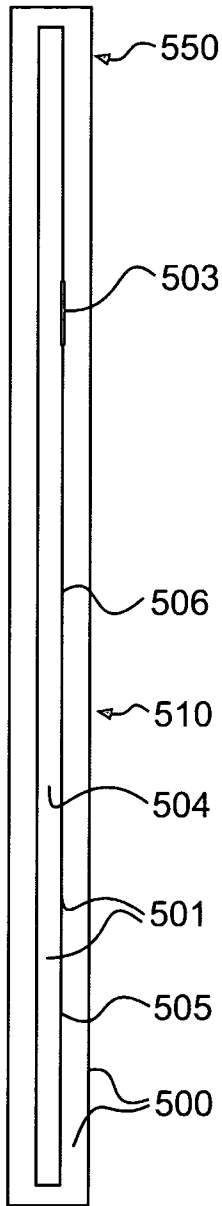

FIG. 30B

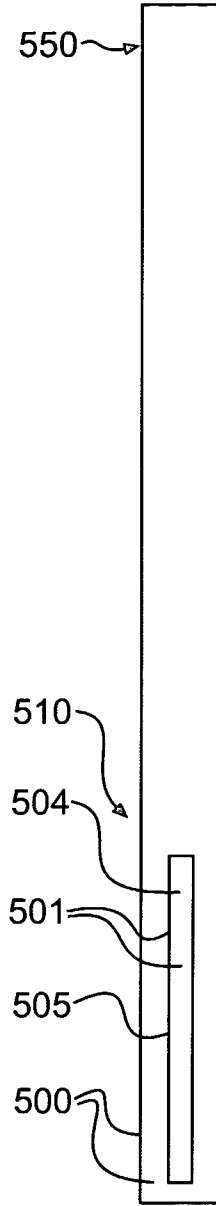

FIG. 30C

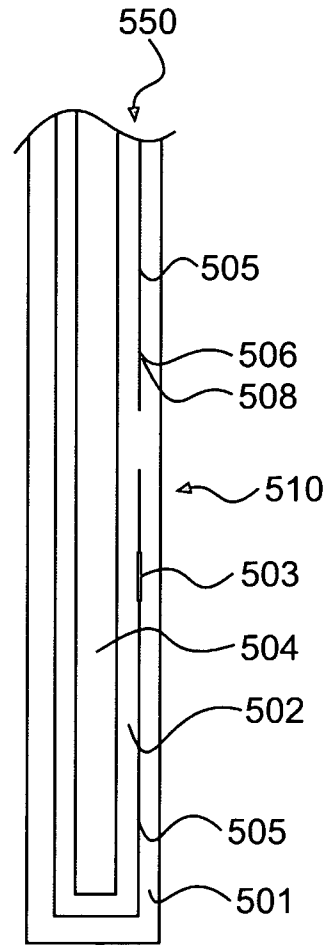

FIG. 31A
PRIOR ART

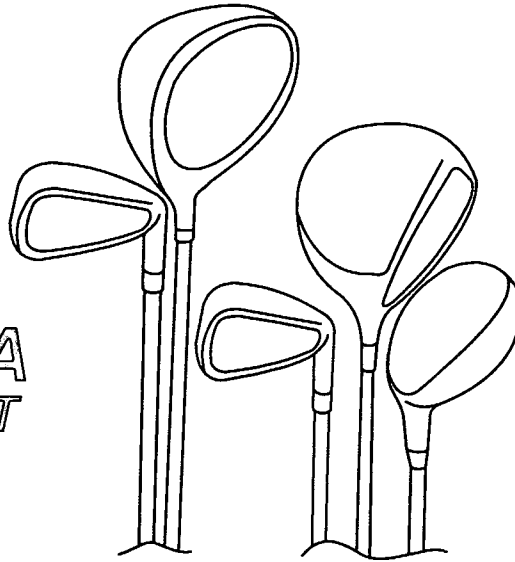
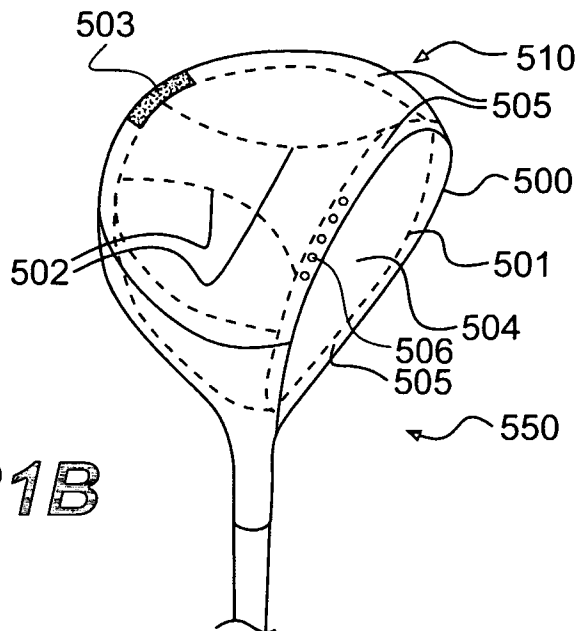

FIG. 31B



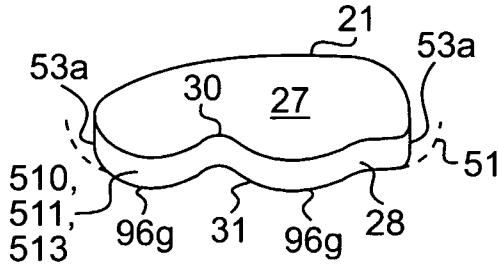

FIG. 33A

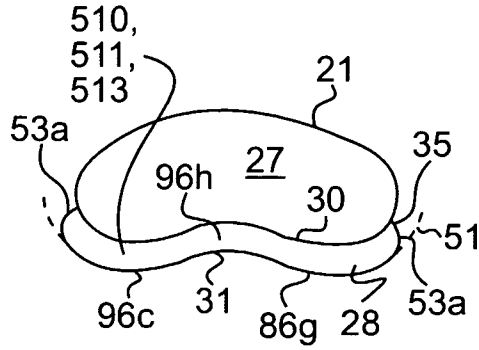

FIG. 33B

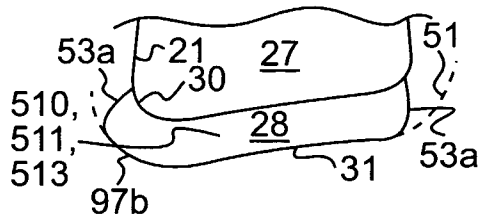

FIG. 33C

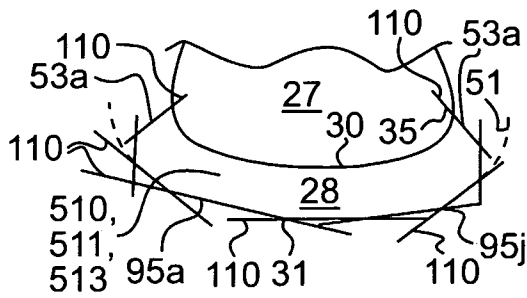

FIG. 33D

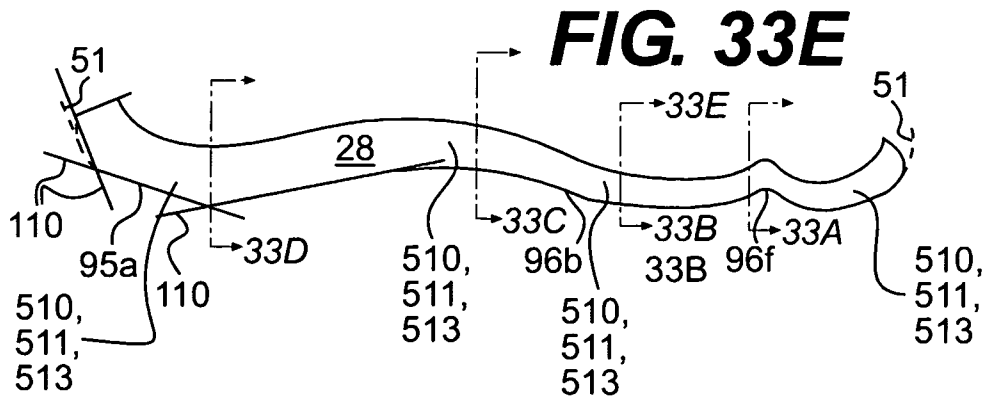

FIG. 33E

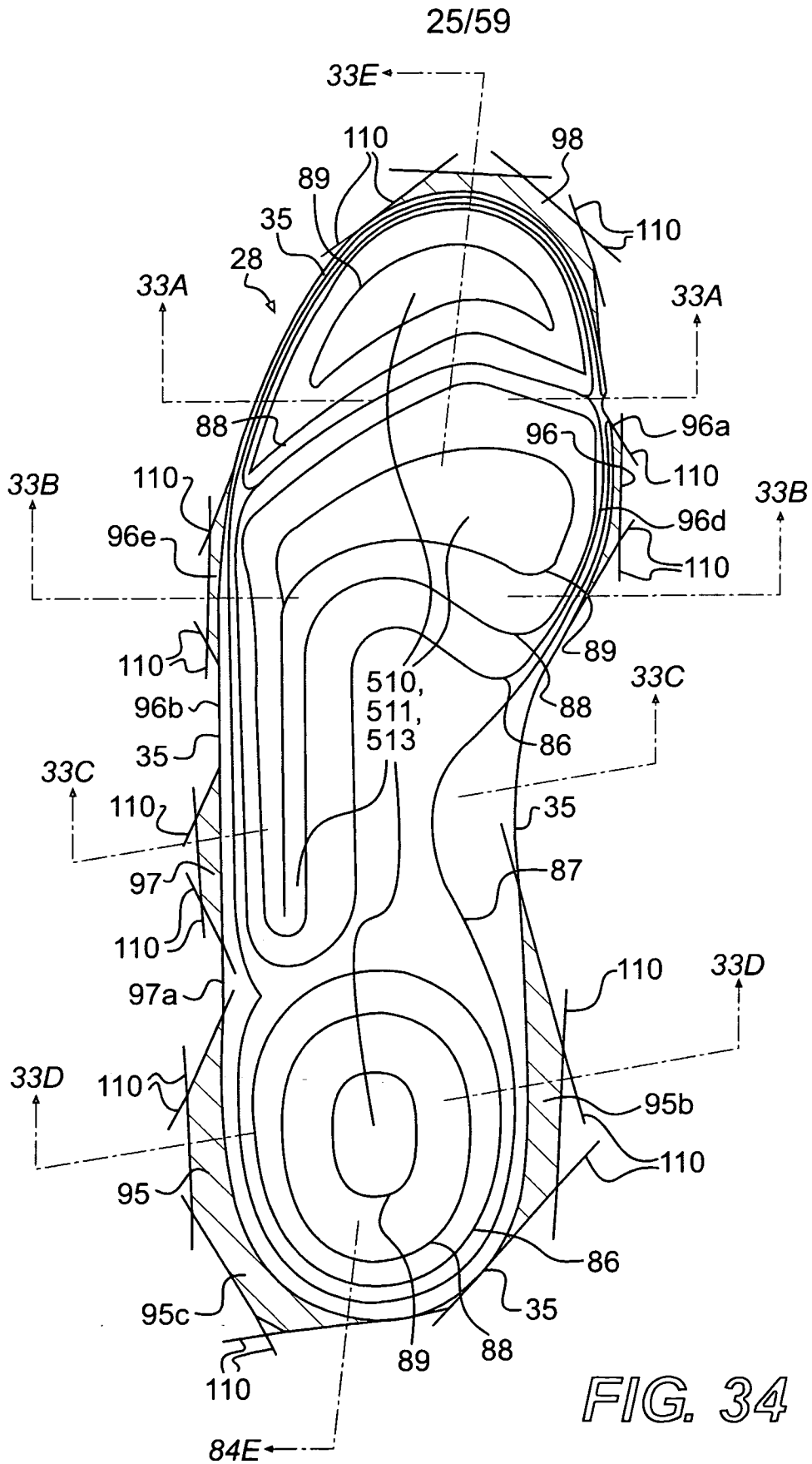

FIG. 34

26/59

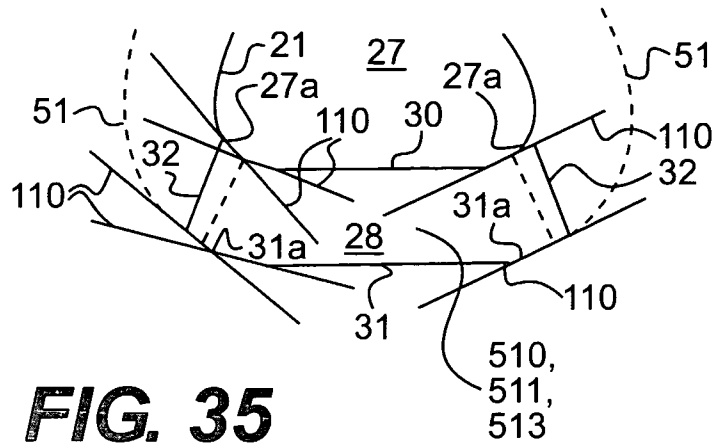

FIG. 35

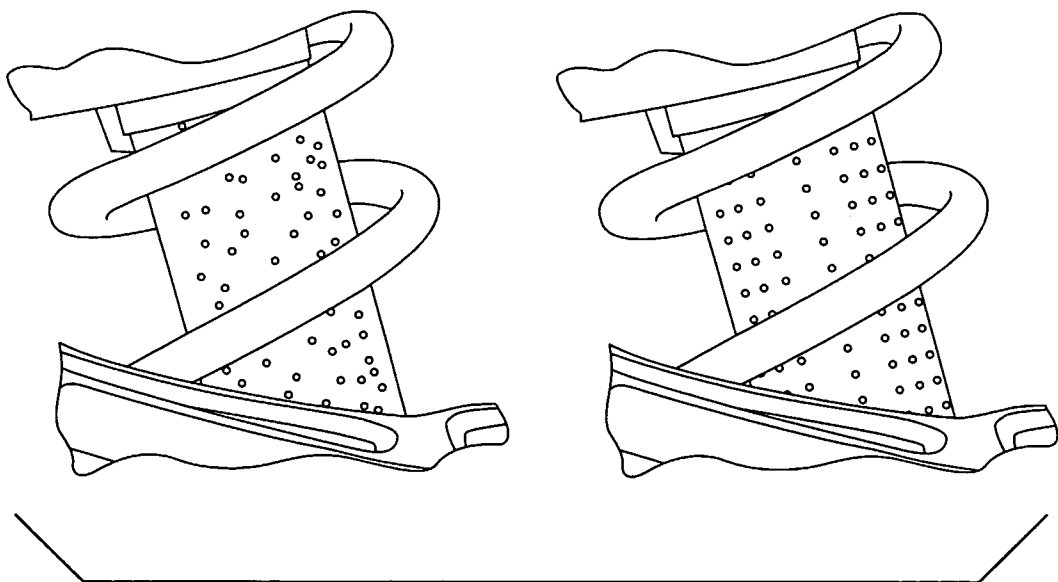

FIG. 36
PRIOR ART

27/59

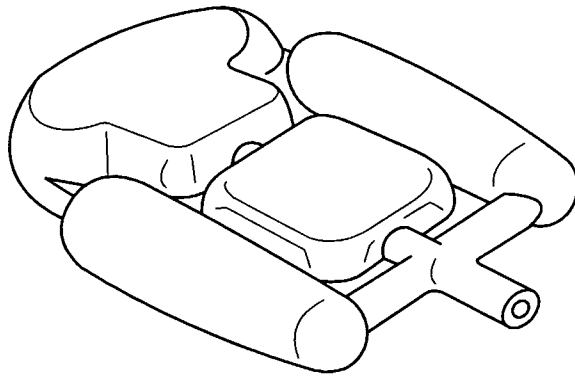

FIG. 37
PRIOR ART

FIG. 38
PRIOR ART

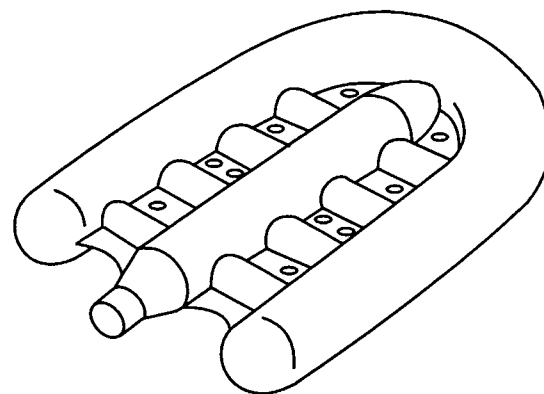
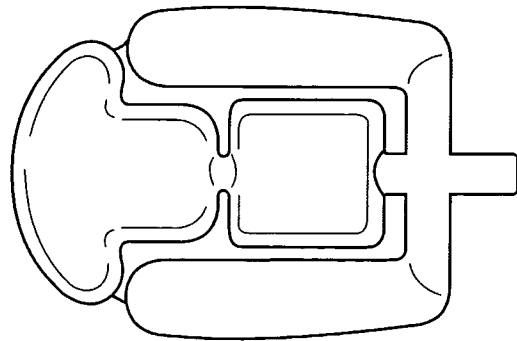

FIG. 39
PRIOR ART

FIG. 40
PRIOR ART

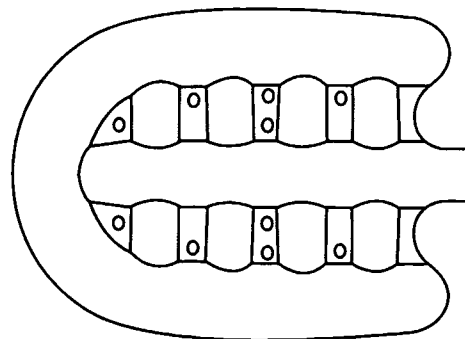

FIG. 41
PRIOR ART

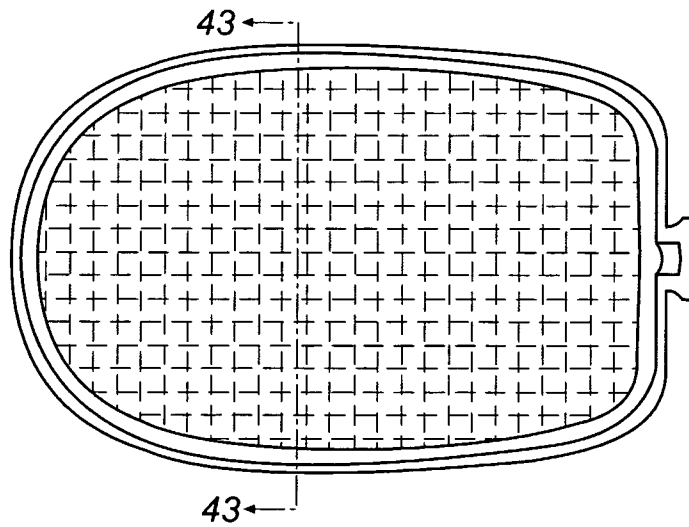
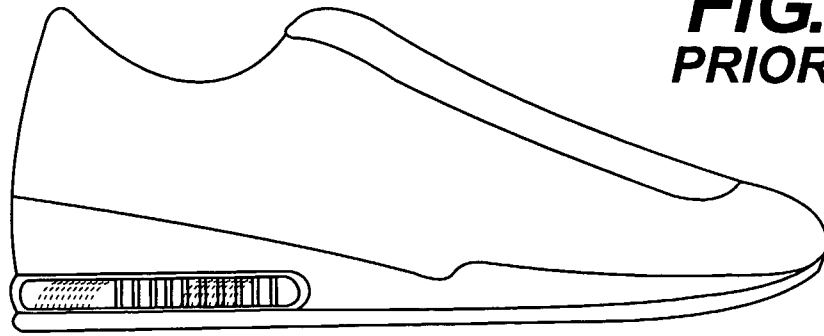
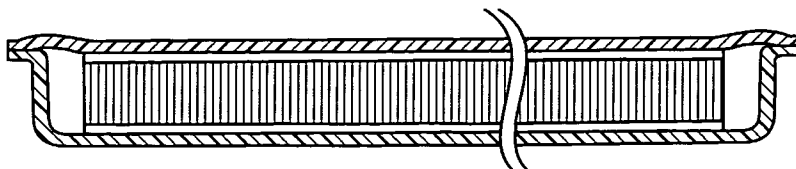

FIG. 42
PRIOR ART

FIG. 43
PRIOR ART



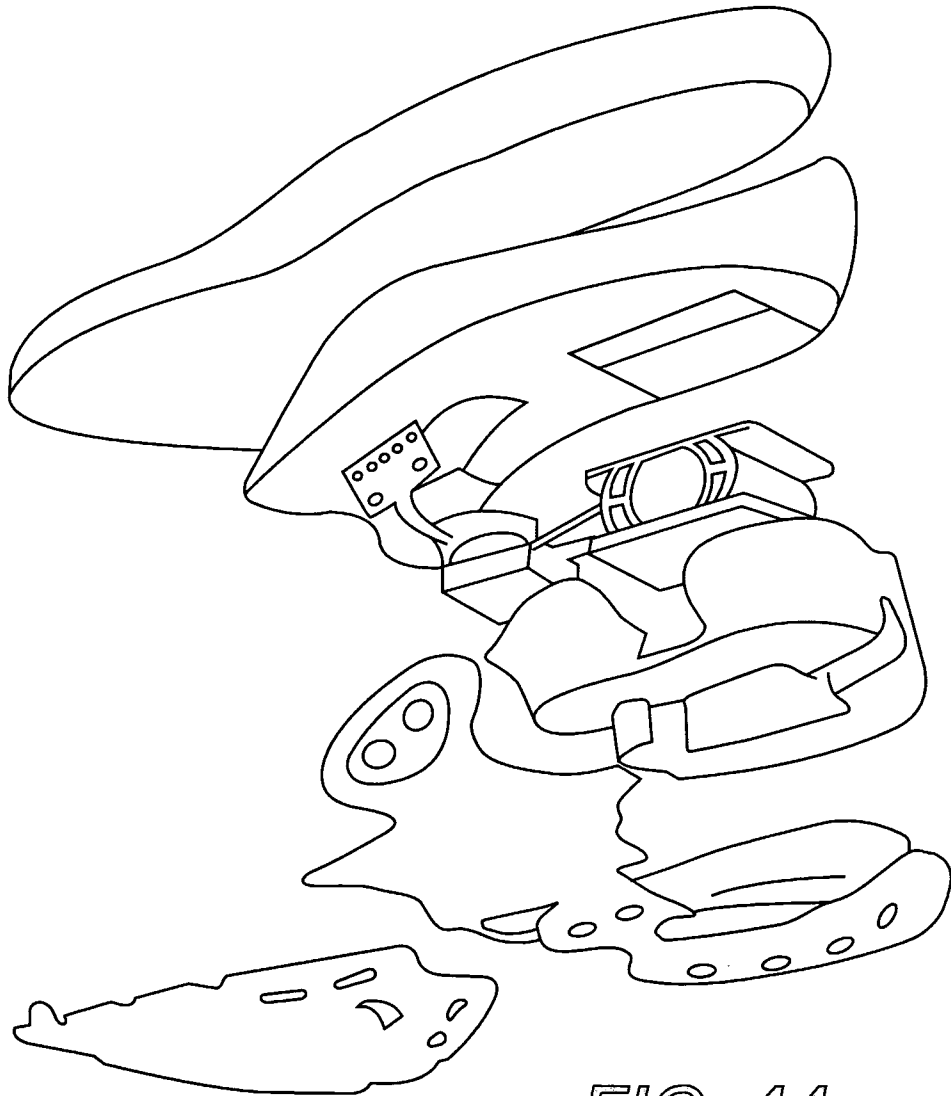

FIG. 44
PRIOR ART

30/59

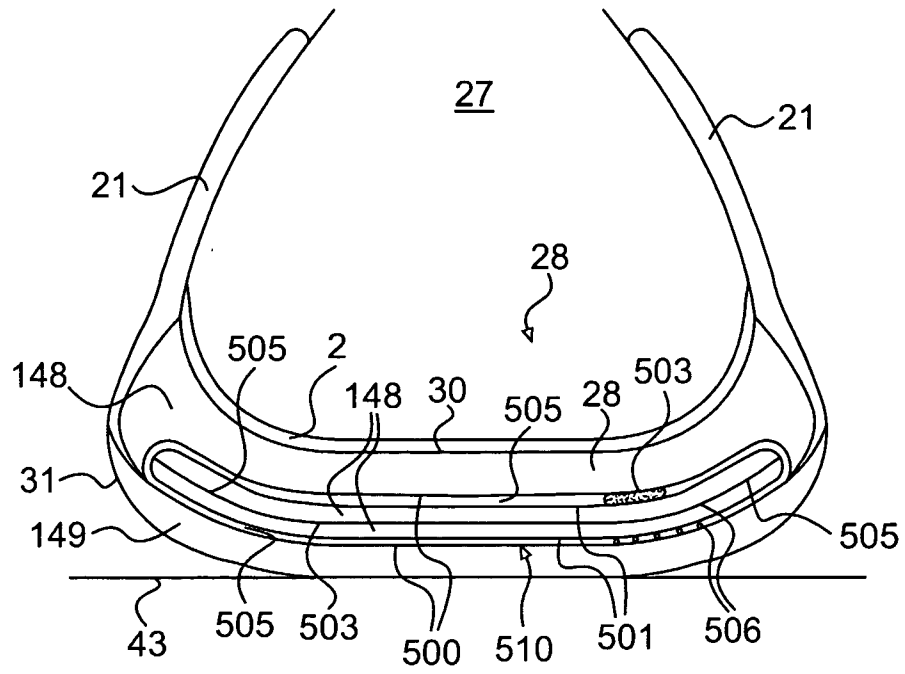

FIG. 45

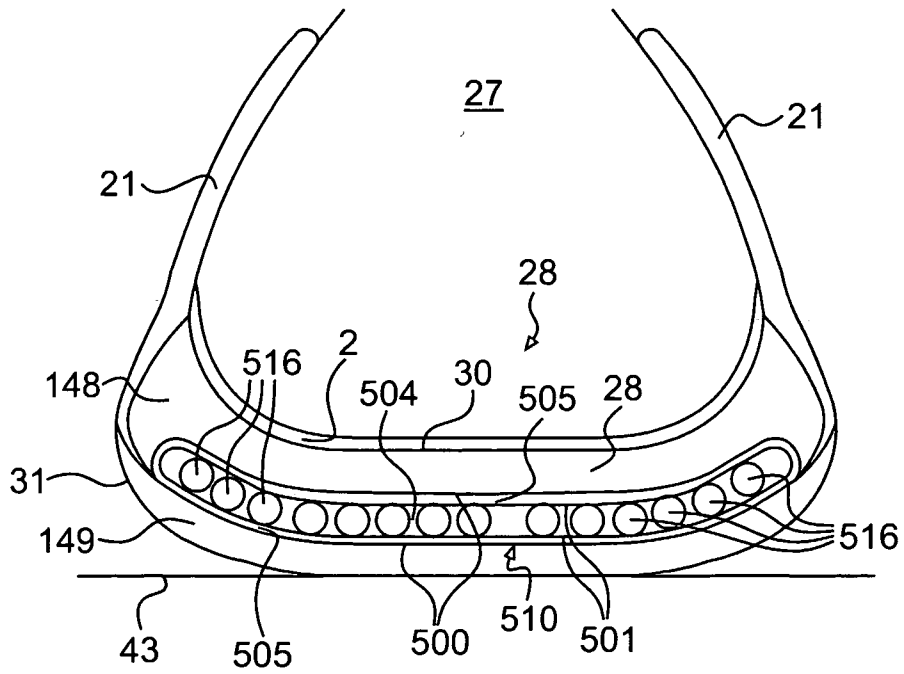

FIG. 46

31/59

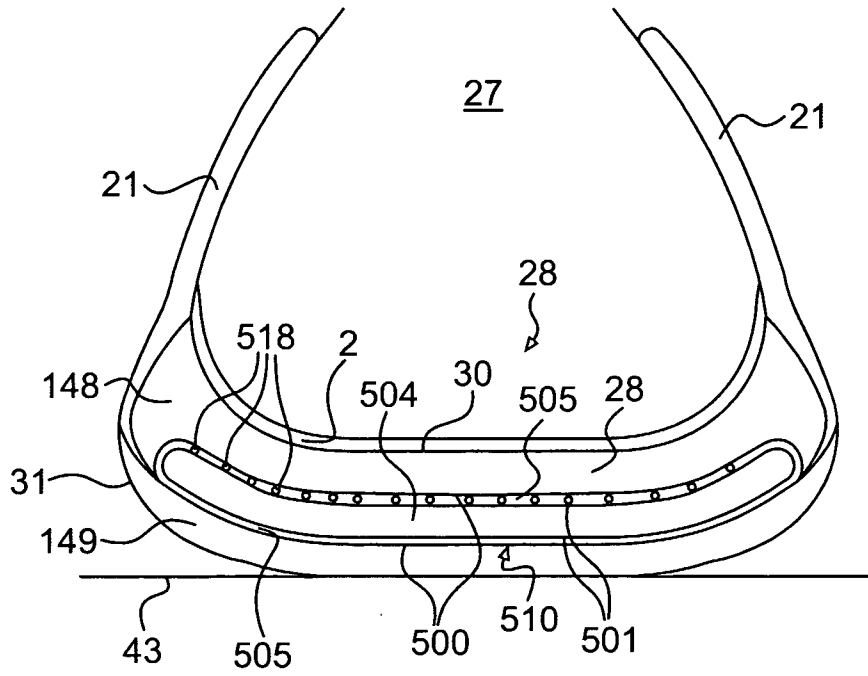

FIG. 47

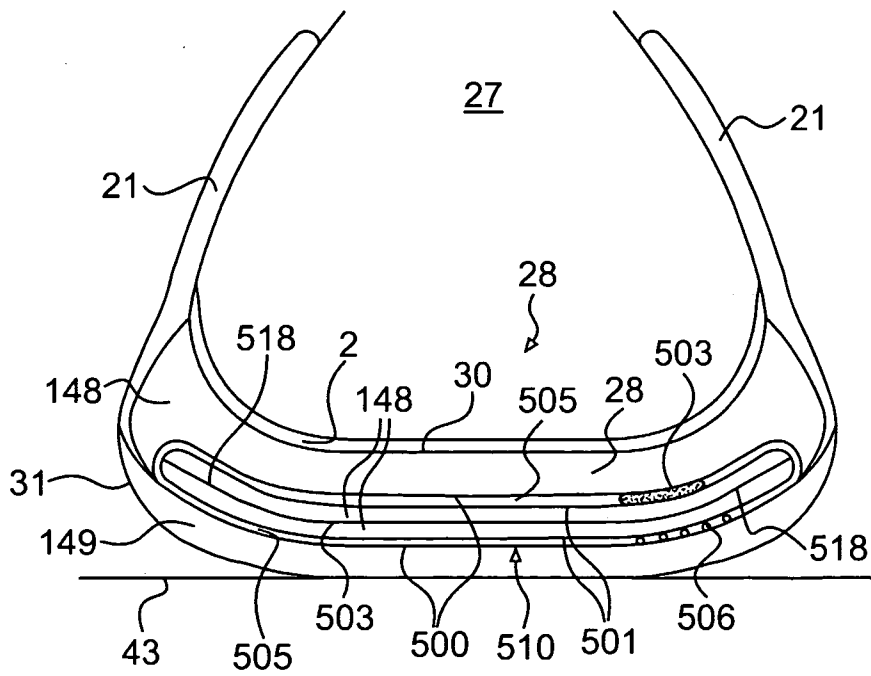

FIG. 48A

32/59

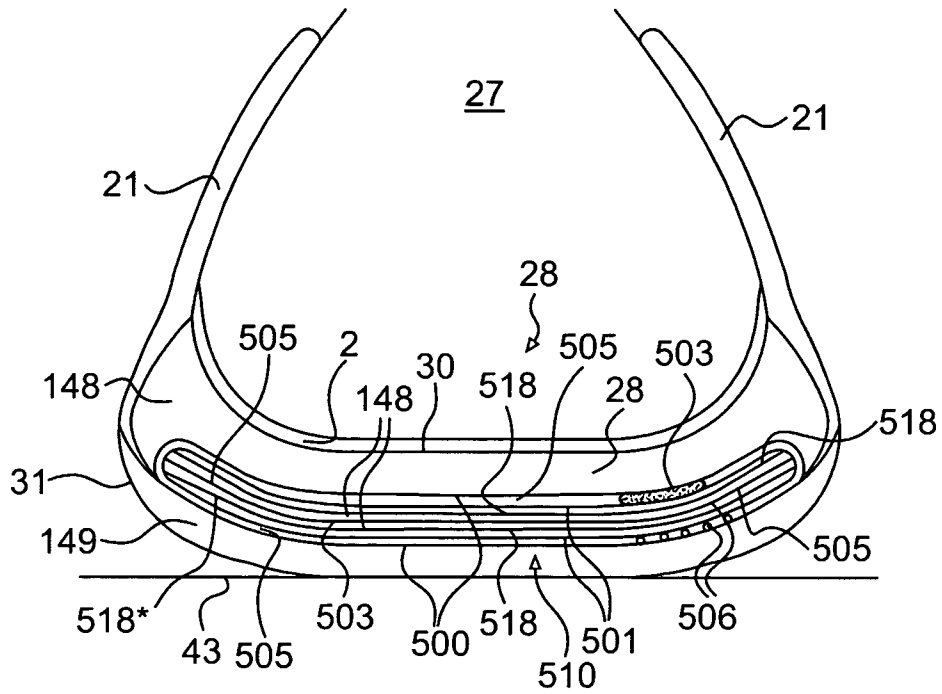

FIG. 48B

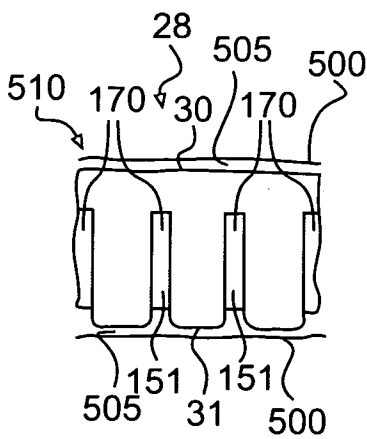

FIG. 48C

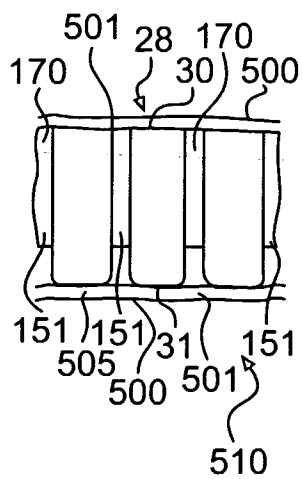

FIG. 48D

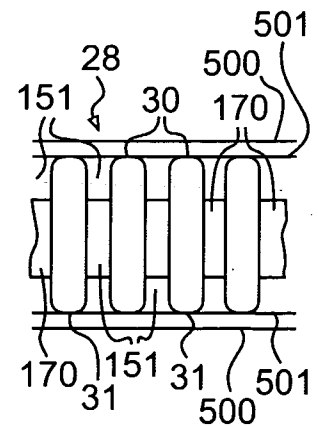

FIG. 48E

FIG. 49

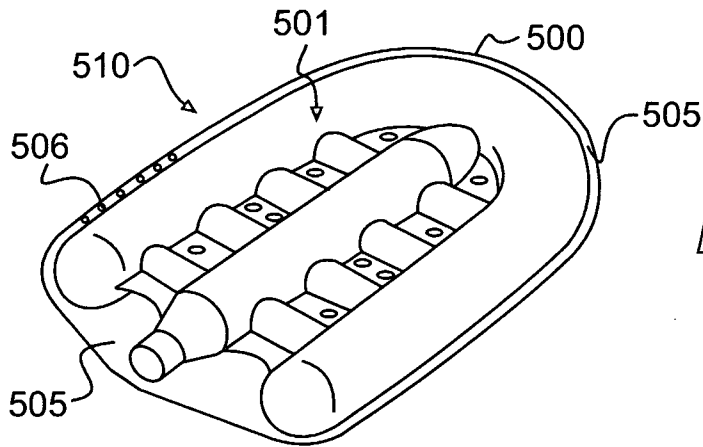
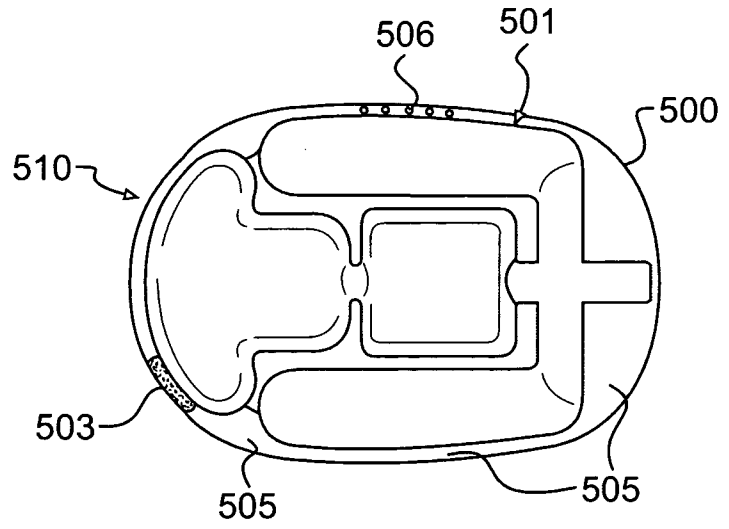
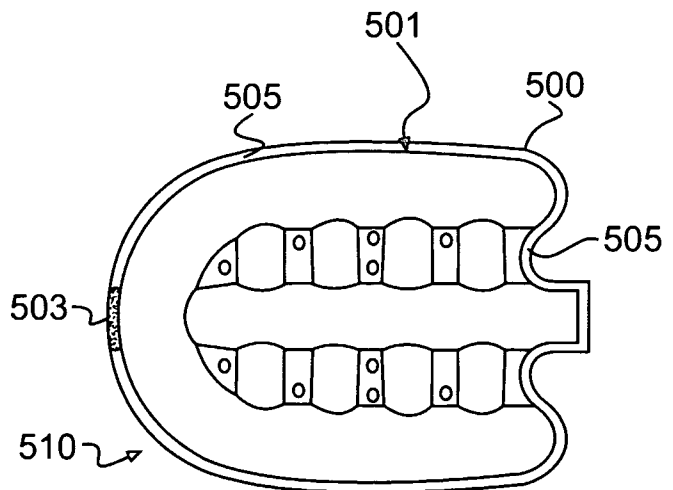

FIG. 50

FIG. 51



34/59

FIG. 52

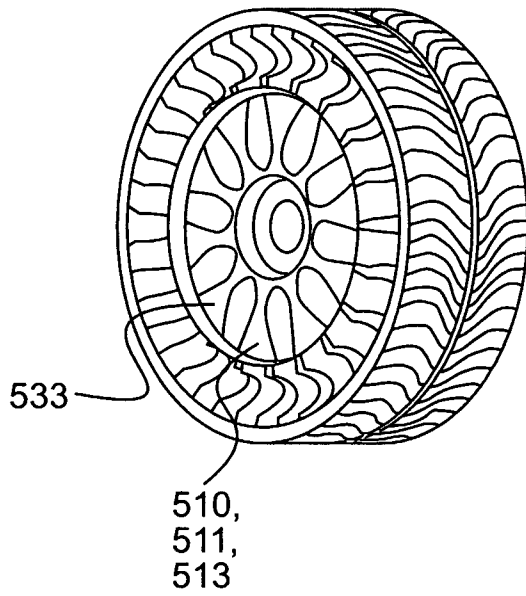
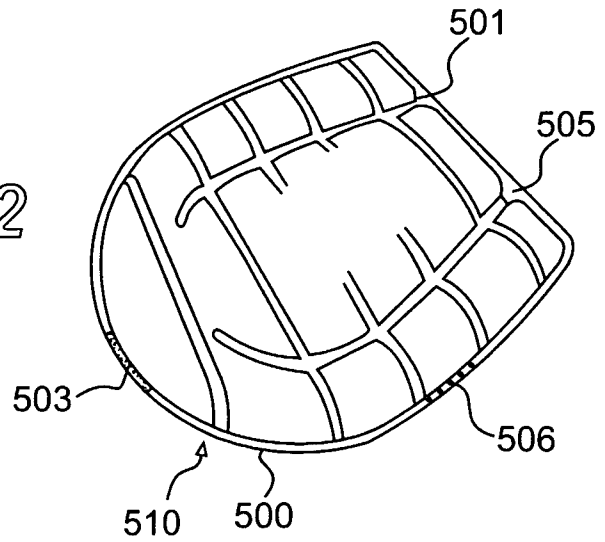
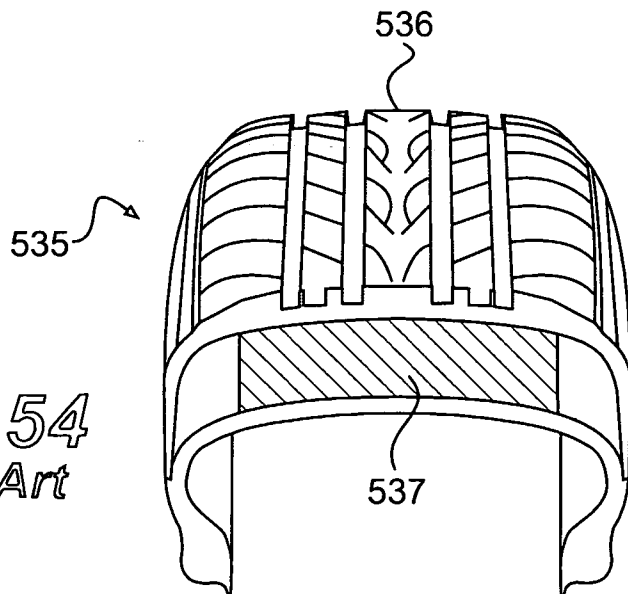

FIG. 53

FIG. 54
Prior Art



35/59

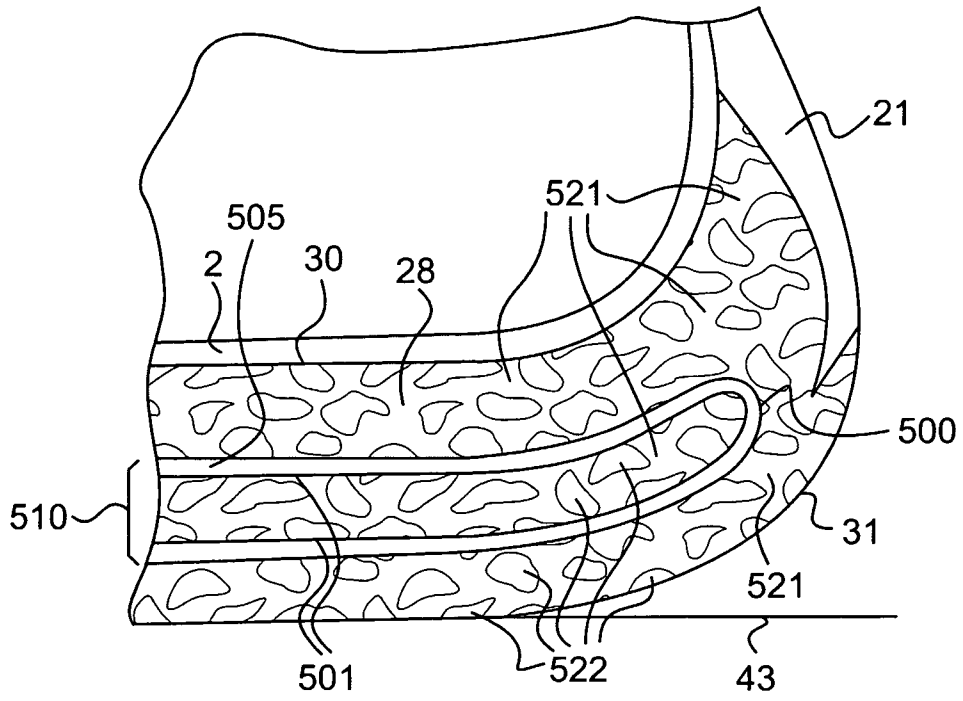

FIG. 55

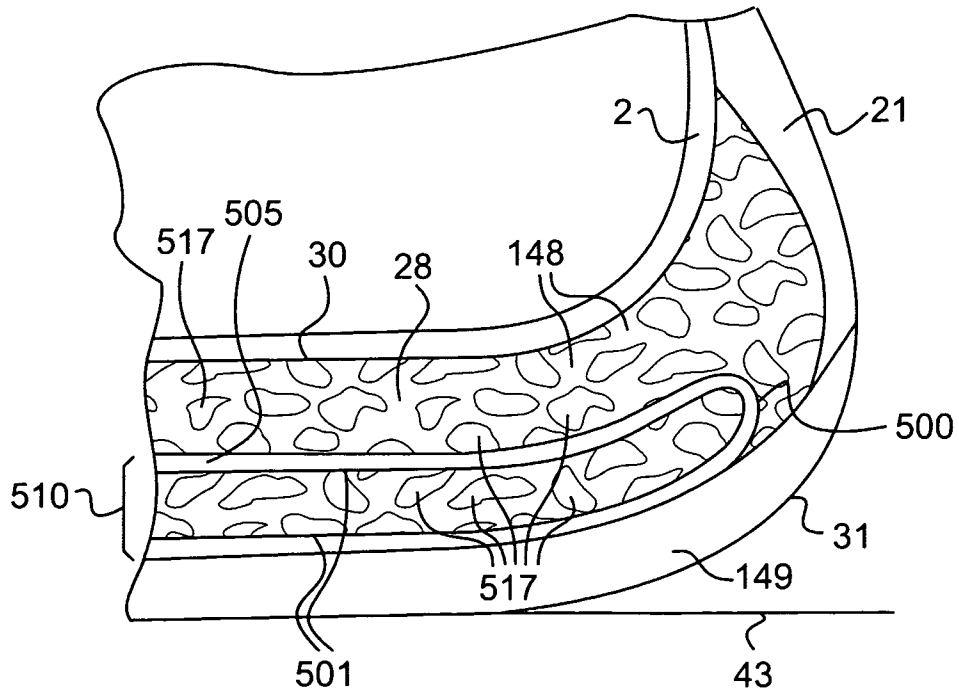

FIG. 56

36/59

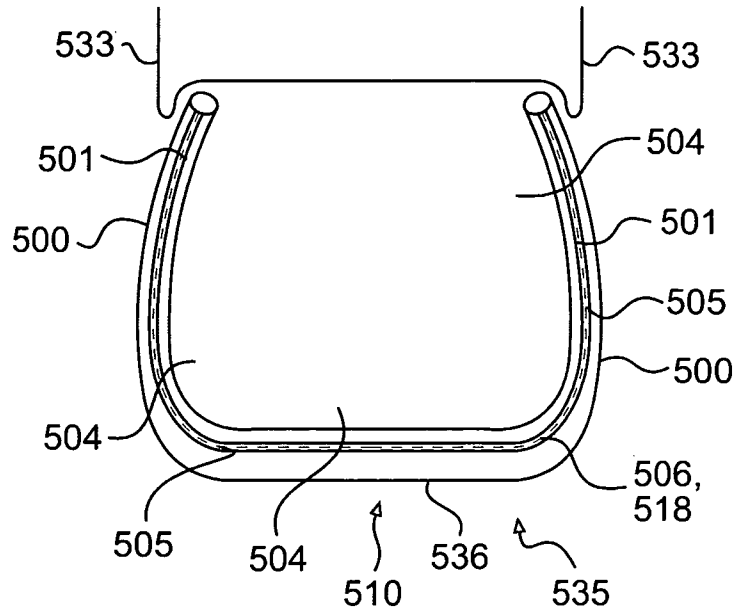

FIG. 57

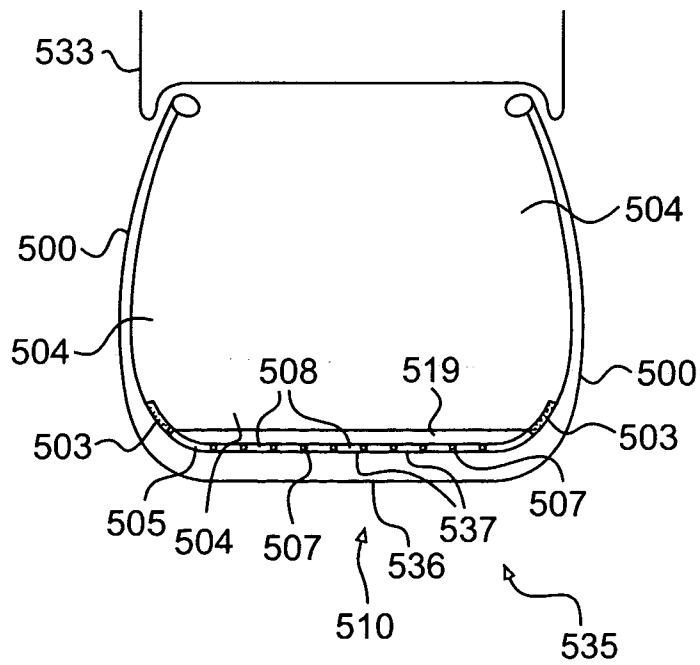

FIG. 58

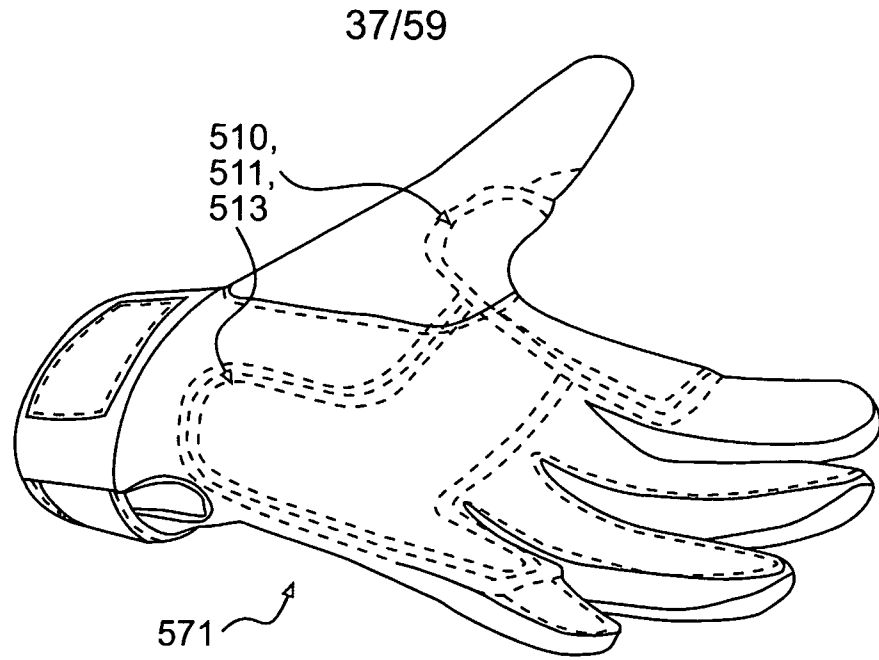

FIG. 59

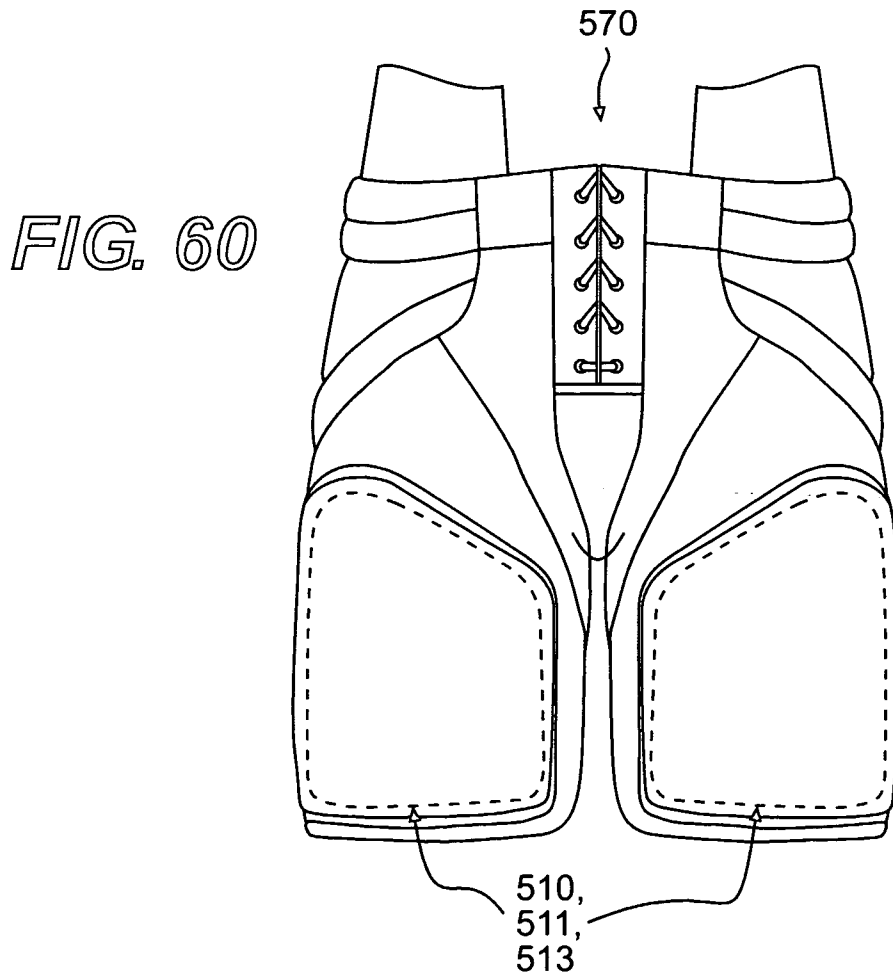

FIG. 60

38/59

FIG. 61A

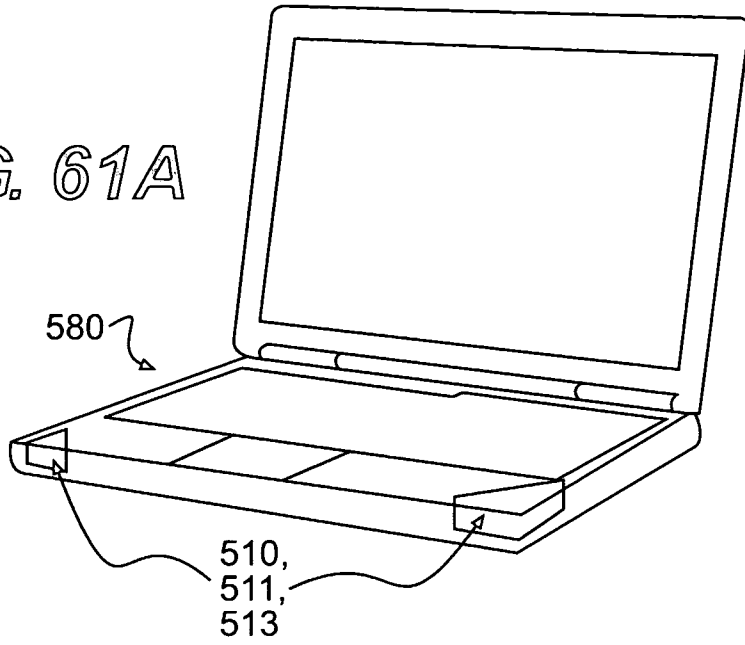

FIG. 61B

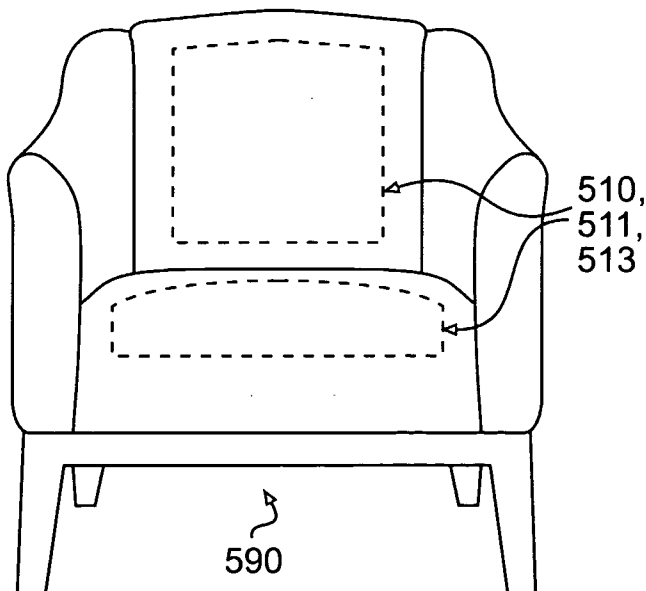
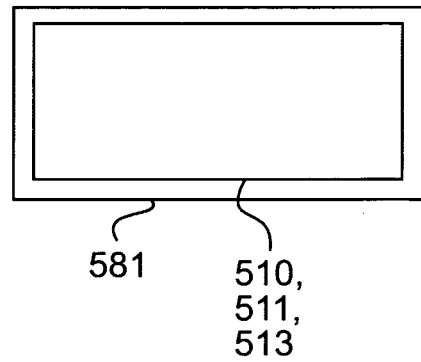
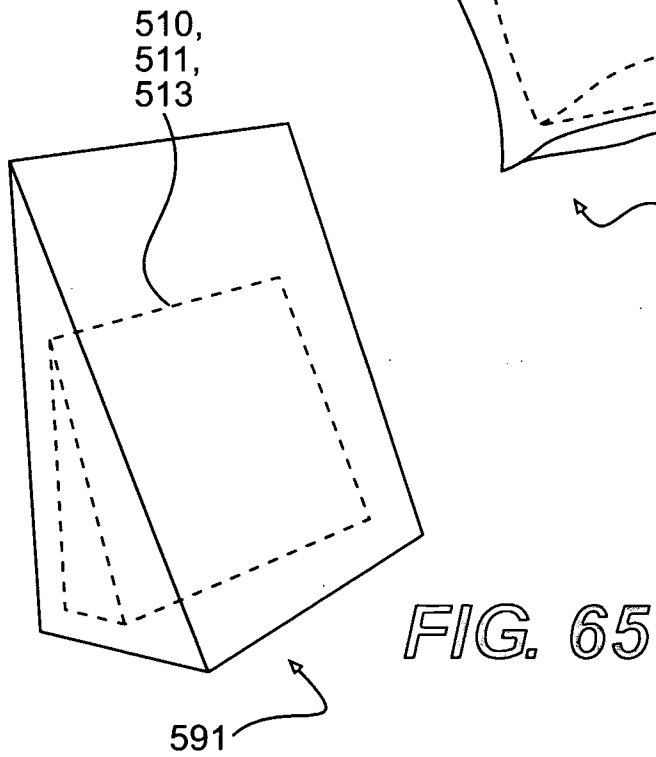
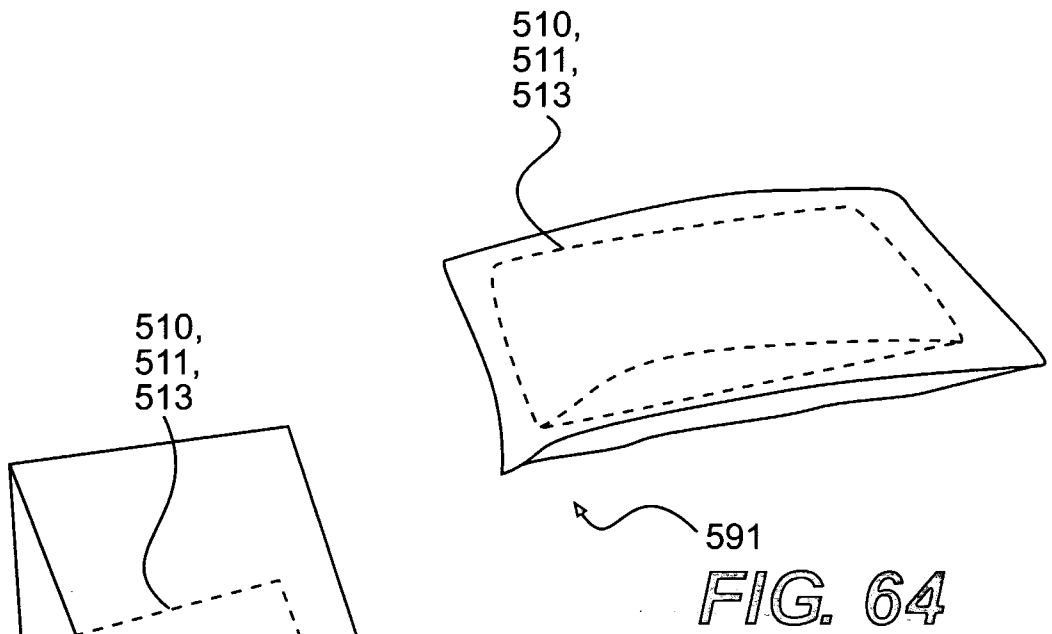
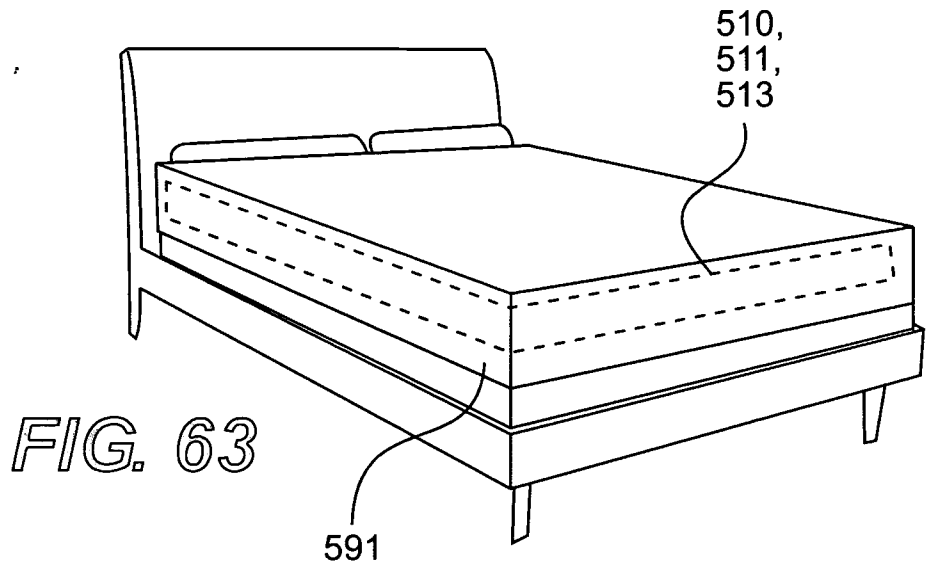

FIG. 62

39/59



40/59

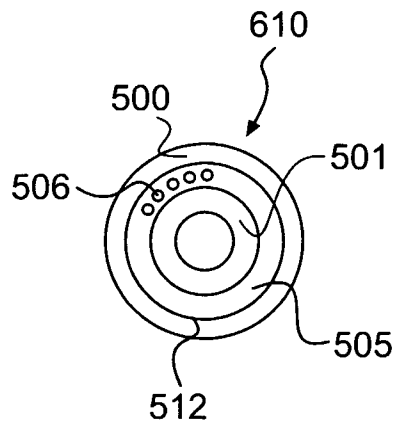

FIG. 66

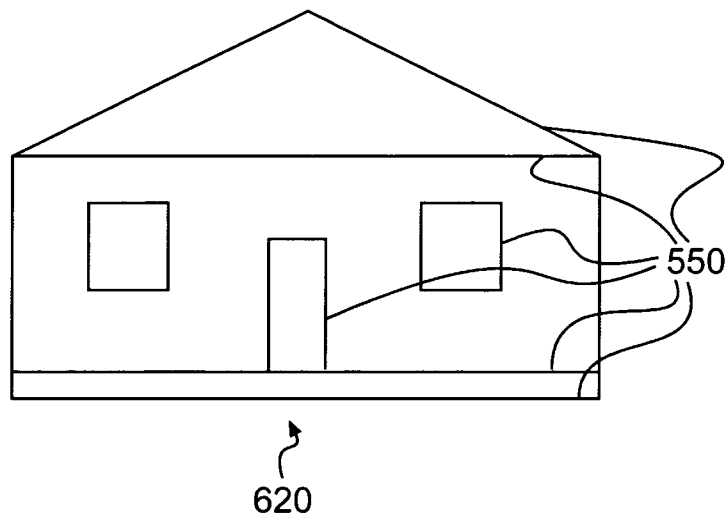

FIG. 68

APPROXIMATE COMPARISON OF HARDNESS SCALES

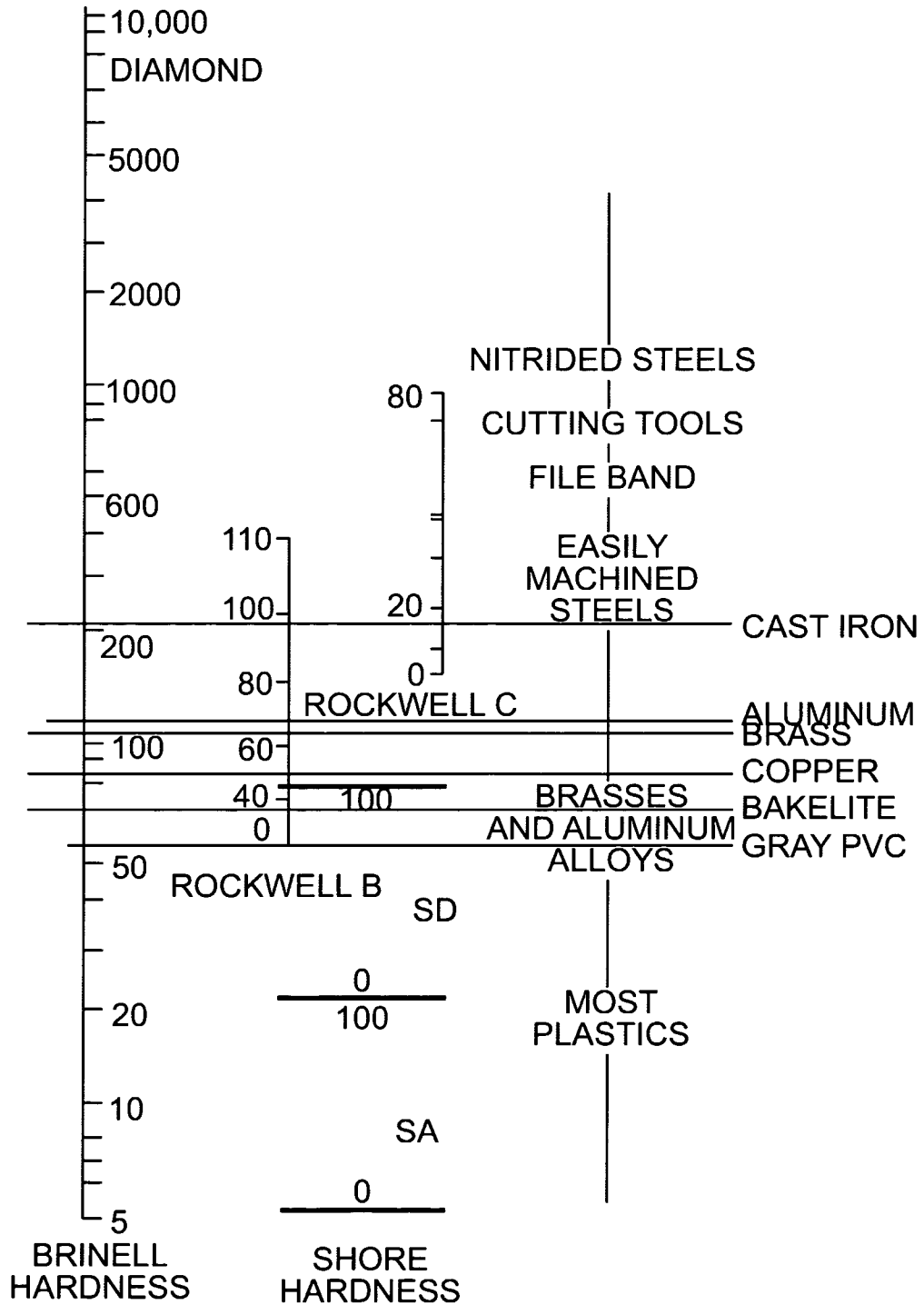

FIG. 67

42/59

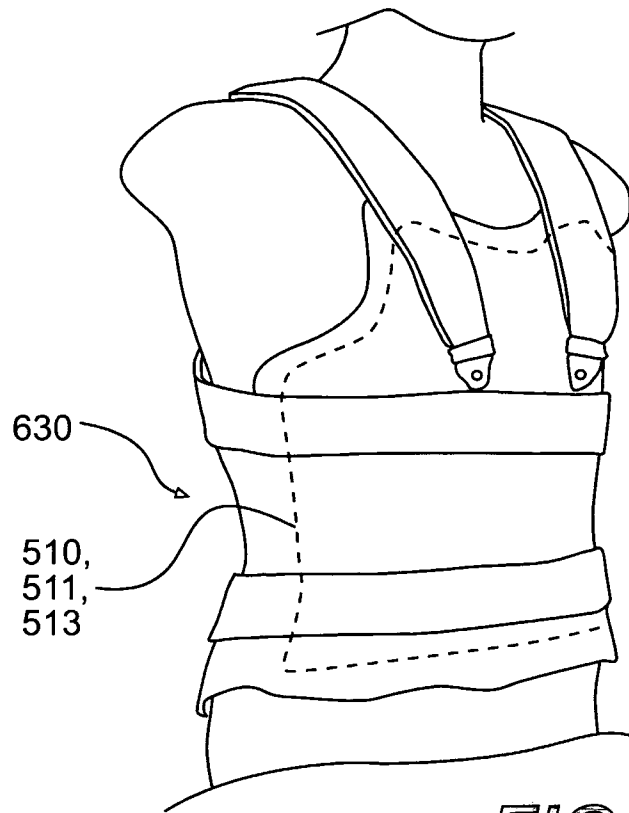

FIG. 69

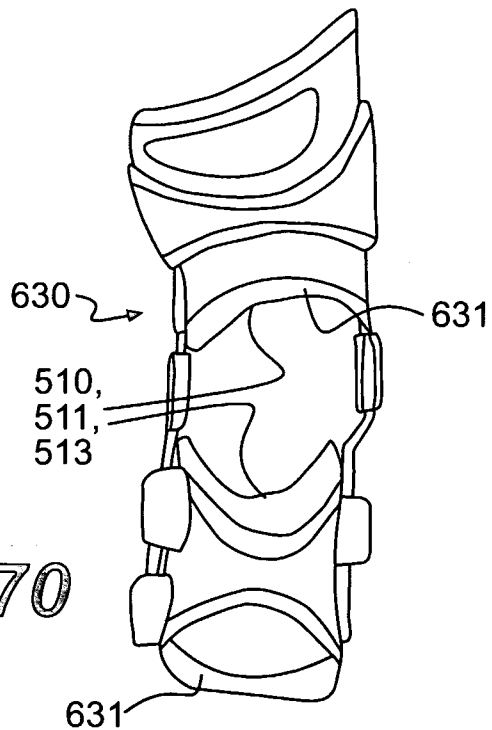

FIG. 70

43/59

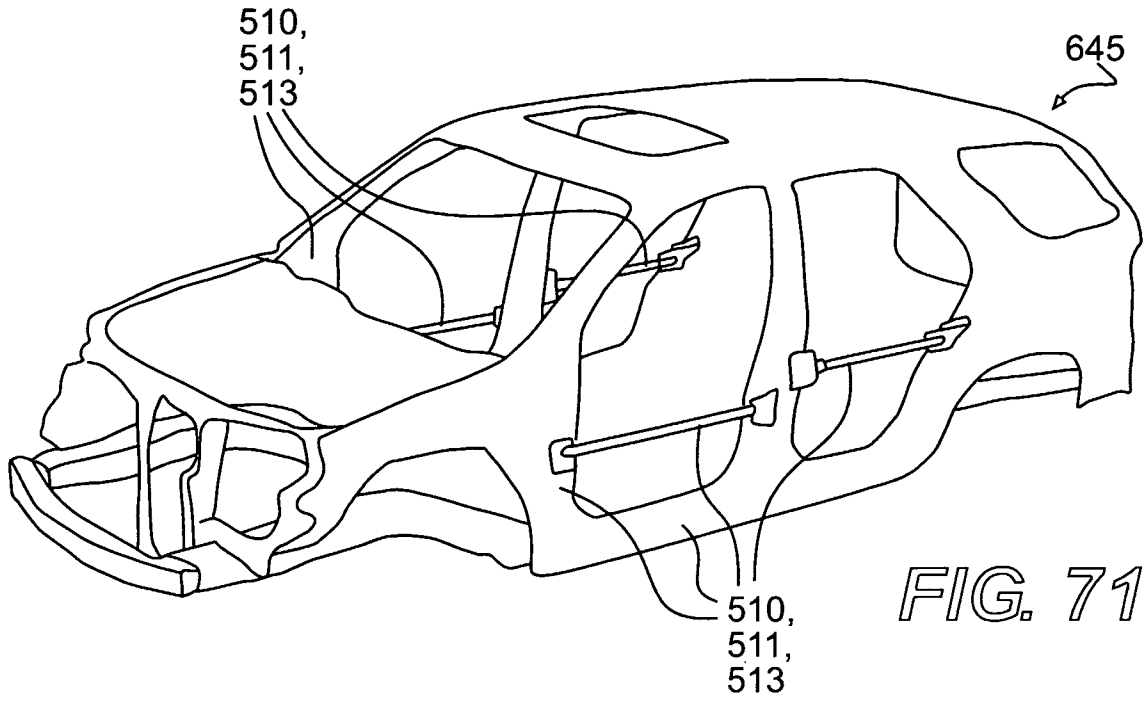

FIG. 71

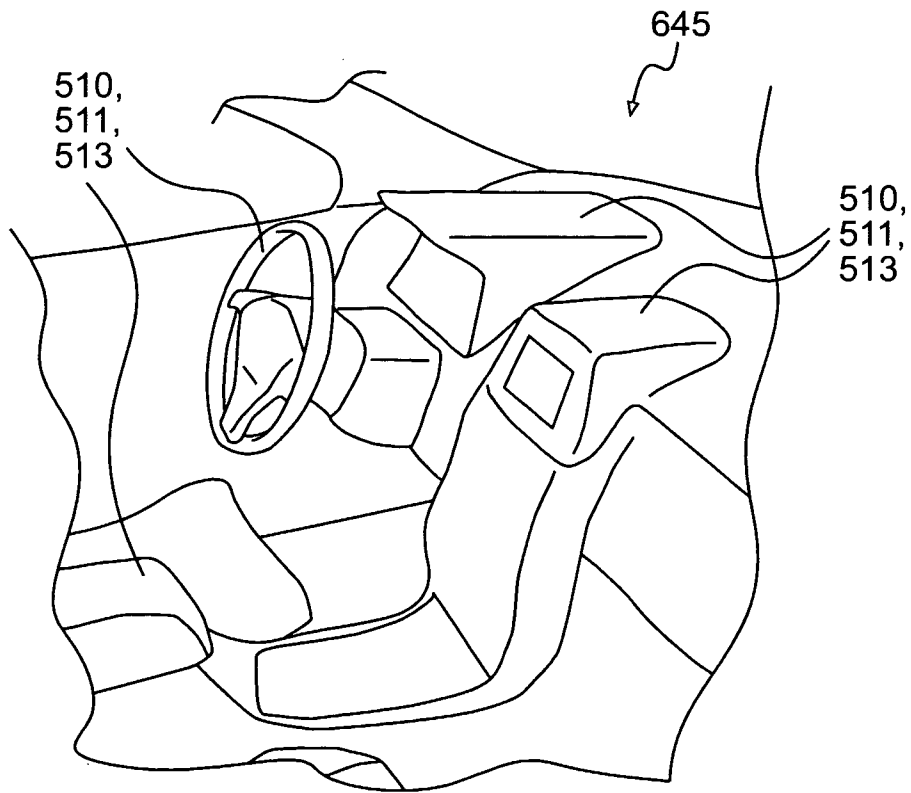

FIG. 72

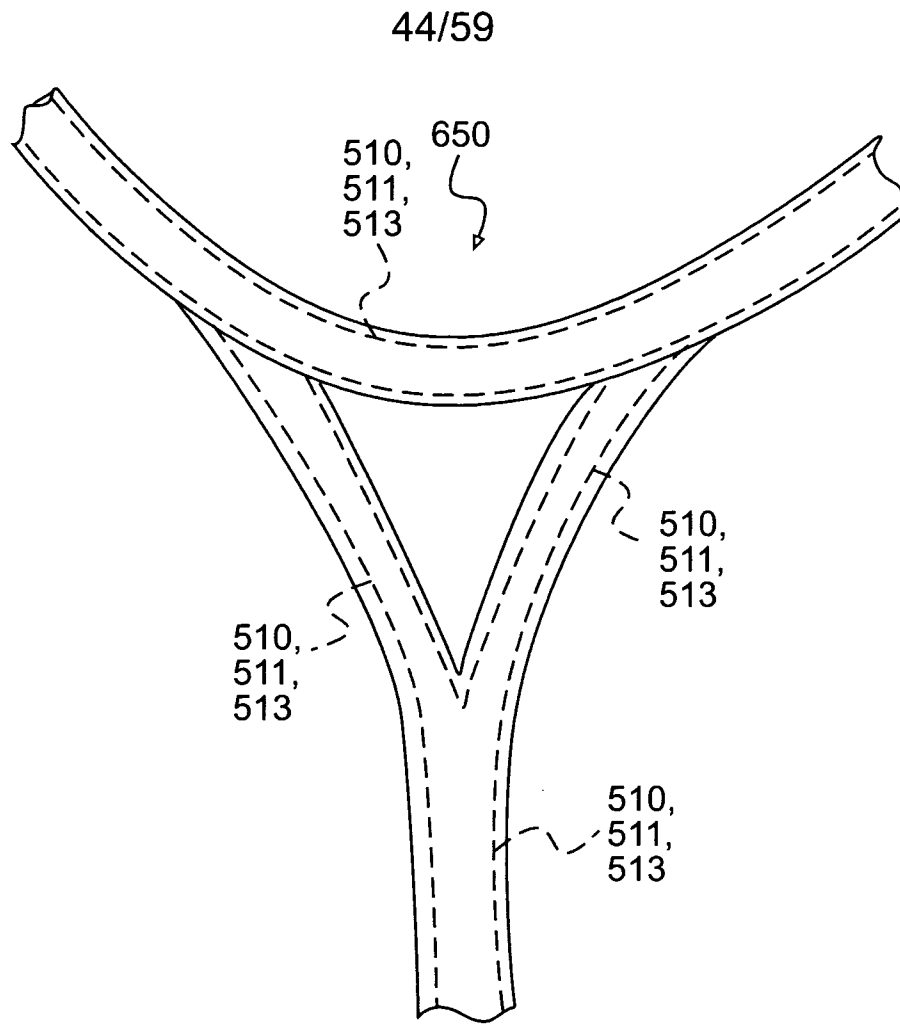

FIG. 73A

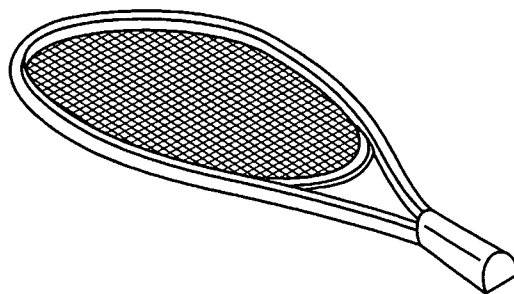

FIG. 73B
PRIOR ART

45/59

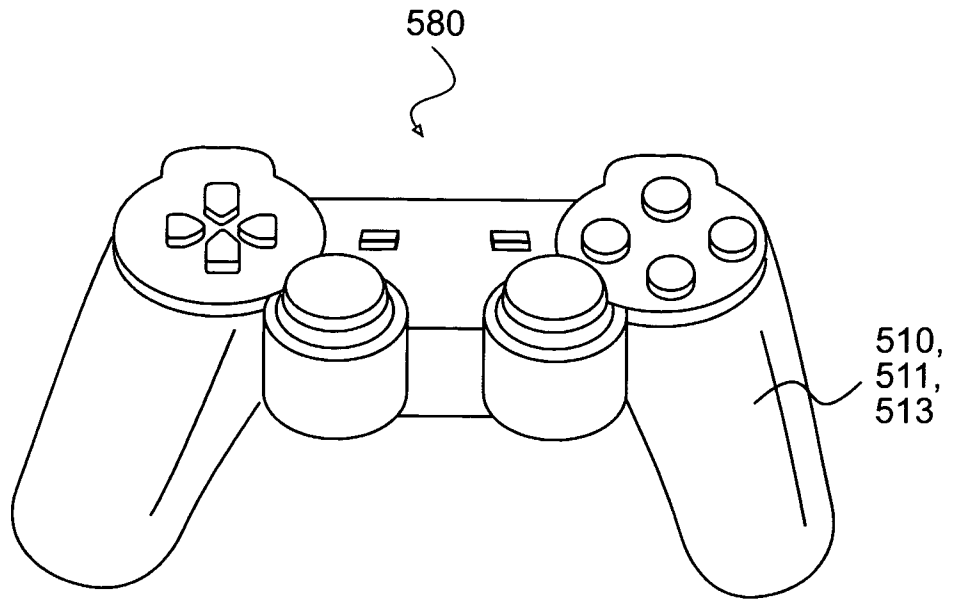

FIG. 74

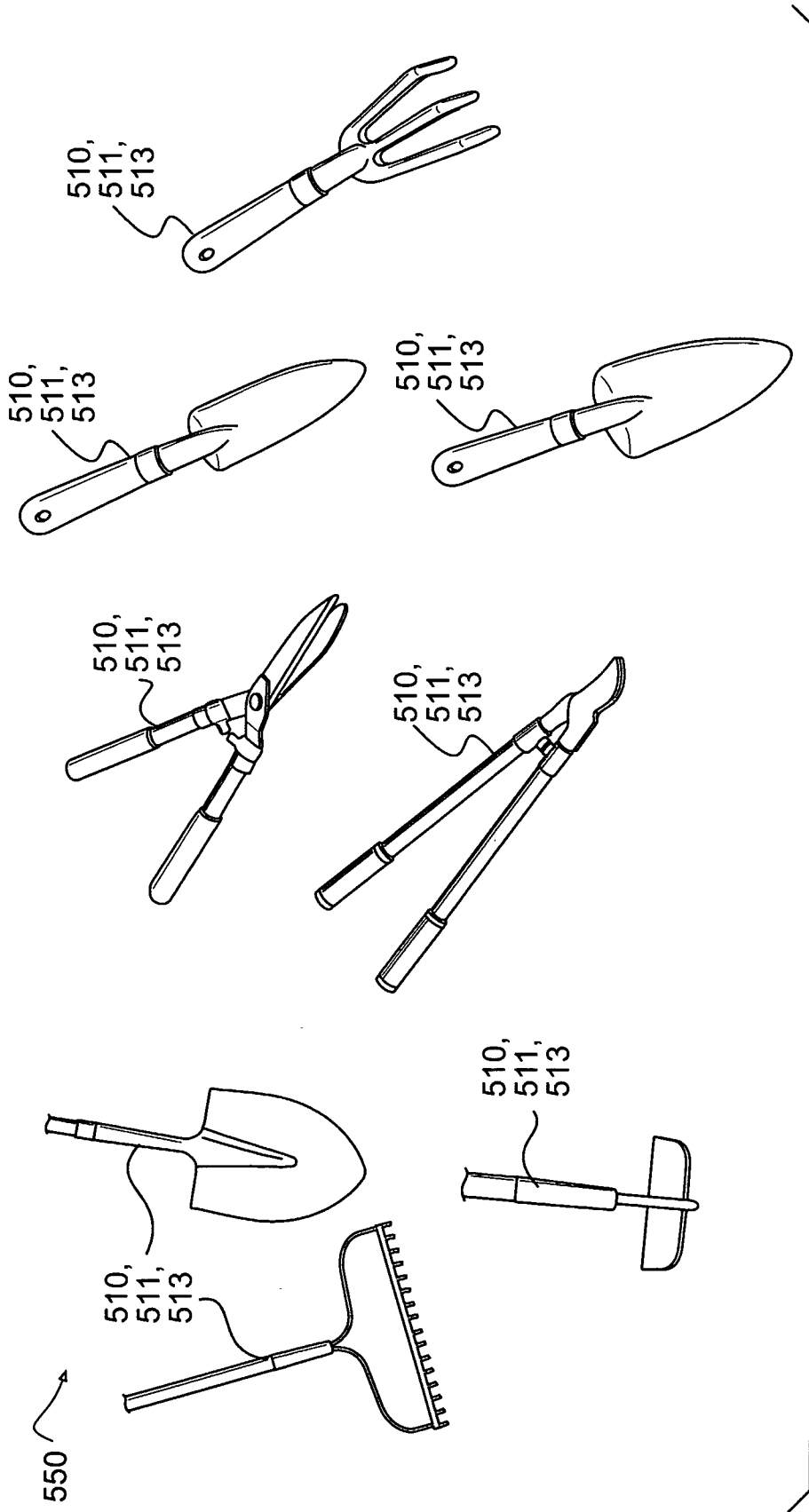

FIG. 75

47/59

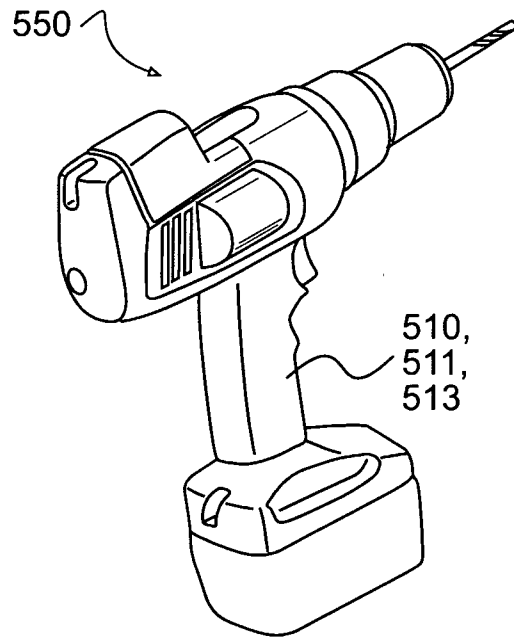

FIG. 76

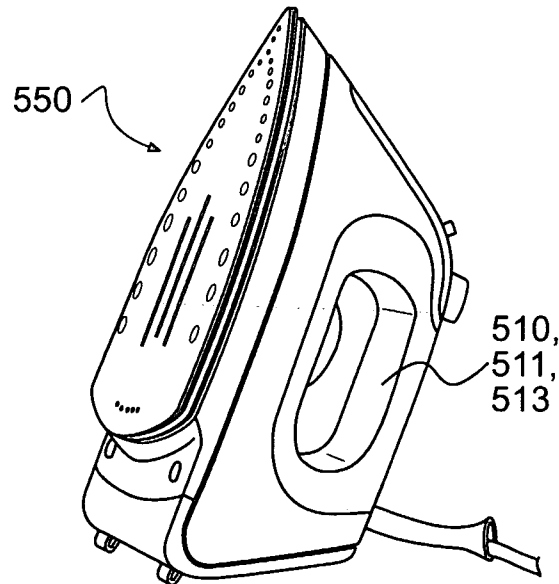

FIG. 77

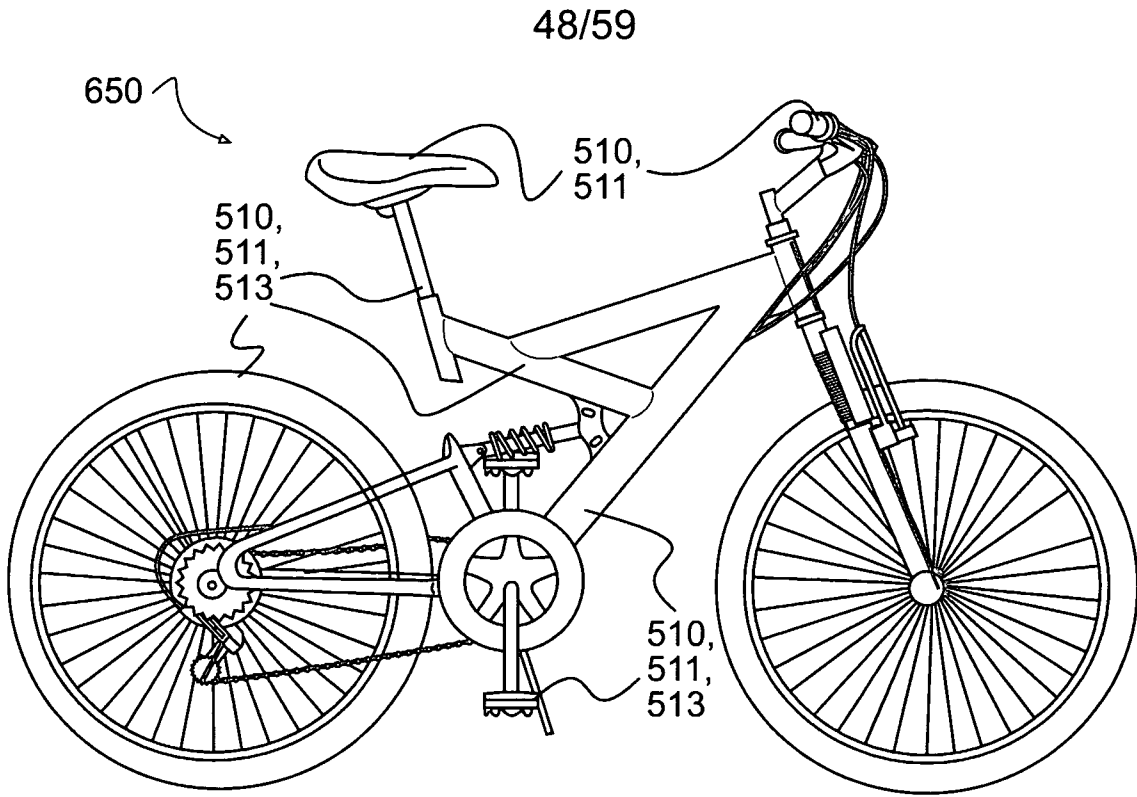

FIG. 78

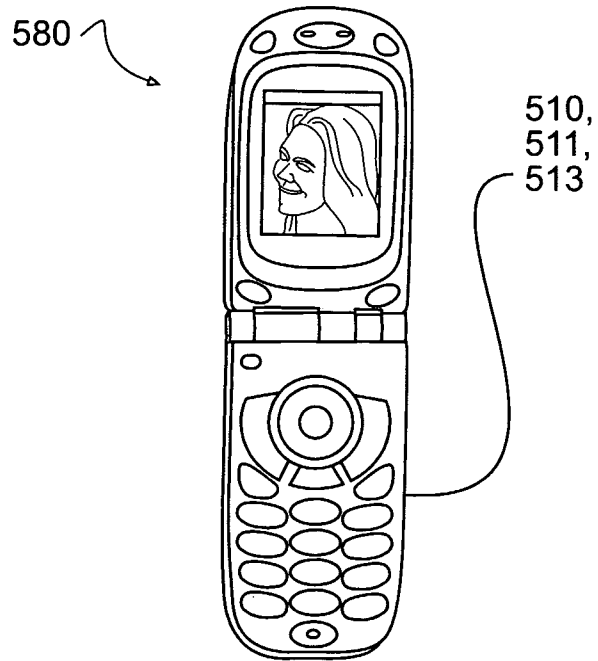

FIG. 79

49/59

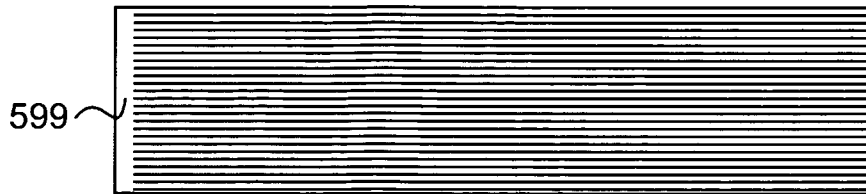

FIG. 80A

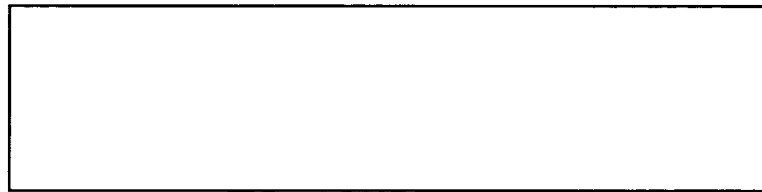

FIG. 80B

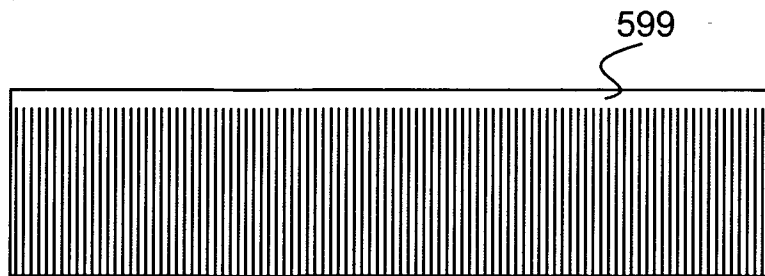

FIG. 80C

51/59

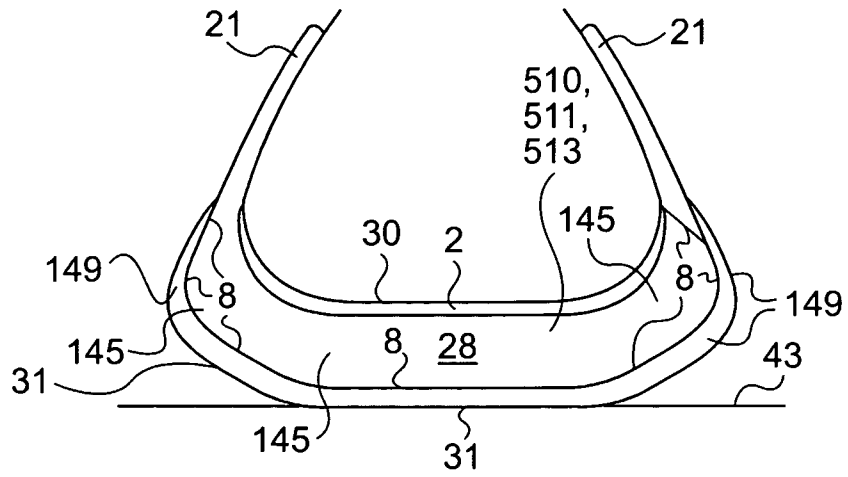

FIG. 82A

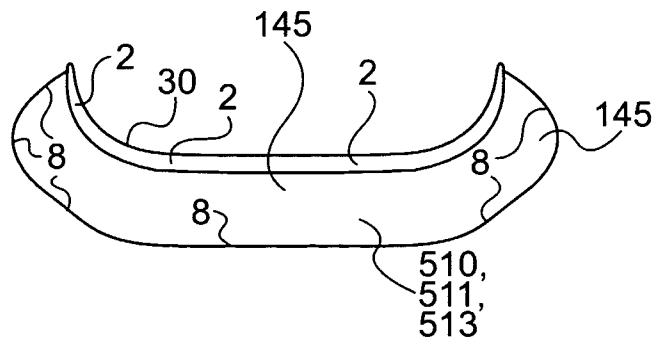

FIG. 82B

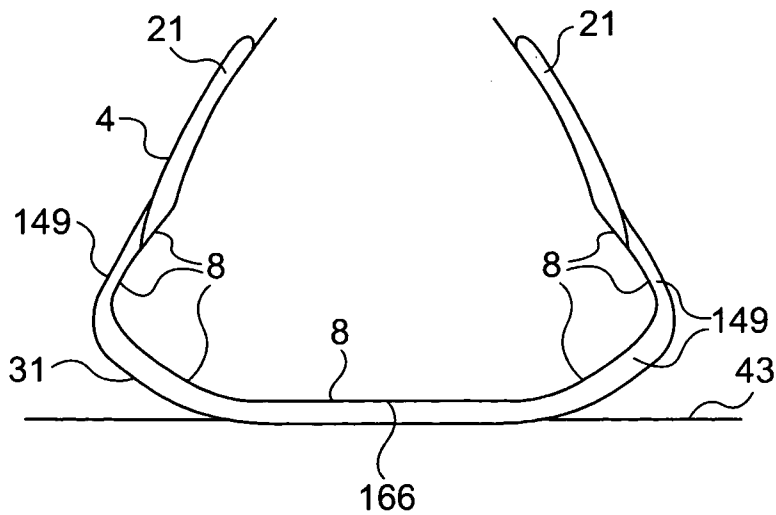

FIG. 82C

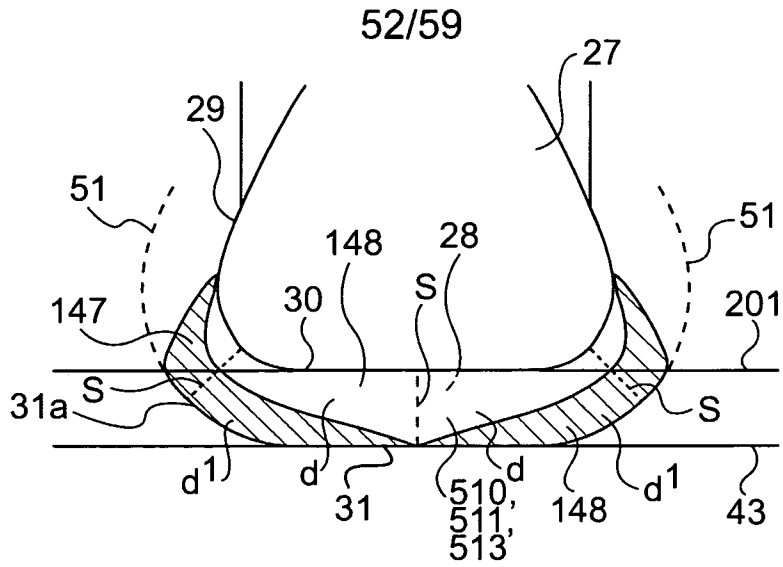

FIG. 83A

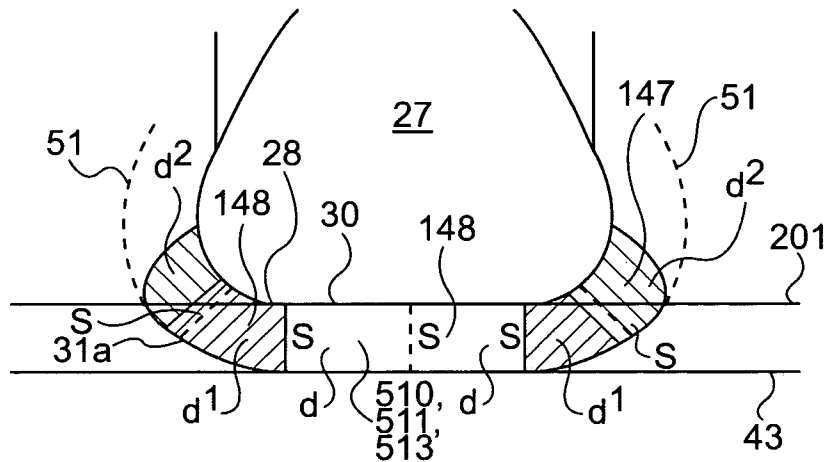

FIG. 83B

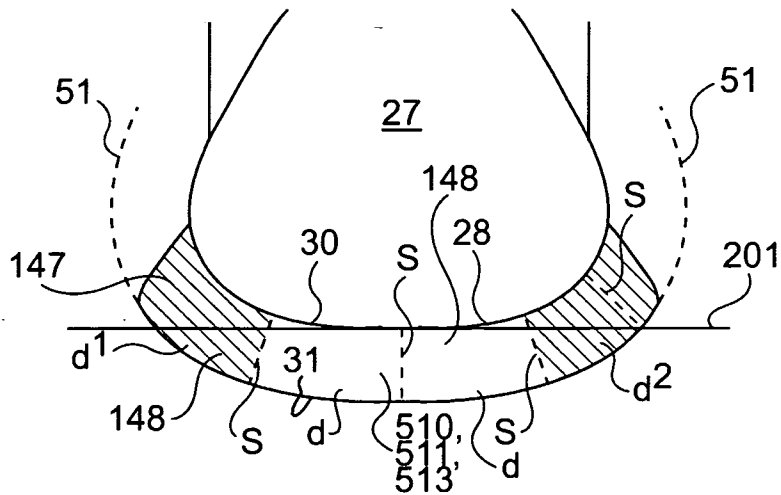

FIG. 83C

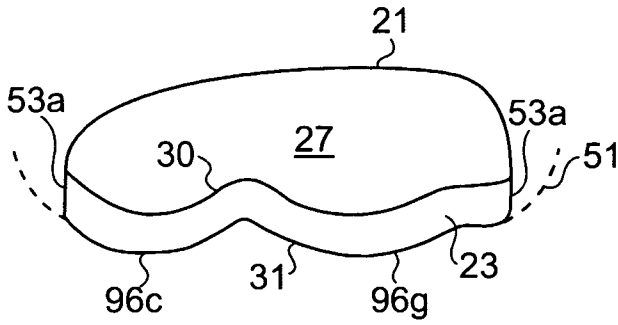

FIG. 84A

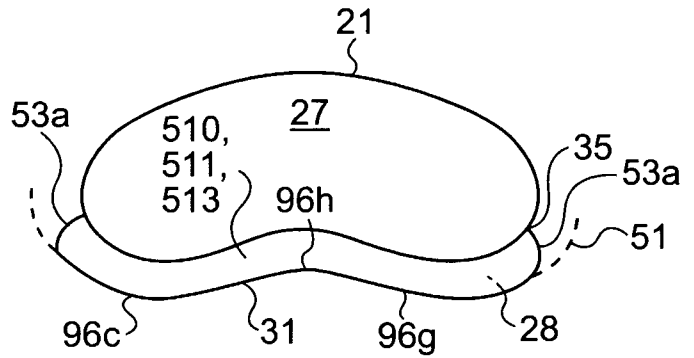

FIG. 84B

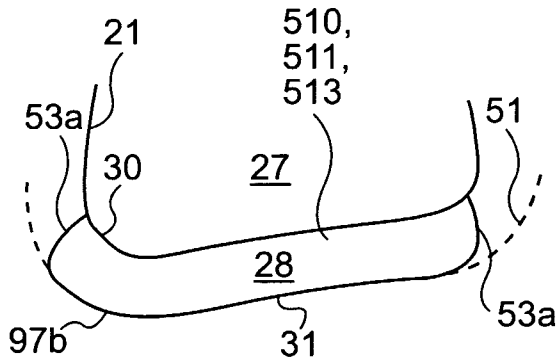

FIG. 84C

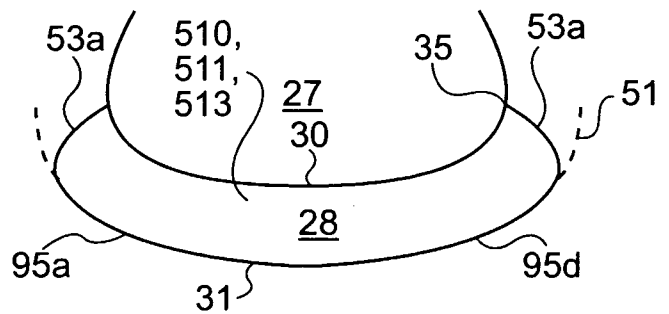

FIG. 84D

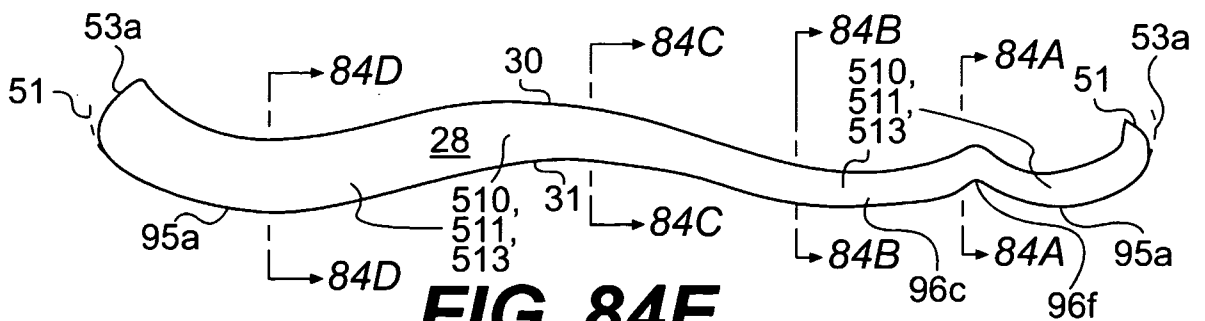

FIG. 84E

54/59

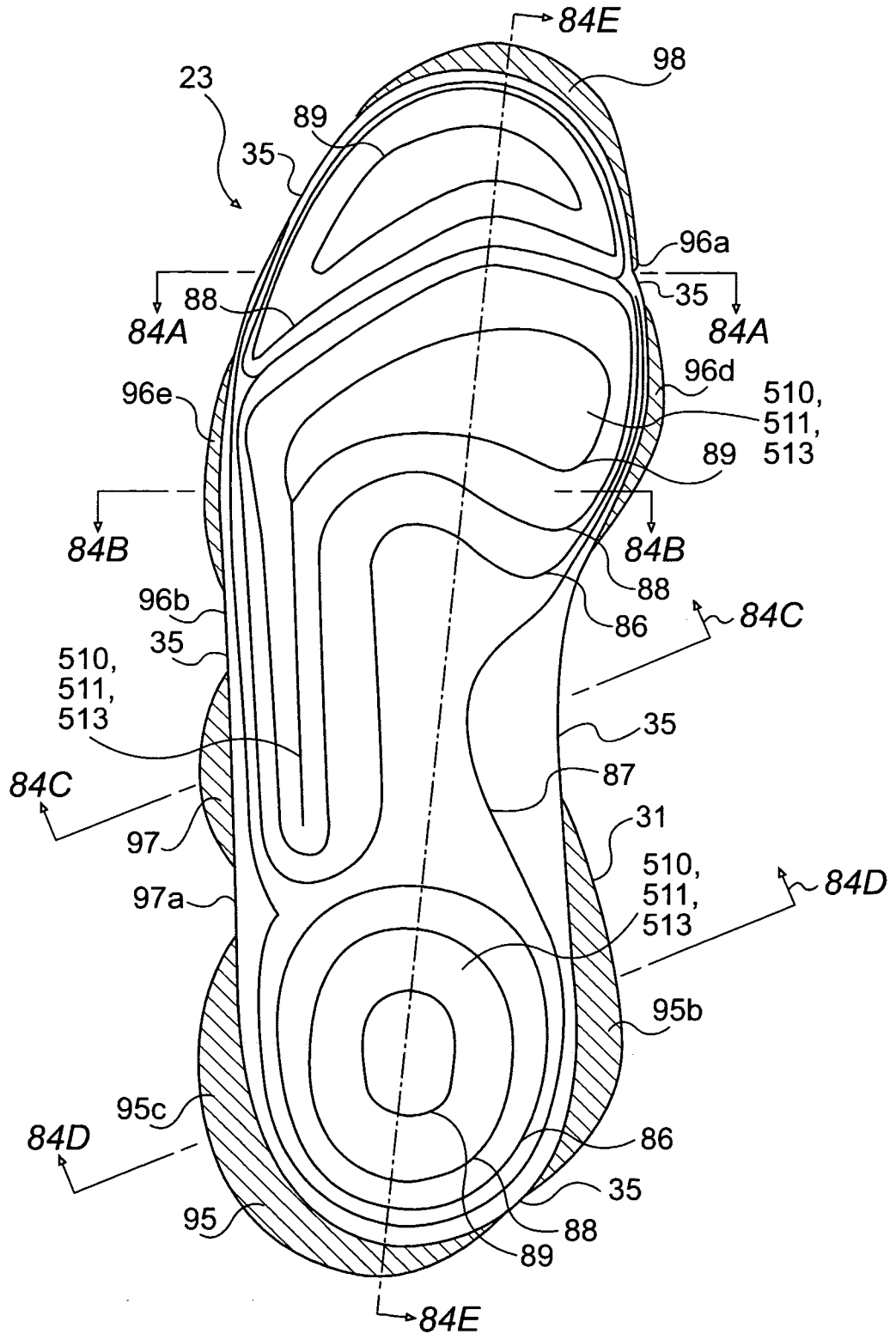

FIG. 84F

55/59

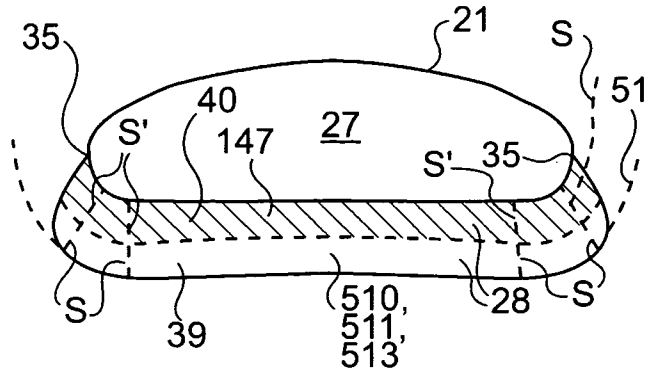

FIG. 85A

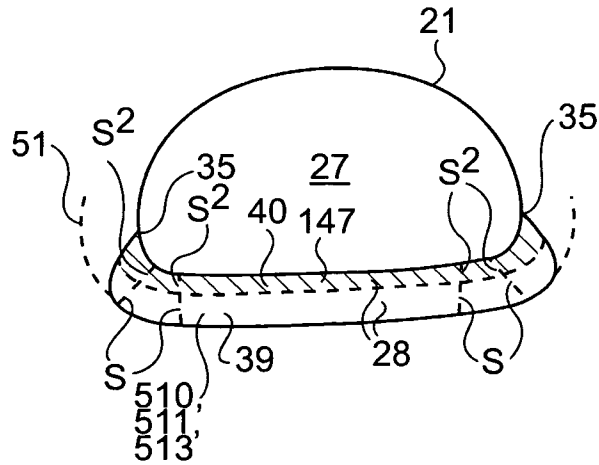

FIG. 85B

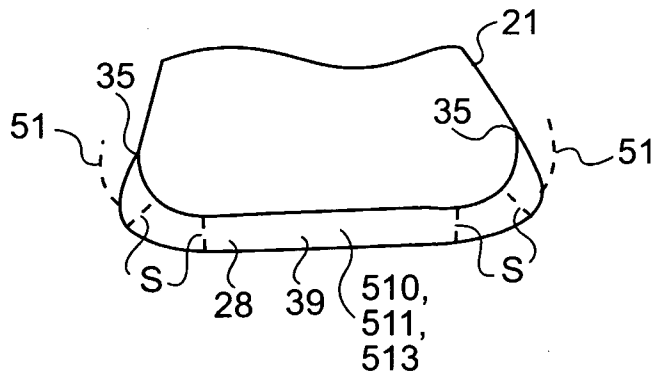

FIG. 85C

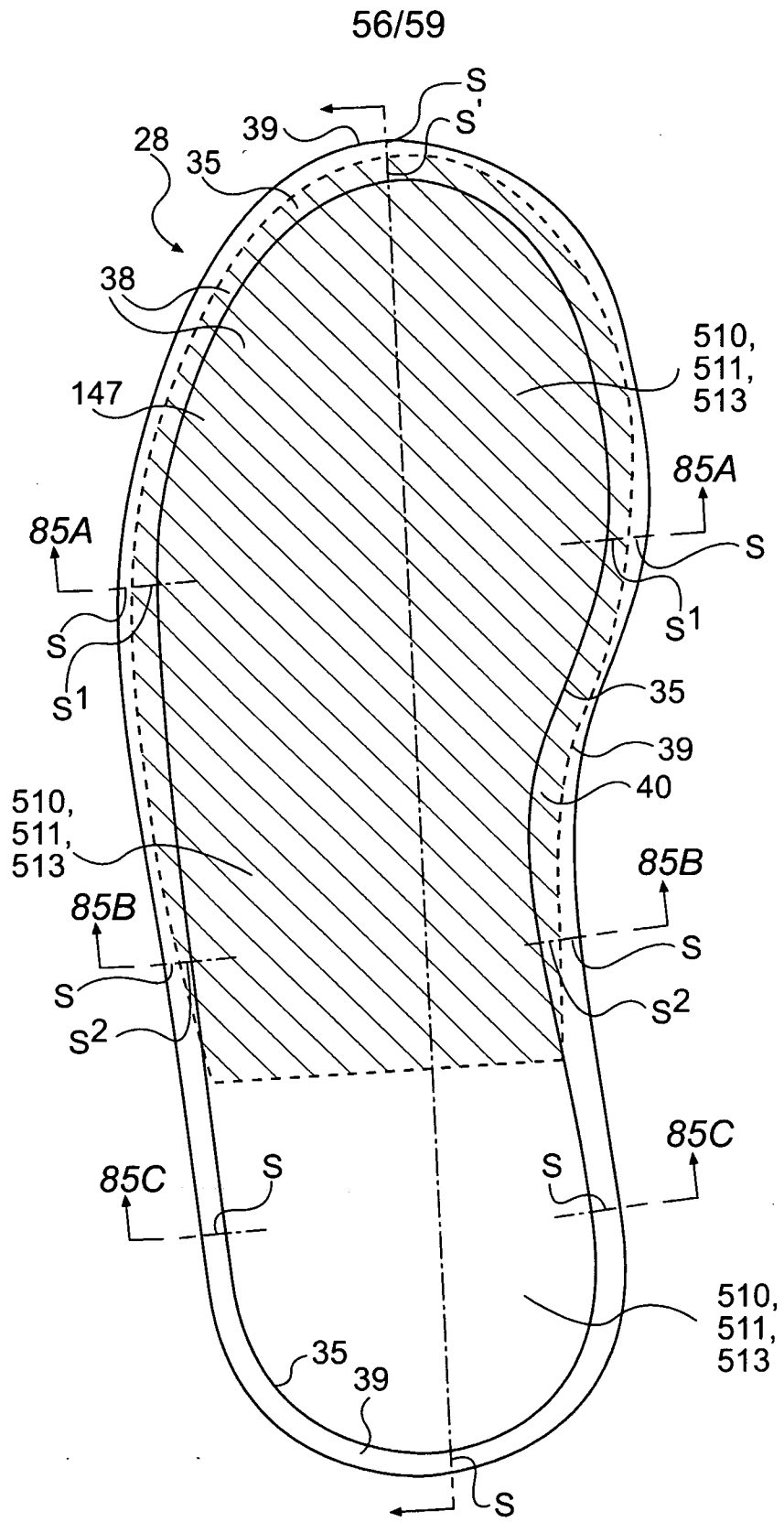

FIG. 85D

57/59

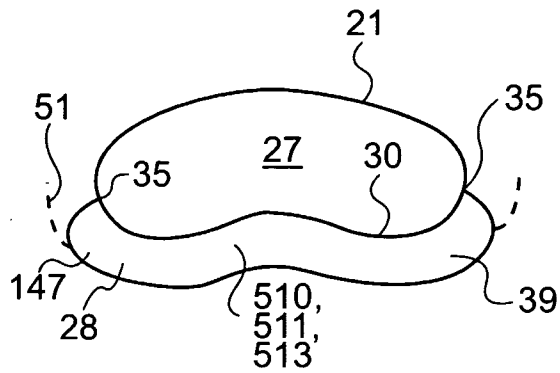

FIG. 86A

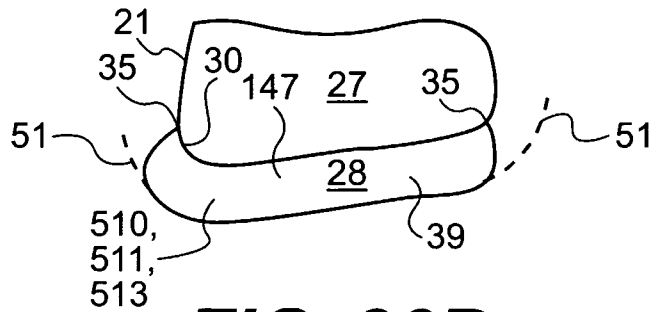

FIG. 86B

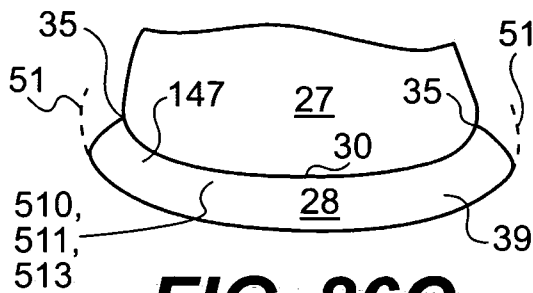

FIG. 86C

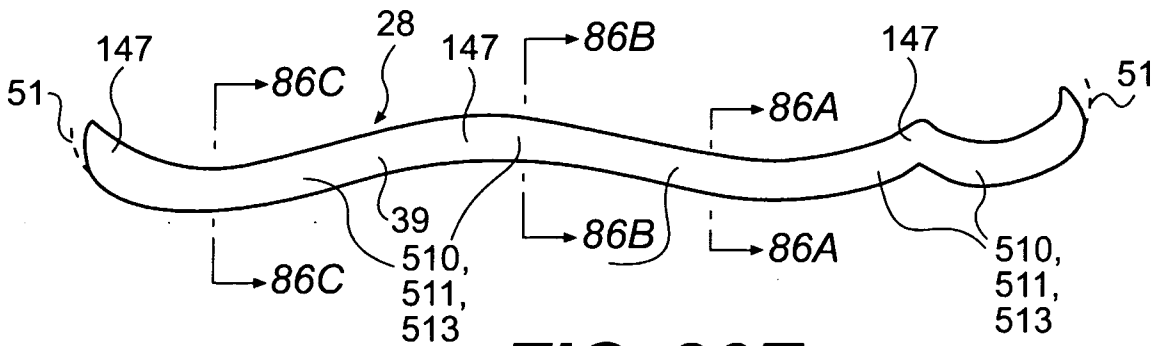

FIG. 86E

58/59

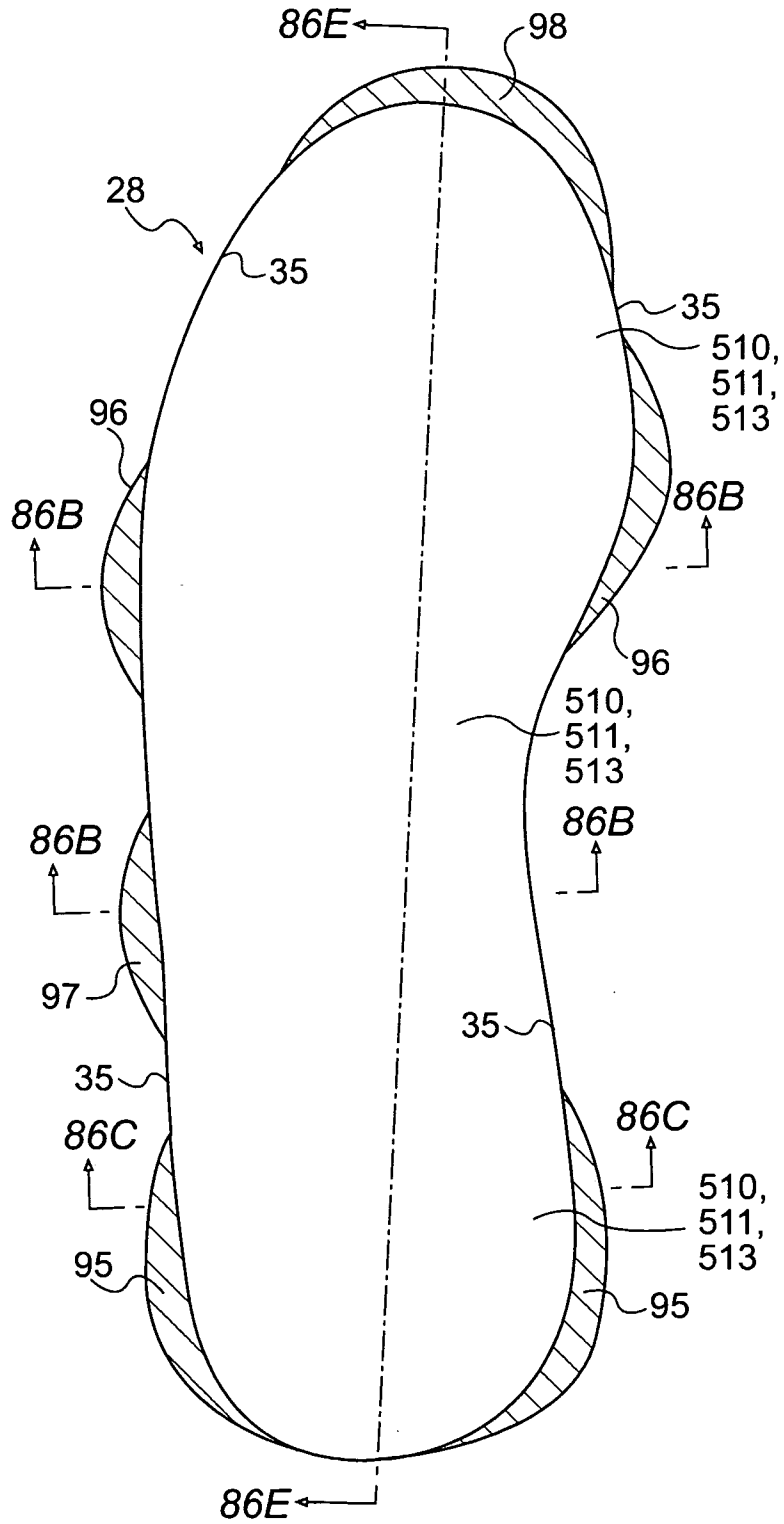

FIG. 86D

59/59

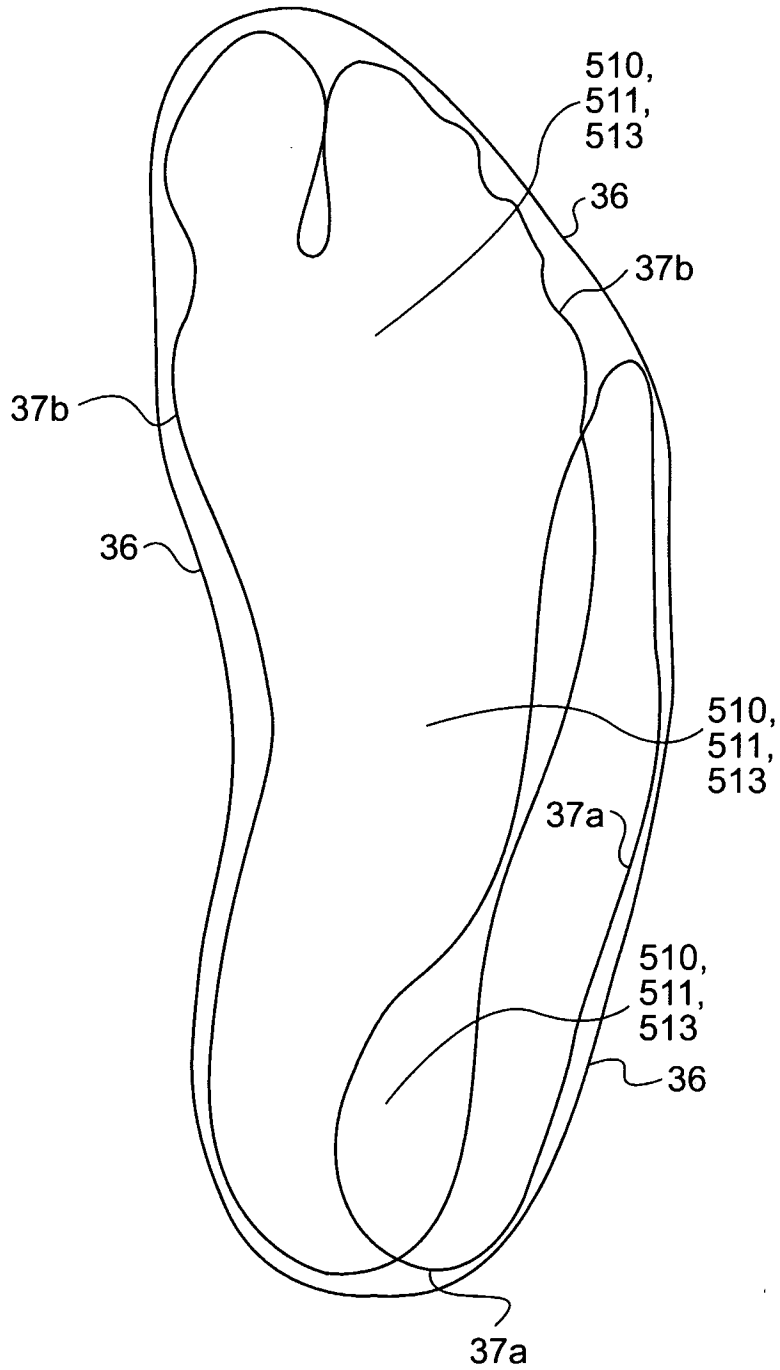

FIG. 87