



INTERNATIONAL APPLICATION PUBLISHED UNDER THE PATENT COOPERATION TREATY (PCT)

<p>(51) International Patent Classification<sup>3</sup>: G01F 11/28, 11/40; B01J 4/00</p>	<p>A1</p>	<p>(11) International Publication Number: WO 82/00349 (43) International Publication Date: 4 February 1982 (04.02.82)</p>
<p>(21) International Application Number: PCT/DK81/00073 (22) International Filing Date: 21 July 1981 (21.07.81) (31) Priority Application Number: 3162/80 (32) Priority Date: 22 July 1980 (22.07.80) (33) Priority Country: DK  (71) Applicant (for all designated States except US): ASKOV MEJERI A/S [DK/DK]; Nykøbingvej 21, DK-4440 Mørkøv (DK).  (72) Inventors; and (75) Inventors/Applicants (for US only): FREDSGAARD, Evald, Wenge [DK/DK]; Løvsangervej 11, DK-4300 Holbæk (DK). ERHALD, Fritz [DK/DK]; Mørkøv Kirkeby 28, DK-4440 Mørkøv (DK). HENRIKSEN, Jørgen [DK/LB]; Hourani Str., Chebaro Bldg., 3rd Floor, Beirut (LB).</p>	<p>(74) Agent: PLOUGMANN &amp; VINGTOFT; Vester Farimagsgade 3, DK-1606 Copenhagen V (DK).  (81) Designated States: AT (European patent), AU, BR, CH (European patent), DE (European patent), FI, FR (European patent), GB (European patent), JP, NL (European patent), NO, SE (European patent), US.  <b>Published</b> <i>With international search report Before the expiration of the time limit for amending the claims and to be republished in the event of the receipt of amendments</i></p>	

(54) Title: A METHOD AND AN APPARATUS FOR METERING A PULVERULENT OR PARTICULATE MATERIAL

## (57) Abstract

In a method and an apparatus for metering a pulverulent or particulate material one end of a flexible hose length (12) is communicating with a reservoir (10) for the said material, while the other end of the hose length is communicating with a tubing system (17, 19), in which an subatmospheric pressure is provided by means of a pump (18). The end portions of the hose length (12) may be compressed and tightly closed by means of pinch rollers (27) which may be reciprocated by means of pneumatic or hydraulic cylinders (26). When a metered amount of material has been discharged from the measuring chamber (30) defined by the hose length (12), the upper end portion of the hose length is pinched, while the lower end portion of the hose length is open, so that vacuum is present in the measuring chamber. The lower end portion of the hose length is now closed, and the upper end portion is opened, whereby an amount of material is sucked into the measuring chamber substantially without entrainment of air. The upper end portion of the hose length is now pinched, and thereafter the lower end portion of the hose length is opened, whereby an accurately metered amount of material is sucked into the tubing system (17, 19). This metering apparatus permits an accurate metering of pulverulent or particulate material substantially without entrainment of air.

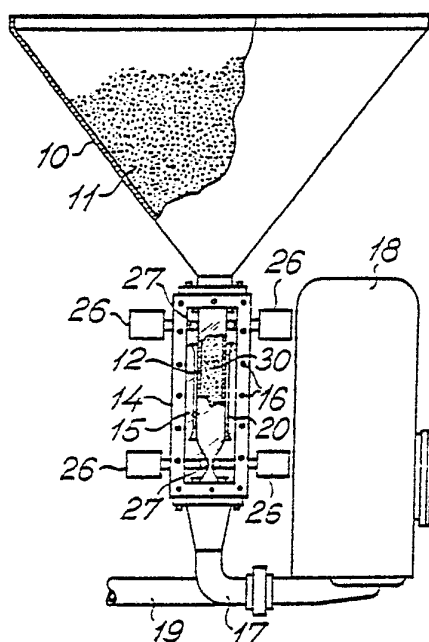

**FOR THE PURPOSES OF INFORMATION ONLY**

Codes used to identify States party to the PCT on the front pages of pamphlets publishing international applications under the PCT.

<b>AT</b>	Austria	<b>KP</b>	Democratic People's Republic of Korea
<b>AU</b>	Australia	<b>LI</b>	Liechtenstein
<b>BR</b>	Brazil	<b>LU</b>	Luxembourg
<b>CF</b>	Central African Republic	<b>MC</b>	Monaco
<b>CG</b>	Congo	<b>MG</b>	Madagascar
<b>CH</b>	Switzerland	<b>MW</b>	Malawi
<b>CM</b>	Cameroon	<b>NL</b>	Netherlands
<b>DE</b>	Germany, Federal Republic of	<b>NO</b>	Norway
<b>DK</b>	Denmark	<b>RO</b>	Romania
<b>FI</b>	Finland	<b>SE</b>	Sweden
<b>FR</b>	France	<b>SN</b>	Senegal
<b>GA</b>	Gabon	<b>SU</b>	Soviet Union
<b>GB</b>	United Kingdom	<b>TD</b>	Chad
<b>HU</b>	Hungary	<b>TG</b>	Togo
<b>JP</b>	Japan	<b>US</b>	United States of America

A METHOD AND AN APPARATUS FOR METERING A PULVERULENT  
OR PARTICULATE MATERIAL.

5 The present invention relates to a method of metering a  
pulverulent or particulate material.

10 In metering amounts of pulverulent or particulate material on the  
basis of the volume of the material it may be difficult to obtain  
metered amounts of material having substantially the same weight,  
because when metered in a measuring cup or chamber the material  
may accidentally contain greater or smaller air volumes. When the  
metered amount is to be used in a production or treating plant, it  
15 may also be disadvantageous if the metered amounts of material  
contain substantial volumes of air. As an example, this is true in  
connection with a plant as that disclosed in applicant's Danish  
patent application No. 3161/80, which was filed on 22nd July,  
1980, and which is hereby incorporated herein by reference. In a  
20 plant as that disclosed in the said patent application the  
introduction of substantial air volumes in the plant together with  
the metered amounts of pulverulent or particulate material would  
give rise to serious difficulties due to heavy generation of foam.

25 British patent specification No. 1,492,033 discloses a metering  
apparatus having a tubular measuring chamber with compressible  
inlet and outlet end portions, of which end portions the inlet end  
portion is communicating with a feeding hopper. The compressible  
inlet and outlet end portions are surrounded by chambers, and by  
30 supply of vacuum and pressurized air, respectively, to these  
chambers, the said end portions may alternately be opened and  
closed by compression in such a time sequence that the measuring  
chamber is alternately filled with the material to be metered  
through the inlet end portion, and emptied through the outlet end  
portion. The use of this known metering apparatus involves not  
35 only the above-mentioned problem that accidental volumes of air  
are entrained with the metered material, but also that it cannot be  
secured that the measuring chamber is completely filled and/or

emptied every time. Both of these problems may substantially influence the metering accuracy which may be obtained.

5 The present invention provides a metering method allowing an especially accurate metering and a substantially airless sluicing of the metered amounts of material into a container or treating plant, or another receiver.

10 The method according to the invention comprises the use of a measuring chamber having compressible inlet and outlet end portions communicating with an inlet and outlet space, respectively, each of said end portions being alternately closed by compression and opened in such a timed sequence that material is introduced into the measuring chamber, while the inlet end portion is open and the outlet end portion is closed, that a metered amount of material is thereafter enclosed within the measuring chamber by closing the inlet end portion, and that the metered amount of material is then discharged into the outlet space by opening the outlet end portion of the measuring chamber, and the method according to the invention is characterized in that a pressure substantially lower than the pressure within the inlet space, is generated in the outlet space as well as in one or more spaces or chambers surrounding the compressible wall parts of the measuring chamber.

25 Due to the pressure difference existing in the inlet space and outlet space, respectively, the particles of the material to be metered will be tightly packed together when the material is sucked or pressed into the measuring chamber, and because the inlet end portion of the measuring chamber is tightly closed when the outlet end portion is opened, the metered amount of material will be sluiced from the inlet space to the outlet space substantially free of air. The compressible inlet and outlet end portions of the measuring chamber permits an air-tight closing of the end portions of the measuring chamber in a simple manner without using complicated or vulnerable valve devices.

BAD ORIGINAL



In principle, it would be possible to supply pressurized air to the inlet space of the measuring chamber and to supply pressurized air at a lower pressure or air at atmospheric pressure to the outlet space and to the space or spaces surrounding the compressible wall parts of the measuring chamber. In practice, however, it is normally advantageous to generate a vacuum in the outlet space, while the inlet space is communicating with the atmosphere. Thereby the volume of air entrained by the metered amounts of material will be further reduced. Due to the fact that the pressure in the space or spaces surrounding the compressible wall parts of the measuring chamber is substantially at the same low level as the pressure in the outlet space, the compressible parts of the measuring chamber may be made from a highly flexible material, such as rubber or soft plastic, and in the preferred embodiment the measuring chamber is formed by a flexible tube or hose length of such a material. The heavy shaking movements imparted to the compressible parts of the measuring chamber during opening and closing, secure that all of the material is discharged from the measuring chamber when its outlet end portion is opened.

The invention also relates to a metering apparatus for carrying out the method described above, and the apparatus according to the invention is of the type comprising a measuring chamber having compressible inlet and outlet end portions communicating with inlet and outlet spaces, respectively, and means for compressing the inlet and outlet end portions, respectively, and the apparatus according to the invention is characterized in that means are provided adapted to generate within the outlet space a pressure which is substantially lower than the pressure within the inlet space, that the measuring chamber and the inlet and outlet end portions thereof are surrounded by an outer chamber, and that means are provided adapted to generate in this outer chamber a pressure which substantially corresponds to the pressure within the outlet space.

As explained above, by means of this metering apparatus it is possible to obtain an accurate metering of pulverulent or

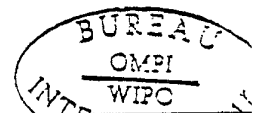
**BAD ORIGINAL**

particulate materials without entraining substantial volumes of air with the metered amounts of material.

5 The measuring chamber is advantageously formed by a flexible tube or hose length, which may be surrounded by a rigid tubular body extending between the end portions thereof, the inner diameter of said body being substantially equal to the outer diameter of the tube or hose length in its non-tensioned condition. As a suitably low pressure - for example, in the same order as the pressure within the outlet space - is maintained within the outer chamber surrounding the tube or hose length, this length will assume a shape determined by the inner surface of the rigid tubular body, even when the tube or hose length is made from a relatively soft material in order to facilitate compression of the end portions of said tube or hose length.

10

15

The invention will now be further described with reference to the drawings showing an embodiment of the metering apparatus according to the invention, and wherein

20 Fig. 1 is a side view and partially sectional view of a metering apparatus,

Fig. 2 is a side view and partially sectional view in an enlarged scale of part of the apparatus shown in Fig. 1, and

Fig. 3 is a side view and partially sectional view of a tube or hose length forming the measuring chamber in the apparatus shown in

25 Figs. 1 and 2.

The metering apparatus shown in the drawings is adapted to introduce metered amounts of pulverulent or particulate material into a production or treating plant, for example for introducing milk powder into a milk recombining plant as that described in applicant's Danish patent application No. 3161/80. The apparatus may, however, also be used for metering other kinds of pulverulent or particulate materials in cases where an accurate metering of amounts of material substantially free of air is desired.

30

35 The apparatus may also advantageously be used for metering liquid materials, especially when they are relatively viscous or paste-like.

**BAD ORIGINAL**

BUREAU  
OMPI  
WIPO

The apparatus shown in the drawings has an upwardly open material feeding hopper or a material reservoir 10 in which the material 11 to be metered is arranged. The lower outlet end of the hopper is tightly connected to the upper end of a flexible tube or hose length 12 having a sealing flange 13 at each end as shown in Fig. 3. The major part of the hose length 12 is surrounded by an outer vacuum chamber 14 having a front wall 15, which, as shown in Fig. 1, is removably fastened by means of a plurality of screws 16 or similar fastening members, and which is made from a transparent material, such as glass. The lower end of the hose length 12 is tightly connected to a tube bend 17, which is in turn communicating with the suction side of a self-priming pump 18, which is inserted in a tubing system 19 forming part of a treating or production plant to which it is desired to supply metered amounts of material without entrainment of air.

The center part of the hose length 12 is surrounded by a rigid tubular body 20 having an inner diameter which substantially corresponds to the outer diameter of the hose length in the non-tensioned condition thereof, and this body is fastened to the walls of the vacuum chamber by means of radially extending mounting members 21. Rigid tubular supporting bodies 23 corresponding to the body 20 is mounted in the opposite end walls 22 of the vacuum chamber 14, and the ends of the hose length 12 extend out from the vacuum chamber 14 through these supporting bodies as shown in Fig. 2.

Opposite side walls of the vacuum chamber 14 are provided with two pairs of aligned, internally threaded mounting sockets 25 for mounting pneumatic or hydraulic cylinders 26, preferably cylinders actuated by pressurized air. Each pair of cylinders 26 has oppositely directed piston rods each having a rotatably mounted pinch roller 27 arranged at their free ends. As indicated in Fig. 2, each pinch roller may comprise a shaft and a cylindrical shell of steel, such as stainless steel, and an intermediate layer of plastics material. Each pair of pinch rollers 27 may be moved towards and away from each other by means of the cylinders 26 between a first

~~NON ORIGINAL~~

BUREAU  
OMPI  
WIPO

position, which is indicated with dotted lines in Fig. 2, and in which the rollers are out of engagement with the hose length 12, and a second position, which is shown in solid lines in Fig. 2, and in which the rollers 27 are pinching and tightly close an inlet end portion 28 and an outlet end portion 29 of the hose length 12 positioned between the rigid body 20 and each of the rigid bodies 23. When both pairs of pinch rollers 27 are in the position shown with solid lines in Fig. 2, in which the hose length 12 is tightly pinched by the rollers, a measuring chamber 30 is defined within the hose length 12. During the reciprocating movements of the pinch rollers 27 their ends are guided by stationary guiding rails 31 mounted on the walls of the vacuum chamber 14.

The metering apparatus shown on the drawing operates as follows:

When the centrifugal pump 18 is operating it creates a substantial subatmospheric pressure at the suction side thereof, and when the outlet end portion 29 of the hose length 12 is not pinched this subatmospheric pressure will be transmitted to the measuring chamber 30 through the tube bend 17. The function of the cylinder 26 is controlled by means of a conventional control system, not shown, in such a manner that the pinch rollers 27 at any time close either the inlet end portion 28 or the outlet end portion 29 of the hose length 12, and some times both of these end portions. When a metered amount of material has just been discharged from the measuring chamber 30 thereby that the lower pair of pinch rollers 27 has been moved to the position indicated by dotted lines in Fig. 2, while the inlet end portion 28 of the hose length is still closed, vacuum will be present within the measuring chamber 30. An subatmospheric pressure or vacuum substantially corresponding to the vacuum generated in the measuring chamber 30 by the centrifugal pump 18, is provided in the outer vacuum chamber 14 by means of a vacuum pump, not shown, and thereby it is secured that the part of the hose length 12 defining the measuring chamber 30 assumes the extended position shown in the drawings, in which the outer surface of the hose length engages the inner surface of the rigid tubular body

BAD ORIGINAL





20, even when vacuum is present within the measuring chamber 30. The lower pair of pinch rollers 27 is now caused to close the outlet end portion 29 of the hose length, and immediately thereafter the upper pair of pinch rollers 27 is moved to their retracted position indicated by dotted lines so that the inlet end portion 28 is opened. As vacuum is present in the measuring chamber 30, while the upper surface of the material 11 arranged in the feeding hopper 10 is exposed to atmospheric pressure, the measuring chamber 30 will immediately be filled with material from the hopper 10 in a tightly packed condition substantially free of air. Thereafter, the inlet end portion 28 is closed by means of the upper pair of pinch rollers 27, and immediately thereafter the outlet end portion 29 of the hose length 12 is opened thereby that the lower pair of pinch rollers are moved back to their retracted position indicated by dotted lines in Fig. 2. The metered amount of material will then immediately be sucked out of the measuring chamber 30 and passed through the tube bend 17 into the tubing system 19. The sucking of the metered amount of material out from the measuring chamber 30 causes such a sudden transverse movement of the flexible walls of the chamber that possible sticky, for example moist, residues of the pulverulent or particulate material are released from the walls of the measuring chamber, whereby the metering apparatus will be self-cleaning. The operating cycle of the pinch rollers 27 just described may now be repeated a desired number of times and at a desired rate or frequency, whereby a desired number of accurately metered portions of material may be introduced into the tubing system 19 without entraining substantial amounts of air. This may i.a. be of importance if the tubing system 19 forms part of a plant, in which the existence of air might, for example, give rise to foaming or oxidation problems.

When the tubing system 19 forms part of a plant as that described in applicant's above-mentioned Danish patent application No. 3161/80, the capacity of the centrifugal pump 13 preferably substantially exceeds the capacity of the plant (for example 3 - 6 times), and the pump may, for example, be of the type marketed

ORIGINAL

BUREAU  
OMPI  
WIPO

by Pasilac A/S, Silkeborg, Denmark, under the designation "ZMS 3". In that case the pressure at the suction side of the pump, and consequently in the measuring chamber 30, may be about 0.4 atmosphere. It should be understood that the subatmospheric pressure or vacuum in the measuring chamber may be provided in any other suitable manner for other applications of the apparatus according to the invention, for example by means of a conventional vacuum pump. The hose length 12 may suitably be made from a plastic or rubber material having a suitable flexibility and such a strength and wearability that the hose length may resist the repeated mechanical stresses to which it is exposed by the pinch rollers 27. The hose length may, for example, be made from natural rubber of a quality marketed by Schønning & Arvé, Horsens, Denmark, under the quality designation "6344".

As mentioned above, the metering apparatus according to the invention may advantageously be used in connection with a plant for recombining milk or other liquid food products. It should be understood, however, that the metering apparatus according to the invention could also advantageously be used for other applications where an accurate metering of material substantially without entrainment of air is desired. In the embodiment described above the total measuring chamber is defined by the flexible hose length 12. However, the measuring chamber itself may, alternatively, have rigid walls provided that the inlet and outlet end portions 28 and 29 are of a material which may be closed by pinching. It should also be noted that the pinching means need not necessarily be in the form of rollers but could have any other form allowing a tight closing of the end portion of the measuring chamber. Furthermore, the pneumatic or hydraulic cylinders for actuating the pinching means could be replaced by other forms of actuating means, such as cams, eccentrics, or the like. The vacuum provided within the outer vacuum chamber 14 need not be the same as that provided at the outlet end portion 29 by the centrifugal pump 18. Thus, the pressure within the chamber 14 may be substantially lower than the subatmospheric pressure provided in the measuring chamber 30. However, in order to secure that the

BAD ORIGINAL



hose length 12 is always extended, the pressure provided within the outer chamber 14 should preferably not be substantially higher than the subatmospheric pressure provided at the suction side of the vacuum pump 18.

5

10

15

20

25

30

35

**BAD ORIGINAL**



## Claims.

5 1. A method of metering a pulverulent or particulate material (11)  
by means of a measuring chamber (30) having compressible inlet  
and outlet end portions (28, 29) communicating with inlet and  
outlet spaces (10, 17), respectively, each of said end portions  
10 being alternately closed by compression and opened in such a  
timed sequence that material is introduced into the measuring  
chamber, while the inlet end portion (28) is open and the outlet  
end portion (29) is closed, that a metered amount of material (11)  
is thereafter enclosed within the measuring chamber (30) by  
15 closing the inlet end portion (28), and that the metered amount of  
material is then discharged into the outlet space (17) by opening  
the outlet end portion (29) of the measuring chamber,  
c h a r a c t e r i z e d in that a pressure which is substantially  
lower than the pressure within the inlet space (10), is generated  
in the outlet space (17) as well as in one or more spaces or  
20 chambers (14) surrounding the compressible wall parts (12) of the  
measuring chamber.

2. A method according to claim 1,  
c h a r a c t e r i z e d in that vacuum is generated within the  
25 outlet space (17) and in the space or spaces (14) surrounding the  
compressible wall parts of the measuring chamber, while the inlet  
space (10) is maintained in communication with the atmosphere.

3. A metering apparatus for carrying the method according to  
30 claim 1 or 2 and comprising a measuring chamber (30) having  
compressible inlet and outlet end portions (28, 29) communicating  
with inlet and an outlet spaces (10, 17), respectively, and means  
(26, 27) for compressing the inlet and outlet end portions,  
respectively,  
35 c h a r a c t e r i z e d in that means (18) are provided adapted  
to generate within the outlet space (17) a pressure which is sub-  
stantially lower than the pressure within the inlet space (10), that

BAD ORIGINAL



the measuring chamber (30) and the inlet and outlet end portions (28, 29) thereof are surrounded by an outer chamber (14), and that means are provided adapted to generate in this outer chamber a pressure which substantially corresponds to the pressure within the outlet space (17).

4. A metering apparatus according to claim 3, characterized in that the total measuring chamber (30) is formed by a flexible tube or hose length (12).

5. A metering apparatus according to claim 4, characterized in a rigid tubular body (20) surrounding said tube or hose length (12) and extending between the end portions thereof, the inner diameter of said body being substantially equal to the outer diameter of the tube or hose length in its non-tensioned condition.

6. A metering apparatus according to any of the claims 3 to 5, characterized in that the inlet space (10) is communicating with the atmosphere, and that the outlet space (17) and the outer chamber (14) are communicating with a vacuum pump (13).

BAD ORIGINAL



Fig. 1.

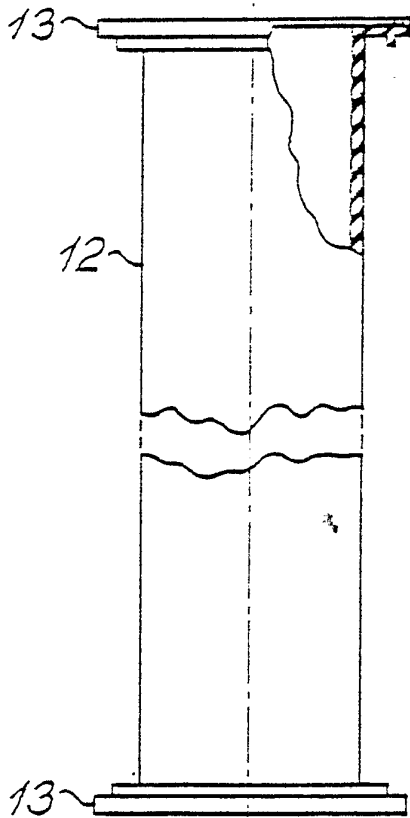
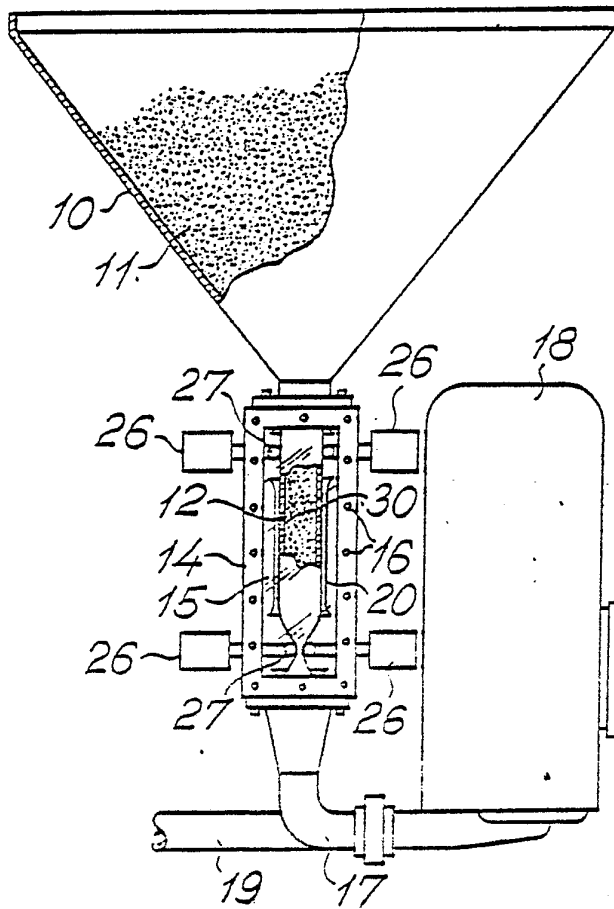

Fig. 2.

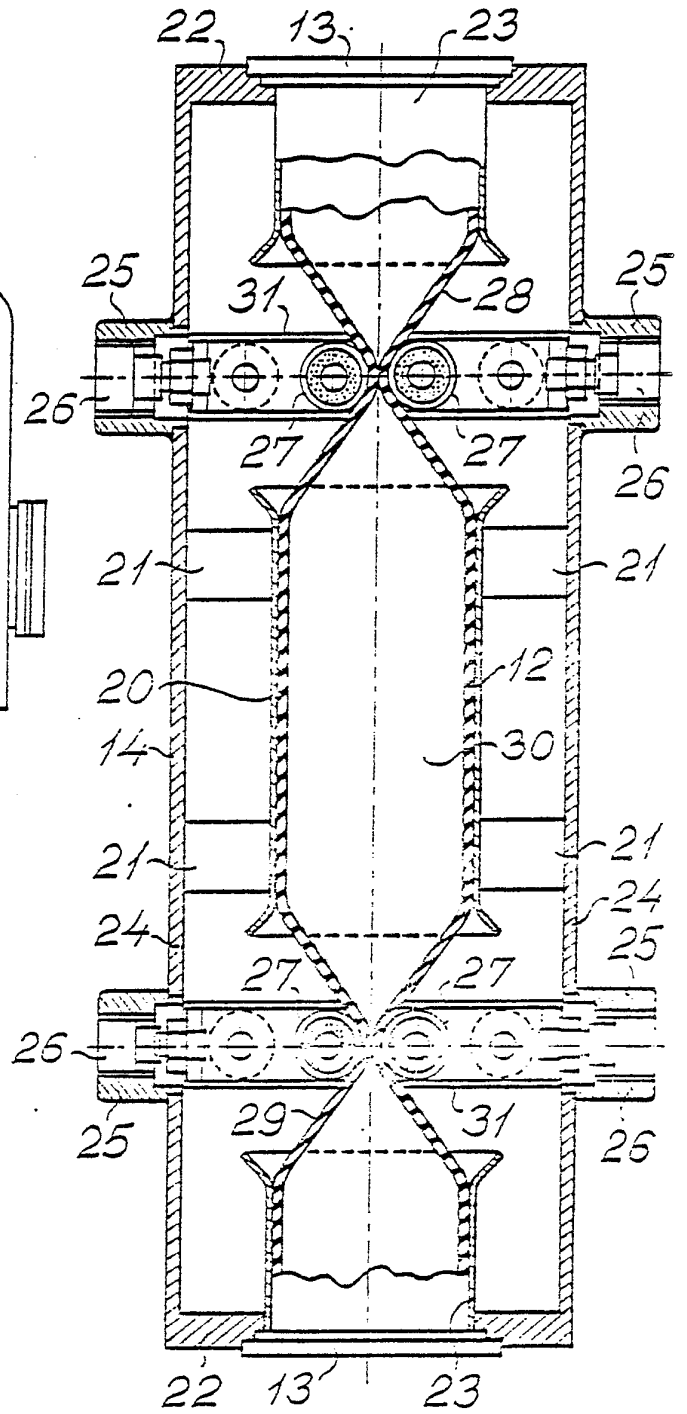

Fig. 3.

# INTERNATIONAL SEARCH REPORT

International Application No PCT/DK81/00073

<b>I. CLASSIFICATION OF SUBJECT MATTER</b> (if several classification symbols apply, indicate all) <sup>2</sup> According to International Patent Classification (IPC) or to both National Classification and IPC <b>3</b>  <div style="text-align: center; font-family: monospace; font-size: 1.2em;">G 01 F 11/28, 11/40, B 01 J 4/00</div>						
<b>II. FIELDS SEARCHED</b>  <div style="text-align: center;">Minimum Documentation Searched <sup>4</sup></div> <table border="1" style="width: 100%; border-collapse: collapse;"> <thead> <tr> <th style="width: 20%;">Classification System</th> <th style="width: 80%;">Classification Symbols</th> </tr> </thead> <tbody> <tr> <td style="text-align: center; vertical-align: top;">IPC <b>3</b></td> <td style="vertical-align: top;"> <div style="font-family: monospace; font-size: 1.1em;">                     B 01 J 4/00,4/02, B 65 B 1/00,1/16,1/30,1/36,                      B 65 G 65/40, G 01 F 11/00,11/28-11/46                 </div> <div style="text-align: right; font-size: 1.2em;">.../...</div> </td> </tr> </tbody> </table>			Classification System	Classification Symbols	IPC <b>3</b>	<div style="font-family: monospace; font-size: 1.1em;">                     B 01 J 4/00,4/02, B 65 B 1/00,1/16,1/30,1/36,                      B 65 G 65/40, G 01 F 11/00,11/28-11/46                 </div> <div style="text-align: right; font-size: 1.2em;">.../...</div>
Classification System	Classification Symbols					
IPC <b>3</b>	<div style="font-family: monospace; font-size: 1.1em;">                     B 01 J 4/00,4/02, B 65 B 1/00,1/16,1/30,1/36,                      B 65 G 65/40, G 01 F 11/00,11/28-11/46                 </div> <div style="text-align: right; font-size: 1.2em;">.../...</div>					
<div style="text-align: center; font-size: 0.8em;">Documentation Searched other than Minimum Documentation to the extent that such Documents are included in the Fields Searched <sup>6</sup></div>						
<div style="text-align: center; font-family: monospace; font-size: 1.1em;">SE, NO, DK, FI classes as above</div>						
<b>III. DOCUMENTS CONSIDERED TO BE RELEVANT</b> <sup>14</sup>						
Category <sup>8</sup>	Citation of Document, <sup>16</sup> with indication, where appropriate, of the relevant passages <sup>17</sup>	Relevant to Claim No. <sup>18</sup>				
A	FR, A, 1 519 607 published 1968, April 5, N Schlumberger & Cie	1, 3				
A	GB, A, 1 492 033 published 1977, November 16, United Kingdom Atomic Energy Authority	1, 3, 4				
A	US, A, 3 971 494 published 1976, July 27, Sidney Rosen	1, 3, 4				
<table style="width: 100%; font-size: 0.8em;"> <tr> <td style="width: 50%; vertical-align: top;"> <sup>9</sup> Special categories of cited documents: <sup>15</sup>                      "A" document defining the general state of the art which is not considered to be of particular relevance                      "E" earlier document but published on or after the international filing date                      "L" document which may throw doubts on priority claim(s) or which is cited to establish the publication date of another citation or other special reason (as specified)                      "O" document referring to an oral disclosure, use, exhibition or other means                      "P" document published prior to the international filing date but later than the priority date claimed                 </td> <td style="width: 50%; vertical-align: top;">                     "T" later document published after the international filing date or priority date and not in conflict with the application but cited to understand the principle or theory underlying the invention                      "X" document of particular relevance; the claimed invention cannot be considered novel or cannot be considered to involve an inventive step                      "Y" document of particular relevance; the claimed invention cannot be considered to involve an inventive step when the document is combined with one or more other such documents, such combination being obvious to a person skilled in the art.                      "Z" document member of the same patent family                 </td> </tr> </table>			<sup>9</sup> Special categories of cited documents: <sup>15</sup> "A" document defining the general state of the art which is not considered to be of particular relevance "E" earlier document but published on or after the international filing date "L" document which may throw doubts on priority claim(s) or which is cited to establish the publication date of another citation or other special reason (as specified) "O" document referring to an oral disclosure, use, exhibition or other means "P" document published prior to the international filing date but later than the priority date claimed	"T" later document published after the international filing date or priority date and not in conflict with the application but cited to understand the principle or theory underlying the invention "X" document of particular relevance; the claimed invention cannot be considered novel or cannot be considered to involve an inventive step "Y" document of particular relevance; the claimed invention cannot be considered to involve an inventive step when the document is combined with one or more other such documents, such combination being obvious to a person skilled in the art. "Z" document member of the same patent family		
<sup>9</sup> Special categories of cited documents: <sup>15</sup> "A" document defining the general state of the art which is not considered to be of particular relevance "E" earlier document but published on or after the international filing date "L" document which may throw doubts on priority claim(s) or which is cited to establish the publication date of another citation or other special reason (as specified) "O" document referring to an oral disclosure, use, exhibition or other means "P" document published prior to the international filing date but later than the priority date claimed	"T" later document published after the international filing date or priority date and not in conflict with the application but cited to understand the principle or theory underlying the invention "X" document of particular relevance; the claimed invention cannot be considered novel or cannot be considered to involve an inventive step "Y" document of particular relevance; the claimed invention cannot be considered to involve an inventive step when the document is combined with one or more other such documents, such combination being obvious to a person skilled in the art. "Z" document member of the same patent family					
<b>IV. CERTIFICATION</b>						
Date of the Actual Completion of the International Search <sup>2</sup>	Date of Mailing of this International Search Report <sup>1</sup>					
1981-11-18	1981-11-24					
International Searching Authority <sup>1</sup>	Signature of Authorized Officer <sup>10</sup>					
Swedish Patent Office	Harriet Ekdahl					

## FURTHER INFORMATION CONTINUED FROM THE SECOND SHEET

II Fields Searched (cont)

National Cl 42e:16, 27; 81a:5/01

US Cl 222/205-215, 450-453;  
251/4-10V.  OBSERVATIONS WHERE CERTAIN CLAIMS WERE FOUND UNSEARCHABLE <sup>10</sup>

This international search report has not been established in respect of certain claims under Article 17(2) (a) for the following reasons:

1.  Claim numbers ..... because they relate to subject matter <sup>12</sup> not required to be searched by this Authority, namely:
2.  Claim numbers ..... because they relate to parts of the international application that do not comply with the prescribed requirements to such an extent that no meaningful international search can be carried out <sup>13</sup>, specifically:

VI.  OBSERVATIONS WHERE UNITY OF INVENTION IS LACKING <sup>14</sup>

This International Searching Authority found multiple inventions in this international application as follows:

1.  As all required additional search fees were timely paid by the applicant, this international search report covers all searchable claims of the international application.
2.  As only some of the required additional search fees were timely paid by the applicant, this international search report covers only those claims of the international application for which fees were paid, specifically claims:
3.  No required additional search fees were timely paid by the applicant. Consequently, this international search report is restricted to the invention first mentioned in the claims; it is covered by claim numbers:
4.  As all searchable claims could be searched without effort justifying an additional fee, the International Searching Authority did not invite payment of any additional fee.

## Remark on Protest

- The additional search fees were accompanied by applicant's protest.
- No protest accompanied the payment of additional search fees.